

THE UNIVERSITY OF CHICAGO  
ORIENTAL INSTITUTE PUBLICATIONS

---

JOHN ALBERT WILSON  
AND  
THOMAS GEORGE ALLEN  
*Editors*

MEGIDDO TOMBS

THE UNIVERSITY OF CHICAGO PRESS  
CHICAGO, ILLINOIS

---

THE BAKER & TAYLOR COMPANY  
NEW YORK

THE CAMBRIDGE UNIVERSITY PRESS  
LONDON

THE MARUZEN-KABUSHIKI-KAISHA  
TOKYO, OSAKA, KYOTO, FUKUOKA, SENDAI

THE COMMERCIAL PRESS, LIMITED  
SHANGHAI



EW

LB I JUG FROM TOMB 1100 A (= PL. 46:16). SCALE, 3:4

7  
BS  
110  
M4  
ca

THE UNIVERSITY OF CHICAGO  
ORIENTAL INSTITUTE PUBLICATIONS  
VOLUME XXXIII

---

# MEGIDDO TOMBS

*By*

P. L. O. GUY

WITH CONTRIBUTIONS BY

ROBERT M. ENGBERG



THE UNIVERSITY OF CHICAGO PRESS  
CHICAGO, ILLINOIS

COPYRIGHT 1938 BY THE UNIVERSITY OF CHICAGO  
ALL RIGHTS RESERVED. PUBLISHED DECEMBER 1938

---

COMPOSED AND PRINTED BY THE UNIVERSITY OF CHICAGO PRESS  
CHICAGO, ILLINOIS, U.S.A.

## EDITORS' PREFACE

The nucleus of this volume is Mr. Guy's original manuscript, which comprised a study of the tombs excavated during his field directorship of the Megiddo Expedition. Earlier excavations, however, directed by Dr. Clarence S. Fisher, likewise brought to light numerous tombs. A true picture of the situation therefore involved combining with Mr. Guy's manuscript brief accounts of the tombs excavated by Dr. Fisher.<sup>1</sup> These, along with descriptions of objects found in the Fisher tombs, have been prepared by Dr. Engberg, formerly of the Megiddo Expedition staff, from Dr. Fisher's field records.<sup>2</sup> Mr. Guy's text has been further supplemented by a chapter by Dr. Engberg on the antiquities found in the tombs (chap. iv). The drawings illustrating the Fisher tomb finds as well as those in Figures 169-86 are the work of Mr. A. R. Hauser. Mr. W. W. Romig also assisted in preparing those figures. Supervision of the preparation of the volume for the press has been primarily in the hands of Mrs. Hauser of the editorial office.

In Mr. Guy's original manuscript the tombs were treated in numerical order, but the editors found it advisable to arrange them chronologically as far as possible. An index carries them in numerical order (p. 215). In cases where more than one period is represented the entire tomb is discussed under the first period which produced a quantity of remains.

Mr. Guy's terminology for the various periods involved has been modified to some extent on the basis of evidence from later excavations at Megiddo. On the same basis his dating of some of the objects has been changed.

In Dr. Fisher's field records the prefix x was added to the field numbers to denote objects not found *in situ* on a floor.<sup>3</sup> In order to keep his distinction clear we have added x's to the final registration numbers where applicable. For objects which were not registered we have retained the field numbers which Dr. Fisher used.

Dr. Engberg would here express his gratitude to Professor A. T. Olmstead and Drs. G. G. Cameron, N. C. Debevoise, and I. J. Gelb for criticism and suggestions bearing on chapter iv and to Miss Ann L. Perkins, a student at the Oriental Institute, for classifying the beads. Other acknowledgments are made in the text.

<sup>1</sup> The tomb numbers concerned are those between 1 and 60.

<sup>2</sup> The Fisher material has been treated as far as possible in accordance with the principles discussed by Mr. Guy in chap. i.

<sup>3</sup> *OIC* No. 4, p. 9.

## PREFACE

There are two series of plates illustrating the contents of the tombs. On Plates 3-75 are given drawings of most of the pottery vessels found. The drawings are all reproduced at a scale of 1:5. Much of the pottery is shown in photograph also, along with illustrations of other types of objects, on Plates 76-176. On these plates normally the pottery vessels are shown at 1:5 and other objects at actual size. Some pots are shown only in photograph because drawings were considered superfluous. Each series of plates is arranged by tombs in the order in which the tombs are discussed in the text. All objects shown on each plate are described, and dated where possible, on the page opposite the plate. To complete the picture of each tomb group there have been listed with these descriptions the few objects which it was thought unnecessary to illustrate because they are duplicated in the volume. Complete cross-references have been supplied.

During the excavation of the tombs and the preparation of the present volume the staff of the Megiddo Expedition included the following members:

Clarence S. Fisher, field director, September 1925—May 1927; advisory director, May 1927—June 1929

Daniel F. Higgins, assistant field director, August 1925—June 1926

Edward L. DeLoach, surveyor, September 1925—March 1930

Stanley Fisher, accountant, September 1925—November 1926

William Effendi Gad, assistant surveyor, September 1925—May 1927

Labib Effendi Sorial, assistant surveyor, September 1925—May 1927

Olaf E. Lind, photographer, August 1926—August 1936

Miss Ruby Woodley, recorder, August 1926—August 1928

Hassan Effendi Hassan, draftsman, April—October 1927

John A. Wilson, volunteer, April—June 1927

P. L. O. Guy, field director, May 1927—June 1935

Ralph B. Parker, superintendent, June 1927—

Geoffrey M. Shipton, draftsman and assistant recorder, March 1928—

Charles Little, draftsman, April—July 1928

Emanuel Wilensky, surveyor, April—June 1928; archeological assistant, April 1932—June 1933

J. Terentieff, surveyor, June—September 1928

William E. Staples, epigrapher and recorder, September 1928—July 1931

Robert S. Lamon, surveyor and field assistant, September 1928—December 1936

Charles Kent, draftsman, March—June 1929

R. W. Hamilton, volunteer, June—July 1929

Laurence C. Woolman, architect, September 1929—June 1930

Dudley W. Phillips, archeological assistant, October 1930—January 1931

Robert M. Engberg, topographical assistant, October 1930—June 1934

C. M. Hucklesby, surveyor, June—July 1931

Herbert G. May, epigrapher and recorder, October 1931—June 1934

James H. Breasted, Jr., volunteer, September—October 1932

Arthur C. Piepkorn, volunteer, May—July 1933

Ernest F. Beaumont, surveyor, June—October 1933

T. A. L. Concannon, architect and surveyor, September 1933—June 1934

A general survey of the site was made in 1925/26 by the late Mr. Higgins, assisted by DeLoach, and a plan (Fig. 2) was drawn by the latter. DeLoach helped with the excavation of the tombs dug in 1927/28 and also planned most of them, while Lamon became an expert tomb-digger during the seasons 1930-32. He planned the tombs found during those seasons

and redrew the plans of all the tombs on scales suitable to the format of the present volume. Engberg and Shipton also dug some tombs during 1930-32 and tackled the large ossuary T. 903 Upper (see p. 9). Where skeletal remains were found it was generally Engberg who was given the task of removing them and doing such conservation work as could be done in the field. In this he was helped by Shipton.

The recording of objects was successively the charge of Miss Woodley, Staples, and May, with Shipton helping throughout. Most of the original record drawings were Shipton's work, as are the majority of the pottery drawings in the present publication, the rest being mainly due to Engberg. The painting for the frontispiece was done by Wilensky. It was chiefly May who from the original records put into their present standardized form the descriptions of the objects which appear on the plates. The plates themselves were made up by combined effort mainly on the part of Shipton, May, and Engberg.

The photography has throughout been in the able hands of Lind. And Parker by looking after everything which was not archeological—pay, accounts, commissariat, transport, building maintenance, and the like—enabled the other members of the staff to carry on their work without interruption and in comfort.

The rais Hamid Ahmed Hamid has always been a most efficient, trustworthy, and faithful foreman, and his little group of skilled Egyptians formed an excellent nucleus to our gang of local workmen as well as providing us with our specialists—Ali el-Kosseiri and Mahmoud, the pot-menders; Abu Yusef, rodman and ever willing jack-of-all-trades; and Salameh, Lind's assistant. Serge Tchoub, our chauffeur, has done much more than drive our trucks (even this was not always an easy task before the present good road was made to Haifa), and his wife has been as useful in the house as he has been outside.

Through the period during which I was at Megiddo my colleagues and I became pleasantly indebted to many archeologists who visited the excavations. Our gratitude, and particularly my personal gratitude, to Père Vincent can never be adequately expressed. Sir Flinders Petrie's wide knowledge of Near Eastern archeology has always been most readily placed at our disposal, and his unfailing courtesy to men much younger than himself has endeared him to us all. To my old friend and master, Sir Leonard Woolley, of Ur, I owe more than I can say.

It is very good to look back and remember the many stimulating talks and discussions, the comparisons of pottery, the arguments over dating and origins, and the general exchanges of views which we have had with such friends as W. F. Albright, the late Edward Chiera, Mr. and Mrs. J. W. Crowfoot, Maurice Dunand, G. M. FitzGerald, Henri Frankfort, Miss Dorothy Garrod (who has been particularly kind in the matter of flints), Nelson Glueck, George Horsfield and his wife, Ernest Mackay, the late Père Mallon, Harold H. Nelson, J. D. S. Pendlebury, W. J. Phythian-Adams, the late Claude Prost, Hermann Ranke, Alan Rowe, C. F. A. Schaeffer, the late J. L. Starkey, Sir Aurel Stein, E. L. Sukenik, and S. Yeivin.

Officials of the United States Consulate-General in Jerusalem have been not merely official in their relations with the expedition and its members. We owe much to the Palestine Government. Each of the successive High Commissioners has visited the excavations and shown a personal interest in them, while officials of the Secretariat, the District Authority and the Police, and of the departments of Customs, Health, Immigration, Lands, Law, Posts and Telegraphs, Public Works and Railways have, each in his own sphere, done all they could to make things easy for us. The Director of Antiquities and his staff have been most helpful at all times.

Dr. Hoffman, of the German Hospital in Haifa, has not only looked after the health of both the occidental and the oriental members of the expedition but is the friend of all of us.

The tombs yielded a large body of human skeletal material, much of it from the earliest periods, and work on the tell has produced numerous Iron Age skeletons. All of these were removed and preserved. For their study by laboratory methods Dr. Breasted obtained the co-operation of Dr. Aleš Hrdlička, curator of the Division of Physical Anthropology of the United States National Museum. Unfortunately the bones were considerably damaged during their journey to America, so that many of them were useless for Dr. Hrdlička's report (chap. v).<sup>1</sup>

Miss Dorothea M. A. Bate, of the Department of Geology of the British Museum, kindly prepared a report on the animal remains (chap. vi).

To Dr. T. George Allen is due credit for the scarab descriptions given in connection with the plates on which scarabs are illustrated.

P. L. O. GUY

<sup>1</sup> All of the skeletal remains studied by Dr. Hrdlička are now in the United States National Museum.



## TABLE OF CONTENTS

	PAGE
LIST OF ILLUSTRATIONS . . . . .	xv
LIST OF ABBREVIATIONS . . . . .	xxiii
I. INTRODUCTION . . . . .	1
The Site . . . . .	1
Recording and Numbering . . . . .	2
Accuracy of the Records . . . . .	4
Survey and Plans . . . . .	4
Drawings of Antiquities . . . . .	4
Measurements . . . . .	5
Terminology . . . . .	5
General . . . . .	5
Pottery . . . . .	5
Other objects . . . . .	6
Archeological Classification and Dating . . . . .	7
II. TOMB DESCRIPTIONS . . . . .	9
III. BURIAL CUSTOMS . . . . .	135
Chalcolithic and Early Bronze (Stages I-VII) . . . . .	135
Early Bronze (Stage 0-I) . . . . .	135
Middle Bronze I . . . . .	135
Middle Bronze II . . . . .	137
Late Bronze I . . . . .	137
Late Bronze II . . . . .	138
Iron Age . . . . .	138
Roman Period . . . . .	138
IV. SOME CHARACTERISTICS OF THE SUCCESSIVE PERIODS. <i>Robert M. Engberg</i> . . . . .	143
Pottery Vessels . . . . .	143
Chalcolithic . . . . .	143
Early Bronze . . . . .	146
Middle Bronze I . . . . .	148
Middle Bronze II . . . . .	150
Late Bronze I . . . . .	151
Late Bronze II . . . . .	154
Early Iron I . . . . .	159
Copper and Bronze . . . . .	160
Iron . . . . .	162
Tools and Weapons . . . . .	163
Spearheads . . . . .	163
Daggers . . . . .	164
Knives . . . . .	165
Axheads and Other Blades . . . . .	167
Toggle Pins . . . . .	168
Flint Implements . . . . .	170
Other Stone Implements . . . . .	170
Whorls and Spindles . . . . .	170
Personal Ornaments . . . . .	173
Finger Rings . . . . .	173
Earrings . . . . .	177

## TABLE OF CONTENTS

	PAGE
Bracelets . . . . .	177
Amulets and Pendants . . . . .	177
Beads . . . . .	179
Cylinder Seals . . . . .	182
Scarabs and Scaraboids . . . . .	184
Inlays . . . . .	186
Vessels Other than Pottery . . . . .	186
Stone . . . . .	186
Fayence . . . . .	188
Ivory . . . . .	188
"Bronze" . . . . .	188
Glass . . . . .	189
V. SKELETAL REMAINS. <i>Aleš Hrdlička</i> . . . . .	192
VI. ANIMAL REMAINS. <i>Dorothea M. A. Bate</i> . . . . .	209
INDEX OF TOMBS . . . . .	215
INDEX OF SKELETON NUMBERS . . . . .	217
GENERAL INDEX . . . . .	219

## LIST OF ILLUSTRATIONS

*Frontispiece (in colors)*. LB I jug from Tomb 1100 A

### PLATES

1. GENERALIZED PLAN OF PART OF THE EAST SLOPE
2. BALLOON PHOTOGRAPH OF THE AREA ON THE EAST SLOPE EXCAVATED IN 1931/32, LOOKING EAST
3. HANDMADE CHALCOLITHIC (EXCEPT No. 50) POTTERY FROM TOMB 903
4. HANDMADE (UNLESS OTHERWISE STATED) POTTERY FROM TOMB 910
5. POTTERY FROM TOMBS 1122 AND 1128
6. POTTERY FROM TOMBS 52, 1106, AND 1101
7. EB (STAGE 0-I) POTTERY FROM TOMBS 1101-2
8. EI I POTTERY FROM TOMB 1101
9. EI I POTTERY BOWLS FROM TOMBS 1101-2
10. POTTERY FROM TOMBS 9, 41, 67 A, AND 217 B
11. LB POTTERY FROM TOMB 217 C AND MB I POTTERY FROM TOMB 877 A 2
12. MB I AND LB II POTTERY FROM TOMB 877
13. LB II POTTERY FROM TOMB 877
14. LB POTTERY FROM TOMB 877
15. MB I AND LB II POTTERY FROM TOMB 989
- 16-17. LB POTTERY FROM TOMB 989 A 1
18. LB II POTTERY JARS FROM TOMB 989
19. LB POTTERY FROM TOMB 989
20. LB POTTERY FROM TOMB 989 AND MB I POTTERY FROM TOMBS 878, 880 A, AND 884 A
21. MB I AND LB I POTTERY FROM TOMBS 884, 1098, AND 891 A
22. MB I POTTERY FROM TOMBS 922 A, 1014, AND 1120
23. MB II POTTERY FROM TOMB 24
24. MB II POTTERY FROM TOMBS 42-44
25. MB II POTTERY FROM TOMBS 45, 49, AND 233
26. MB II POTTERY FROM TOMBS 233-34, 247, AND 251
27. MB II (EXCEPT PERHAPS No. 6) POTTERY FROM TOMBS 253-54, 257-58, 644-45, AND 868
- 28-29. MB II POTTERY FROM TOMB 911 A 1
30. LB II POTTERY FROM TOMB 911 A 1
31. MB AND LB II POTTERY FROM TOMB 911
32. MB II POTTERY FROM TOMB 911 D AND LB II POTTERY FROM TOMB 912
33. MB AND LB II POTTERY FROM TOMB 912 A
34. LB II POTTERY FROM TOMB 912 B
35. MB II AND LB II POTTERY FROM TOMB 912
36. LB II POTTERY BOWLS FROM TOMB 912 D
37. LB POTTERY FROM TOMB 3
38. LB I AND MI POTTERY FROM TOMBS 18, 20-21, AND 37
39. LB AND IRON AGE POTTERY FROM TOMB 37
40. LB I AND IRON AGE POTTERY FROM TOMBS 37-38
41. LB I POTTERY FROM TOMBS 38, 75, AND 77
42. POTTERY FROM TOMBS 77-78 AND 219
43. MI POTTERY FROM TOMB 219 AND LB I POTTERY FROM TOMB 855
44. LB I POTTERY FROM TOMBS 855-56 AND 976
45. LB I POTTERY FROM TOMBS 921 AND 1100 A
46. LB I POTTERY JUGS FROM TOMB 1100 A
- 47-48. LB I POTTERY FROM TOMB 1100
49. POTTERY FROM TOMBS 1141 AND 1145 A
- 50-52. LB I POTTERY FROM TOMB 1145

53. LB I POTTERY FROM TOMB 1178
- 54-55. LB POTTERY FROM TOMB 4
56. LB II POTTERY (No. 5 MB II) FROM TOMBS 4 AND 8
57. LB II POTTERY FROM TOMBS 25-26
58. LB POTTERY FROM TOMB 26
59. LB POTTERY FROM TOMBS 26 B, 36 B, 40, AND 48
60. POTTERY FROM TOMBS 48 AND 63
61. POTTERY FROM TOMB 63
62. LB II AND IRON AGE POTTERY FROM TOMB 63
63. POTTERY FROM TOMB 63
64. LB AND IRON AGE POTTERY BOWLS FROM TOMB 73
65. POTTERY FROM TOMB 73
66. LB AND IRON AGE POTTERY FROM TOMB 73
67. LB II POTTERY FROM TOMB 1250
68. EI I POTTERY FROM TOMBS 17, 29, AND 39
69. EI I POTTERY FROM TOMBS 39 AND 62
70. EI I POTTERY (No. 6 MI) FROM TOMBS 62, 71-72, AND 221
71. EI I POTTERY FROM TOMB 221 B
72. EI I POTTERY (Nos. 8-9 EI II) FROM TOMBS 221 B AND 237
73. EI I POTTERY FROM TOMB 1090
74. IRON AGE POTTERY FROM TOMBS 27, 64, 47, AND 76
75. POTTERY FROM TOMB 80
76. CHALCOLITHIC OBJECTS FROM TOMB 903
77. CHALCOLITHIC JAR SHERDS (No. 12 BOWL SHERD) FROM TOMB 903 LOWER
78. CHALCOLITHIC POTSHERDS FROM TOMB 903 LOWER, ALL HANDMADE
- 79-80. CHALCOLITHIC (STAGES V-VII) FLINT IMPLEMENTS FROM TOMB 903 LOWER
81. POTSHERDS FROM TOMB 910, HANDMADE UNLESS OTHERWISE STATED
82. POTSHERDS FROM TOMB 910, ALL HANDMADE
83. OBJECTS FROM TOMBS 910, 1103, AND 1122 SHELF
84. OBJECTS FROM TOMBS 1122 UPPER AND 1128
85. OBJECTS FROM TOMBS 52 AND 1101-2
86. EB (STAGE 0-I) OBJECTS FROM TOMB 1101 B LOWER
87. EI I OBJECTS FROM TOMBS 1101-2
88. MB I OBJECTS (Nos. 8-9 AND 14 UNDATED) FROM TOMBS 41, 58, AND 67 A
89. OBJECTS FROM TOMB 217 A
90. UNDATED OBJECTS FROM TOMB 217 A AND MB I POTTERY FROM TOMB 217 B
91. LB POTTERY FROM TOMB 217 C AND MB I POTTERY FROM TOMB 877 A 2
92. MB I POTTERY FROM TOMB 877 A 2
93. MB I AND LB II POTTERY OBJECTS FROM TOMB 877
94. LB II OBJECTS FROM TOMB 877
95. LB II OBJECTS (No. 30 LB II OR HYKSOS) FROM TOMB 877 B 1
96. LB OBJECTS FROM TOMB 877
97. MB I AND LB II POTTERY FROM TOMB 989
- 98-100. LB OBJECTS FROM TOMB 989
101. LB II OBJECTS FROM TOMB 989 D 1 AND MB I OBJECTS FROM TOMBS 878, 884 A, AND 1098
102. MB I OBJECTS FROM TOMBS 891 A, 922 A, 1014, AND 1120
103. MB II OBJECTS FROM TOMB 24
104. MB II IVORY BOX IN THE FORM OF A DUCK, FROM TOMB 24
105. HYKSOS (MB II) SCARABS OF STEATITE FROM TOMB 24
106. HYKSOS (MB II) SCARABS OF STEATITE (No. 12 GREEN JASPER) FROM TOMB 24
107. OBJECTS FROM TOMBS 24 B AND 42
- 108-9. MB II BONE INLAYS FROM TOMB 42
110. MB II OBJECTS FROM TOMBS 43-44
111. MB II BONE INLAYS FROM TOMB 45
112. MB II OBJECTS (Nos. 12-14 MB II OR LB II) FROM TOMBS 45 AND 49-51

113. MB II OBJECTS FROM TOMB 51
114. OBJECTS FROM TOMBS 53, 56, AND 233-34
115. MB II OBJECTS FROM TOMBS 251, 253-54, AND 258
116. MB II OBJECTS FROM TOMBS 258, 644-45, AND 911 A I AND MB I POTTERY FROM TOMB 911 A 2
117. MB II AND LB II POTTERY FROM TOMB 911 A 1
118. MB II OBJECTS FROM TOMB 911 A 1
119. OBJECTS FROM TOMB 911
120. MB II AND LB II OBJECTS FROM TOMB 911 C
- 121-22. MB II OBJECTS FROM TOMB 911 D
123. MB I OBJECTS FROM TOMB 912 A 2 AND LB II OBJECTS FROM TOMB 912 A 1
124. MB II AND LB II VESSELS FROM TOMB 912 B
125. MB II AND LB II "BRONZE" OBJECTS FROM TOMB 912 B
126. "BRONZE" OBJECTS FROM TOMB 912 B
127. MB II OR LB II "BRONZE" OBJECTS FROM TOMB 912 B
128. OBJECTS FROM TOMB 912 B
129. MB II OR LB II WEIGHTS FROM TOMB 912 B
- 130-32. OBJECTS FROM TOMB 912 B
133. MB II AND LB II OBJECTS FROM TOMB 912 D
134. THE MEGIDDO VASE, FROM TOMB 912 D
135. OBJECTS FROM TOMBS 3, 6, 18, AND 20
- 136-38. OBJECTS FROM TOMB 37
139. OBJECTS FROM TOMBS 37-38
140. LB I OBJECTS FROM TOMBS 38 B, 75, AND 77
141. OBJECTS FROM TOMBS 78, 219, 855
142. LB I OBJECTS FROM TOMBS 855-56 AND 876
- 143-44. LB I POTTERY FROM TOMB 1100 A
- 145-48. LB I OBJECTS FROM TOMB 1100
149. LB I WEAPONS FROM TOMB 1100 D
150. LB I OBJECTS FROM TOMBS 1141 AND 1145 A
151. LB I POTTERY FROM TOMB 1145 B
152. LB I OBJECTS FROM TOMB 1145 B AND 1178
153. OBJECTS FROM TOMBS 1-2, 4, AND 8
154. OBJECTS FROM TOMBS 13 AND 26
155. OBJECTS FROM TOMB 26
156. OBJECTS FROM TOMBS 31, 36, 40, AND 48
157. OBJECTS FROM TOMB 59
158. OBJECTS FROM TOMB 63
159. LB II AND IRON AGE POTTERY FROM TOMB 73
160. POTTERY FROM TOMB 73
- 161-62. UNDATED OBJECTS FROM TOMB 73
163. OBJECTS FROM TOMBS 73 AND 84
164. EI I OBJECTS (NO. 4 EI I OR LB II) FROM TOMBS 11, 14, AND 39
165. EI I OBJECTS (NO. 2 HYKSOS) FROM TOMB 39
166. EI I OBJECTS FROM TOMB 39
167. EI I OBJECTS (NO. 7 HYKSOS) FROM TOMB 39
168. EI I OBJECTS FROM TOMBS 39 AND 62
169. EI I OBJECTS (NO. 5 MI) FROM TOMBS 71 AND 221
170. EI I OBJECTS FROM TOMBS 221 B, 237, AND 1090
171. OBJECTS FROM TOMBS 27, 64, 5, AND 47
172. OBJECTS FROM TOMBS 47 AND 76 A
173. OBJECTS FROM TOMBS 76 AND 80
174. OBJECTS FROM TOMB 80
175. OBJECTS FROM TOMBS 80 C, 19, 232, AND 950
176. OBJECTS FROM THE EAST SLOPE WHICH COULD NOT BE ASSIGNED TO TOMBS

## TABLES

	PAGE
I. CHRONOLOGICAL INDEX OF TOMBS AND BURIALS . . . . .	139-42
II. ANALYSES OF COPPER AND BRONZE OBJECTS . . . . .	161
III. ALPHABETIC SIGNS ON A RING FROM MEGIDDO AND RELATED SINAITIC, OLD CANAANITE, AND PHOENICIAN CHARACTERS . . . . .	175
IV. TYPES OF WELL DATED BEADS . . . . .	181
V. IMPORTANT FEATURES OF PERIODS REPRESENTED IN THE TOMBS . . . . .	190-91
VI. MEASUREMENTS AND INDICES OF MEGIDDO CRANIA . . . . .	<i>facing</i> 192

## TEXT FIGURES

1. MEGIDDO AND THE PLAIN OF ESDRAELON, LOOKING NORTH-NORTHEAST FROM THE NORTHEAST END OF WADI cARAH, WITH THE VILLAGE OF LEJJUN IN THE FOREGROUND AND THE HILLS OF NAZARETH IN THE BACKGROUND . . . . .	1
2. KEY PLAN OF MEGIDDO, SHOWING AREAS EXCAVATED ON THE EAST SLOPE . . . . .	3
3. TOMB 903 AFTER EXCAVATION, LOOKING NORTH . . . . .	10
4. TOMB 903 UPPER FROM WEST, SHOWING FIRST LAYER OF BONES . . . . .	10
5. TOMB 903 UPPER FROM EAST, SHOWING SECOND LAYER OF BONES . . . . .	11
6. TOMB 903 UPPER FROM EAST, SHOWING THIRD LAYER OF BONES . . . . .	11
7. SHERDS BEARING POTTERY MARKS, FROM TOMB 903 LOWER . . . . .	12
8. TOMB 903 FROM WEST, SHOWING TOMBS 1126-27 AND THE SKELETON OF A COW . . . . .	13
9. TOMB 1127, WITH SKELETON H 87 <i>in situ</i> . . . . .	13
10. TOMB 1126, WITH SKELETON H 88 <i>in situ</i> . . . . .	14
11. ENTRANCE TO TOMB 910 . . . . .	14
12. TOMB 910, LOOKING NORTHWEST FROM CHAMBER A . . . . .	15
13. TOMB 910, SHOWING SKELETAL REMAINS IN NORTH CORNER OF CHAMBER A . . . . .	15
14. PLAN AND SECTIONS OF TOMB 910 . . . . .	16
15. TOMB 910, LOOKING SOUTH FROM CHAMBER A INTO TOMB 912 . . . . .	17
16. TOMB 1103 FROM EAST, WITH PART OF SKELETAL REMAINS EXPOSED . . . . .	19
17. TOMB 1122 FROM NORTH, WITH LB II POTTERY . . . . .	19
18. TOMB 1128, LOOKING SOUTH FROM TOMB 1102, SHOWING SKELETAL REMAINS AND POTTERY . . . . .	21
19. TOMB 1106 FROM SOUTHWEST, SHOWING SKELETAL REMAINS AND WALL ACROSS FRONT OF CAVE . . . . .	21
20. BOWLS OF GRAY BURNISHED WARE AS FOUND IN POT-HOLE IN TOMB 1106 . . . . .	22
21. BASALT VESSEL FROM TOMB 1106 . . . . .	22
22. PLAN AND SECTIONS OF TOMBS 1101-2, 1106, AND 1128 . . . . .	23
23. TOMB 1101 A, LOOKING SOUTHWEST INTO CHAMBER B, SHOWING EI I OBJECTS . . . . .	24
24. TOMB 1101, SHOWING STRATIFICATION AND EI I POTTERY IN WEST CORNER OF CHAMBER B . . . . .	25
25. TOMB 1102 FROM NORTH-NORTHEAST, SHOWING EI I POTTERY . . . . .	26
26. TOMB 1101 B LOWER, LOOKING SOUTHEAST INTO TOMB 1102 . . . . .	27
27. PLAN AND SECTION OF TOMB 41 . . . . .	28
28. PLAN AND SECTION OF TOMB 58 . . . . .	30
29. TOMBS 66-67 AND 70 FROM SOUTHEAST, SHOWING TRACES OF THE QUARRYING WHICH DAMAGED THEM . . . . .	31
30. PLAN AND SECTION OF TOMB 217 . . . . .	32
31. TOMB 217 FROM EAST, SHOWING EFFECTS OF QUARRYING . . . . .	33
32. PLAN AND SECTIONS OF TOMB 877 AND 989 . . . . .	34
33. TOMB 877 A, LOOKING WEST FROM ENTRANCE, SHOWING LB II POTTERY SEPARATED BY STERILE EARTH FROM MB I POTTERY . . . . .	35
34. TOMB 877 A AFTER REMOVAL OF LB II POTTERY (EXCEPT P 2926), LOOKING WEST FROM ENTRANCE . . . . .	35
35. TOMB 877 B AND PART OF C FROM SOUTH, SHOWING LB II POTTERY AND TWO MB I "TEAPOTS" . . . . .	36
36. TOMB 877 B FROM NORTHEAST, SHOWING LB II OBJECTS AND A MB I "TEAPOT" . . . . .	37
37. TOMB 877 B, LOOKING NORTHEAST INTO CHAMBER C . . . . .	37
38. TOMB 989 A FROM WEST-NORTHWEST, SHOWING LB II POTTERY . . . . .	38
39. TOMB 989 A FROM NORTHWEST, SHOWING LB II POTTERY FOUND AFTER REMOVAL OF THAT SHOWN IN FIG. 38 . . . . .	38
40. TOMB 989 C FROM NORTHWEST, SHOWING LB II POTTERY . . . . .	39

## LIST OF ILLUSTRATIONS

xix

	PAGE
41. TOMB 989 C FROM NORTHEAST, SHOWING LB II POTTERY . . . . .	39
42. PLAN AND SECTION OF TOMB 878 . . . . .	41
43. PLAN AND SECTIONS OF TOMBS 880, 884, AND 1098 . . . . .	42
44. TOMB 1098, LOOKING THROUGH HOLE IN ROOF, SHOWING MB I BURIAL IN CHAMBER A . . . . .	43
45. PLAN AND SECTIONS OF TOMB 891 . . . . .	44
46. PLAN AND SECTION OF TOMB 922 . . . . .	45
47. PLAN AND SECTIONS OF TOMB 1014 . . . . .	46
48. PLAN AND SECTION OF TOMB 1120 . . . . .	48
49. PLAN AND SECTION OF TOMB 24 . . . . .	49
50. PLAN AND SECTION OF TOMB 42 . . . . .	50
51. PLAN AND SECTION OF TOMB 45 . . . . .	51
52. TOMB 49, SHOWING MB II POTTERY . . . . .	52
53. PLANS AND SECTION OF TOMB 51 . . . . .	53
54. TOMB 51 BEFORE REMOVAL OF ENTRANCE BLOCKING AND ROOF . . . . .	54
55. TOMB 51 AFTER REMOVAL OF ENTRANCE BLOCKING AND ROOF, SHOWING MB II POTTERY . . . . .	54
56. TOMB 51 FROM ABOVE, SHOWING MB II POTTERY . . . . .	55
57. TOMB 234 WITH MB II POTTERY AND OFFERING-PLACE 235, SHOWING BASALT BOWL BESIDE EACH . . . . .	56
58. BASALT BOWLS FROM TOMB 234 AND OFFERING-PLACE 235 . . . . .	56
59. TOMB 244 . . . . .	57
60. TOMB 247, SHOWING CHILD SKELETON AND MB II JUGS . . . . .	57
61. TOMB 251, SHOWING SKELETAL REMAINS AND MB II POTTERY . . . . .	58
62. TOMB 252 . . . . .	58
63. TOMB 253, SHOWING MB II POTTERY . . . . .	59
64. TOMB 254, SHOWING MB II BURIAL . . . . .	59
65. GROUP OF TOMBS IN SQUARES R-S 15, FROM SOUTHEAST . . . . .	60
66. TOMB 257, POT BURIAL OF AN INFANT . . . . .	60
67. TOMB 258, SHOWING SKELETON AND MB II POTTERY . . . . .	61
68. TOMB 645, MB II JAR BURIAL OF AN INFANT . . . . .	62
69. TOMB 868, MB II CHILD BURIAL IN DÉBRIS . . . . .	62
70. PLAN AND SECTIONS OF TOMBS 911-12 . . . . .	63
71. TOMB 911 A, SHOWING MB II AND LB II TOMB FURNITURE . . . . .	64
72. SOUTHEAST CORNER OF TOMB 911 A, SHOWING A MB I JUG ON THE ROCK FLOOR AND SKELETON H 116 WITH MB II POTTERY . . . . .	65
73. TOMB 911 A, SHOWING MB II AND LB II TOMB FURNITURE . . . . .	66
74. TOMB 911 A AFTER REMOVAL OF FURNITURE SHOWN IN FIG. 71 . . . . .	66
75. SHAFT OF TOMB 912, SHOWING LB II POTTERY . . . . .	68
76. TOMB 912 A, SHOWING LB II OBJECTS AND A MB II JUG . . . . .	69
77. LB II BASALT PLATE FROM TOMB 912 A . . . . .	69
78. TOMB 912 B, LOOKING WEST-NORTHWEST FROM ENTRANCE, SHOWING MB II AND LB II OBJECTS . . . . .	70
79. TOMB 912 B FROM EAST, AFTER REMOVAL OF FURNITURE SHOWN IN FIG. 78 . . . . .	70
80. TOMB 912 D, LOOKING SOUTHWEST FROM ENTRANCE, SHOWING MB II AND LB II OBJECTS . . . . .	71
81. TOMB 912 D FROM WEST, SHOWING MB II AND LB II OBJECTS . . . . .	71
82. PLAN AND SECTION OF TOMB 3 . . . . .	73
83. TOMBS 37-38 AS EXPOSED BY ROOF COLLAPSE, WITH SHAFT OF TOMB 41 VISIBLE BEYOND . . . . .	74
84. GENERALIZED PLAN AND SECTIONS OF TOMB 37 . . . . .	75
85. PLAN OF KILN 22 IN TOMB 37 . . . . .	76
86. MI POTTERY JAR-STAND FOUND IN KILN 22 . . . . .	76
87. RECONSTRUCTION OF MI POTTERY BATH FROM FRAGMENTS FOUND IN KILN 22 . . . . .	76
88. KILN 23 IN TOMB 37 . . . . .	78
89. PLAN AND SECTION OF KILN 23, SHOWING DETAILS OF FLUE SYSTEM . . . . .	78
90. PLAN OF TOMB 37 B, SHOWING INFANT SKELETON WITH IRON BRACELET ON LEFT ARM . . . . .	78
91. PLAN AND SECTION OF TOMB 37 C 1-2 . . . . .	79
92. TOMB 37 M, SHOWING LB I JAR BURIAL . . . . .	80
93. PLAN OF TOMB 37 M . . . . .	80
94. MI JARS FOUND IN TOMB 37 N OUTSIDE OF KILN 33 . . . . .	81
95. TOMB 75 FROM EAST, SHOWING SKELETAL REMAINS AND LB I POTTERY . . . . .	82

	PAGE
96. ENTRANCE TO Tomb 77 . . . . .	83
97. INTERIOR OF Tomb 77 FROM EAST . . . . .	83
98. PLAN OF Tomb 77 . . . . .	84
99. Tomb 78 FROM NORTHEAST, SHOWING SKELETAL REMAINS AND LB I POTTERY . . . . .	84
100. Tomb 855 FROM SOUTH, WITH SKELETON H 144 IN Tomb 856 VISIBLE IN LOWER RIGHT-HAND CORNER . . . . .	85
101. Tomb 855 FROM SOUTH AFTER REMOVAL OF OBJECTS AND SKELETAL REMAINS SHOWN IN FIG. 100 . . . . .	86
102. Tomb 855 FROM SOUTH AFTER REMOVAL OF POTTERY SHOWN IN FIG. 101 . . . . .	86
103. Tomb 921 FROM EAST, SHOWING LB I CHILD BURIAL . . . . .	88
104. PLAN AND SECTION OF Tomb 1100 . . . . .	89
105. Tomb 1100 D FROM NORTH, WITH PART OF CHAMBER A IN FOREGROUND . . . . .	90
106. Tomb 1100 A AND B FROM SOUTHEAST . . . . .	90
107. Tomb 1100 C FROM SOUTHWEST, WITH PART OF CHAMBER A IN FOREGROUND . . . . .	91
108. Tomb 1100 A AND D FROM NORTH AFTER REMOVAL OF REMAINS SHOWN IN FIG. 105 . . . . .	91
109. Tomb 1100 A, LOOKING NORTH FROM CHAMBER D, AFTER REMOVAL OF REMAINS SHOWN IN FIG. 106 . . . . .	92
110. Tomb 1100 A AND C FROM SOUTHWEST AFTER REMOVAL OF REMAINS SHOWN IN FIG. 107 . . . . .	92
111. DESIGN ON A JUG FROM Tomb 1100 A . . . . .	93
112. PLAN AND SECTION OF TOMBS 1141 AND 1145 . . . . .	93
113. Tomb 1141, SHOWING SKELETON H 140 AND POTTERY RESTING ON DÉBRIS AGAINST WALL BETWEEN TOMBS 1141 AND 1145 B . . . . .	94
114. Tomb 1145 FROM SOUTHEAST, SHOWING BLOCKING WALL BETWEEN CHAMBERS A AND B . . . . .	95
115. Tomb 1145 A FROM NORTHEAST . . . . .	96
116. Tomb 1145 A FROM NORTHEAST AFTER REMOVAL OF POTTERY SHOWN IN FIG. 115 . . . . .	96
117. Tomb 1145 B FROM SOUTHWEST, SHOWING SKELETAL REMAINS AND LB I POTTERY, WITH BLOCKING WALL BETWEEN TOMBS 1145 B AND 1141 VISIBLE AT RIGHT . . . . .	97
118. Tomb 1145 B FROM SOUTHWEST, SHOWING SKELETAL REMAINS AND LB I OBJECTS FOUND AFTER REMOVAL OF POTTERY SHOWN IN FIG. 117 . . . . .	97
119. Tomb 1145 B FROM SOUTHWEST AFTER REMOVAL OF REMAINS SHOWN IN FIG. 118 . . . . .	98
120. SCHEMATIC DRAWING OF SKELETONS IN Tomb 1145 B . . . . .	98
121. Tomb 1178 FROM NORTHEAST . . . . .	99
122. PLAN AND SECTION OF Tomb 4 . . . . .	100
123. Tomb 8, WITH LB II POTTERY . . . . .	101
124. PLAN AND SECTION OF Tomb 26 . . . . .	102
125. Tomb 26, SHOWING UNDISTURBED LB II POTTERY IN FOREGROUND . . . . .	104
126. VERTICAL SHAFT AND ENTRANCE OF Tomb 39 AS EXPOSED BY COLLAPSE OF SURFACE ROCK INTO TOMBS 26 AND 40 . . . . .	104
127. BASALT GRINDERS FROM Tomb 26 . . . . .	104
128. PLAN AND SECTION OF Tomb 36 . . . . .	105
129. PLAN AND SECTION OF Tomb 59 . . . . .	107
130. ENTRANCES TO Tomb 59 . . . . .	108
131. Tomb 64 AND ENTRANCE TO Tomb 63, SHOWING STONES BLOCKING HOLE FROM Tomb 64 INTO Tomb 63 . . . . .	108
132. PLAN AND SECTION OF Tomb 63 AND PLAN OF Tomb 64 . . . . .	109
133. Tomb 63, LOOKING WEST-NORTHWEST FROM ENTRANCE . . . . .	110
134. Tomb 73 FROM SOUTH . . . . .	112
135. Tomb 73 FROM NORTH-NORTHEAST, SHOWING REMAINS OF ROOF AND WALL 220 . . . . .	112
136. PLAN AND SECTIONS OF Tomb 84 . . . . .	113
137. SHAFT OF Tomb 84, SHOWING BLOCKING STONE AT BOTTOM . . . . .	114
138. Tomb 84 B . . . . .	114
139. Tomb 84, LOOKING NORTH FROM CHAMBER B . . . . .	115
140. Tomb 1250 FROM SOUTHWEST, SHOWING LB II POTTERY . . . . .	116
141. Tomb 17, ROCK-CUT GRAVE . . . . .	117
142. PLAN AND SECTION OF Tomb 17 . . . . .	117
143. PLAN AND SECTION OF Tomb 39 . . . . .	118
144. Tomb 39 A . . . . .	119
145. Tomb 61 FROM NORTHWEST . . . . .	120
146. Tomb 62 FROM SOUTHEAST . . . . .	120
147. Tomb 71 FROM NORTHWEST . . . . .	120

## LIST OF ILLUSTRATIONS

xxi

	PAGE
148. TOMB 72 FROM EAST . . . . .	121
149. PLAN AND SECTION OF TOMB 221 . . . . .	122
150. TOMB 221 FROM SOUTHEAST . . . . .	123
151. TOMB 221 B FROM WEST . . . . .	123
152. TOMB 237 FROM SOUTH . . . . .	124
153. PLAN AND SECTIONS OF TOMB 1090 . . . . .	124
154. TOMB 1090 A, LOOKING SOUTHEAST . . . . .	125
155. TOMB 1090 C, LOOKING NORTH FROM ENTRANCE . . . . .	126
156. PLAN AND SECTION OF TOMB 5 . . . . .	128
157. TOMB 19 BEFORE REMOVAL OF COVER SLABS, FROM NORTHEAST . . . . .	129
158. PLANS AND SECTION OF TOMB 19 . . . . .	130
159. TOMB 19 FROM NORTHWEST, SHOWING LATER BURIAL WITH THREE EARLIER SKELETONS AND ROMAN GLASSWARE UNDERNEATH . . . . .	130
160. TOMB 19 AFTER REMOVAL OF LATER BURIAL, FROM NORTHWEST . . . . .	130
161. TOMB 232 WITH UPPERMOST SKELETON AND SKULL OF MIDDLE SKELETON EXPOSED . . . . .	131
162. TOMB 232 WITH MIDDLE SKELETON AND PART OF LOWEST SKELETON EXPOSED . . . . .	131
163. TOMB 236 . . . . .	132
164. PLAN AND SECTIONS OF TOMB 854 . . . . .	133
165. TOMB 854 . . . . .	133
166. PLAN AND SECTIONS OF TOMB 857 . . . . .	133
167. TOMB 950 FROM SOUTHEAST . . . . .	134
168. PERSPECTIVE DRAWING OF A NORMAL SHAFT TOMB . . . . .	136
169. EI I GOLD MEDALLION WITH "ROYAL" OR "CAPPADOCIAN" SYMBOL . . . . .	162
170. SPEARHEADS . . . . .	163
171. DAGGER BLADES AND POMMELS . . . . .	facing 164
172. "BRONZE" AND IRON KNIFE BLADES . . . . .	166
173. AXHEADS AND OTHER BLADES . . . . .	167
174. TOGGLE PINS . . . . .	169
175. WHORLS AND A SPINDLE . . . . .	171
176. FINGER RINGS . . . . .	172
177. LB II GOLD RING WITH OLD CANAANITE CHARACTERS . . . . .	174
178. EARRINGS . . . . .	177
179. BRACELETS . . . . .	179
180-83. MEGIDDO AND NUZI CYLINDER SEAL IMPRESSIONS . . . . .	182-85
184. EGYPTIAN "ALABASTER" AND DIORITE VESSELS . . . . .	187
185. FAYENCE VESSELS . . . . .	188
186. "BRONZE" VESSELS AND A "BRONZE" OFFERING-STAND . . . . .	189
187. CHALCOLITHIC AND LB I MANDIBLES . . . . .	193
188. CHALCOLITHIC FEMALE SKULL FROM TOMB 903 UPPER . . . . .	193
189-90. CHALCOLITHIC MALE SKULL FROM TOMB 903 UPPER . . . . .	194-95
191. CHALCOLITHIC FEMALE SKULL FROM TOMB 910 A . . . . .	196
192. CHALCOLITHIC MALE SKULL FROM TOMB 1103 . . . . .	197
193. EB (STAGE 0-I) ADOLESCENT FEMALE SKULL FROM TOMB 1101 B LOWER . . . . .	198
194. EB (STAGE 0-I) MALE SKULL FROM TOMB 1101 B LOWER . . . . .	199
195-96. LB I MALE SKULLS FROM TOMB 1100 A . . . . .	200-201
197. LB FEMALE SKULL FROM TOMB 36 B . . . . .	202
198. EI I MALE SKULL FROM TOMB 1090 C . . . . .	203
199. MI MALE SKULL FROM TOMB 1265 . . . . .	204
200. LI OR CLASSICAL MALE SKULL FROM TOMB 232 . . . . .	205
201. LI OR CLASSICAL FEMALE SKULL FROM TOMB 232 . . . . .	206
202. LI OR CLASSICAL MALE SKULL FROM TOMB 232 . . . . .	207
203. MISCELLANEOUS SKULLS. TOP VIEWS . . . . .	208
204. <i>Bos</i> cf. <i>longifrons</i> . PORTION OF LEFT HORN CORE, ANTERIOR VIEW AND TRANSVERSE SECTION . . . . .	211
205. MAMBER GOAT. PORTION OF RIGHT HORN CORE, ANTERIOR VIEW AND TRANSVERSE SECTION . . . . .	211
206. <i>Ovis</i> sp. LEFT HORN CORE, DORSAL VIEW AND TRANSVERSE SECTION . . . . .	212

## LIST OF ABBREVIATIONS

<i>AAA</i>	Annals of archaeology and anthropology (Liverpool, 1908—).
<i>AASOR</i>	American Schools of Oriental Research. Annual (New Haven, 1920—).
<i>AJA</i>	American journal of archaeology. . . . The journal of the Archaeological Institute of America (Baltimore, etc., 1885—).
<i>AJSL</i>	American journal of Semitic languages and literatures (Chicago, 1884—).
<i>Beth-Pelet I</i>	Petrie, W. M. F. Beth-Pelet I (Tell Fara) (London, 1930).
<i>Beth-Pelet II</i>	MacDonald, Eann, Starkey, J. L., and Harding, Lankester. Beth-Pelet II (London, 1932).
FitzGerald, <i>Beth-Shan Pottery</i>	FitzGerald, G. M. The four Canaanite temples of Beth-Shan. Part II. The pottery (Publications of the Palestine Section of the Museum of the University of Pennsylvania II [Philadelphia, 1930]).
Gjerstad, <i>Studies</i>	Gjerstad, Einar. Studies on prehistoric Cyprus (Uppsala, 1926).
Gjerstad <i>et al.</i> , <i>Cyprus</i>	Gjerstad, Einar, Lindros, John, Sjöqvist, Erik, and Westholm, Alfred. The Swedish Cyprus Expedition (Stockholm, 1934—).
Hall, <i>Scarabs</i>	British Museum. Catalogue of Egyptian scarabs, etc. I. Royal scarabs, by H. R. Hall (London, 1913).
<i>ILN</i>	The illustrated London news (London, 1842—).
<i>JEA</i>	The journal of Egyptian archaeology (London, 1914—).
<i>JEN</i>	Chiera, Edward. Joint Expedition with the Iraq Museum at Nuzi (American Schools of Oriental Research. Publications of the Baghdad School. Texts [5 vols.; Paris, 1927–34]).
<i>JENu</i>	Joint Expedition of the American Schools of Oriental Research with the Iraq Museum at Nuzi. Unpublished texts.
<i>JPOS</i>	Palestine Oriental Society. The journal (Jerusalem, 1923—).
<i>JRAI</i>	Royal Anthropological Institute of Great Britain and Ireland. The journal (London, 1872—).
Macalister, <i>Gezer</i>	Macalister, R. A. Stewart. The excavation of Gezer, 1902–1905 and 1907–1909 (3 vols.; London, 1912).
<i>MJ</i>	Pennsylvania. University. University Museum. The museum journal (Philadelphia, 1910—).
<i>OIC</i>	Chicago. University. The Oriental Institute. Oriental Institute communications (Chicago, 1922—).
<i>OIC No. 4</i>	Fisher, Clarence S. The excavation of Armageddon (1929).
<i>OIC No. 9</i>	Guy, P. L. O. New light from Armageddon (1931).
<i>OIP</i>	Chicago. University. The Oriental Institute. Oriental Institute publications (Chicago, 1924—).
<i>OIP XIX</i>	Schmidt, Erich F. The Alishar Hüyük, seasons of 1928 and 1929. Part I (1932).
<i>OIP XXVI</i>	May, Herbert G. Material remains of the Megiddo cult (1935).
<i>OIP XXVIII–XXX</i>	Osten, H. H. von der. The Alishar Hüyük, seasons of 1930–32. Parts I–III (1937).
<i>OIP XLII</i>	Lamon, Robert S., and Shipton, Geoffrey M. Megiddo. I. Seasons of 1925–34. Strata I–V (1939).
<i>PEFQS</i>	Palestine Exploration Fund. Quarterly statement (London, 1869—).
Petrie, <i>Buttons</i>	Petrie, W. M. F. Buttons and design scarabs (London, 1925).
Petrie, <i>Gaza</i>	Petrie, W. M. F. Ancient Gaza (4 vols.; London, 1931–34).
<i>QDAP</i>	Palestine. Department of Antiquities. The quarterly (Jerusalem, 1931—).
<i>RA</i>	Revue d'assyriologie et d'archéologie orientale (Paris, 1884—).
Rowe, <i>Scarabs</i>	Palestine Archaeological Museum. A catalogue of Egyptian scarabs, scaraboids, seals and amulets, by Alan Rowe (Le Caire, 1936).

<i>SAOC</i>	Chicago. University. The Oriental Institute. Studies in ancient oriental civilization (Chicago, 1931—).
<i>SAOC</i> No. 4	Frankfort, Henri. Archeology and the Sumerian problem (1932).
<i>SAOC</i> No. 10	Engberg, Robert M., and Shipton, Geoffrey M. Notes on the Chalcolithic and Early Bronze Age pottery of Megiddo (1934).
S.D.	Sequence Date(s), as devised for predynastic Egypt by Sir Flinders Petrie.
<i>WVDOG</i>	Deutsche Orient-Gesellschaft, <i>Berlin</i> . Wissenschaftliche Veröffentlichungen (Leipzig, 1900—).
<i>ZAS</i>	Zeitschrift für ägyptische Sprache und Altertumskunde (Leipzig, 1863—).

# I

## INTRODUCTION

### THE SITE

Tell el-Mutesellim (Fig. 1) lies on the southwest side of the Plain of Esdraelon at the point, some twenty miles from the port of Haifa, where the ancient road from Egypt to Syria and Mesopotamia crossed that from Judea to Phoenicia, and it guards the pass by which the former crossed the Carmel Ridge after leaving the coastal plain of Sharon. The topography



FIG. 1.—MEGIDDO AND THE PLAIN OF ESDRAELON, LOOKING NORTH-NORTHEAST FROM THE NORTHEAST END OF WADI 'ARAH, WITH THE VILLAGE OF LEJJUN IN THE FOREGROUND AND THE HILLS OF NAZARETH IN THE BACKGROUND

of its surroundings has been described in *OIC* Nos. 4 and 9, and a reasoned discussion of the identity of the site with Megiddo or Armageddon will be found in Sir George Adam Smith, *The Historical Geography of the Holy Land* (25th ed.; New York, 1932) pages 411 f., note to page 386. [See further Harold H. Nelson, *The Battle of Megiddo* (Chicago, 1913).]

When the generosity of Mr. John D. Rockefeller, Jr., made it possible for Professor James Henry Breasted to put into practice his long-cherished plan of having the tell excavated and

Dr. Fisher went to the site in 1925 to undertake the work, he began by excavating to bedrock an area on the east slope of the mound on which to deposit the débris which would result from the excavation of the mound itself. On my taking over in May, 1927, this area had already been almost completely filled, and all but two of the tombs discovered in it had been covered by the dump heap. One of the first things then to be done was, therefore, to enlarge the dumping-space. In doing this some thirty additional tombs were found. These tombs were not very complicated or difficult to dig, and there were few buildings or other remains of high interest in the area, so the work went quickly.

In 1929, after Mr. Rockefeller had visited the site with Professor Breasted, it was decided to acquire the whole mound, with a margin all round it. To begin with there had been leased only the southeastern part of the site. The next step was the removal of the surface soil, of which there was a very great quantity, one of the dump heaps which remained from Schumacher's earlier excavations amounting alone to some nine thousand tons. The dumping-space on the east slope was thus filled much more rapidly than had been anticipated at the time when it was first enlarged, and in spite of raising the level of the dump wherever possible and utilizing every corner available for the deposit of débris it became essential by the autumn of 1930 to provide still more space. A new area of about 3,750 square meters was marked off, thus bringing the total dumping-space up to about 15,000 square meters. This new area turned out to be by far the most prolific, for besides producing nearly forty more tombs, among them the richest of the shaft tombs, it contained numerous habitations, sometimes superposed, belonging to very early periods which go back well into the 4th millennium B.C.<sup>1</sup> It thus demanded very careful excavation, and the last of the tombs here published were not dug until 1932. It was only by the spring of 1933 that all the other remains were removed and it became certain that there were no more tombs within the area.

#### RECORDING AND NUMBERING

The basis for all recording connected with the excavations at Megiddo is the general plan of the site (Fig. 2) made on a scale of 1:1000, with contours marked at 2-meter intervals. It is covered by a grid of 25-meter squares, each identified by a letter and a number, for example U 17. The corners of the squares were accurately marked on the ground by means of pegs, and the northeast peg in each square bore the letter and number of that square. Only general features are shown on the 1:1000 plan, the remains found during excavation being ordinarily reproduced on a series of 1:200 plans each sheet of which contains sixteen 25-meter squares. In principle there is a separate 1:200 plan for each stratum of ruins on the mound itself, these strata being numbered downward from the surface in Roman numerals. Although the east slope was stratified in places, this stratification has no relationship with the majority of the tombs. It could not be correlated with the stratification on the tell, and therefore the strata on the east slope are distinguished by the prefix ES. Three such strata, ES I-III, are represented in squares Q-S 15-16 on Plate 1, which is a combination of all or parts of several 1:200 plans.

Since the character of the east slope with its numerous and considerable irregularities of rock surface is such that it cannot be represented on a plan so as to be readily understood, the latest area of it to be excavated is illustrated by an air-photo (Pl. 2)<sup>2</sup> instead of a plan. Some of this area was planned also and appears on Plate 1, with which a comparison may be made. On Plate 2 the pegs marking the corners of the squares have been joined, but this has not resulted in true squares since the rock slopes downward to the south and east. It is felt that a

<sup>1</sup> See SAOC No. 10.

<sup>2</sup> For methods used in taking such photographs at Megiddo see *Antiquity* VI (1932) 148-55.

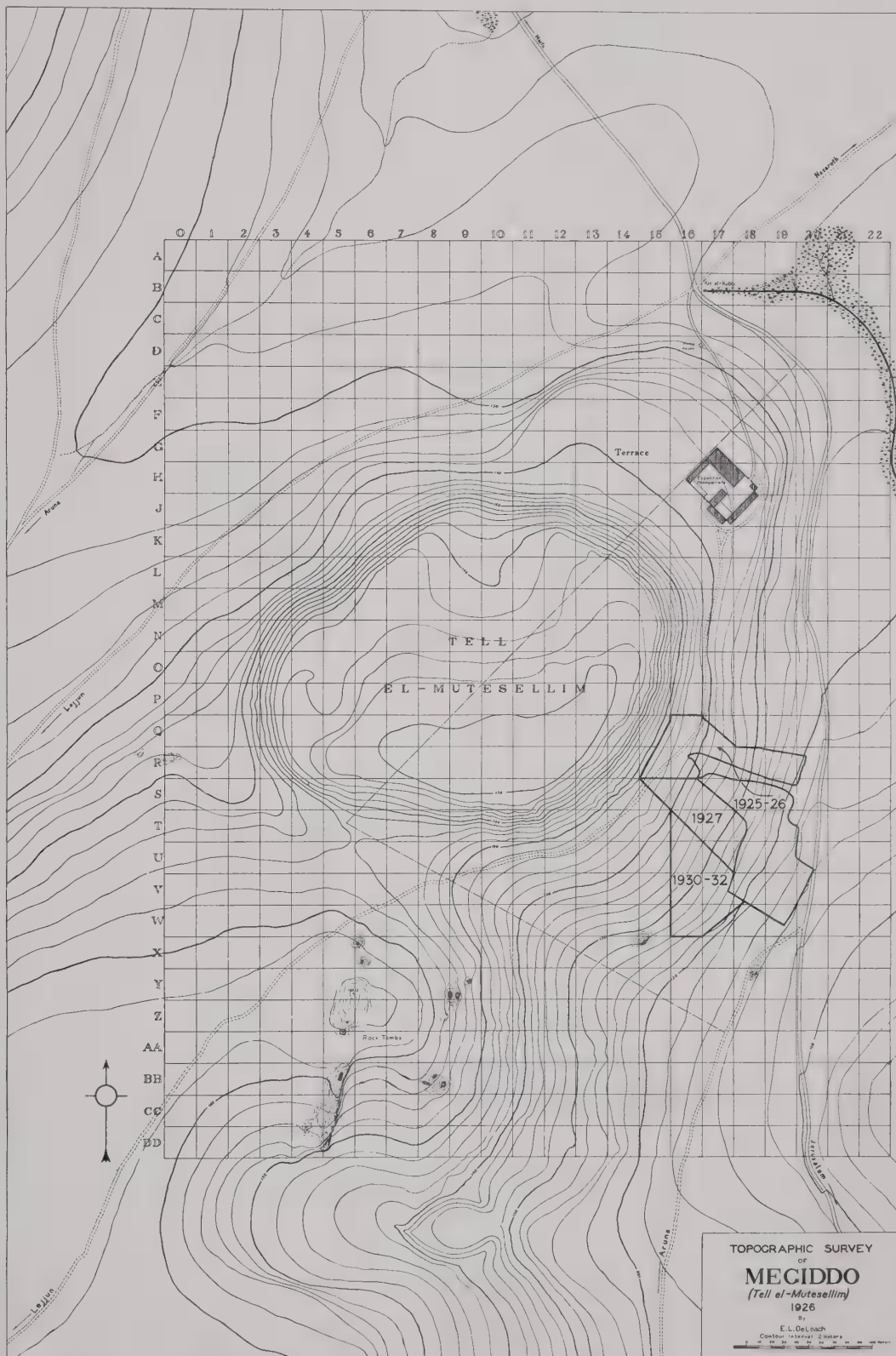

FIG. 2.—KEY PLAN OF MEGIDDO, SHOWING AREAS EXCAVATED ON THE EAST SLOPE (CF. PLS. 1-2). SCALE 1:5000

better impression is given by leaving the photo as it was taken than by correcting it in enlargement so as to obtain true squares but a distorted view of the site.

Levels have been freely taken at all stages of excavation, but they are not of high importance in the case of the east slope tombs, and it is felt that both the plans and the air-photo will be clearer if they are omitted.

While the letter and number of a square give approximately the position of any place on the site, some closer system of location is required. Prior to 1927 two sets of numbers were employed to locate places found. One of these was for rooms and on the mound was worked by strata, I 1 meaning the first room found in Stratum I, II 1, the first room found in Stratum II, and so on. The east slope counted more or less as a stratum, and the rooms there were numbered serially from 1 upward also. The other set of numbers was for tombs and likewise began with 1 but had the prefix T. It was found, however, that a room which at first sight appeared to belong to a particular stratum might subsequently prove to belong to another and that a place which to begin with looked like a tomb was not always a tomb.<sup>3</sup> Such occurrences made many corrections necessary throughout the records, and I therefore modified the system. Every structure was described as a "locus," a term which has since been adopted by several excavators. Each locus was, on discovery, given a serial number with no prefix (beginning with 201 so as not to interfere with the old system), and the stratum was omitted until it could be inserted with certainty. If, on excavation, a locus turned out to be a tomb, its number was given the prefix T.

During the first two seasons antiquities were numbered in a single series. In 1927 the system of registering antiquities was changed to consist of two registers, one with numbers prefixed by P (beginning with P 1) for pottery vessels, and the other with numbers prefixed by M (beginning with M 1) for all other articles. Human remains were given numbers prefixed by H.

#### ACCURACY OF THE RECORDS

##### SURVEY AND PLANS

A line of levels was run, in 1925, from the Mediterranean at Haifa, where mean sea-level was determined, to a bench mark on a solid concrete structure at the spring Ain el-Kubbi in square B 17 (see Fig. 2), the reading at which was 122.661 above mean sea-level. The instrument used was an 18-inch "Y" level by W. & L. E. Gurley, Troy, New York. This same instrument has been used for obtaining all levels since then. Other bench marks have from time to time been established on the site, and readings for these have been carried to three decimal places according to the normal surveying practice. But all other levels have been carried to only two decimal places (see "Measurements" below).

The 1:1000 general survey was made and the 25-meter squares laid out by means of a 5¼-inch transit by William Ainsworth & Sons, Denver, Colorado. For the 1:200 survey a Gurley plane table was used in conjunction with a 20-inch alidade with hair sights by W. F. Stanley & Co., 286 High Holborn, London, W.C. 1.

The planning of the tombs was done by such methods as best lent themselves to work in a very confined space, taping being the most usual.

##### DRAWINGS OF ANTIQUITIES

These are all based on careful measurements, the eye alone having been relied upon as little as possible. For such objects as lent themselves to its use a special instrument was employed. I first made a simple form of this for drawing the pottery found at Tell el-Amarnah in 1920-22,

<sup>3</sup> T. 65, T. 68-70, T. 74, and T. 81-83 were not tombs and hence are not treated in the present volume. The new system was begun after the excavation of T. 84.

when I designed also the more elaborate type which has been used at Megiddo since 1927. The latter was manufactured by W. F. Stanley & Co., London. It gives an accurate outline of the article to be drawn, by means of uprights and sliding horizontal rules both graduated so as to permit the drawing to be made to a predetermined scale on squared paper.

The thickness of pottery, often a difficult dimension to obtain where a vessel has a rim and is intact, has in such cases been measured by means of lock-joint transfer calipers (No. 36) made by the L. C. Starrett Co., Athol, Massachusetts.

#### MEASUREMENTS

A dimension which has been determined by means of an instrument which is capable of recording to the degree of accuracy implied (see below), such as a rule, tape, theodolite, or level, is considered a "measurement." All measurements are given in terms of meters and decimals of a meter, for example .05 or .050.

Where meters only are given, for example 23 meters, accuracy is implied to within half a meter. Where meters are followed by one decimal, for example 23.0, accuracy is implied to within five centimeters. Where meters are followed by two decimals, for example 23.00 or .05, accuracy is implied to within five millimeters. Where meters are followed by three decimals, for example 23.000 or .050, accuracy is implied to within half a millimeter.

Dimensions printed otherwise, for example seven meters or 25 cm., are not measurements as defined above, and only approximate accuracy is implied.

#### TERMINOLOGY

##### GENERAL

Certain expressions are used throughout this publication with the special meanings here given.

*Stratum*.—A more or less horizontal layer of the site belonging to a particular period. Such a layer is never called a level.

*Level*.—A surveying term used to indicate height above the Mediterranean. It may mean also a leveling instrument. It is never used for "stratum" as defined above.

*Square*.—One of the 25-meter squares into which the site is divided.

*Locus*.—Any place on the site about which a note has been made or in which an antiquity has been found. It defines a position more closely than "square."

At the request of the Palestine Department of Antiquities the state of every article discovered at Megiddo is indicated in the records, and such information is given in the present volume also, the following terms being used:

*Intact*.—The article appears to be undamaged.

*Intact(?)*.—The article is more likely to be undamaged than not. Such phrases as "intact but worn" and "intact but oxidized" have occasionally been used to indicate that, though no actual fracture has taken place, the article has suffered through friction, chemical action, or the like.

*Complete*.—The article is broken, but all fragments have been found.

*Fragmentary*.—The article cannot be properly described by any of the foregoing terms. Since the majority of articles are fragmentary, space has been saved by omitting this designation where it applies.

*Oxidized or badly oxidized*.—Occasionally used to describe metal objects the state of which is difficult to determine owing to oxidization.

##### POTTERY

"*Cup and saucer*."—We follow FitzGerald<sup>4</sup> in applying this term to pottery vessels such as Plate 58:17-18. Their use remains uncertain in spite of numerous suggestions. The fact that no specimens known to me show traces of fire is rather against the theory that they are incense-burners, lamps, candlesticks, or torch-holders. They are too unstable for jar-stands.

<sup>4</sup> FitzGerald, *Beth-Shan Pottery*, p. 3.

*Wet-smoothed.*—Rubbed with the wet hand before firing to produce a surface finish.

*Slip.*—Clay mixed with water to about the consistency of cream and applied as a coating to the surface before firing.

*Wash.*—A layer of color thinner than a slip applied to the surface before firing.

*Burnish.*—A more or less permanent shiny surface finish produced with a smooth hard implement such as a shell, a bone, or a pebble.

*Polish.*—A more or less temporary shiny surface finish.

Written descriptions of pottery can never be wholly satisfactory, but it is felt that something will have been gained if they are made consistent throughout the publication. The following formula has therefore been adopted:

First the state (see above) is given and then the dimensions which do not show in the illustrations (d. means diameter and t. means thickness). Next come notes on the following:

*Ware.*—This has been described as "very coarse," "coarse," "medium," "fine," or "very fine," the normal being "medium."

*Tempering.*—To indicate this precisely a microscopic or analytical examination would be necessary, and that of course is out of the question. An attempt to describe the tempering has been made by employing such terms as "many large light grits" or "few dark grits," but we ourselves are doubtful whether this will be of use. The normal is "some mixed grits." In the earliest pottery light grits were usually calcite—a material still in use in Palestine.<sup>5</sup> In later times limestone was commonly used for light grits.

*Workmanship.*—"Very well made," "well made," "fairly well made," "poorly made," or "very poorly made" gives the degree of excellence of this, the normal being "fairly well made."

*Degree of firing.*—This is indicated by the terms "very well fired," "well fired," "moderately fired," "lightly fired," or "very lightly fired," the normal being "moderately fired."

*Color of core and surface.*—It is exceedingly difficult to describe colors by the written word alone, and an attempt to overcome this difficulty has been made by matching objects with various color charts. It was by no means easy to find a chart to fulfil all the requirements, particularly those of pottery. The one which proved most suitable and from which we have taken the color names used throughout this volume is *Specimen Tints of Artists' Colours*, published by Winsor & Newton, 37-40 Rathbone Place, London, W. 1. The specimen slips in this chart are on mat paper, and each is divided into three shades. The top or darkest shade is called 1, the middle or medium shade 2, and the bottom or lightest shade 3. Thus for example "indian red 1" is considerably darker than "indian red 3," with "indian red 2" somewhere between; but all three are the same color.

*Surface finish.*—The commonest finishes are wet-smoothing (normal), slip, and wash (see above). Any of these may be burnished or polished.

*Decoration.*—In most cases we have not described the design itself, since that is clear in the illustrations, but have given only the type of decoration, such as incised or punctate, and the colors of painted decoration.

The normal description of a pot, aside from decoration, is "medium ware, some mixed grits, fairly well made, moderately fired, wet-smoothed, wheelmade." In order to save space any of these designations which apply have been omitted from the descriptions opposite the plates, and only departures from the normal description have been printed.

#### OTHER OBJECTS

Objects other than pottery are so diverse that they do not readily lend themselves to the use of a formula. For these the state (see above), dimensions which do not show in the illustrations, material, and color (see above) where it is not identified by the material are set down in regular order. Thereafter come whatever items of description may be necessary. A few other conventions used are explained below:

*"Bronze."*—This term is applied to metal objects which have not been analyzed and may be either bronze or copper.

*Composition.*—Unglazed siliceous ware.

*Egyptian "alabaster."*—Calcite.<sup>6</sup>

<sup>5</sup> See Grace M. Crowfoot in *PEFQS*, 1932, p. 183.

<sup>6</sup> See A. Lucas, *Ancient Egyptian Materials & Industries* (2d ed., revised; London, 1934) p. 56.

*Fayence*.—Glazed siliceous ware.<sup>7</sup>

*Quartz*.—Rock crystal.

*Beads*.—First the longitudinal section and then the transverse section is given. If the latter is circular it is not noted. The terms used in describing the shapes of beads are taken for the most part from Horace C. Beck, "Classification and nomenclature of beads and pendants" (*Archaeologia* LXXVII [Oxford, 1928] 1-76).

*Feluccas*.—Boat-shaped objects made of pottery (e.g. Pl. 158:1, 4, and 18). The name was given to such objects by our workmen because of their resemblance to small boats. They are generally reused potsherds, but some were specially made (e.g. Pl. 158:20). Some are perforated, others not. The fact that the edges of even the specially manufactured ones have been rubbed down and sometimes burnished by use indicates that they were implements. Perhaps they were used for scraping hides or in pottery-making. Macalister illustrates two specimens from Gezer<sup>8</sup> and suggests that they may have been jar-stoppers.<sup>9</sup> Schaeffer has found some at Ras Shamra and tells me that he wonders if they are not female idols. As to dating, we have none at Megiddo which we can place earlier than LB I, and we are doubtful whether they were used later than LB II.

*Hammers and rubbers*.—The same implement was frequently used for both hammering and rubbing or grinding. Where an object seems to have been meant primarily for a hammer and to have been used secondarily as a rubber it has been called a "hammer-rubber"; where the reverse seems to have been the case it has been called a "rubber-hammer."

*Weights*.—These were weighed on scales capable of recording accurately to within one-tenth of a gram. They were exposed to the same atmospheric conditions for some days before weighing, which was carried out with the thermometer at 62 degrees Fahrenheit. In describing them we have attempted by using the terms "good criterion," "fair criterion," "poor criterion," or "no criterion" to indicate how close the present weight is to the original and thus to express its degree of usefulness for determining the ancient standard. In using these terms we have taken into consideration the probable proportion of the missing part (if any) to the total weight. Only the following hematite weights, from T. 912 B, could be said to provide good criteria:

Pl. 129:11	0.7 grams	Pl. 129:18	3.8 grams
Pl. 129:15	2.8 grams	Pl. 129:22	8.3 grams
Pl. 129:16	3.2 grams	Pl. 129:23	9.4 grams
Pl. 129:19	3.4 grams		

Beyond the observation that 0.7 is a factor of 2.8 and within one point of being a factor of 3.4 and 8.3 no conclusion is to be drawn, unless it be that ancient weight-makers were not very accurate. When it is considered that ancient scales were not fine instruments, that the materials of which weights were made are hygroscopic to varying degrees, and that temperature and humidity were undoubtedly left out of account both in determining a standard and in comparing newly manufactured weights with it, one is probably safe in saying that there never was in ancient Palestine any precise standard.

#### ARCHEOLOGICAL CLASSIFICATION AND DATING

For our system of classification we have adopted the chronology commonly used for Palestine, with certain modifications (see table below). The Chalcolithic and Early Bronze periods are subdivided by "stages." Of these, Stages I-VII represent superimposed strata, numbered backward in time, uncovered in a domestic deposit on the east slope at Megiddo.<sup>10</sup> Stage 0-I provides a chronological position for a late development of Early Bronze pottery forms found in T. 1101-2 Lower.<sup>11</sup> Comparison of pottery from the earliest of these stages with that from neighboring countries, principally Egypt, strongly suggests that Stage VII is earlier than S.D. 53 (see p. 143).

It is to be realized that, so far as we now know from metal objects which have been analyzed, bronze was not used at Megiddo until Middle Bronze II (see p. 160). Since further excavation

<sup>7</sup> See *ibid.* p. 101.

<sup>8</sup> Macalister, *Gezer* III, Pl. CXCI 5 and 12.

<sup>9</sup> *Ibid.* II 221.

<sup>10</sup> See SAOC No. 10. Buildings belonging to Stages IV and V may be seen in our Pl. 2 (in square U 16).

<sup>11</sup> See *ibid.* pp. 52-58 and chart, cols. 14 AA and 25 A.

and analyses may alter this, we have thought it best to adhere to the terminology used elsewhere in Palestine until such time as we may reach final conclusions.

Period	Date
Chalcolithic	Stages IV-VII . . . . . ?-ca. 3000 B.C.
Early Bronze (EB)	{ Stages I-IV } { Stage 0-I } . . . . . ca. 3000-2000 B.C.
Middle Bronze	{ MB I } { MB II } . . . . . ca. 2000-1600 B.C.
Late Bronze	{ LB I } { LB II } . . . . . ca. 1600-1200 B.C.
Early Iron*	{ EI I } { EI II } . . . . . ca. 1200-1000 B.C.
Middle Iron (MI)*	. . . . . ca. 1000-600 B.C.
Late Iron (LI)*	. . . . . ca. 600-300 B.C.
Hellenistic	. . . . . ca. 300-100 B.C.
Roman	. . . . . ca. 100 B.C.-A.D. 400

\* Pottery later than EI I has been dated by comparison with material from the stratified area at Megiddo (cf. *OIP* XLII). The terms "E-MI" (Early to Middle Iron) and "M-LI" (Middle to Late Iron) have been used where the precise period or stratum could not be ascertained.

## II

### TOMB DESCRIPTIONS

#### TOMBS 903 AND 1126-27 IN SQUARE V 16

Chalcolithic: T. 903 Upper, Stages IV-V; T. 903 Lower, Stages V-VII; T. 1126-27, Stage VII(?)  
Contents illustrated on Pls. 3 and 76-80

An irregularly shaped area, originally a cave, measuring roughly eight meters east and west by four meters north and south, with two great detached rocks (1232-33 in Fig. 3) on the north which were all that remained of the roof of the cave. The entrance was in the north-east corner.

Only mixed sherds were found in the topmost filling, which showed no stratification; but at a depth of 1.2 below the rock surface at the south a mass of human and some animal bones began to show (Fig. 4). As these were removed, there became visible a layer of lime, perhaps a floor, in which had been roughly cut a pit about four meters long (east to west) and about two and a half meters wide. This pit had been filled with human remains in the utmost disorder (Fig. 5), some of which had overflowed onto the lime "floor." When this second layer of bones had been removed, those illustrated in Figure 6 came to light. They mark the bottom of the T. 903 Upper deposit, which was some 40 cm. deep and was composed of the remains of some sixty individuals (e.g. Figs. 187:2-5, 188-90, and 203:3). Skulls were most frequent in the second layer (Fig. 5), and long bones in the third (Fig. 6). Some pottery vessels (Pl. 3:1-8), a pottery animal head (Pl. 76:7), and a metal object (Pl. 76:4) were mixed with the bones. The animal head, probably that of a cow, is one of the earliest figurines yet found at Megiddo.<sup>1</sup> The metal object has been proved by analysis to be copper (see p. 161). It may have been intrusive, for it was found in a position which it could have reached by way of the space between the rocks 1232 and 1233.

The disarticulation of almost all the bones in T. 903 Upper and the grouping of the skulls and of the long bones are entirely against its being a primary communal burial, and the almost certain explanation of their presence and of the disorder in which they were found is that they had been removed from tombs which it had been desired to reuse. It cannot be believed that they came from any of the shaft tombs, for not a single potsherd of the MB I period was found with them; and it is most unlikely that the shaft tombs had been cut prior to MB I. The most probable explanation is that they came from earlier tombs such as T. 910 (see pp. 17 f.) in square V 17 (see Pl. 2), and comparison of the skeletal remains from the two loci tends to confirm this. The pottery from T. 903 Upper belongs in the main to Stages IV-V. It could be either remains of vessels buried with the bodies in their original tombs and removed with the bones or, most unlikely, sherds more or less contemporary with the removal which got in accidentally.

Below T. 903 Upper was filling of earth and limestone chippings resting on a lime floor (1242; see Fig. 3). This deposit is called "T. 903 Lower," although the absence of human remains and the presence of animal bones, with a quantity of pottery and other objects, indicate that it represents a dwelling rather than a tomb. Among the potsherds found here were some which had

<sup>1</sup> See *OIP* XXVI, Pl. XXXVII.



FIG. 3.—TOMB 903 AFTER EXCAVATION, LOOKING NORTH



FIG. 4.—TOMB 903 UPPER FROM WEST, SHOWING FIRST LAYER OF BONES



FIG. 5.—TOMB 903 UPPER FROM EAST, SHOWING SECOND LAYER OF BONES



FIG. 6.—TOMB 903 UPPER FROM EAST, SHOWING THIRD LAYER OF BONES

been marked before firing (Fig. 7). Most of these are fragments of hole-mouth jars comparable to others found on the east slope at Megiddo<sup>2</sup> and at other sites in Palestine.<sup>3</sup> The marks on the sherds in the top two rows in Figure 7 may indicate the number of measures of grain contained in the vessels. The fact that identical marks have been found elsewhere<sup>4</sup> seems to be in favor of this suggestion and against the supposition that they were personal marks of the makers or owners of the vessels. In view of the uncertainty of their purpose "pottery marks" has been considered a better term for them than "potters' marks."

T. 1126 and T. 1127 (Fig. 8) were two burials which took place during the T. 903 Lower occupation, probably during the early part of it. They were intrusive below floor 1242, and T. 1127 (Fig. 9) at least was older than the deposit on that floor. Both skeletons were fully contracted on the right side, that in T. 1126, an adult male (Fig. 10), with head to south, and that in T. 1127, an adolescent, with head to northeast. The only object found with these bur-

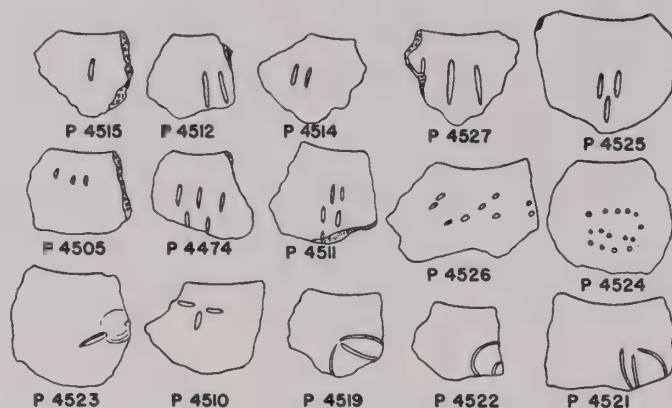

FIG. 7.—SHERDS BEARING POTTERY MARKS, FROM TOMB 903 LOWER. SCALE, 1:5

ials was a rough flint (not illustrated) lying between the knees of the skeleton in T. 1127. It was after the T. 903 Lower occupation that the cave roof, of which rocks 1232-33 (see Fig. 3) formed part, fell.

The skeleton of a cow (1125; see Fig. 8), with head and fore part missing, which lay slightly higher than the floor 1242 is probably to be associated with T. 903 Lower. It is, however, possible that certain cow bones found in T. 903 Upper belong to it and that it is contemporary with that deposit.

Below the floor 1242 there was a more or less stratified deposit of limestone chippings, as much as two meters thick in places, which rested upon the rock (see Fig. 3). No sherds or artifacts of any sort were found here, but a few small pieces of basalt were observed. No tool marks could be detected on the chippings. At one point there was a small pocket of dark earth with a little charcoal and several frontal fragments of a skull. Their presence seemed due to infiltration.

#### TOMB 910 IN SQUARE V 17

Tomb, Chalcolithic (Stages IV-V or earlier); contents, Chalcolithic and EB (Stages I-VII)  
Contents illustrated on Pls. 4 and 81-83

A rock-cut tomb entered by a low doorway from an antechamber (C). Beyond the outer sill of C the rock had been cut smooth for some distance to form an approach (Fig. 11). There are

<sup>2</sup> See SAOC No. 10, chart, col. 12 E.

<sup>3</sup> E.g. Frederick Jones Bliss and R. A. Stewart Macalister, *Excavations in Palestine during the Years 1898-1900* (London, 1902) Pl. 29.

<sup>4</sup> E.g. Bliss, *A Mound of Many Cities* (New York and London, 1894) pp. 21-23.



FIG. 8.—TOMB 903 FROM WEST, SHOWING TOMBS 1126-27 AND THE SKELETON OF A COW (1125). THE STEPS WERE CUT FOR EXCAVATION PURPOSES



FIG. 9.—TOMB 1127, WITH SKELETON H 87 *in situ*



FIG. 10.—TOMB 1126, WITH SKELETON H 88 *in situ*



FIG. 11.—ENTRANCE TO TOMB 910 (CF. FIG. 14)



FIG. 12.—TOMB 910, LOOKING NORTHWEST FROM CHAMBER A

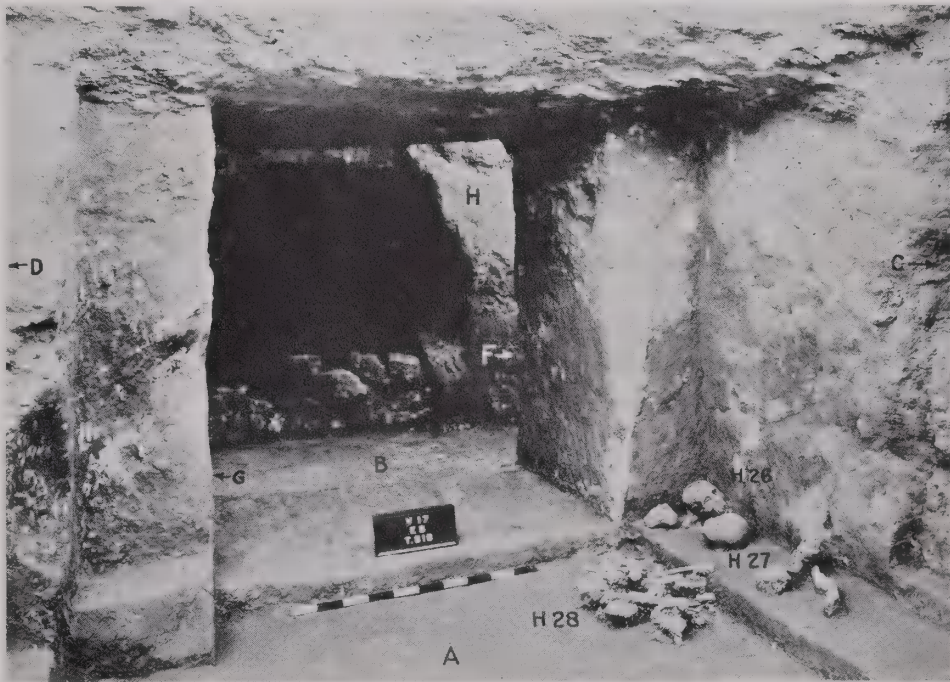

FIG. 13.—TOMB 910, SHOWING SKELETAL REMAINS IN NORTH CORNER OF CHAMBER A

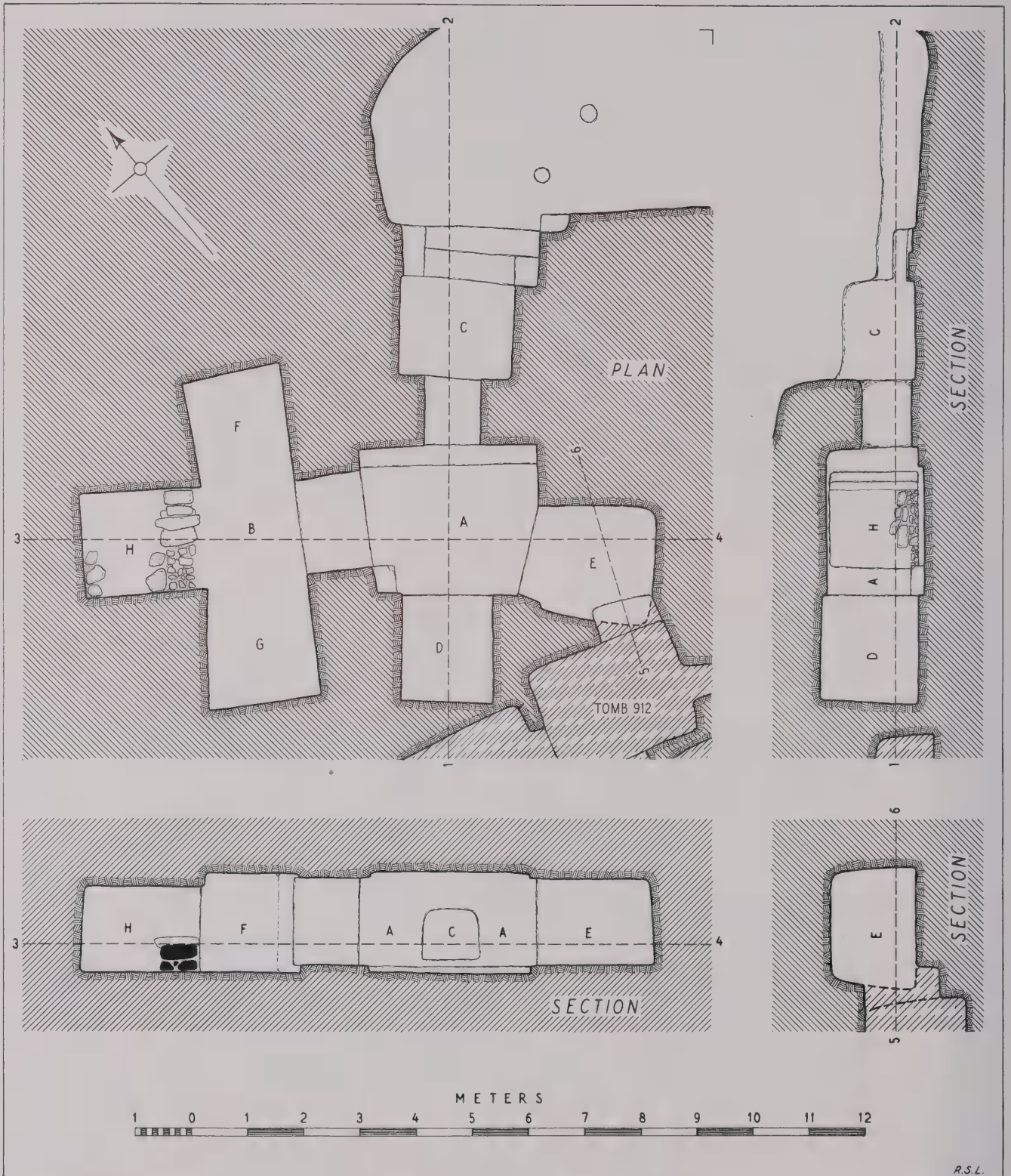

FIG. 14.—PLAN AND SECTIONS OF TOMB 910. SCALE, 1:100

sills between chambers C and A and between A and B also. The floors of D and E are practically level with the sills, as is the low platform along the northeast side of A (Figs. 12–13).

The cutting of this tomb as a whole is better than that of any other on the east slope. The walls of the chambers are very straight and in several cases make good right angles with one another (Fig. 14). But it is surprising that in other cases the angles are by no means right angles, so that the plan is irregular. There is, however, no reason to think that the chambers were not all contemporary. The walls incline inward toward the top, but not to so great a degree as those of the MB I shaft tombs. They have excellently finished surfaces upon which no tool marks could be detected. The upper part of the southeast wall of D had evidently been of faulty rock, for the rock had been removed and replaced with masonry (Fig. 15) which had been covered with plaster so smooth and so like the rock itself that it could scarcely be dis-

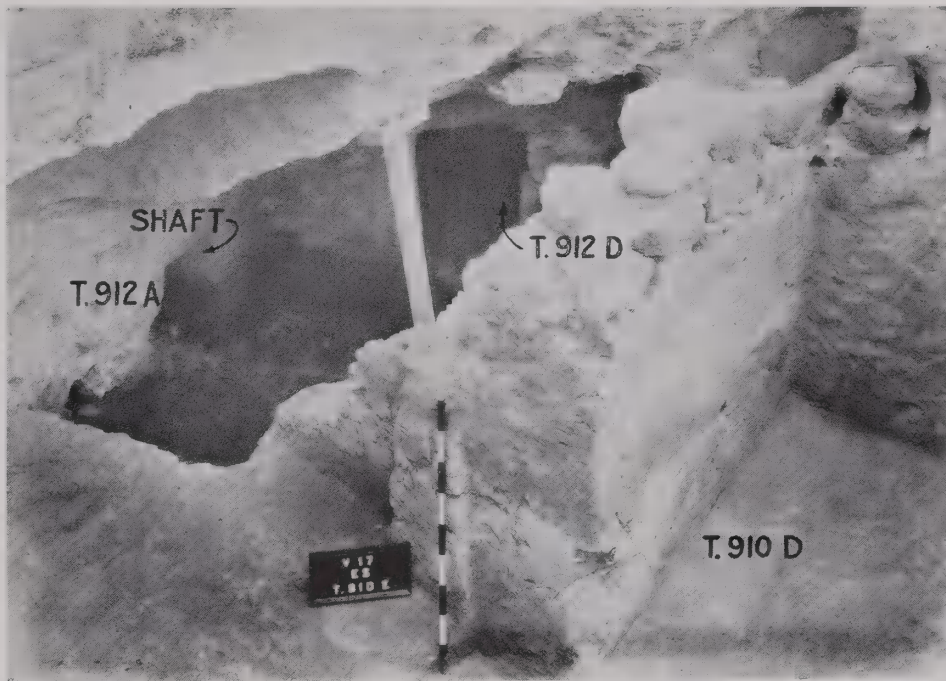

FIG. 15.—TOMB 910, LOOKING SOUTH FROM CHAMBER A INTO TOMB 912 (CF. FIG. 14). NOTE MASONRY (AFTER REMOVAL OF PLASTER) ON TOP OF ROCK WALL IN CHAMBER D

tinguished from it. There was a low wall of rubble across the mouth of H, and there had perhaps been a doorway at the southwest end of this (see Fig. 14).

The roof was broken away above C, D, G, and parts of A and E. Large fragments of it lying on the floor of A, with nothing else under them, showed that in this chamber at any rate the burials had been for the most part removed and that the middle of the floor was clear at the time of the fall. In this chamber the filling had, of course, accumulated on top of the fallen roof. But in the other roofless chambers the fall had been removed before the filling got in, except in G, where a layer of crushed limestone some 30 cm. above the rock suggested that part of the fallen roof had been allowed to remain and had been flattened out to form a floor for habitation. But no pottery could be said to belong definitely to this floor, and only one potsherd was found below it.

None of the pottery from T. 910 can be certainly associated with the burials (see below).

The few sherds found on the rock floor in A (Pls. 4:1-4 and 81:1-6) and G (Pl. 81:7) belong to Stages V-VI, but pottery from the same stages was by no means absent from the débris which completely filled all the chambers. This débris showed no stratification, and most of the pottery in it was very fragmentary. Jar P 3770 (Pl. 4:13), however, which belongs to Stages I-III, was almost complete. It was found standing upright about 30 cm. below the roof in the doorway between A and B, and P 5038 (Pl. 4:30), which was intact and should be at least as late as P 3770, was found in a similar position and at the same height in E. No floor could be detected at this level in either chamber.

An unfinished tomb shaft, T. 913 (see p. 45), had broken into F, and T. 912 (see p. 69) had encroached upon the southern corner of E (see Figs. 14-15). The wall of room 1211 (see Pl. 2), which belongs to Stages III-IV, had been built on top of the débris which had accumulated in G.

Skeletal remains (e.g. Figs. 187:1 and 191) were found on the floor of every chamber except F. All were lying either in corners or against walls, those in A (see Fig. 13) being the most distant from a wall. There was no order among the bones, and no skeleton was at all complete. The skeletal remains may safely be presumed to belong to the original burials. Their position and their fragmentary state suggest that they were merely what had been overlooked in a general clearance made before the roof fell. It is possible that bones which may have been then removed were placed in T. 903 Upper, since certain resemblances between skulls from the two loci have been noted. In T. 903 Upper were found parallels to some of the pottery from T. 910 (cf. Pl. 3 with Pl. 4); but, since much if not all of the latter was undoubtedly introduced with the filling, comparison is not very helpful.

The rubble wall in H and the layer of lime in G suggest that the tomb was in use as a dwelling for a while after the burials had been removed, but no clear remains of such an occupation were to be remarked. Sherds found in the wall (Pl. 4:41-42) do not necessarily date it.

After the wall in H had been reduced to its height as found, filling accumulated until it was high enough in G for room 1211 to be built on top of it during Stages III-IV. But in A and E its deposit was arrested until Stages I-III, when P 3770 and P 5038 were put in. This occupation was followed by the cutting of T. 912 and T. 913 during MB I.

T. 910 must be earlier than Stages III-IV because of the superposition of room 1211. Stages IV-V would suit it quite well, but it might be earlier still.

#### TOMB 1103 IN SQUARE V 16

Chalcolithic (Stages IV-V)

Contents illustrated on Pl. 83

A cleft in the rock (Fig. 16), partly natural and partly artificial, running roughly east and west. Maximum depth 2 meters; width .5 at west end, broadening to 1.6 toward the east; length 4.6 to the point where a grain pit or cistern (locus 1112) broke into it on the east. It was not a tomb in the ordinary sense of the word but contained a quantity of human bones (e.g. Figs. 192 and 203:1-2), representing about twenty individuals, in no order at all. In this it resembles T. 903 Upper (see p. 9). The few sherds found in T. 1103 (not illustrated) show that it belongs to the same time, that is, Stages IV-V, as T. 903 Upper.

#### TOMB 1122 IN SQUARE V 17

Tomb, Chalcolithic (Stages IV-VII); contents: Shelf, Chalcolithic (Stages IV-VII); Upper, LB II  
Contents illustrated on Pls. 5 and 83-84

A very irregular cave, partly natural and partly artificial, measuring some seven by six meters, with a height of almost three meters in places. It could be entered by two holes in the

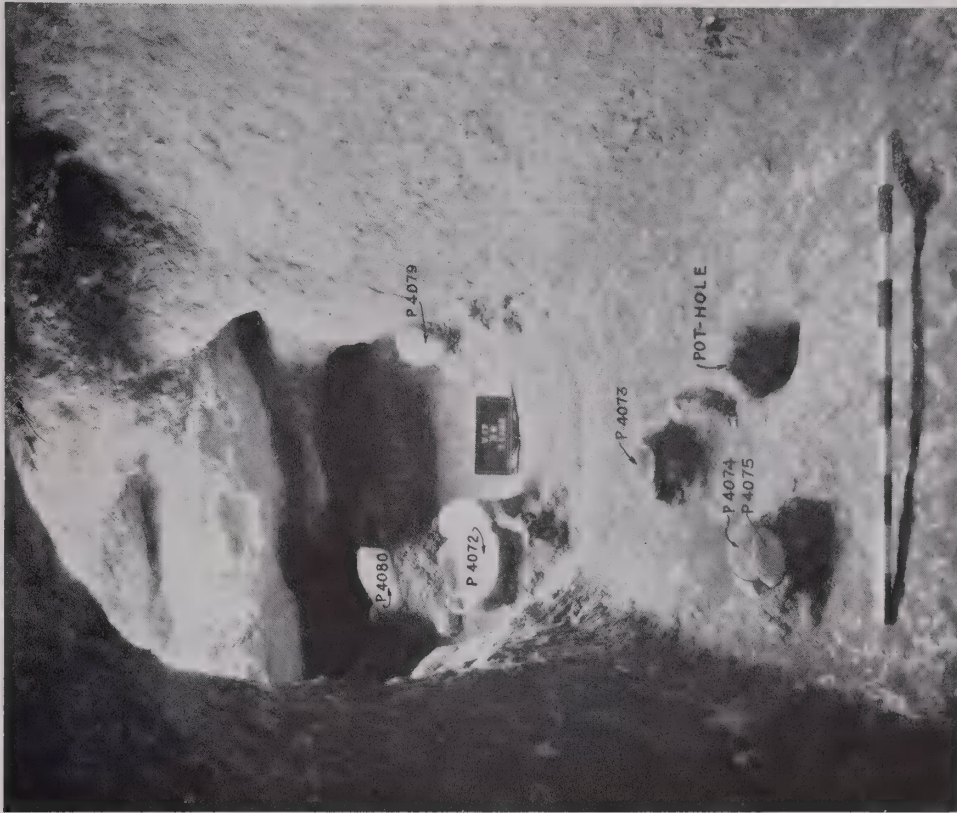

FIG. 17.—TOMB 1122 FROM NORTH, WITH LB II POTTERY



FIG. 16.—TOMB 1103 FROM EAST, WITH PART OF SKELETAL REMAINS EXPOSED

rock (see Pl. 2), and a third hole (in locus 1123) was large enough to have helped with ventilation.

Potsherds found on the floor show that there was occupation during Stages IV–VII, and the pot-hole visible in Figure 17 indicates that this was domestic (cf. p. 22). Still during this early time, but presumably after the cave had ceased to be a dwelling, a burial represented by a few fragments of adult bones, three pots (Pl. 5:1–3), a limestone vessel (Pl. 83:5), and a flint implement (Pl. 83:6) was put in on a shelf of rock at the west side. The position of the skeleton could not be determined.

There was no evidence of further occupation until LB II, when two adults were buried near the south entrance. Here also the skeletons were very fragmentary and their positions could not be determined. The number of spindles and whorls found (see Pl. 84) suggests that one at least was a woman. Disturbance had taken place, and the group is probably incomplete.

#### TOMB 1128 IN SQUARE V 16

Tomb, Chalcolithic to EB (Stage IV); contents, Chalcolithic to EB (Stage IV) with intrusions  
Contents illustrated on Pls. 5 and 84

A rock-cut chamber, originally square, with entrance to the east (see Fig. 22). Although the entrance was damaged, it could be seen that it had been horizontal and not a shaft. In this it resembles T. 910 (see p. 12), from which it should be not far removed in age. It had been broken into on the north from T. 1102, probably for use as part of the dwelling represented by T. 1102 Lower during Stage 0–I. The gap had been partly filled by a wall of rubble. Though no floor could be distinguished in the T. 1128 filling, pottery found in it (Pl. 5:14–17) could belong to the T. 1102 Lower occupation, especially since P 4060 (Pl. 5:17) is apparently the rim of a jar (Pl. 7:11) from T. 1102 Lower. A hole had been made by tomb-robbers in the south wall of T. 1128, allowing access to chamber C of T. 1098, but this must have been later still.

Much disturbance had evidently taken place among the contents of the tomb (Fig. 18), and the group must be incomplete. From the few bones found it was possible to determine that there had been at least two adults and three small children. There was one bead (Pl. 84:19) with the bones and two others (Pl. 84:17–18) a little above them. The six pottery vessels found (Pl. 5:8–13) form a useful, homogeneous group which falls well into Stage IV.<sup>5</sup>

#### TOMB 9 IN SQUARE V 19

EB

Contents illustrated on Pl. 10

A rough circular pit, apparently rifled, which produced but one pottery vessel (Pl. 10:1), the only piece of Khirbet Kerak ware yet found at Megiddo.<sup>6</sup>

#### TOMB 52 IN SQUARE R 16

Tomb, date uncertain; contents, chiefly EB with some LB II and MI  
Contents illustrated on Pls. 6 and 85

T. 52 shows three definite and widely separated periods of occupation. The first was in EB, probably during Stages I–III. The others, with much more fragmentary remains, took place in LB II and MI. The pottery from the earliest occupation is of special interest since it adds several types (Pls. 6:1–2 and 85:2) not found in the EB strata at Megiddo. Due to general

<sup>5</sup> See SAOC No. 10, pp. 23 f.

<sup>6</sup> For the chronological position of this ware see G. Ernest Wright, *The Pottery of Palestine from the Earliest Times to the End of the Early Bronze Age* (American Schools of Oriental Research, Publications of the Jerusalem School, "Archaeology" I [New Haven, 1937]) Table of Related Deposits II.

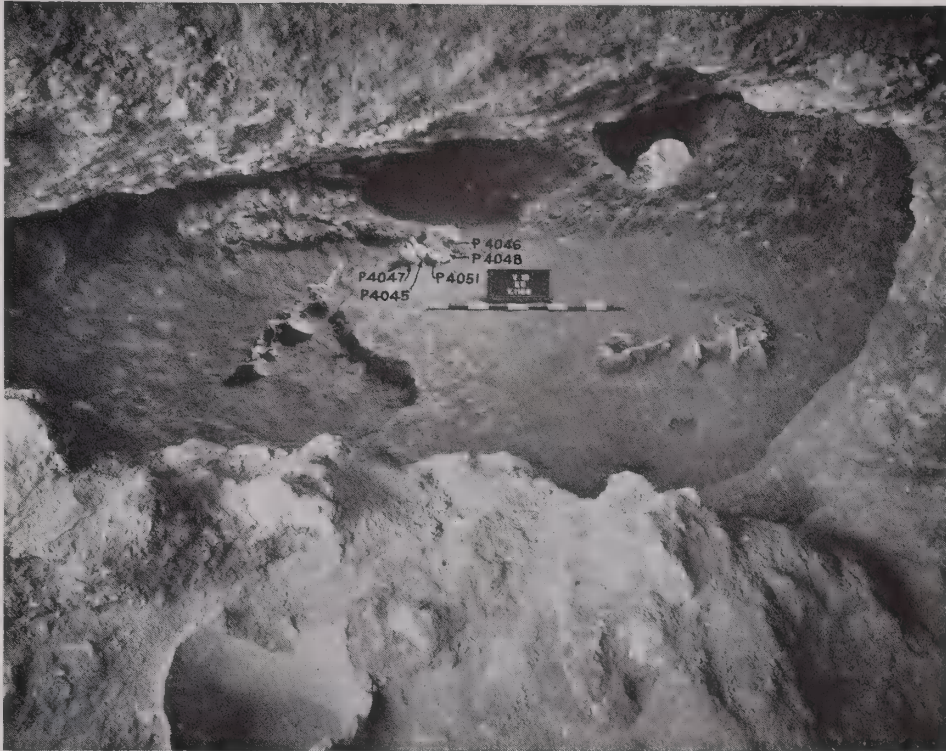

FIG. 18.—TOMB 1128, LOOKING SOUTH FROM TOMB 1102, SHOWING SKELETAL REMAINS AND POTTERY



FIG. 19.—TOMB 1106 FROM SOUTHWEST, SHOWING SKELETAL REMAINS AND WALL ACROSS FRONT OF CAVE

disturbance it is uncertain to which deposit a pottery star (Pl. 85:7) and a limestone whorl (Pl. 85:6) belong. A pottery wheel (Pl. 85:9) may be MI, and a pottery animal figurine (Pl. 85:8) is probably EB if we judge from its fabric.

#### TOMB 1106 IN SQUARE V 16

Tomb, date uncertain; contents, Chalcolithic (Stages IV–VII) and EB (Stages III–IV)  
Contents illustrated on Pl. 6

A cave in the rock with remains of a wall across its mouth and a grain pit or cistern which broke into the cave on the southeast (Fig. 19; see also Fig. 22). Level with the base of the wall were the remains of eight skeletons thoroughly disturbed and scattered. The pottery found with them (Pl. 6:8–14), although three pieces are doubtful, gives an average of Stages III–IV as a fair classification.



FIG. 20.—BOWLS OF GRAY BURNISHED WARE (P 4488 ABOVE P 4489) AS FOUND IN POT-HOLE IN TOMB 1106. SCALE, 1:5

There were interesting traces of domestic occupation on the rock floor underneath. In it were two depressions of the type commonly called “cupmarks.” One had a maximum diameter of .45 at the top, narrowing to .28 lower down, and a depth of .50. The other had a top diameter of .55 and a depth of .26. Both were lined with white plaster made from local limestone and scarcely distinguishable from it, and both had a number of lumps of basalt 5 to 10 cm. in diameter set in the plaster at the bottom. Traces of ash were found in both, and in the deeper one were two bowls (Pl. 6:15–16), one on top of the other (Fig. 20). This discovery and numerous others of a similar nature elsewhere, particularly in cave 863 and T. 921, show that some such “cupmarks” are really cooking places and are better called “pot-holes.” The two bowls fall into Stages IV–VII. Many fragments of similar bowls were found in T. 903

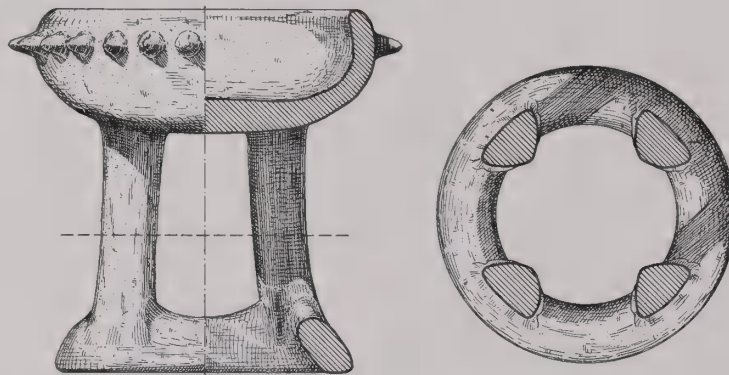

FIG. 21.—BASALT VESSEL (M 3647) FROM TOMB 1106 (HEIGHT RECONSTRUCTED). SCALE, 1:5

Lower. A basalt vessel from T. 1106 (Fig. 21) goes with the bowls, since the projections on it are duplicated by projections occurring on pottery bowls from T. 903 Lower (Pl. 3:31–32) which are of the same ware.<sup>7</sup>

Although the skeletons were found with the upper pottery, it is possible that they are to be directly associated with the pot-holes and the bowls found in one of them and were originally buried immediately over these, like the child's skeleton in T. 1101 A Lower (see p. 24); but their disturbance was so thorough that this could not be determined.

<sup>7</sup> Called “gray burnished ware.” See SAOC No. 10, pp. 61 f.

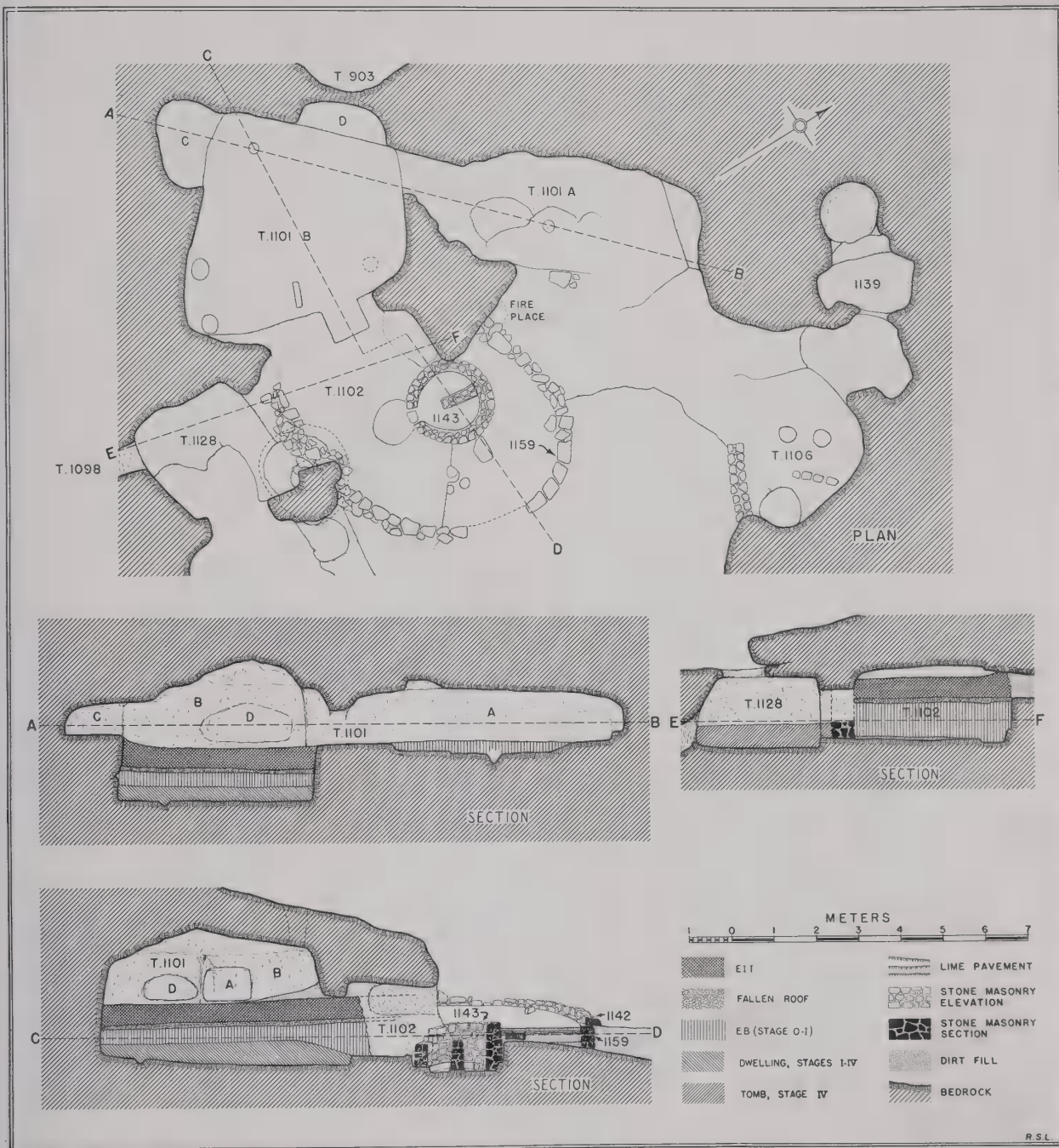

FIG. 22.—PLAN AND SECTIONS OF TOMBS 1101-2, 1106, AND 1128. SCALE, 1:150

## TOMB 1101+TOMB 1102 IN SQUARE V 16

Chiefly EB (Stage 0-I) and EI I

Contents illustrated on Pls. 6-9 and 85-87

Part of an elaborate complex of underground chambers (Fig. 22) which had several occupations, not all funerary.

As the clearance of T. 1101 A advanced, the EI I vessels described as belonging to T. 1101 A Upper (see Pls. 8 and 87) were found scattered on and just above the rock floor. Sherds of one vessel (Pl. 8:1) were separated by nearly three meters (Fig. 23). Other fragments of this interesting vessel were carefully searched for, but none could be found. No human remains accompanied these articles. In the rock floor was a pot-hole or cooking place (see Fig. 22) similar to those in T. 1106 (see above), in the base of which were inserts of basalt not unusual

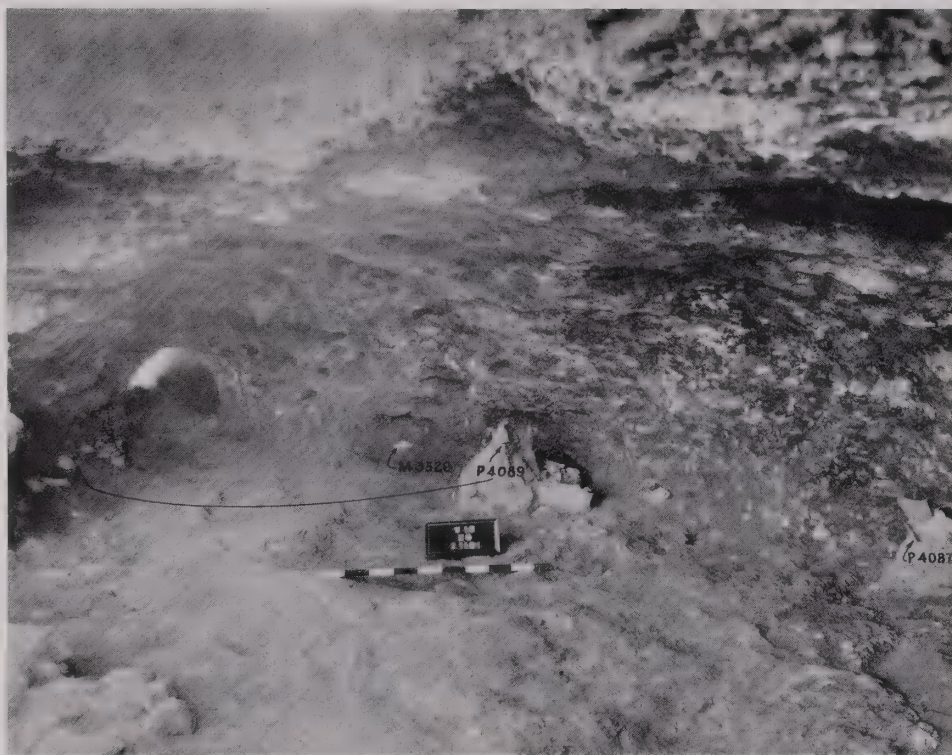

FIG. 23.—TOMB 1101 A, LOOKING SOUTHWEST INTO CHAMBER B, SHOWING EI I OBJECTS

in such places. Directly over the pot-hole, which contained ashes, lay the much decayed skeleton of a child about twelve years old, fully contracted on right side with head to east-northeast. Although one vessel (Pl. 6:17) limits the pottery found near the skeleton to Stage 0-I, it is hard to believe that the occupation to which the pot-hole belonged was not contemporary with that of T. 1106 next door (see Fig. 22), which is placed in Stages IV-VII because of bowls of gray burnished ware found in a pot-hole there. Thus, if the child burial in T. 1101 A belongs to the pot-hole over which it was found and marks the end of the occupation to which that pot-hole belonged, Stage IV seems a fairly probable period for the burial, and the Stage 0-I pottery (Pl. 6:17-19) found near it must mark a later use of the cave. Still earlier burials similarly situated, that is, immediately over a fireplace, have been found at other sites. A near-by example is a Natufian burial discovered by Miss Garrod at Mugharet el-Wadi, on the other side of Carmel.<sup>8</sup>

<sup>8</sup> *JRAI* LXII (1932) 260.

There was a fireplace or hearth on the floor of T. 1101 A in the angle between wall 1159 and the rock. A slab of basalt (.55×.40×.09) was set in the floor about a meter to the north of it (see Fig. 22) in the manner customary in dwellings of the Chalcolithic period. Such slabs seem to have been for use in the preparation of food, particularly perhaps bread.



FIG. 24.—TOMB 1101, SHOWING STRATIFICATION AND E II POTTERY IN WEST CORNER OF CHAMBER B. SEE FIG. 25 FOR ANOTHER FRAGMENT OF P 4119

T. 1101 A led into T. 1101 B, a spacious rock-cut chamber. The northwest part was filled with débris up to the height (1.3) of the floor of A. Elsewhere the débris rose in a cone toward the east corner of the roof, through which it had come by way of a hole, probably a chimney (dotted in Fig. 22). Though the earth of the cone and the flat deposit immediately under it are represented differently in the sections in Figure 22, there was actually little difference between them, and both had accumulated after the fall of the roof as shown in Figure 24. The pottery

from T. 1101 B Upper (see Pls. 8 and 87) overlay the fallen roof and underlay the intrusive upper earth. It was scattered and had some human bones with it as well as an iron dagger blade (Pl. 87:5), which must have been purposely bent or "killed" (see p. 137).

T. 1101 C was a recess in chamber B situated above the level of the filling. It was long enough to contain a full-length burial. It produced a few human bones and some EI I pottery (see Pls. 8-9 and 87), the latter overflowing into chamber B (see Fig. 24). T. 1101 D, a recess at the same height as C, contained only a few small fragments of bone but has been attributed to EI I in view of its similarity to C.

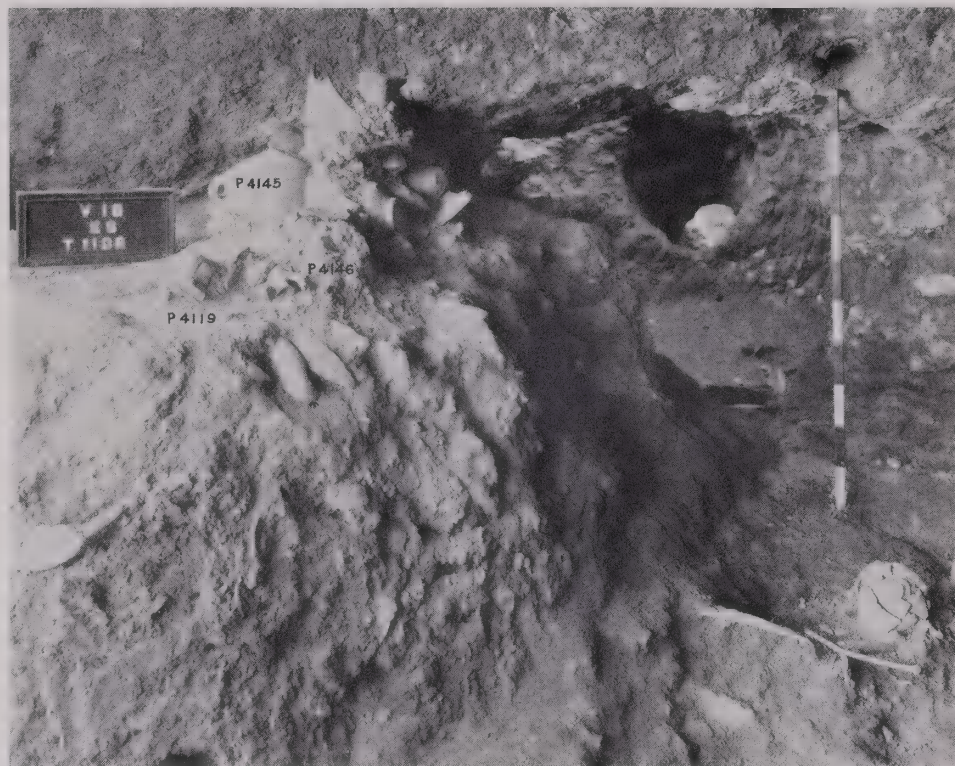

FIG. 25.—TOMB 1102 FROM NORTH-NORTHEAST, SHOWING EI I POTTERY. SEE FIG. 24 FOR ANOTHER FRAGMENT OF P 4119. THE SKELETAL REMAINS IN THE LOWER RIGHT-HAND CORNER BELONG TO TOMB 1101 B LOWER (CF. FIG. 26). TOMBS 1128 AND 1098 CAN BE SEEN IN THE BACKGROUND

The first discovery in T. 1102 was a collection of EI I pottery (Fig. 25). One sherd, P 4119, fitted onto a sherd from T. 1101 C (see Fig. 24), over seven meters distant, and it is probable that the whole collection came from there. As the upper filling and the EI I remains were removed from T. 1101 B and T. 1102 and the fallen roof was taken away, it became evident that these two loci were connected (Fig. 26). They were found to contain the remains of fourteen individuals (e.g. Figs. 193-94), in disorder but with some bones still showing articulation. The pottery which accompanied them (T. 1101 B Lower and T. 1102 Lower; see Pls. 6-7) places the burials in EB (Stage 0-I).<sup>9</sup> There was a considerable quantity of charcoal mixed with the deposit, and a number of bones bore signs of burning, generally on the upper surface only, showing that a fire had taken place not only after burial but after the disturbance which was so evident. The fire had not extended over the whole of the chambers but had been limited

<sup>9</sup> See SAOC No. 10, p. 58.

to the junction between them, where the bones were thickest. Under the bone deposit in T. 1101 B Lower were some 50 cm. of more or less stratified filling which contained ash and charcoal, with potsherds and fragments of animal bones, and represented a domestic occupation going back perhaps as far as Stage IV but no farther.

The history of the place is, then, as follows. First there was a domestic occupation in T. 1101 A during Stages IV–VII, which was terminated by a child burial over a pot-hole. T. 1106 probably had a similar history, and T. 1102, a shallow cave at that time, may also have been in use. The cutting of T. 1101 B and a break through into T. 1128 took place somewhat later than Stage IV. Wall 1159 and a kiln (1143) are at least that early and may be earlier.



FIG. 26.—TOMB 1101 B LOWER, LOOKING SOUTHEAST INTO TOMB 1102

All these loci, as well as T. 1101 A which was not yet connected with T. 1101 B, were occupied domestically down to Stage 0–I, when the skeletons were introduced into T. 1101 B and T. 1102. Whether these were properly buried or not is problematical; they may even have been brought from elsewhere. After the deposit of the skeletons there was a long period of disuse followed by the breaking through from A to B and the cutting of recesses C and D during EI I. These last were subsequently looted.

#### TOMB 7 IN SQUARE W 19

##### MB I

A well cut shaft tomb of normal type (see pp. 136 f.), which yielded a few characteristic MB I sherds (not illustrated). Originally T. 7 had nothing to do with T. 15–16 (see Pl. 1), but by continuous enlargement of the latter two all were finally brought into one system.

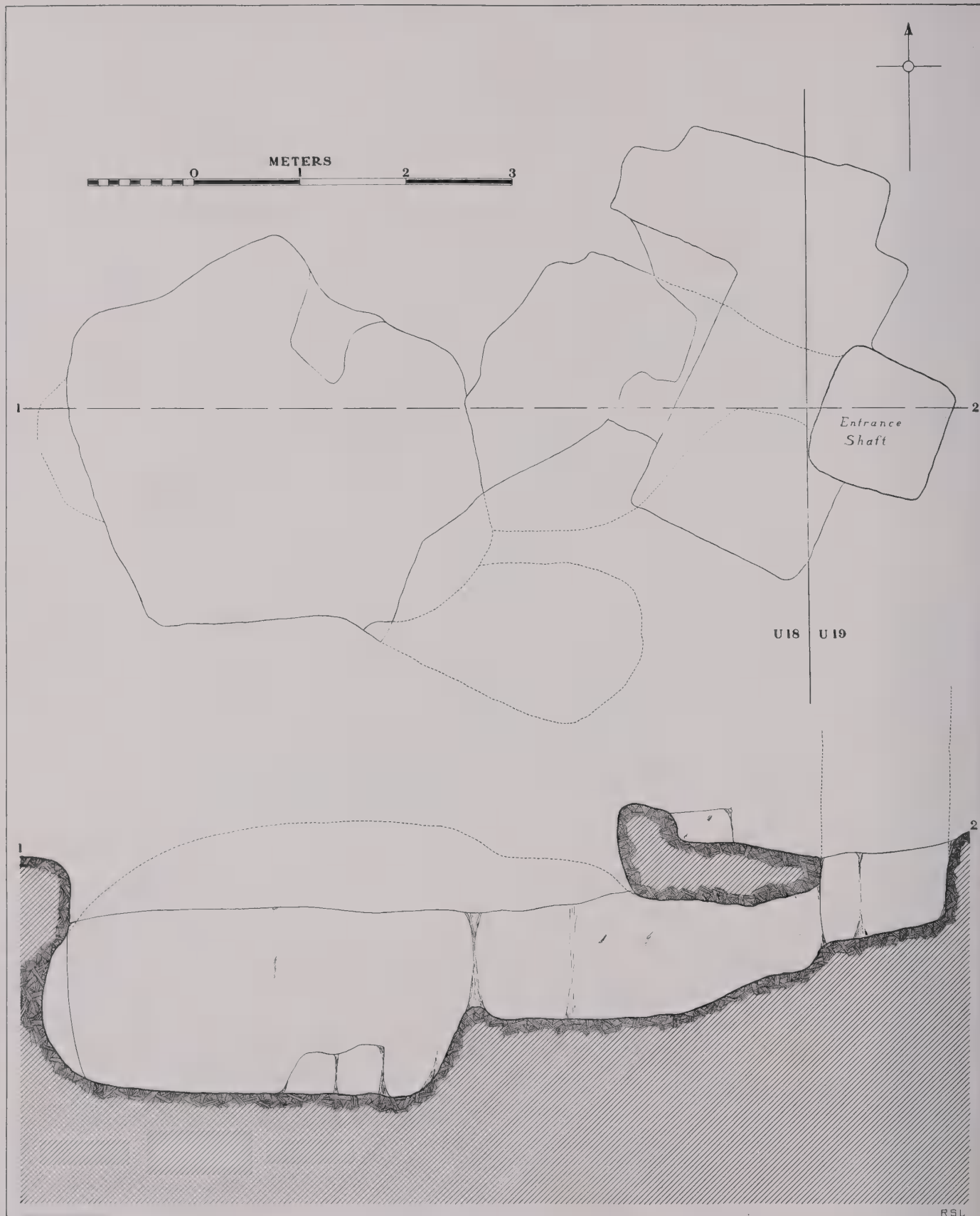

FIG. 27.—PLAN AND SECTION OF TOMB 41. SCALE, 1:50

## TOMB 15 IN SQUARE W 19

Tomb, MB I?

A large cave with entrance probably at the southeast (see Pl. 1). During a late enlarging it was connected with the shaft of T. 7. Danger of rock collapse stopped excavation before anything was found. The only basis for dating is proximity to T. 7 and T. 16.

## TOMB 16 IN SQUARE W 19

MB I

A greatly damaged cave with entrance probably to the southeast (see Pl. 1). A connection with T. 7 was broken through late in its history. Due to danger of rock collapse work was stopped before excavation could be completed. The MB I pottery found<sup>10</sup> is practically duplicated by some from T. 41 and is therefore not illustrated in this volume. Jars with both flat and round base and fully folded ledge handles (cf. Pl. 10:9-10) as well as small lug-handled jars (cf. Pl. 10:7) occurred.

## TOMB 41 IN SQUARES U 18-19

Tomb, MB I; contents, MB I with some EI I

Contents illustrated on Pls. 10 and 88

A shaft tomb with only three chambers, all extremely irregular and much larger than usual (cf. Fig. 168). The top of the shaft is shown in Figure 83. An EI I bowl (not illustrated) may represent a reuse of the tomb before roof collapse and quarrying (see p. 110) reduced it to the state seen in Figure 27. The MB I pottery is usual except for a "teapot" (Pl. 10:5), probably imported from Syria (see p. 36), which is unique at Megiddo. It is not certain to which deposit a flint and an unfinished pottery whorl (Pl. 88:8-9) belong.

## TOMB 58 IN SQUARES T 18-19

MB I

Contents illustrated on Pl. 88

An abnormal shaft tomb (Fig. 28), dated by pottery as well as by the rectangular form of the shaft to the MB I period. There was only one chamber (possibly two originally; see projections at north end), and its entrance was considerably lower than the bottom of the shaft. The floor of the chamber itself was still lower. The contents were not *in situ*.

## TOMB 67 IN SQUARE U 18

Tomb, MB I; contents, MB I with intrusions

Contents illustrated on Pls. 10 and 88

Originally a shaft tomb, but quarrying (see p. 110) had almost completely destroyed its outline (Fig. 29), and no reliable plan could be made. There had been much disturbance, and no skeletal remains were found. Some of the pottery (Pl. 10:11-13) is typical of the MB I burials found in shaft tombs and undoubtedly belongs to the tomb group. P 22 (Pl. 10:14) is an odd type of jug which we cannot place definitely. It is even difficult to say whether it is hand- or wheelmade, and it is doubtful whether it belonged to the tomb group. No. 3995 (Pl. 10:15) is too late to belong to the tomb group.

## TOMB 79 IN SQUARE T 17

MB I?

A shaft tomb with a single small chamber. The shaft was 2.0 deep and 1.0 square with recessed footholds in the sides. At the foot of the shaft on the west side was a doorway

<sup>10</sup> Illustrated in *OIC* No. 4, Fig. 33.

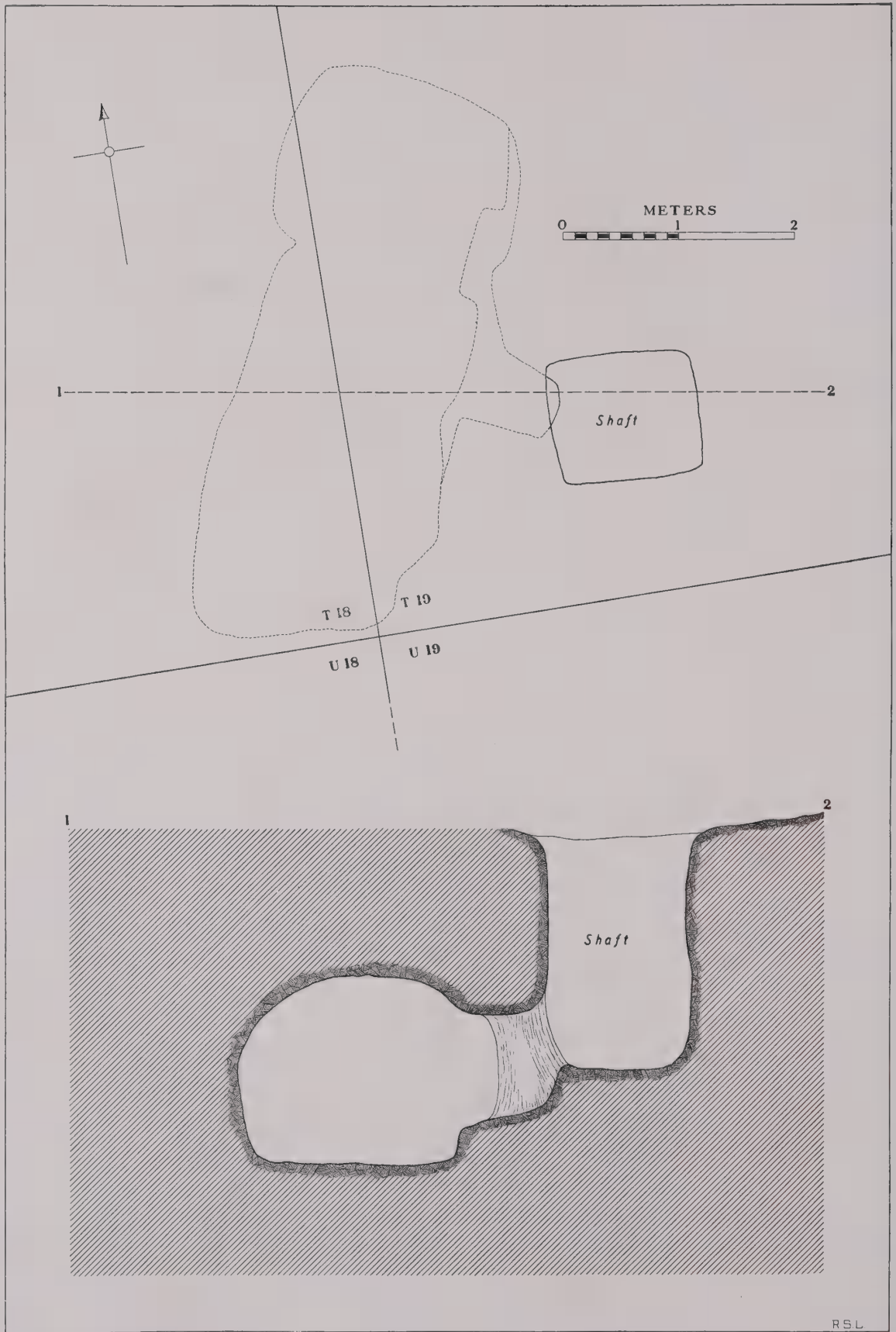

FIG. 28.—PLAN AND SECTION OF TOMB 58. SCALE, 1:50

RSL

(.7 high  $\times$  .5 wide) into the roughly circular chamber (1.25 in diameter and 1.2 high). No tool marks were visible.

It is possible that this was an unfinished tomb and that the original intention had been to make a normal shaft tomb. The fact that nothing was found in it lends color to this view. If it is to be regarded as a finished tomb, it may be concluded that because of its size whatever burials it may have contained were contracted.



FIG. 29.—TOMBS 66-67 AND 70 FROM SOUTHEAST, SHOWING TRACES OF THE QUARRYING WHICH DAMAGED THEM

#### TOMB 217 IN SQUARES U 17-18

Tomb, MB I; contents, mixed

Contents illustrated on Pls. 10-11 and 89-91

An abnormal shaft tomb (Fig. 30). The degree of destruction is shown in Figure 31, where results of quarrying (see p. 110) can be seen at many points. The contents had been much disturbed, and the groups cannot be said to be complete. Only a few fragments of human bones were found.

Chamber A produced no pottery except sherds (not illustrated) which were too fragmentary to give forms and too mixed to give a period. The finding of all the other objects (Pls. 89-90) together suggests that they form a group.

Chamber B produced a homogeneous group of MB I pottery (see Pls. 10 and 90), with the exception of an intrusive Chalcolithic jug spout (Pl. 10:22).

The pottery from chamber C (see Pls. 11 and 91) seems to represent two burials, LB I and LB II.

Chamber D produced only mixed sherds (not illustrated), some as late as MI.

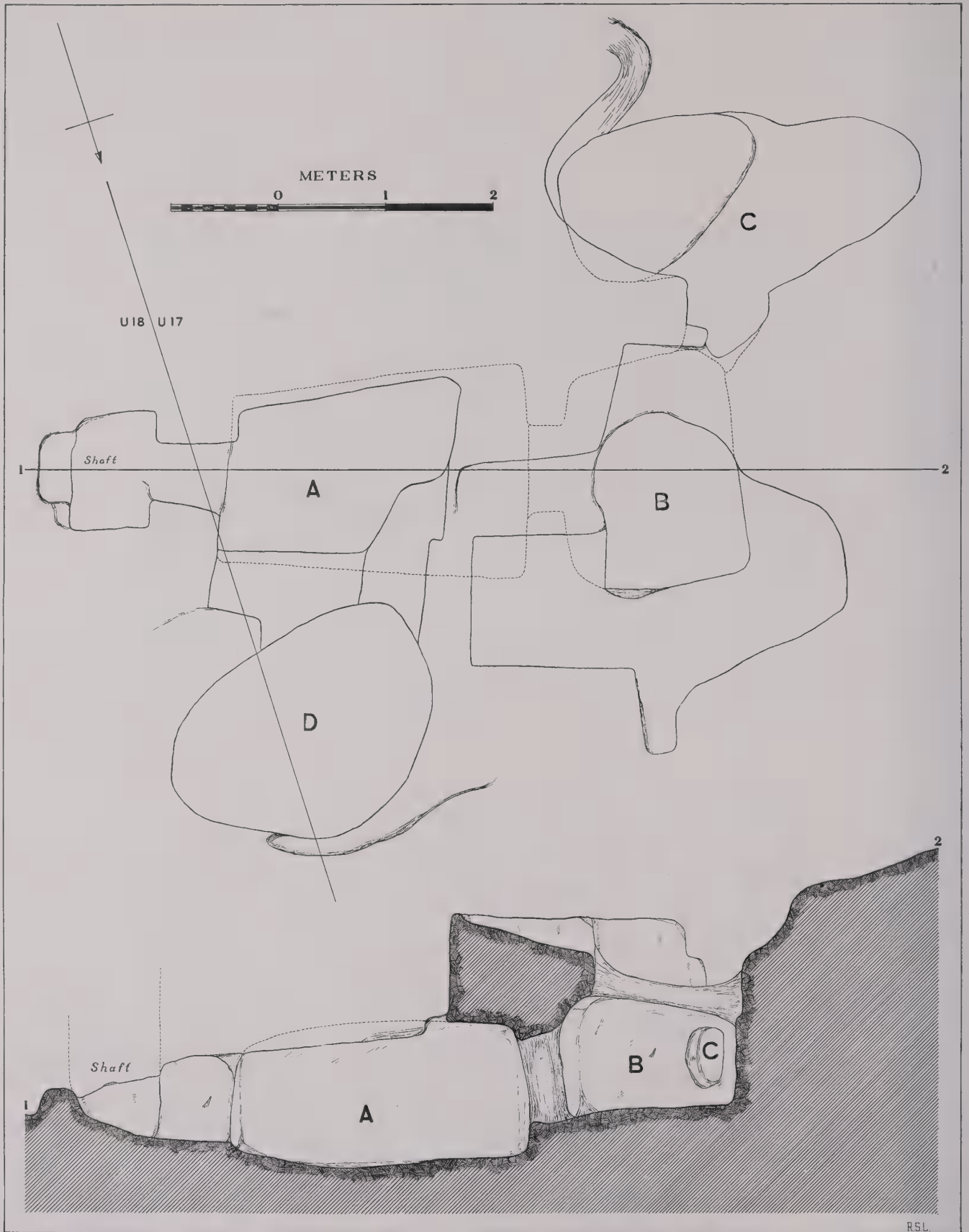

FIG. 30.—PLAN AND SECTION OF TOMB 217. SCALE, 1:50



FIG. 31.—TOMB 217 FROM EAST, SHOWING EFFECTS OF QUARRYING

#### TOMB 877 IN SQUARE W 16

Tomb, MB I; contents, MB I and LB

Contents illustrated on Pls. 11-14 and 91-96

An abnormal shaft tomb. Part of the east side of the shaft had been quarried away (see p. 110). What remained contained earth and stones, with some lime, all of which are to be regarded as intrusive because the blocking stone at the entrance, a roughly spherical block (.85 × .95), was found out of place at the bottom. There were footholds, both projecting and recessed, in the shaft. All the chambers contained a great deal of earth which had filtered in and rock which had fallen from the roof. The abnormality of the plan (Fig. 32) was due to the proximity of T. 989, which must already have been in existence when T. 877 was cut. The makers of the latter broke into T. 989 C when they were squaring off the southwest corner of their own chamber A and found that it was impossible to make the usual chambers on the south and west. The making of chamber B (in the position of C in a normal tomb; cf. Fig. 168) presented no difficulties, and since more room was wanted, an extra chamber (C) was made on the east of it. Chamber C originally had the usual narrow entrance, but this had been enlarged later, as had the entrance from A to B. All the walls were roughly finished, without plaster. They contained numerous holes (.04-.06 in diameter and .2-.3 deep), some near the floor and some near the roof (see p. 137). Nothing was found in any of them. Skeletal remains were few and fragmentary.

Chamber A contained remains of two periods, MB I (T. 877 A 2) and LB II (T. 877 A 1), separated by some 30 cm. of sterile filling partly waterlaid (Fig. 33). Figure 34 shows the MB I burial after removal of the LB II furniture (except P 2926) and the sterile earth and gives a good idea of the disturbed state of the bones and pottery. Two fragments of "teapot" P 2931 (Pl. 11:35) lay about a meter apart, and part of its rim was found in chamber C (see Figs. 34 and 37). The disturbance of this burial must have taken place before the sterile earth was laid down, for that was intact and no later sherds were found below it.

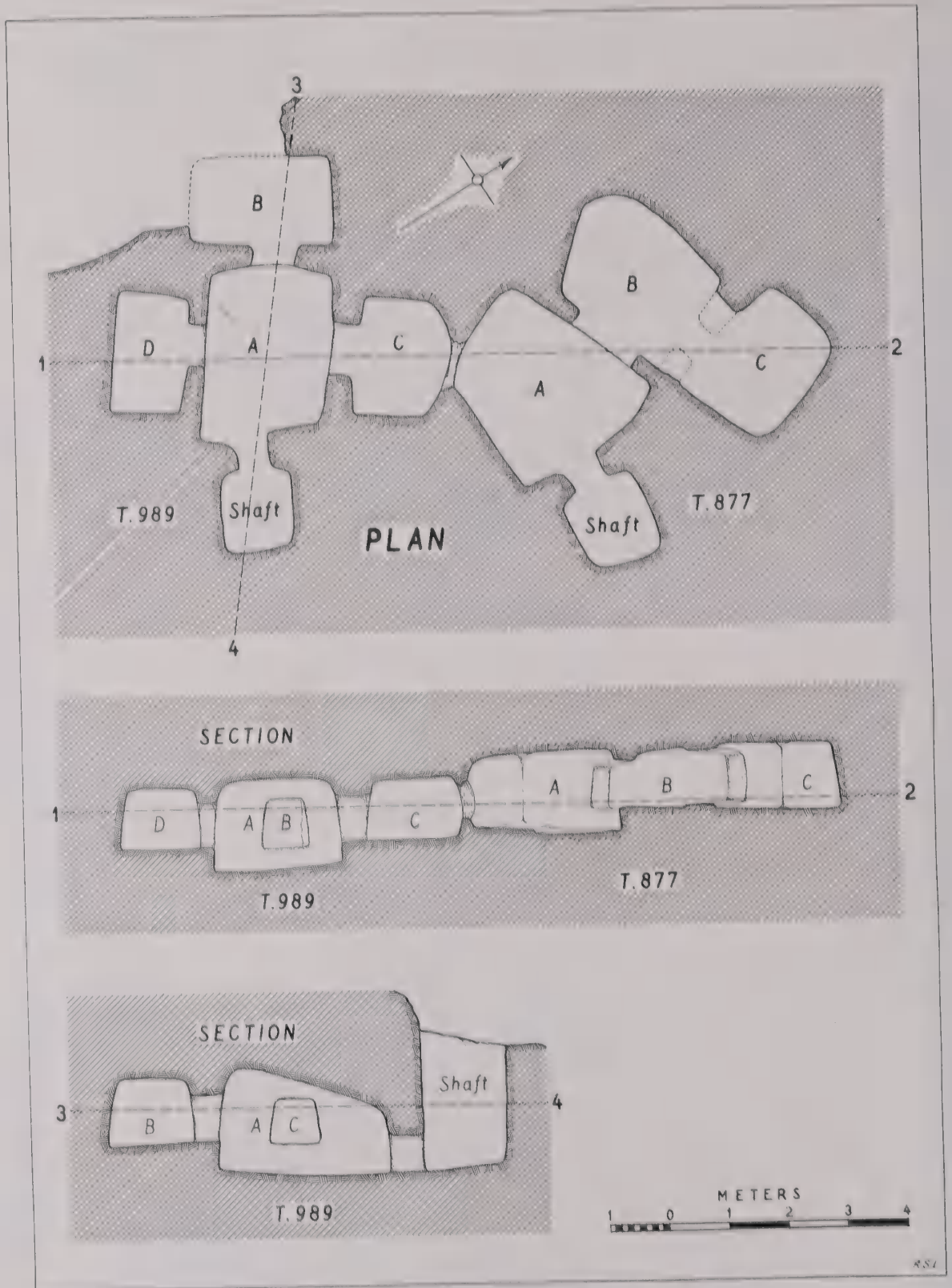

FIG. 32. PLAN AND SECTIONS OF TOMBS 877 AND 989. SCALE, 1:100



FIG. 33.—TOMB 877 A, LOOKING WEST FROM ENTRANCE, SHOWING LB II POTTERY SEPARATED BY STERILE EARTH FROM MB I POTTERY



FIG. 34.—TOMB 877 A AFTER REMOVAL OF LB II POTTERY (EXCEPT P 2926), LOOKING WEST FROM ENTRANCE

Chamber B also contained MB I (T. 877 B 2) and LB II (T. 877 B 1) remains (Figs. 35–37). The remains of the two periods were much closer together in depth here than in A. Disturbance and confusion were general, even the beads being scattered. One or two adult long bones along the north wall, with LB II pottery (see Fig. 35), suggest that one burial had been at full length.

Chamber C (see Fig. 37) also showed confusion, the extent of which is indicated by the fact that a sherd found there fitted onto a milk bowl (Pl. 19:15) found in T. 989 C. But the chamber C vessels illustrated on Plate 12 make it clear that this chamber also had first been used during MB I. The pottery of that period was mixed with LB I and LB II pottery (see Pl. 14). So far as could be made out it seemed that there actually had been a LB I burial in C, but no LB II burial, and that therefore the LB II vessels found in C (see Pl. 14) really belonged to

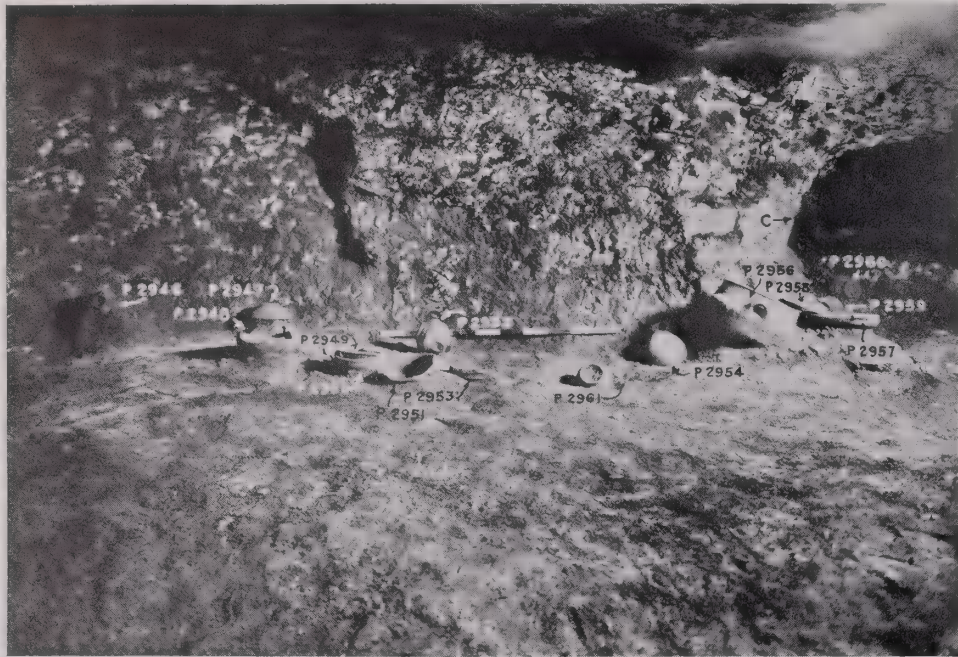

FIG. 35.—TOMB 877 B AND PART OF C FROM SOUTH, SHOWING LB II POTTERY AND TWO MB I "TEAPOTS" (P 2960–61)

the LB II burial in B. Some of the other objects from C (see Pl. 96) may also be associated with the latter.

T. 877 furnishes an excellent collection of MB I pottery (see Pls. 11–12), which forms a type group for the period, the degenerate jar P 2928 (Pl. 12:6) with its folded ledge handles marking the end of a long line of finer vessels of this sort which had endured through the Chalcolithic and EB periods (see p. 148). "Teapots" P 2935–36 (Pl. 12:3 and 1) belong to the same group and period, though one is handmade and the other wheelmade. "Teapots" are characteristic of shaft tombs, and commonly the handmade and the wheelmade varieties occur together. The explanation of this is probably that the wheelmade vessels were imported from a country, probably Syria (see p. 148), more advanced in the potter's craft and that the handmade were local copies in the native technique, retaining local characteristics of rim and base.

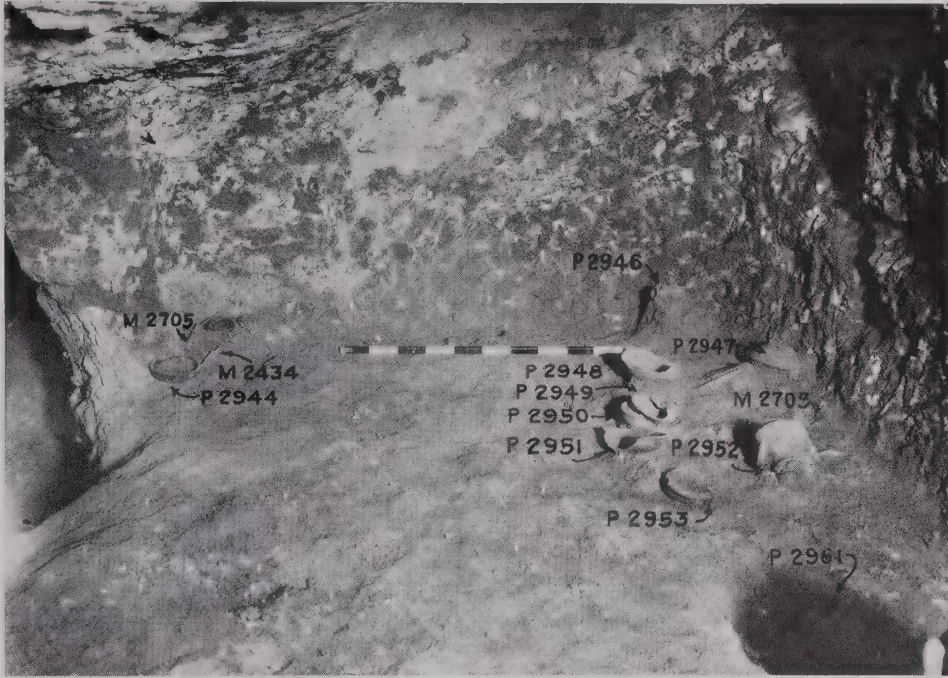

FIG. 36.—TOMB 877 B FROM NORTHEAST, SHOWING LB II OBJECTS AND A MB I "TEAPOT" (P 2961)

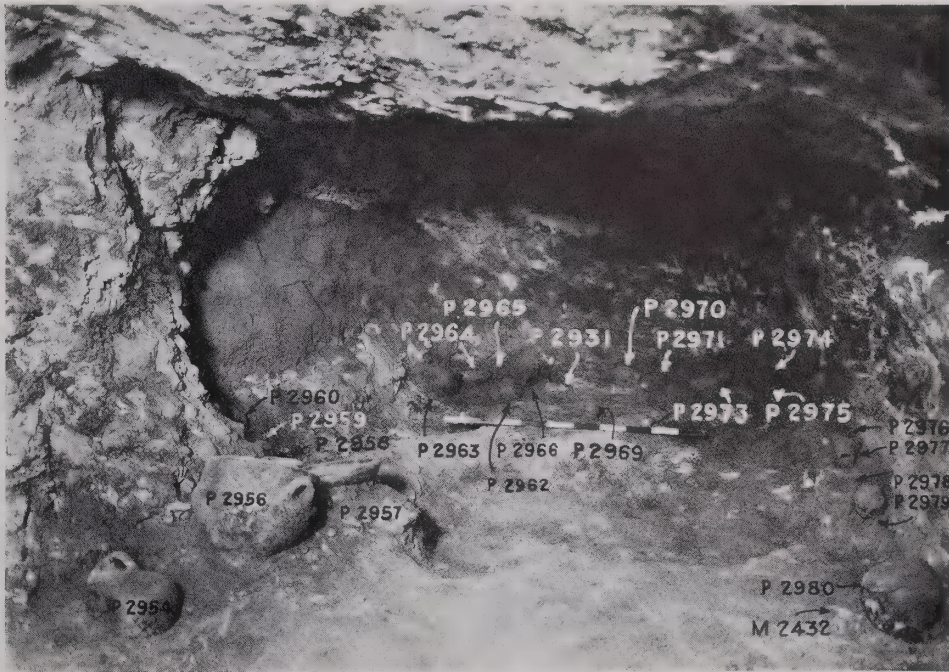

FIG. 37.—TOMB 877 B, LOOKING NORTHEAST INTO CHAMBER C

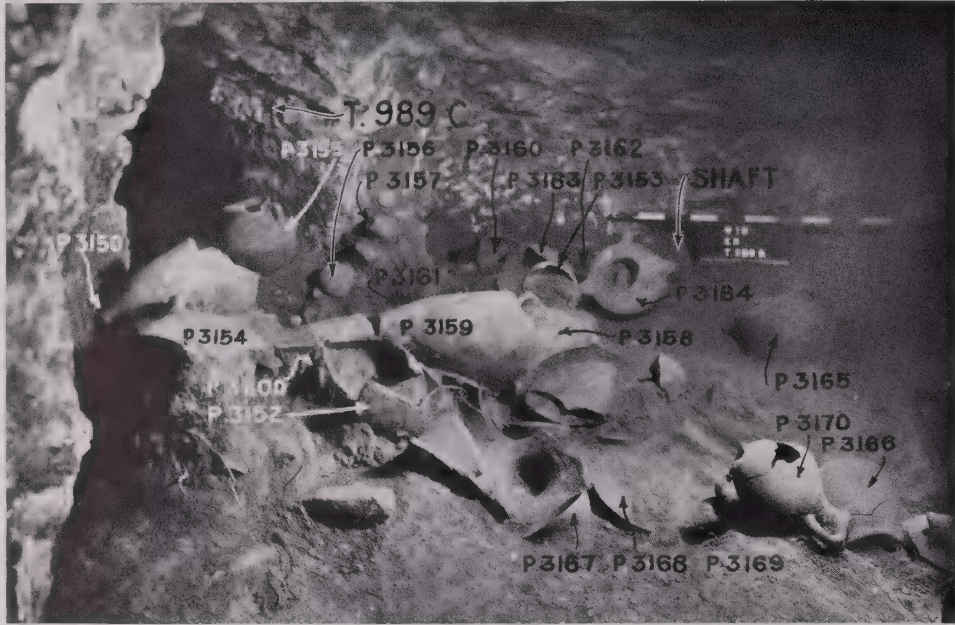

FIG. 38.—TOMB 989 A FROM WEST-NORTHWEST, SHOWING LB II POTTERY

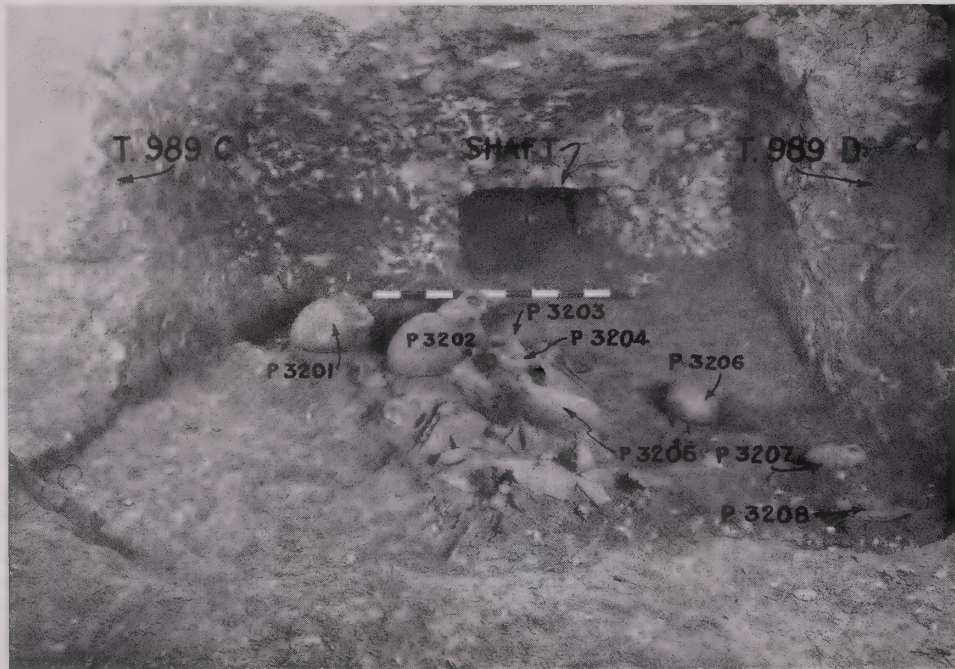

FIG. 39.—TOMB 989 A FROM NORTHWEST, SHOWING LB II POTTERY FOUND AFTER REMOVAL OF THAT SHOWN IN FIG. 38

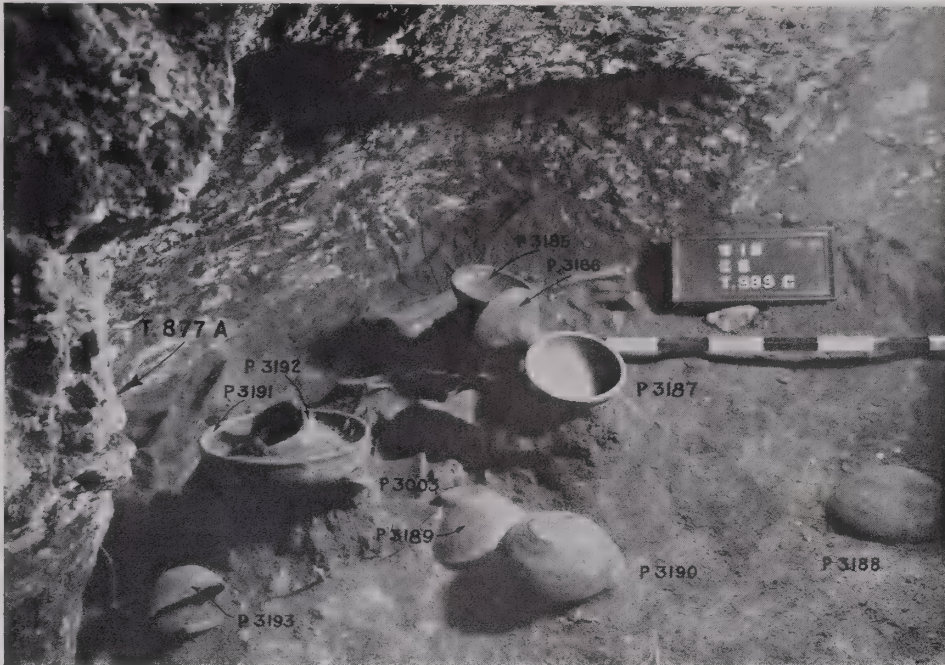

FIG. 40.—TOMB 989 C FROM NORTHWEST, SHOWING LB II POTTERY



FIG. 41.—TOMB 989 C FROM NORTHEAST, SHOWING LB II POTTERY

## TOMB 989 IN SQUARES W 15-16

Tomb, MB I; contents, MB I and LB  
 Contents illustrated on Pls. 15-20 and 97-101

A normal shaft tomb (see Fig. 32). The rock of the walls was considerably weathered in most places, and a good deal had fallen from the roof. The workmanship had probably been rough in the first place, since no traces of plaster or whitewash could be seen. There were two holes in the walls (see p. 137), one near the roof and the other near the floor of chamber C. The whole tomb was full of *débris*, and there was great confusion and breakage among the furniture as well as among the human skeletal remains, neither the original position nor the number of which could be ascertained. Some animal bones occurred in every chamber, but whether they represented offerings or were intrusive is hard to say. The filling and confusion are easily accounted for by the fact that most of the roof of chamber B and part of that of D had been quarried away (see p. 110). In addition, chamber C and T. 877 A were connected (see Figs. 32-34), and part of a milk bowl (Pl. 19:15) from chamber C was found in T. 877 C.

In all the chambers the pottery showed that there had been two occupations, one during MB I and the other, which in the case of chamber C is dated by a scarab (Pl. 100:5) to the reign of Ramses II, during LB II (Figs. 38-41). In addition to the furniture of these two periods a few pieces of LB I pottery were found in each chamber. Several of these are almost certainly intrusive, for example two interesting fragments from A (Pl. 16:11-12) which are of the same type as a fine jug (Pls. 48:3 and 147:6) from T. 1100 C. The beads, scarabs, and spindles (Pl. 100) were found in the vicinity of jar P 3003 (cf. Fig. 40).

## TOMB 878 IN SQUARE W 16

Tomb, MB I; contents, MB I with intrusions  
 Contents illustrated on Pls. 20 and 101

A normal shaft tomb (Fig. 42). The shaft had one projecting and one recessed foothold. It was full of earth containing a few fragments of pottery and bone. Tomb-robbers had probably entered by means of the shaft, since the blocking stone was found displaced. There was a notable case of ancient disturbance, a sherd of "teapot" P 3552 (Pl. 20:13) being found in chamber A of T. 911 in square V 17 (see Pl. 2). Traces of a ridge of plaster round the rim of the shaft suggested that it had been plastered over for concealment after the burial.

Chamber A was about three-quarters filled with earth containing pottery, all MB I except an intrusive Cypriote milk bowl sherd (not illustrated) with fragments of animal bones in it, a few flints (not illustrated), and some human bones. In the northwest corner on a ledge were more bones and MB I pottery. There was no furniture in the other chambers except fragments of pottery (undatable) in B and C and a few beads in D (see Pl. 101), but human remains occurred in all the chambers. These were so much disturbed and so fragmentary that nothing could be learned of the original positions of the bodies. As far as could be ascertained they were distributed as follows: chamber A, 1 adult; chambers B and C, 1 adult and 1 child each; chamber D, 2 adults and 1 child.

## TOMB 880 IN SQUARE W 16

Tomb, MB I; contents, MB I with intrusions  
 Contents illustrated on Pl. 20

A shaft tomb. The slight abnormality of its plan (Fig. 43) was apparently due to the proximity of T. 884 on the north and to faults in the rock to the south. The shaft had a small step of rock in the south corner in addition to recessed footholds in the sides. The blocking stone

(.70×.60×.60) was found out of place at the bottom. The tomb had been broken into on three sides, and B had been almost completely destroyed by the cutting of the large cistern or silo 1112. The walls were much broken and weathered, but in places they retained their original surface, which was fairly good. The whole tomb was full of débris. Aside from numerous mixed sherds (not illustrated) a fairly complete MB I jug (Pl. 20:20) and only the smallest fragments of bone were found.

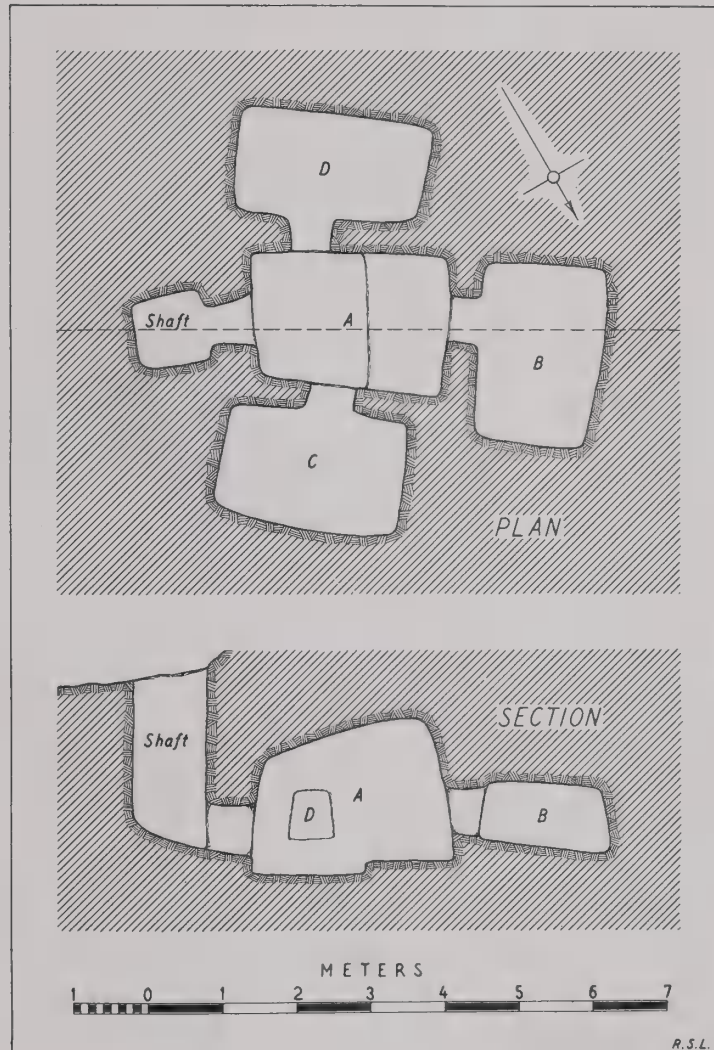

FIG. 42.—PLAN AND SECTION OF TOMB 878. SCALE, 1:100

#### TOMB 884 IN SQUARE V 16

Tomb, MB I; contents, chiefly MB I

Contents illustrated on Pls. 20–21 and 101

A normal shaft tomb (see Fig. 43), in which only chamber A had the roof intact. The other chambers had been extensively damaged by later rock cutting, C having practically no roof left, and all were consequently full of débris. The walls were much broken and weathered, but where they had been somewhat protected, as in A and the southwest part of B, there were

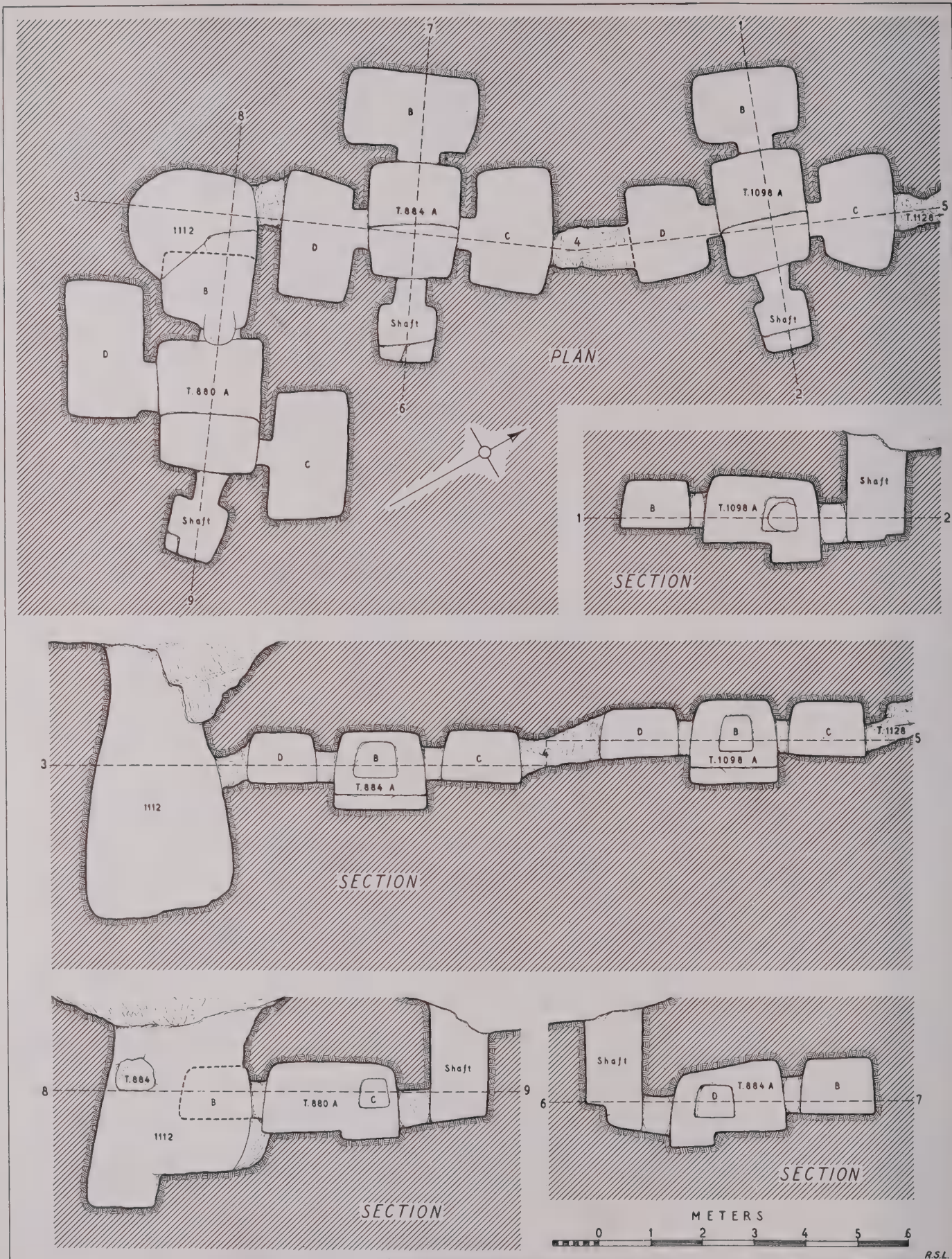

FIG. 43.—PLAN AND SECTIONS OF TOMBS 880, 884, AND 1098. SCALE, 1:100

traces of what appeared to be a layer of whitewash. A few holes were observed in the walls, but none of them contained anything (see p. 137).

The few pots found in C and D (Pl. 21:1-3) may quite well have fallen in with the débris and are thus suspect, but the group from A (see Pls. 20 and 101) obviously belonged to a MB I burial. Only a few fragments of bone were found with it.

TOMB 1098 IN SQUARE V 16

MB I

Contents illustrated on Pls. 21 and 101

A normal shaft tomb (see Fig. 43), which tomb-robbers had entered through chambers C and D. These and chamber B produced nothing but intrusive débris. The blocking stone was

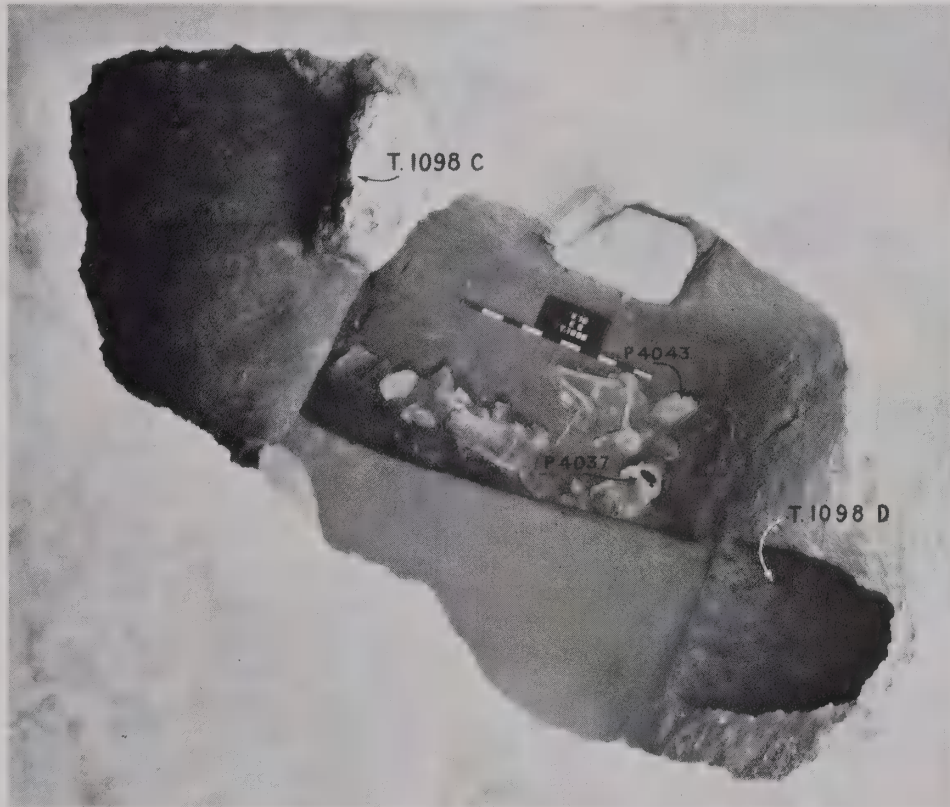

FIG. 44.—TOMB 1098, LOOKING THROUGH HOLE IN ROOF, SHOWING MB I BURIAL IN CHAMBER A. NOTE STONE BLOCKING IN THE ENTRANCE FROM THE SHAFT (ABOVE NUMBER PLATE)

found firmly wedged into the entrance, a fact which is of interest in view of the finding of MB I pottery in the shaft as well as in chamber A. The few holes in the walls of the chambers contained nothing.

Figure 44 shows all that remained of the burials in chamber A. These apparently escaped removal because they lay in the pit just inside the entrance, but they had been considerably disturbed. The bones of two adults and one adolescent were distinguishable.

TOMB 891 IN SQUARE V 16

MB I

Contents illustrated on Pls. 21 and 102

A normal shaft tomb (Fig. 45). The blocking stone (.5×.4) was found slightly out of place at the bottom of the shaft. The presence of nests of mason bees in chamber A showed that for

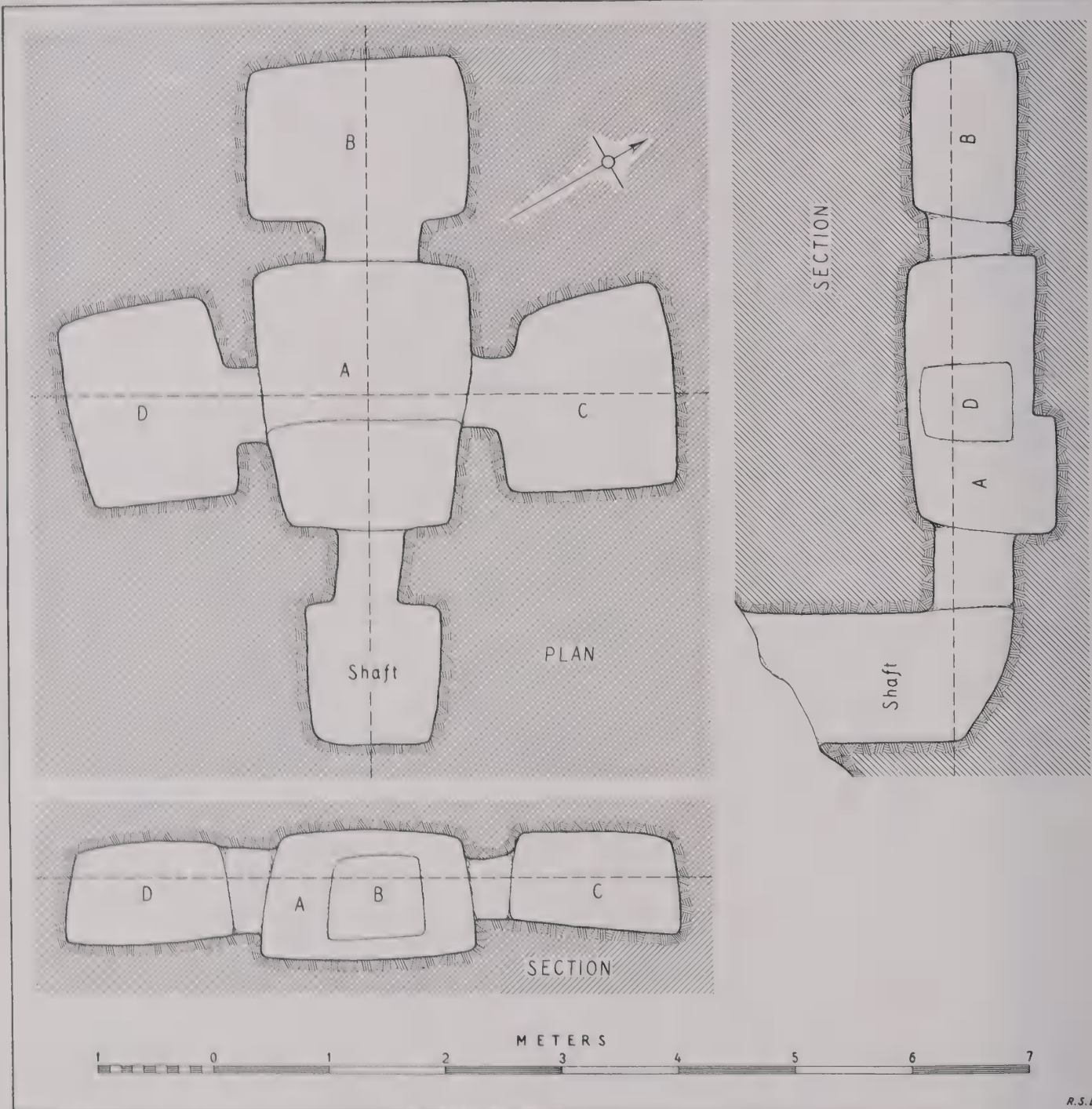

FIG. 45.—PLAN AND SECTIONS OF TOMB 891. SCALE, 1:50

some time after the stone had been displaced the shaft must have remained open, for there was no other means of access to the tomb. As a consequence, it was only in the pit in the floor of chamber A, just inside the entrance, that débris had accumulated to any extent, though the roof had fallen in several places. The walls of A, C, and D were whitewashed, and those of B were covered with a thin coating of light brown mud plaster.

Only chamber A contained pottery, all of which was MB I. Some lay on the floor and some in the pit in the floor. Fragments were missing from several vessels. There were a few scattered fragments of bone, both human and animal, on the floor, but no skulls; and the pit produced a few human remains, including three skull fragments which had probably belonged to two individuals.

In B there was the fairly complete but much decayed skeleton of an adult lying in a closely flexed position with its head in the doorway facing south. C contained only a few human bones, and D contained nothing.

## TOMB 913 IN SQUARE V 17

MB I

An unfinished tomb shaft, which broke into T. 910 F and was thereupon stopped by its makers. It is of interest as showing that shaft tombs are later than T. 910.

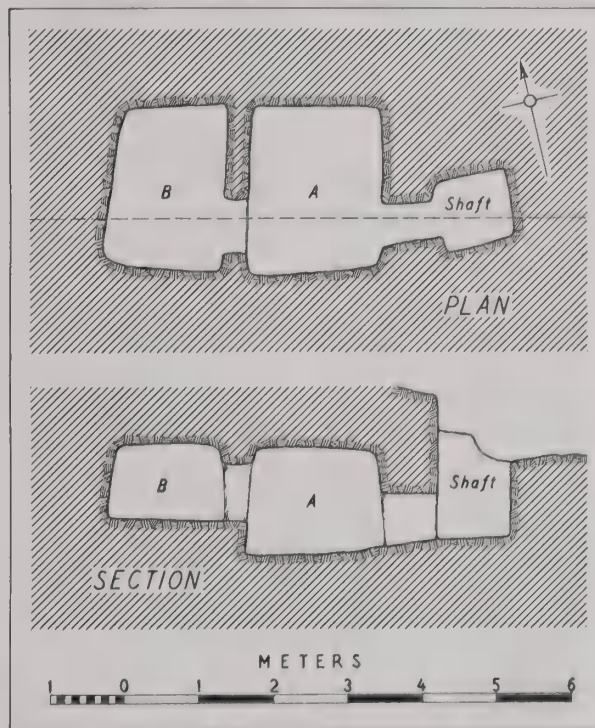

FIG. 46. PLAN AND SECTION OF TOMB 922. SCALE, 1:100

## TOMB 922 IN SQUARE V 17

MB I

Contents illustrated on Pls. 22 and 102

A shaft tomb with only two chambers, A and B (Fig. 46). There was no pottery in B, and A produced only two vessels (Pl. 22:1-2). An adult finger bone and the broken clavicle of a child were the only human remains in A; B contained a few adult toe bones and ribs.



FIG. 47.—PLAN AND SECTIONS OF TOMB 1014. SCALE, 1:50

## TOMB 1014 IN SQUARE V 16

MB I

Contents illustrated on Pls. 22 and 102

A shaft tomb originally of normal plan except that chamber D was smaller than usual (cf. Fig. 168). Chamber A' (Fig. 47) was the original chamber B. Later the partition between A and A' was removed, making one large chamber, and another chamber B was excavated.

Chamber A contained one arm bone as well as some MB I pottery (see Pl. 22), and chambers C and D produced nothing. In the middle of chamber B was a small pile of very decayed adult bones, on which rested two vessels, P 3611-12 (Pl. 22:8-9). Among the bones themselves were found a bone needle and two copper toggle pins (Pl. 102:7 and 9-10); a copper borer (Pl. 102:8) was found in a hole in the wall about halfway between floor and roof in the south corner of the chamber (see p. 137). The bones were too much decayed for their original position to be determined, but from the space occupied by the pile and the situation of pots on top of it it may be inferred that little if any disturbance had taken place and that the burial had been a contracted one.

## TOMB 1119 IN SQUARE V 16

MB I

An unfinished tomb shaft.

## TOMB 1120 IN SQUARE V 17

MB I

Contents illustrated on Pls. 22 and 102

An abnormal shaft tomb (Fig. 48). The shaft was rounded, with projecting footholds on the sides, and it stopped not far below the roof of the tomb. No blocking stone was found. The entrance was about the same size as that to a normal shaft tomb (cf. Fig. 168), but rather shapeless, and there were rough steps, partly rock cut and partly built of stones, leading down into the tomb itself. This was really a single chamber with four irregular recesses (B-E) round its sides. In the central part the floor had been dug rather deeper than elsewhere, and single stones had been set just inside the depression thus made so as to form inclosure A. A cone of earth extended for a short distance inside the entrance, and a good deal of roof had fallen into A, but otherwise the floor was almost free of debris. An odd find was that of several rough pieces of basalt lying on the floor, and one piece, about the size of a human head, had been jammed into a crevice in the rock. That the tomb had been entered in antiquity was shown by the presence of one or two potsherds lying on top of the fallen roof. The walls were for the most part rough and irregular, but this may have been due in part at least to the poor quality of the rock. The marks of fairly broad metal tools could be distinguished in places.

Only a few human bones remained in the tomb, being found chiefly in recess E. They were considerably decayed and had evidently been disturbed. The original position of the bodies could not be determined, and the number of individuals is uncertain.

The general irregularity of the tomb suggests that it is to be regarded as a forerunner of the normal shaft tombs, and some of the vessels (e.g. Pl. 22:10, 16, 22) also incline one to believe in its earliness. However, the presence of a fine wheelmade cup (Pl. 22:19) which is of the same ware as the wheelmade "teapots" commonly found in normal shaft tombs indicates that it is not much earlier. This cup is so far unique at Megiddo. The angular zigzag of its decoration is to be contrasted with the wavy lines on "teapots" found in T. 877 (e.g. Pl. 91:24-26).

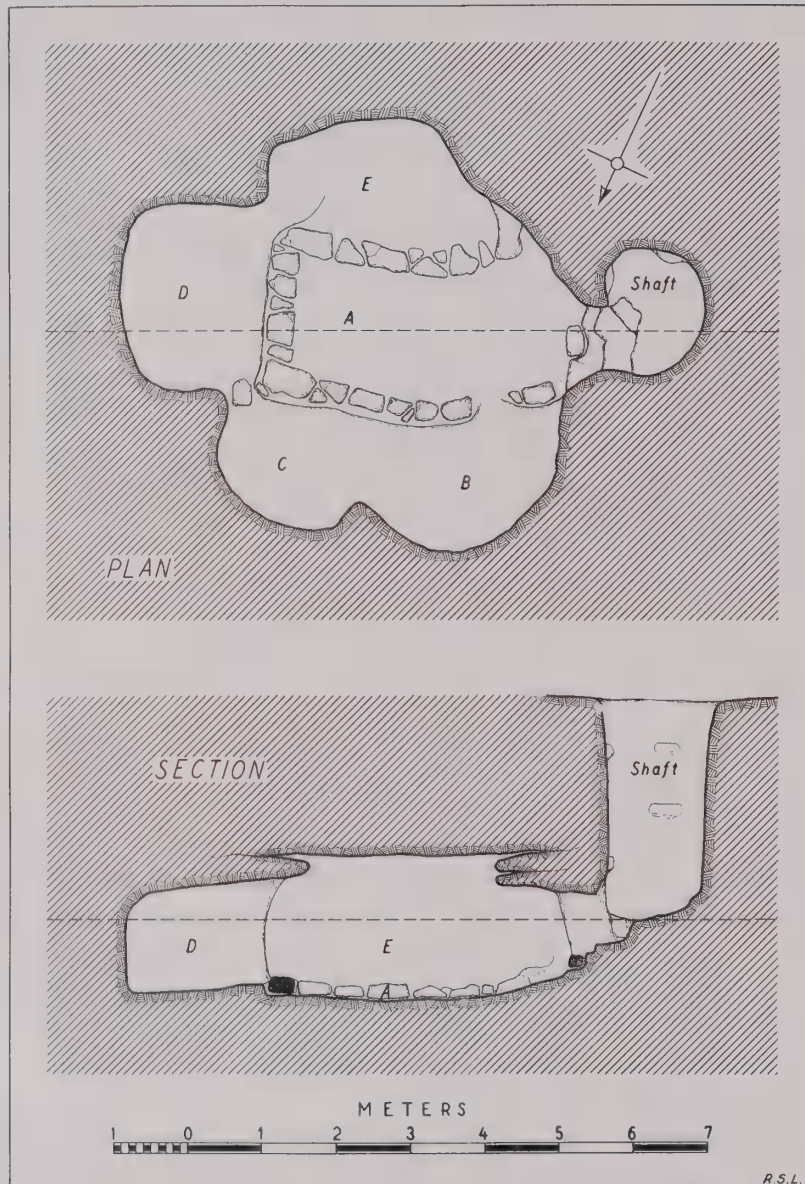

FIG. 48.—PLAN AND SECTION OF TOMB 1120. SCALE, 1:100

TOMB 24 IN SQUARE U 19

Tomb, MB I; contents, MB II and LB II  
 Contents illustrated on Pls. 23 and 103-7

Though nothing from MB I was found in this tomb, the fact that it is a shaft tomb (Fig. 49) indicates that it was cut during that period. The shaft was rounder than usual (cf. Fig. 168), and the entrance into chamber A was cylindrical. Quarrying had greatly damaged the upper portion of the tomb, and in chamber B part of the floor itself had been cut away. It is probable that another chamber had once existed to the west of A.

Since there had probably been a MB I burial in the tomb, the MB II and LB II material found must represent a second and a third occupation. The MB II material was found imbedded in a heavily compacted matrix brought about by a combination of roof collapse and ground water action in the interim before the LB II occupation. The MB II pottery presents a

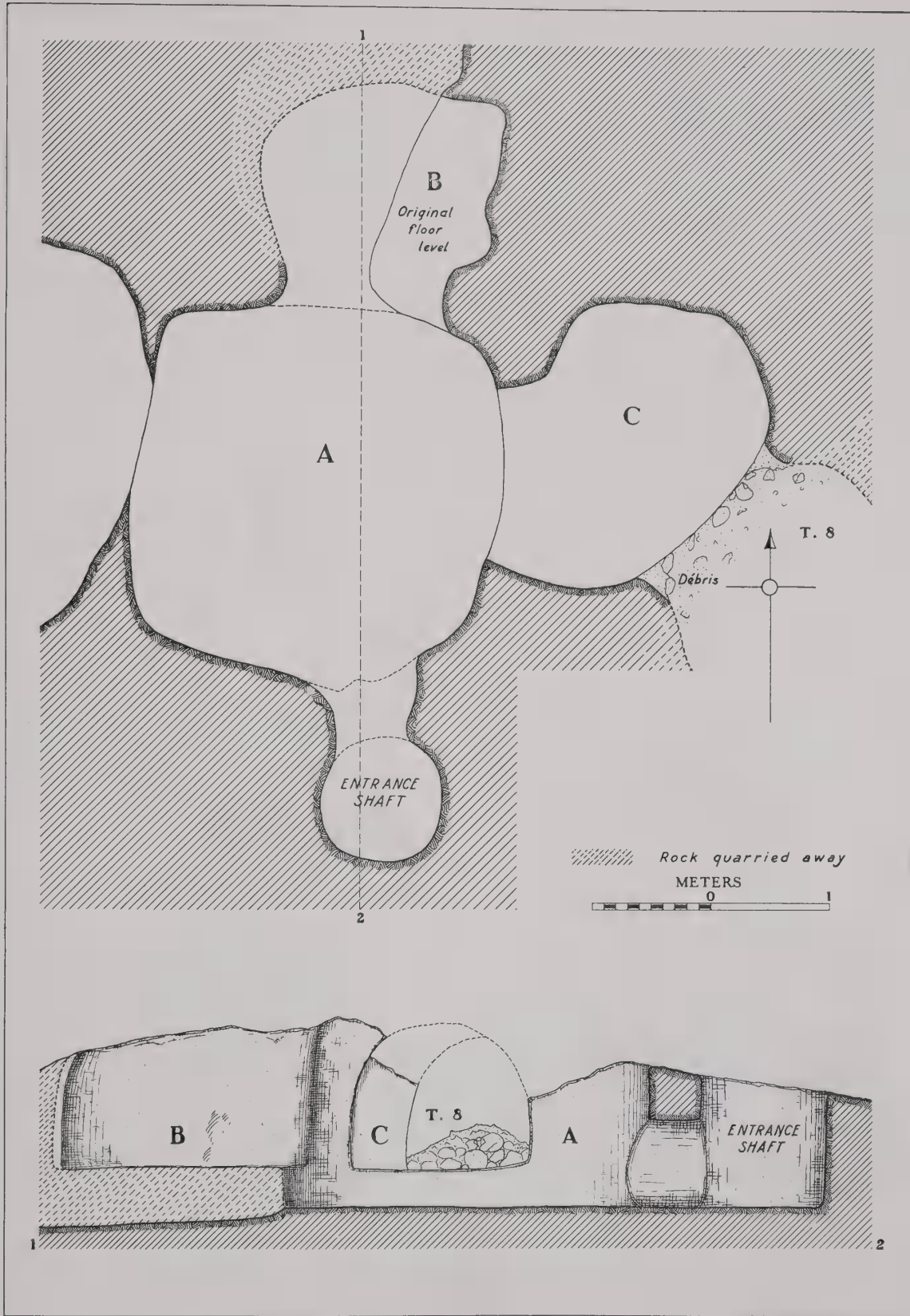

FIG. 49.—PLAN AND SECTION OF TOMB 24. SCALE, 1:50

homogeneous group, the collection of so-called "Tell el-Yahudiyyah" jugs (Pl. 23:23-30) being particularly fine. Exceptional among the other objects are an ivory box in the shape of a duck (Pl. 104) and twenty-eight Hyksos scarabs (Pls. 105-6).<sup>11</sup>

T. 8 seems to have been an independent and later cutting which became the repository for material discarded in the looting of T. 24 (see p. 101). Due apparently to the consolidation of the MB II layer in T. 24, little of that period was found in T. 8.

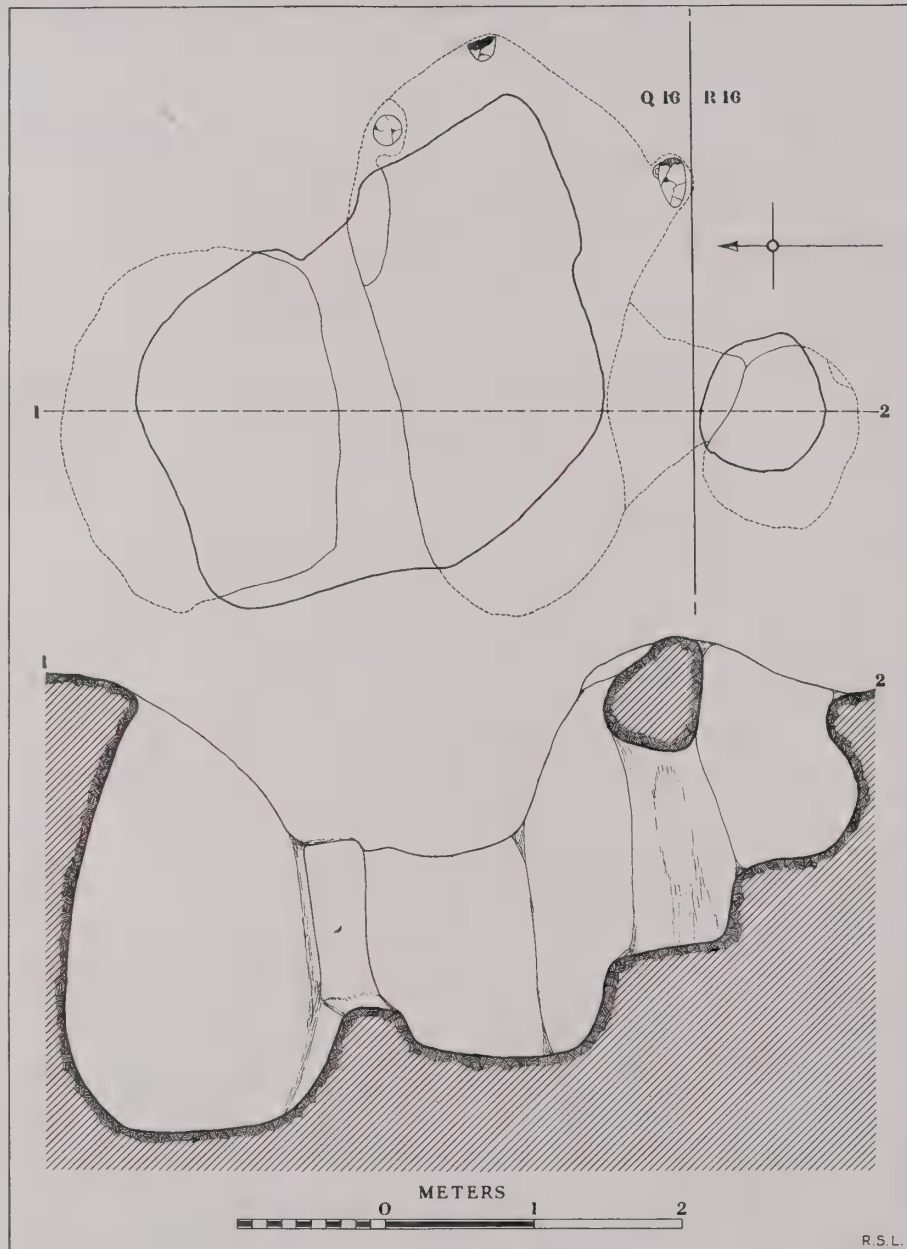

FIG. 50.—PLAN AND SECTION OF TOMB 42. SCALE, 1:50

<sup>11</sup> Erroneously attributed to T. 37 in *OIC* No. 4, Fig. 26.

## TOMB 42 IN SQUARES Q-R 16

Tomb, MB I(?); contents, chiefly MB II with some LB II  
 Contents illustrated on Pls. 24 and 107-9

Perhaps a very irregular shaft tomb. A roughly rounded shaft led down into two chambers (Fig. 50). The roof had collapsed. Most of the pottery found was MB II, but there were two bowls (Pl. 107:2 and 5) and some potsherds (not illustrated) belonging to LB II. One jug (Pl. 24:3) was imported from Cyprus. Some fine bone inlays (Pls. 108-9), found together but perhaps belonging to more than one piece of furniture, are similar to MB II inlays from T. 45 (Pl. 111).

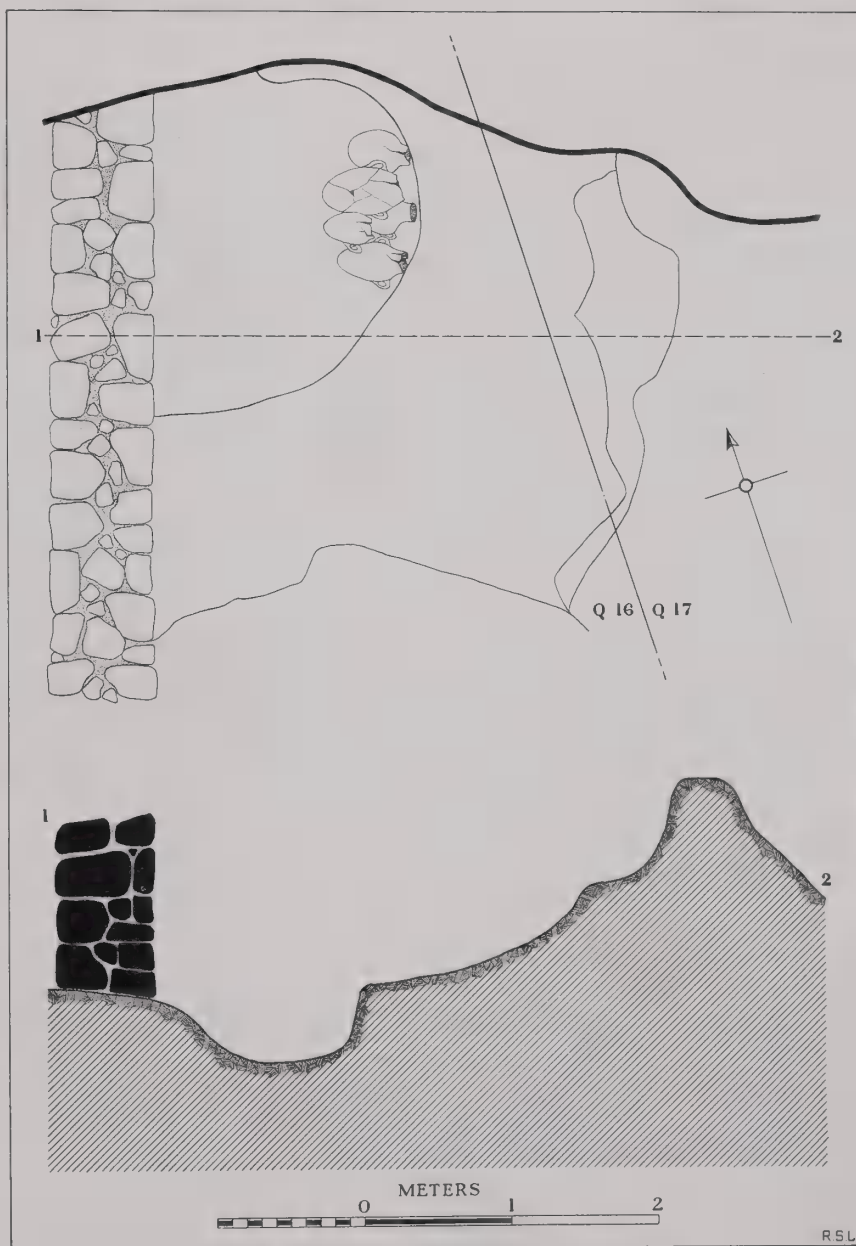

FIG. 51.—PLAN AND SECTION OF TOMB 45. SCALE, 1:50

## TOMB 43 IN SQUARE Q 16

MB II

Contents illustrated on Pls. 24 and 110

A small irregular pit in the rock (see Pl. 1), which yielded typical MB II pottery. A pottery whorl (Pl. 110:1) is comparable to one (Pl. 110:18) found in near-by T. 44, which is MB II also. The contents of T. 43 had all been disturbed.

## TOMB 44 IN SQUARE Q 16

MB II

Contents illustrated on Pls. 24 and 110

An irregular pit in the rock (see Pl. 1), which yielded typical MB II pottery. The contents had all been disturbed. A bead (Pl. 110:17*d*) represents the earliest glass found in the tombs.



FIG. 52.—TOMB 49, SHOWING MB II POTTERY

## TOMB 45 IN SQUARES Q 16-17

MB II

Contents illustrated on Pls. 25 and 111-12

A rough pit in the rock (Fig. 51), which was fairly well filled with MB II pottery, some of which was still *in situ*. The wall shown in the plan is later than the burial.

## TOMB 46 IN SQUARES Q-R 16

MB II

A rough pit in the rock, which contained two MB II jugs and a large MB II storage jar (not illustrated).<sup>12</sup>

<sup>12</sup> Jugs 1922-23 (cf. Pl. 114:1-2) and storage jar x 7107 (permanent brown 3 core, burnt umber 3 surface, coil-built, rope molding at base of neck, flat bottom; jug No. 1922 found in it).

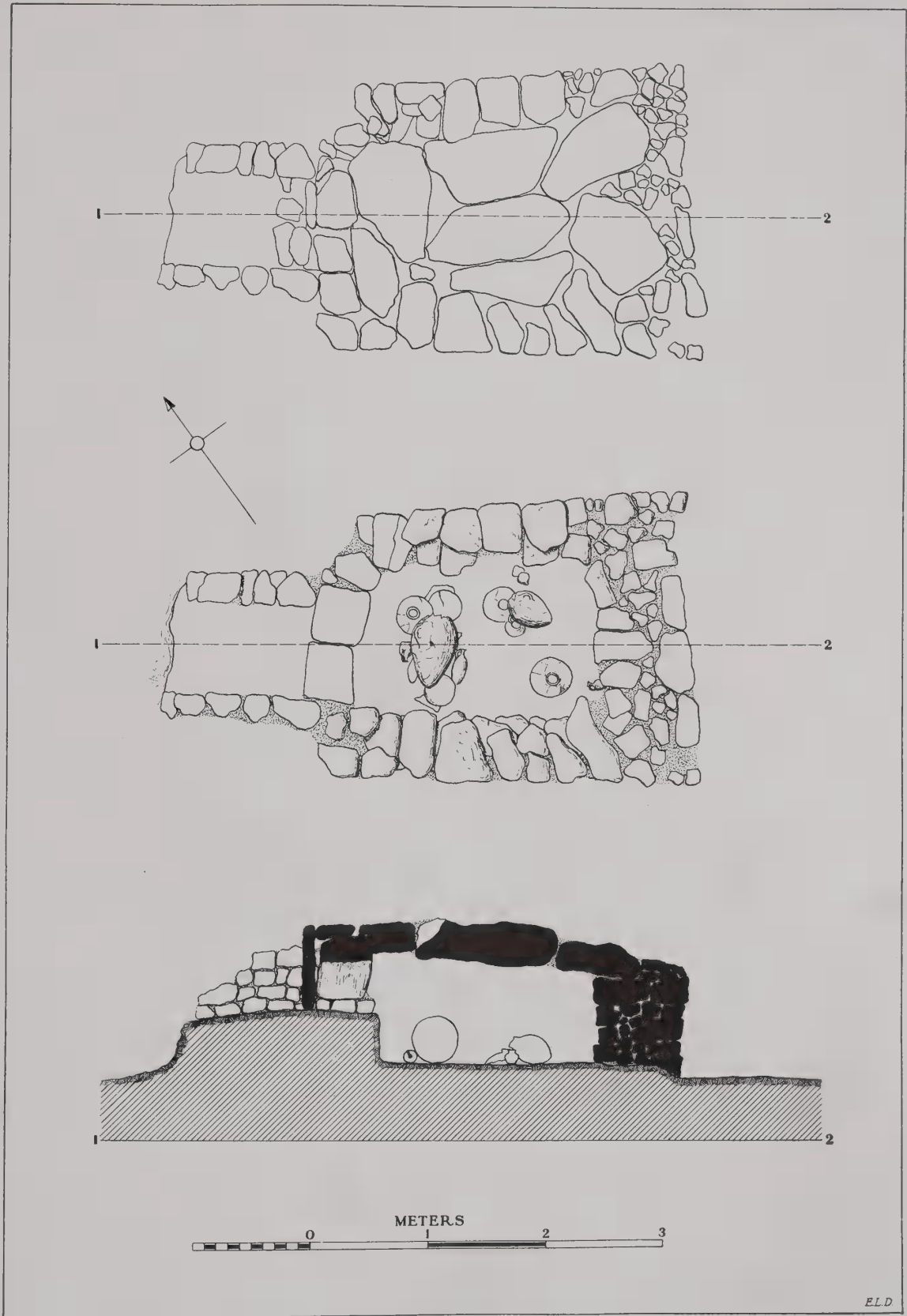

FIG. 53.—PLANS AND SECTION OF TOMB 51. SCALE, 1:50

## MEGIDDO TOMBS

## TOMB 49 IN SQUARE R 16

MB II

Contents illustrated on Pls. 25 and 112

A rough rectangular pit in the rock. As in other MB II pits, there had been no attempt to finish the sides (Fig. 52). The pottery is of particular interest because of the presence of a type unique at Megiddo (Pl. 25:6) in an otherwise homogeneous but disturbed MB II group.



FIG. 54.—TOMB 51 BEFORE REMOVAL OF ENTRANCE BLOCKING AND ROOF



FIG. 55.—TOMB 51 AFTER REMOVAL OF ENTRANCE BLOCKING AND ROOF, SHOWING MB II POTTERY

## TOMB 50 IN SQUARE R 15

Tomb, MB II; contents, MB II and LB II

Contents illustrated on Pl. 112

A rough pit surrounded by a circular wall of masonry. Two periods, MB II and LB II, are represented by the pottery (not illustrated). The stone implements shown on Plate 112 may belong to either period. It is probable that the masonry wall was erected for the later burial.

## TOMB 51 IN SQUARE R 16

MB II

Contents illustrated on Pls. 112-13

A masonry passage and chamber (Fig. 53) built over a cutting in the rock. After the burial the entrance to the chamber had been sealed with stones (Fig. 54). There was practically no skeletal material. The pottery is shown in Figures 55-56. Among the other objects found were four amethyst scaraboids and two steatite scarabs (see Pl. 113). Some disturbance had taken place.



FIG. 56.—TOMB 51 FROM ABOVE, SHOWING MB II POTTERY

## TOMB 53 IN SQUARE Q 16

MB II

Contents illustrated on Pl. 114

A small rough pit in the rock, which contained a fragmentary skeleton and two MB II pottery vessels (Pl. 114:1-2).

## TOMB 56 IN SQUARE R 15

Tomb, MB II; contents, MB II with intrusions

Contents illustrated on Pl. 114

Comparable to T. 51 (see above) in that its sides were built of masonry. No pottery was found, but an Egyptian "alabaster" jar (Pl. 114:7) similar to specimens found in Hyksos context at Tell Beit Mirsim and Tell Fara (see p. 186) together with the form of the tomb serves to date the burial. A leg fragment of an animal figurine (Pl. 114:8) and a spindle whorl (Pl. 114:3) were intrusive.

## TOMB 233 IN SQUARE S 15

MB II

Contents illustrated on Pls. 25-26 and 114

A roundish pit in the rock ( $1.6 \times 1.4 \times 2.3$  deep at maximum). It contained in addition to the pottery only a few fragments of human bone, but it was evident from the size of the pit that the burial had probably been at least partly contracted.

## TOMB 234 IN SQUARE S 15

MB II

Contents illustrated on Pls. 26 and 114

A pit (Fig. 57) in the rock ( $1.5 \times 1.0 \times .9$  deep at maximum). The bones were few and fragmentary, but the pit was so small that the burial had probably been at least partly contracted.

On the southeast edge of the pit a basalt bowl (M 741 in Fig. 58) had been let into the rock for the reception of offerings. A similar bowl (No. 4428 in Fig. 58) was set in the same relative position to what were at first thought to be cover slabs of another grave (see Fig. 57). How-



FIG. 57.—TOMB 234 WITH MB II POTTERY AND OFFERING-PLACE 235, SHOWING BASALT BOWL BESIDE EACH

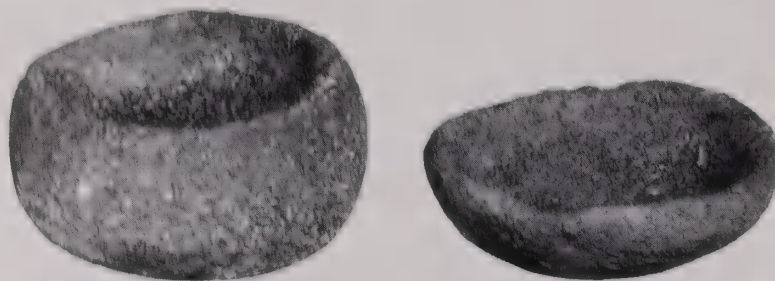

FIG. 58.—BASALT BOWLS FROM TOMB 234 (M 741 AT LEFT) AND OFFERING-PLACE 235 (4428). SCALE, 1:5

ever, when the slabs were removed it was found that they were not over a grave but had been bedded in some 5 cm. of earth which rested on natural rock. This locus (235) thus seems to have been an offering place or cenotaph associated with the group of pit graves near it and is of considerable interest as such.

## TOMB 244 IN SQUARE S 15

MB II?

A grave ( $1.6 \times .6 \times .5$  deep) surrounded by rough stones set in mud (Fig. 59). It had been completely looted and contained only three adult bones, but it belongs no doubt to the group of MB II graves near it.

## TOMB 247 IN SQUARE S 15

MB II

Contents illustrated on Pl. 26

Burial of an infant in a jar, mouth of jar to northwest. The embryonic position of the skeleton can be seen in Figure 60.<sup>13</sup> It was found in the extensive bed of rock chippings upon which room 238 (in Stratum ES II; see p. 2) was built, and part of the jar was directly under the southeast corner of that room. There were about 15 cm. of chippings between the base of the wall and the top of the jar, and the latter became visible only after the former was removed. The jar was set in plaster of Paris and removed as a block. It is similar to one (Pl. 27:4) from T. 253.



FIG. 59.—TOMB 244



FIG. 60.—TOMB 247, SHOWING CHILD SKELETON AND MB II JUGS

One could not well determine from the relative positions of burial and room whether the former was associated as a child sacrifice with the latter or not; but the small quantity of pottery found in Stratum ES II tends to place it in LB, whereas the pottery from T. 247 is good MB II and goes well with that of other MB II tombs near by. The strong probability, then, is that T. 247 is not a child sacrifice connected with room 238 but an earlier burial in the MB II cemetery which happened to be underneath.

## TOMB 251 IN SQUARE S 15

MB II

Contents illustrated on Pls. 26 and 115

A grave surrounded by rough stones and mud (Fig. 61; see also Fig. 65). It contained an adult (female?), partly contracted on left side with head to west-northwest, holding a child in

<sup>13</sup> Erroneously attributed to T. 37 in *OIC* No. 4, Fig. 28.



FIG. 61.—TOMB 251, SHOWING SKELETAL REMAINS AND MB II POTTERY



FIG. 62.—TOMB 252

a similar position. A smaller child, also contracted, with head to west, lay at the feet of the adult. All the bones were in very poor condition. About seventy sheep(?) astragali (e.g. Pl. 115:11) and a gold earring (Pl. 115:10) were found near the skull of the adult. A jug (Pl. 26:17) lay outside the grave and was perhaps placed there by a late-comer to the funeral after the grave itself had been covered. A similar jug (Pl. 26:18) lay against the wall of a room cut into by the grave.

## TOMB 252 IN SQUARE S 15

MB II?

A grave, surrounded by stones, in rock chippings about 20 cm. above the rock (see Fig. 65). Its similarity to T. 251 should place it in MB II. Only the remains of an adult, probably contracted (at right in Fig. 62), and those of another, partly contracted (at left in Fig. 62), were found.



FIG. 63.—TOMB 253, SHOWING MB II POTTERY



FIG. 64.—TOMB 254, SHOWING MB II BURIAL

## TOMB 253 IN SQUARES R-S 15

MB II

Contents illustrated on Pls. 27 and 115

Burial of an infant in a jar (Fig. 63; see also Fig. 65). The position of the much decayed skeleton could not be determined but was probably fully contracted like that in T. 247, which belongs to the same period.

## TOMB 254 IN SQUARE S 15

MB II

Contents illustrated on Pls. 27 and 115

Burial in débris of a child eight or ten years old, partly contracted on right side with head to northwest (Fig. 64). Some beads (Pl. 115:19) were found at the neck, and a scarab (Pl. 115:20) about 60 cm. east of the pelvis. Two fragments of flint (not illustrated) were close to the skeleton. The stones visible in Figure 65 belong not to the burial but to the southwest wall of a Stratum ES III room (see p. 2). The occupation of the room and the burial of the child cannot be far apart in time; perhaps the child was buried in its former home.

## TOMB 255 IN SQUARE S 15

MB II?

A rock-cut grave (1.5×.5×.3 deep; see Fig. 65). All that was found in it was a handful of human bones—just enough to show that it was a grave. There is nothing against its being contemporary with the MB II graves near it.

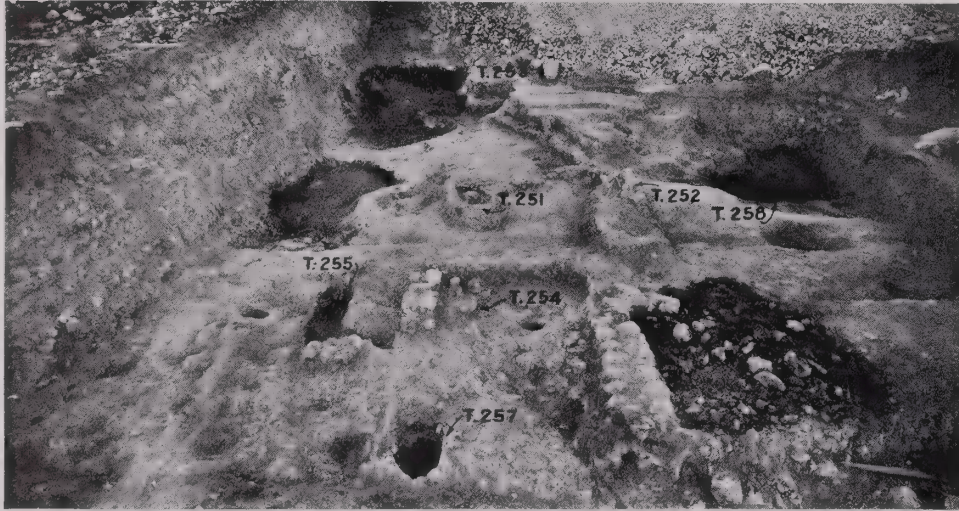

FIG. 65.—GROUP OF TOMBS IN SQUARES R-S 15, FROM SOUTHEAST

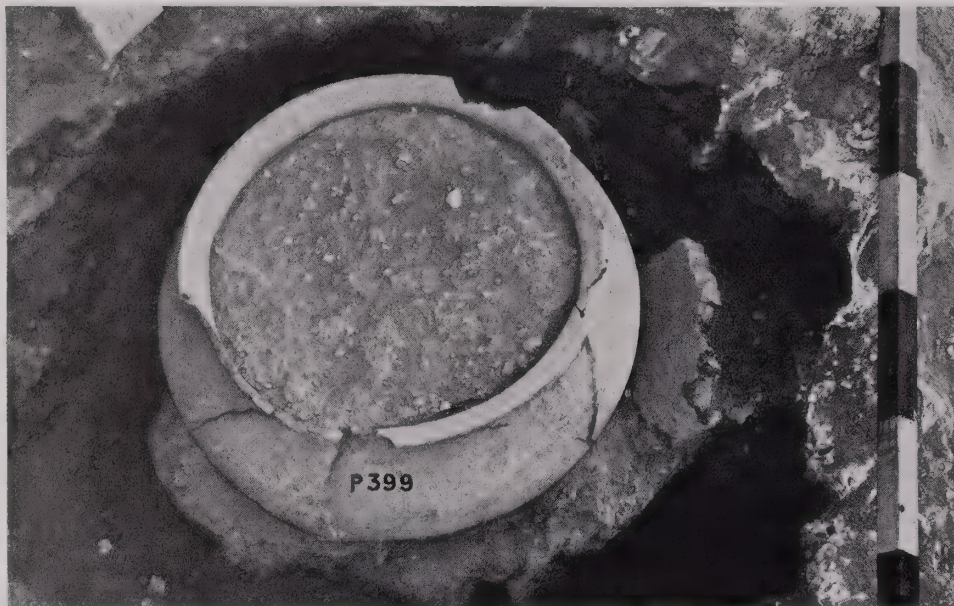

FIG. 66.—TOMB 257, POT BURIAL OF AN INFANT

## TOMB 257 IN SQUARE S 15

MB II?

A large cooking pot (Pl. 27:6) containing the contracted and much decayed skeleton of an infant. There was no furniture whatever. The pot was resting on several fragments of thick lightly fired pottery (Fig. 66), and a sherd of this was found on top of it. This pottery is like

that used for ovens, but there were no traces of fire. The situation of this burial near several MB II graves (see Fig. 65) suggests that it belongs to that period.

#### TOMB 258 IN SQUARE R 15

MB II

Contents illustrated on Pls. 27 and 115-16

Burial in débris (see Fig. 65) of an adult, partly contracted on left side but somewhat twisted onto back, hands crossed on chest and head to northwest (Fig. 67). In addition to the objects illustrated a few sheep bones were found, presumably part of a food offering.



FIG. 67.—TOMB 258, SHOWING SKELETON AND MB II POTTERY

#### TOMB 644 IN SQUARE R 4 (SEE FIG. 2)

MB II

Contents illustrated on Pls. 27 and 116

A burial on the extreme southwest edge of the summit of the mound covered only by some 60 cm. of surface soil. There were a few adult bones, but the position of the skeleton was quite indeterminable. There was no sort of grave structure, and it is possible that the burial had been removed in antiquity from a depression (1.10×.70×30 cm. deep) which lay just to the west.

#### TOMB 645 IN SQUARE R 4 (SEE FIG. 2)

MB II

Contents illustrated on Pls. 27 and 116

Burial of an infant in a jar of which only fragments were found (Fig. 68). It lay some twenty meters west of T. 644.

#### TOMB 868 IN SQUARE U 16

MB II

Contents illustrated on Pl. 27

Burial of a child in débris, apparently on right side with legs flexed and head to northwest. Fragments of the skull were found below jug P 2854 (Fig. 69 and Pl. 27:21).

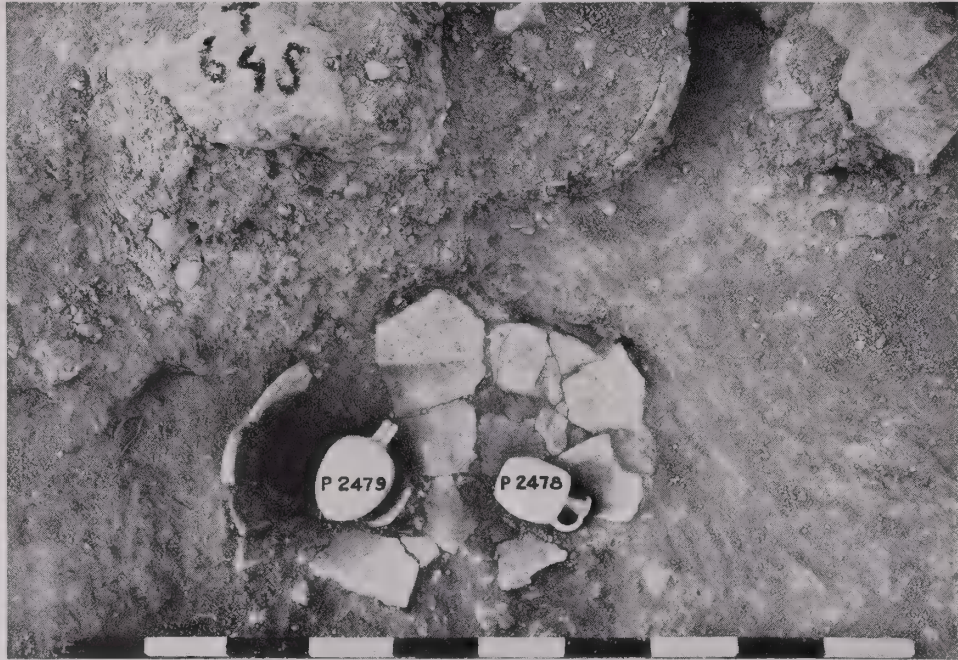

FIG. 68.—TOMB 645, MB II JAR BURIAL OF AN INFANT



FIG. 69.—TOMB 868, MB II CHILD BURIAL IN DÉBRIS

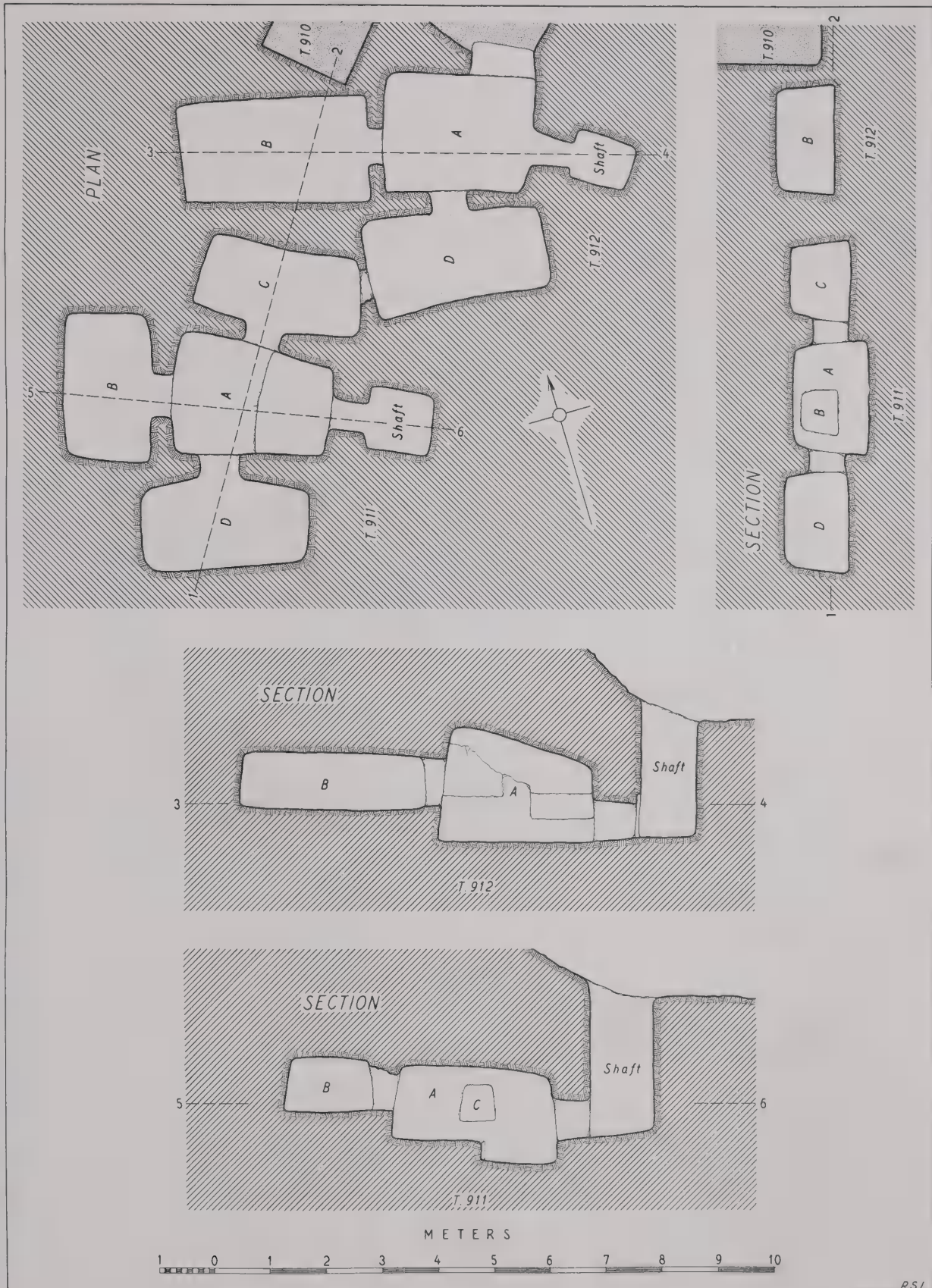

FIG. 70.—PLAN AND SECTIONS OF TOMBS 911-12. SCALE, 1:100

## TOMB 911 IN SQUARE V 17

Tomb, MB I; contents, MB and LB II

Contents illustrated on Pls. 28-32 and 116-22

A normal shaft tomb (Fig. 70). The shaft had both recessed and projecting footholds and a small step in the southeast corner. The entrance to chamber A had been blocked, unusually, by a wall of rough stones about the size of a man's head; the upper stones had been removed and were lying on the bottom of the shaft, but the lower stones were still in place. The usual cone of earth had got into A by way of the shaft, and D contained débris which had entered where the roof had been broken through by the makers of a later cistern or silo (locus 973); part of this débris had penetrated into A. There was a good deal of fallen roof in A, C, and D; B contained no intrusive débris and very little fallen roof. A robbers' hole connected C with



FIG. 71.—TOMB 911 A, SHOWING MB II AND LB II TOMB FURNITURE

T. 912 D. The rock surface of the chambers was very well finished, no tool marks being visible where it was exposed. Elsewhere the walls were covered with a coat of whitewash 1-2 mm. thick, this being definitely artificial and not a natural exudation from the rock. Patches of it can be seen on both sides of the entrance to B in Figure 71.

Chamber A contained remains of three periods. The earliest (MB I) are called T. 911 A 2, and the rest (MB II and LB II) are taken together as T. 911 A 1. The skeletal remains were for the most part scattered and in confusion. They all belonged to the same period (MB II on the basis of H 116) except for a few long bones found with MB I "teapots" (e.g. Pl. 31:2-3). Two skulls found near the entrance of B may have belonged to that chamber (see p. 67). In all, nine lower jaws were found, but only eight skulls (e.g. Fig. 203:4) and only one skeleton in position, an adult female (H 116). It lay on a rough rubble bed in the pit in the floor near the shaft, partly contracted on right side with head to east-southeast and back to the south

wall (Fig. 72). The head had apparently been propped up on a "pillow" of rock or dirt, since it was 20–25 cm. above the neck. The close association of the skeleton with jug P 3112 (see Fig. 72) and bowl P 3113 (Pl. 28:21) places it in MB II. An odd find was human hand bones in three MB II bowls (Pl. 28:6, 11, and 31), one of which (Pl. 28:6) contained a few human teeth also.

Confusion in chamber A was as apparent among the furniture as among the bones, the most remarkable case being that of a sherd lying just inside the entrance which fitted onto a "teapot" (Pl. 20:13) found in T. 878 A in square W 16. For the division of T. 911 A 1 into two groups we have on the one hand, in addition to some articles of both periods which had remained in position and gave actual stratification, certain vessels (e.g. Pl. 28:40–41) with



FIG. 72.—SOUTHEAST CORNER OF TOMB 911 A, SHOWING A MB I JUG (P 3114) ON THE ROCK FLOOR AND SKELETON H 116 WITH MB II POTTERY

MB II characteristics as well as duplicates of many of the MB II articles found in chamber D, and on the other hand well known LB II pottery types. The top layer of furniture consisted of LB II articles *in situ*, chiefly in the west and northwest parts, scattered LB II pottery, and disturbed MB II pottery (Fig. 73; see also Fig. 71). Underneath the top layer appeared MB II pottery more or less *in situ* (Fig. 74). A fine "bronze" stand (Pl. 119:1) was found with the LB II pottery vessels P 3051–53 (see Figs. 71 and 73 and Pl. 30:1, 4, 11). Corresponding marks on the stand and on P 3052 show that the latter once stood on the former. Three large LB II jars, P 3067–69 (Pl. 30:13–15), and a jug and a flask, P 3066 and P 3070 (Pl. 30:5–6), had not been interfered with (see Fig. 71). On the other hand a Cypriote milk bowl, P 3056 (Pl. 30:3), had obviously been disturbed, since part of it lay near the south wall and the rest of it against the north wall (see Fig. 71). Figure 71 shows also that P 3055 (Pl. 28:18), a MB II bowl, was lying upside down at a level higher than that of the LB II chalice P 3053

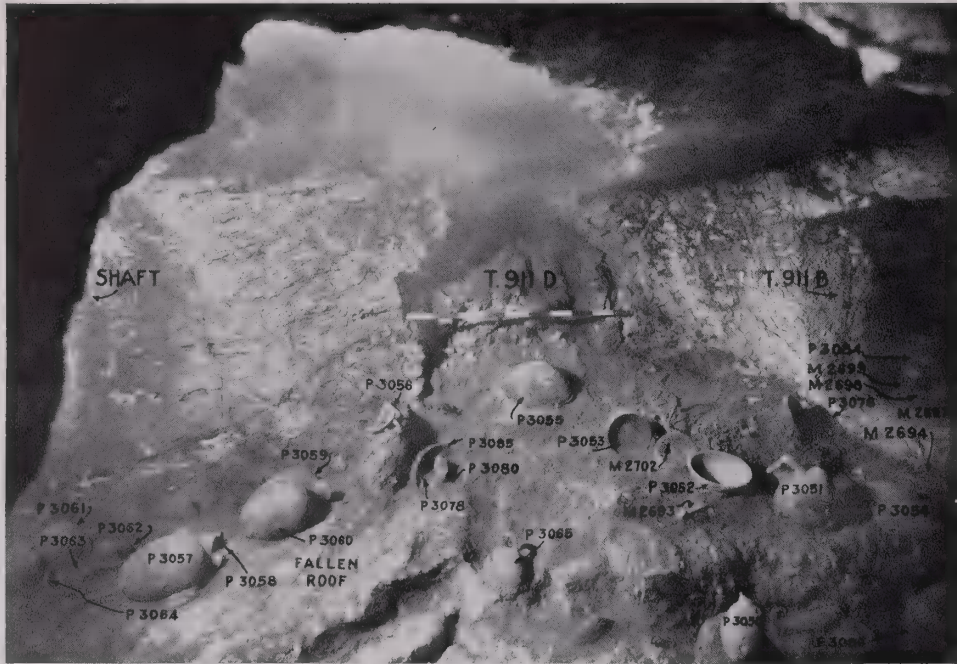

FIG. 73.—TOMB 911 A, SHOWING MB II AND LB II TOMB FURNITURE



FIG. 74.—TOMB 911 A AFTER REMOVAL OF FURNITURE SHOWN IN FIG. 71

(Pl. 30:4) and that P 3057 and P 3060 (Pl. 28:46-47), both MB II jugs, lay close beside the LB II jug P 3058 (Pl. 29:7). Other types of objects occurred low rather than high among the pottery and in no particular order. The group of weapons shown on Plate 118 is so strikingly paralleled by MB II weapons from chamber D that there can be no hesitation in associating it with the MB II pottery. It is to be noted that one of the dagger blades (Pl. 118:1) had been intentionally bent double or "killed" (see p. 137).

Chamber B showed the least evidence of disturbance, though even it cannot be said to have been inviolate. Just inside the entrance lay a "bronze" vase and two "bronze" bowls (Pl. 119:3-5). To the south of these was the only pottery vessel found in the chamber (Pl. 31:4), and beyond it was a small pile of animal bones under which were found the spindle whorls illustrated on Plate 119. Across the southeast corner lay two "bronze" knife blades (Pl. 119:17-18) in such a position with reference to the walls that, if they were still *in situ*, their handles cannot have extended more than a centimeter or two beyond the ends of the tangs. A gold earring (Pl. 119:10) lay near the southwest corner, and there was a second small pile of animal bones just inside and to the north of the entrance. The rest of the objects found in B were among the bones of the two adult skeletons which the chamber contained, a scarab (Pl. 119:11) lying at about the middle of one. These skeletons lay side by side on their backs with their feet to the north. All the bones were very crumbly, those of the bodies and arms having been reduced practically to powder. There was a considerable amount of white limey-looking substance in the region of the bodies, and on the legs several fragile flakes of what may have been skin and flesh. It is just possible that some attempt at mummification had been made. There were no skulls with the skeletons, but two lower jaws lay together against the west wall just opposite the entrance and about level with the hips of the skeletons. A number of human teeth were scattered to the north and northeast of the feet. A few bones of a child were associated with one skeleton. It is possible that two skulls, one very fragmentary, found in chamber A near the entrance to B (see p. 64) belonged really to the skeletons in B and that the LB II material in A should be associated with them, for everything in B appears to be LB II.

The human remains in chamber C were disposed in much the same manner as those in B and are attributed to the LB II period. There were two adult skeletons side by side on their backs with their feet to the east. Here again the bones were crumbly and poorly preserved. The upper parts were almost completely gone, and there were no skulls, though four teeth were found near the north wall at about the hip of one skeleton. A pile of animal bones lay near its feet. Where the skulls should have been, some fragments of bone and fallen roof had been swept together into a little pile covering a "bronze" bowl (Pl. 120:4). In this pile were numerous small objects (Pl. 120:5, 6, 8, and 10-11) also. In the southwest corner of the chamber near the pile lay a bronze knife blade (Pl. 120:14). An arrowhead (Pl. 120:12) lay about in the middle of the chamber partly under a large piece of fallen roof, and a spearhead (Pl. 120:13) had been driven into a hole in the wall in the southeast corner. The only pottery which the chamber contained (Pl. 31:5-7) lay just inside and northwest of the entrance, P 3232 (Pl. 31:6) being nearest the opening.

Chamber D produced an interesting group of weapons, dated by MB II pottery found with them, which showed that the custom of driving weapons into the rock existed certainly in MB II. On the rock floor in the southeast corner the only human remains were discovered. Fragments of an adult skull and three teeth lay under a pottery bowl (Pl. 31:10); the other bones had been disturbed, but their position suggested that the burial had been contracted. Pots P 3126-29, P 3131-32, and P 3136 (see Pl. 31) were all at the eastern end of the chamber, on or near the skeleton. P 3133-35 (see Pls. 31-32) and a bronze spearhead (Pl. 122:7) lay on

the floor farther west. A dagger blade (Pl. 122:9), a spearhead (Pl. 122:6), and an axhead (Pl. 122:2) had all been driven into the floor between the entrance and the skeleton. A similar axhead (Pl. 122:1) had been driven into the wall just east of the entrance and a little above it. Both axheads had been "killed" (see p. 137) by crushing the sockets. A basalt socket (Pl. 121:18) was found about 10 cm. above the rock floor. About 30–40 cm. above the latter a floor of beaten earth extended over the entire chamber. On it lay a group of MB II pottery (e.g. Pls. 31:8, 19–20; 32:2) and a "bronze" spearhead (Pl. 122:5). The latter is dated by the pottery and its similarity to spearheads found on the rock floor. There were no bones with this deposit. Above the earth floor was debris which had come through the hole in the west end of the roof (see p. 64). On the debris above the completely filled doorway lay a MB II bowl (Pl. 31:14) similar to others from both floors. Since it was not covered, it may be presumed that it was one of the last objects deposited in chamber D and that therefore the cistern or silo (see p. 64) was abandoned and filled in MB II. The similarity of material in the various deposits in this chamber suggests that all activity took place within a relatively short time.

Evidence from recent excavations on the tell seems to indicate that some of the MB II pottery from T. 911 may be as early as the 19th century B.C. (e.g. Pl. 28:2, 22, 32, 33, 38, 41–44, and 47), which would place all associated deposits that early. This early pottery is, however, later than the MB I burial in chamber A.

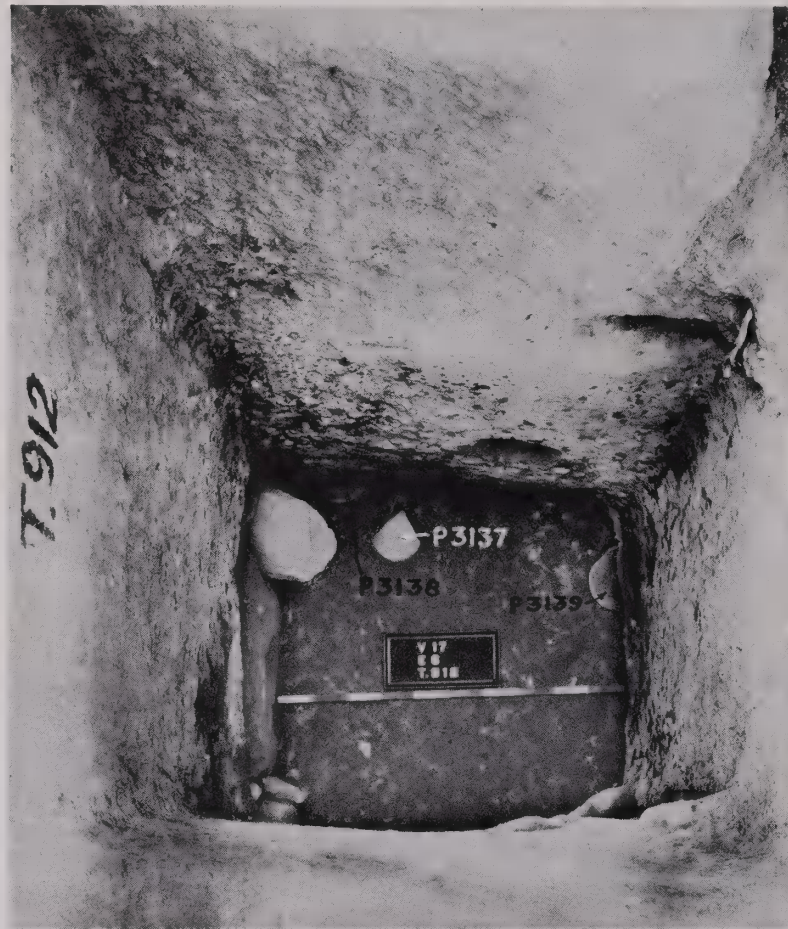

FIG. 75.—SHAFT OF TOMB 912, SHOWING LB II POTTERY. NOTE RECESSED AND PROJECTING FOOTHOLDS

## TOMB 912 IN SQUARE V 17

Tomb, MB I; contents, MB and LB II

Contents illustrated on Pls. 32-36 and 123-34

A shaft tomb without a chamber C (see Fig. 70). The makers had attempted to cut such a chamber but within a few centimeters had broken into T. 910 E and had apparently stopped,



FIG. 76.—TOMB 912 A, SHOWING LB II OBJECTS AND A MB II JUG (P 3444)

making no attempt to utilize the latter, which was at any rate partly filled with *débris*. Figure 15 shows clearly that it was the makers of T. 912 who broke into T. 910, and not the contrary. Thus T. 912 is certainly later than T. 910 (see pp. 17 f.). It is perhaps because no chamber C could be cut that chambers B and D, particularly the former, were made larger than usual. The blocking stone was found *in situ* in the entrance from the shaft to chamber A. On the floor of the shaft lay, unusually, a small collection of LB II pottery (Fig. 75). This goes well with that of the contemporary burial found in chamber A and may belong to it, though it can have been placed where it was found only after the entrance to chamber A had been closed by the blocking stone. Disturbance had taken place throughout the tomb, entrance having been effected by means of a hole leading from T. 911 C and perhaps also through a break in the roof of A leading into T. 910 E.

Chamber A was full of earth which had come in from T. 910 E. At 1.2 above the rock floor and directly below the break in the roof lay a group of LB II pottery (e.g. Pl. 32:12-14, 16, 18, and 20-21) which appeared to have filtered in from T. 910 E (Fig. 76). A basalt plate (Fig. 77) probably belongs with this group, which sloped away from the hole toward the center of the chamber. At .6 above the rock was a LB II burial represented by objects found *in situ* (e.g. Pls. 32:17, 19, 23; 33:4, 5, 7, 8; 123:15, 18-20; see Fig. 76). A MB II jug

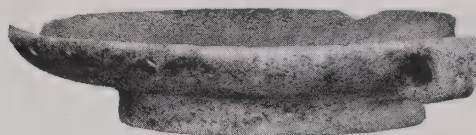

FIG. 77.—LB II BASALT PLATE (M 3191) FROM TOMB 912 A. SCALE, 1:5

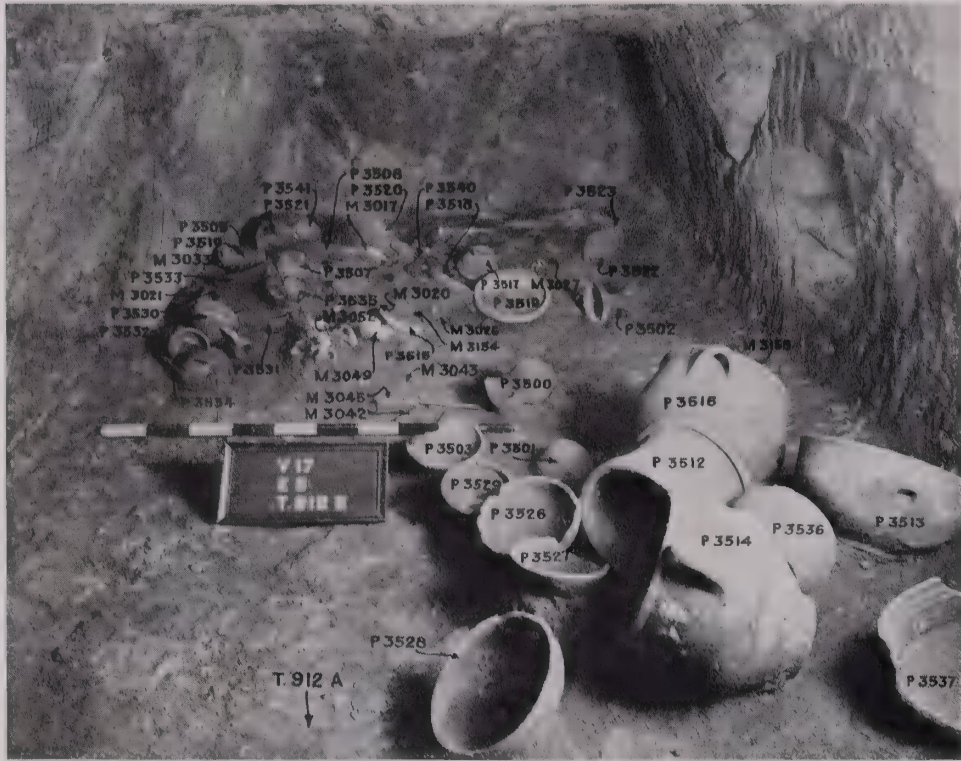

FIG. 78. TOMB 912 B, LOOKING WEST-NORTHWEST FROM ENTRANCE, SHOWING MB II AND LB II OBJECTS

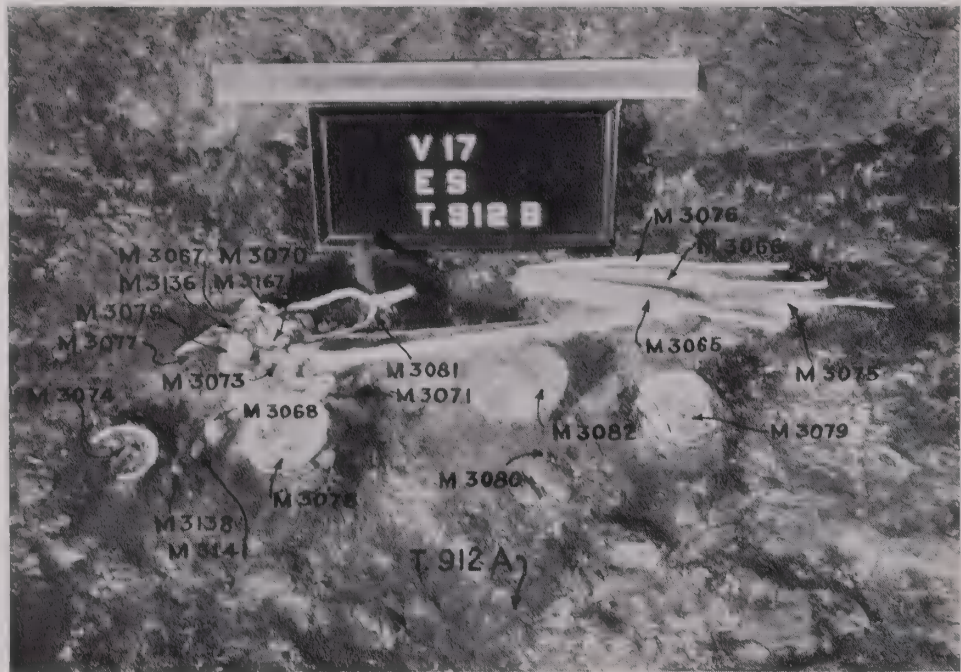

FIG. 79. TOMB 912 B FROM EAST, AFTER REMOVAL OF FURNITURE SHOWN IN FIG. 78



FIG. 80.—TOMB 912 D, LOOKING SOUTHWEST FROM ENTRANCE, SHOWING MB II AND LB II OBJECTS



FIG. 81.—TOMB 912 D FROM WEST, SHOWING MB II AND LB II OBJECTS

(Pl. 33:2) found near the entrance to B probably belongs to the MB II group in that chamber. A few centimeters above the floor were found three MB I vessels (Pl. 33:9-11), enough to indicate that, as is usual with shaft tombs, this tomb had originally belonged to that period. The only skeletal remains found in chamber A were a few skull fragments, which might have belonged either to the earlier or to the later burial.

Chamber B was only partially filled with dirt which had come through the doorway from A. It was the only chamber with whitewash on the walls, which were very carefully finished—more so than those of the other chambers. It contained a large quantity of LB II material (Figs. 78-79). But some of the pottery (e.g. Pl. 35:1-10) is similar to MB II pottery found in T. 911 and in spite of its being found mixed with LB II material is taken to belong to an earlier burial. A spearhead (Pl. 125:12) is of a type associated with MB II burials (cf. T. 911 D).

Chamber D was similar to B in that it contained both MB II and LB II pottery (see Pls. 35-36), but disturbance had been even greater. A good many vessels had been smashed to small bits and mixed with equally fragmentary bones out of which no order could be made (Figs. 80-81). It is extremely fortunate that the very fine LB II decorated jug P 3317 (see Fig. 81 and Pl. 134), known as the "Megiddo vase," had escaped damage. What few objects there were in addition to the pottery (see Pl. 133) belonged some to the earlier burial and some to the later.

The MB II burials in this tomb may, on the basis of the pottery, be as early as the 19th century B.C. (cf. p. 68).

#### TOMB 3 IN SQUARE R 18

Tomb, date uncertain; contents, LB and EI I  
Contents illustrated on Pls. 37 and 135

A cave in the rock (Fig. 82). The interior was in good condition, and the débris was stratified in practically the same manner as that in T. 2 (see p. 101), that is, a top layer of silt, then a layer of débris containing potsherds, and a floor layer. The entrance was through an outside shaft. Though the plan of the interior was irregular, it had undoubtedly been adapted, as tool marks showed, from an earlier and rougher cave. Around the walls were niches for separate burials, and in the floor were several well made circular pits nearly a meter in depth. The purpose of the two chambers approached by stairs is uncertain.

Since all of the pottery had been disturbed, it is difficult to date the other objects by their context. Both LB I and LB II pottery types were represented, and two EI I vessels (x 117 and x 119; see opp. Pl. 37) were found.

#### TOMB 6 IN SQUARE V 19

Tomb, date uncertain; contents, MB I and LB I  
Contents illustrated on Pl. 135

A small irregularly shaped cave which yielded a mixture of MB I (not illustrated) and LB I pottery.

#### TOMB 18 IN SQUARES V-W 19

Tomb, MB I(?); contents, LB I  
Contents illustrated on Pls. 38 and 135

A roughly circular cave which originally may have been a MB I shaft tomb with entrance at the south. The contents had all been disturbed.

#### TOMB 20 IN SQUARE V 19

Tomb, date uncertain; contents, LB I  
Contents illustrated on Pls. 38 and 135

An irregular cave with entrance probably at the south. The roof was gone. The skeleton of a young woman lay at full length on a bed of small stones and earth, face down, with head to

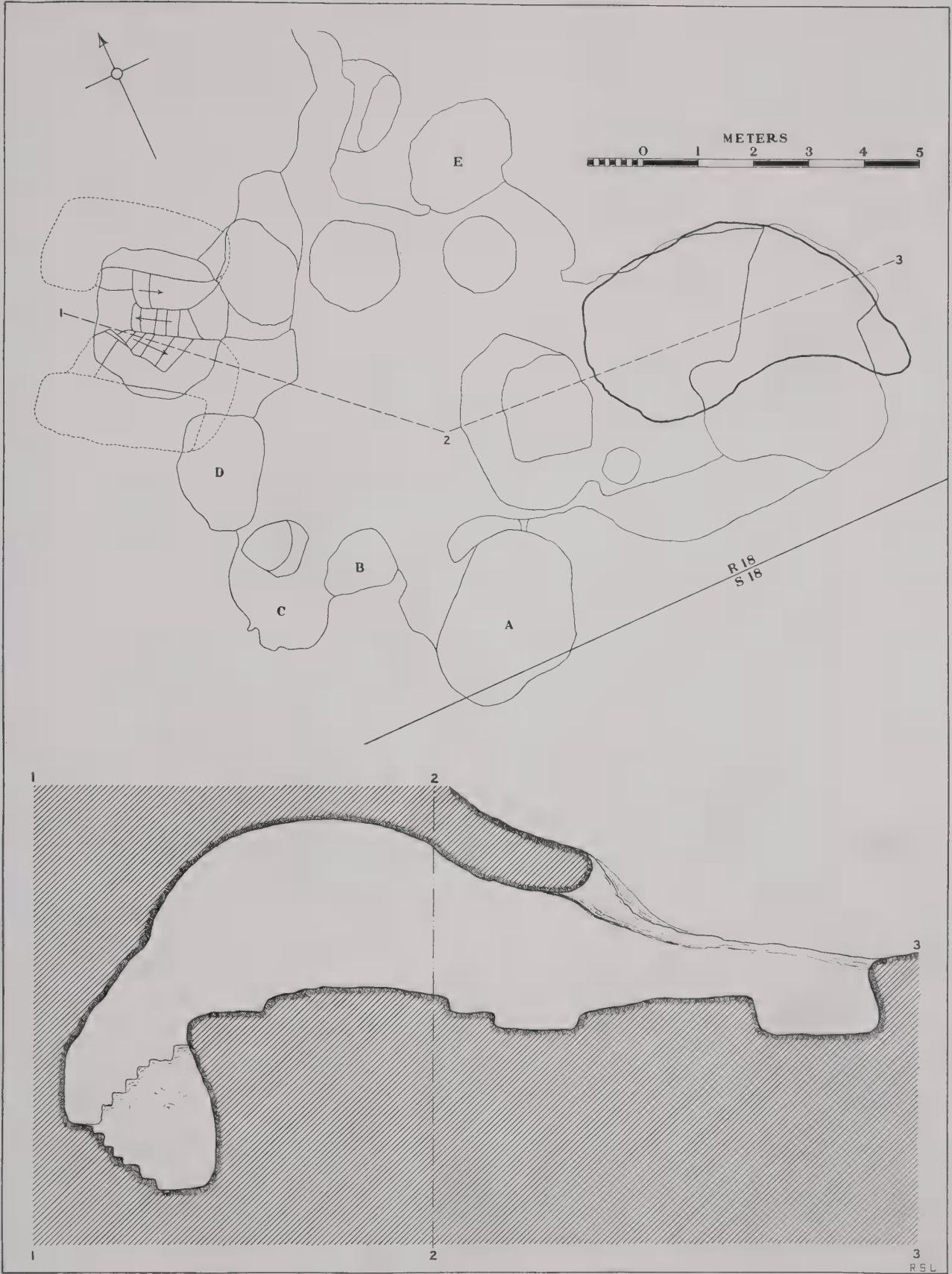

FIG. 82.—PLAN AND SECTION OF TOMB 3. SCALE, 1:100

south-southwest and arms bent under chest. This burial position is so far unique at Megiddo, yet one hesitates to say that it means other than orderly burial, for beads (Pl. 135:15) about the girl's neck and a sheep skeleton, probably a funerary offering, which lay just to the east of her, seem to indicate ritual. Just west of her was a small circular pit .45 in diameter partly filled with ashes, and on the floor near the body were other traces of ashes. Aside from the interesting group of beads, only a few potsherds were recovered.

TOMB 21 IN SQUARE V 19

Tomb, date uncertain; contents, LB

Contents illustrated on Pl. 38

An irregular cave from which came a group of badly broken LB I pottery (Pl. 38:11-14) and numerous LB II fragments (not illustrated).



FIG. 83.—TOMBS 37-38 AS EXPOSED BY ROOF COLLAPSE, WITH SHAFT OF TOMB 41 VISIBLE BEYOND

TOMB 37<sup>14</sup> IN SQUARES U-V 19

Tomb, date uncertain; contents, mixed

Contents illustrated on Pls. 38-40 and 136-39

A cave in the rock, with collapsed roof (Fig. 83). Because of the tremendous rock movement which had taken place much of the original detail was lost, and there are elements of uncertainty in the plan (Fig. 84). The original entrance was probably to the south. The cave was connected with T. 38 by a rough break in the wall between them. This break probably occurred late in the history of the caves. The pottery from T. 37, though not all stratified due to periodic disturbance, indicates practically continuous occupation from MB I through MI times; and the types of deposit show that the cave had been put to both funerary and domestic uses.

<sup>14</sup> In *OIC* No. 4, Figs. 26 and 28, a group of scarabs from T. 24 (our Pls. 105-6) and T. 247 (our Fig. 60) were mistakenly attributed to T. 37.



FIG. 84.—GENERALIZED PLAN AND SECTIONS OF TOMB 37. SCALE, 1:100

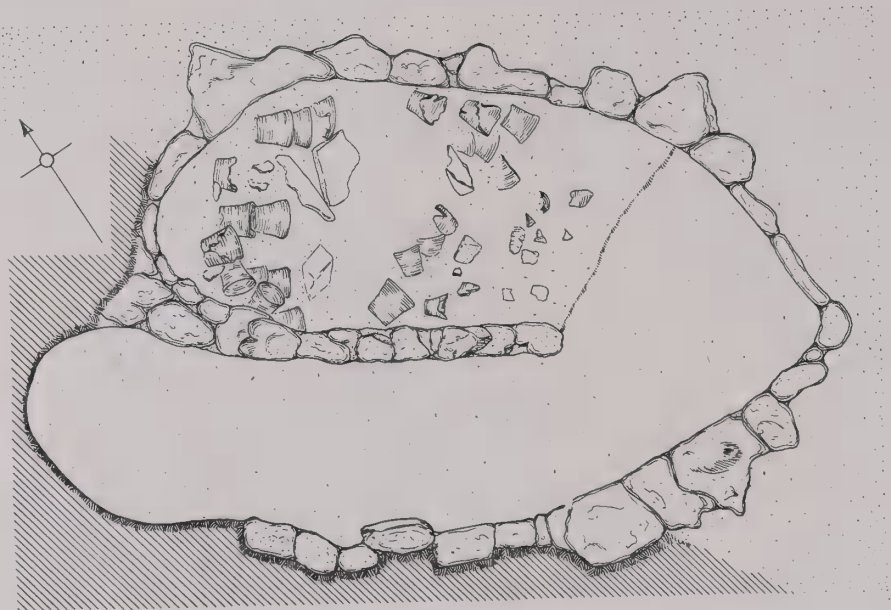

FIG. 85.—PLAN OF KILN 22 IN TOMB 37. SCALE, 1:40

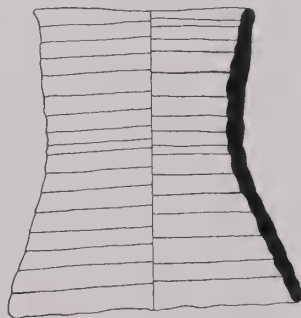

FIG. 86.—MI POTTERY JAR-STAND (x 2) FOUND IN KILN 22. SCALE, 1:5

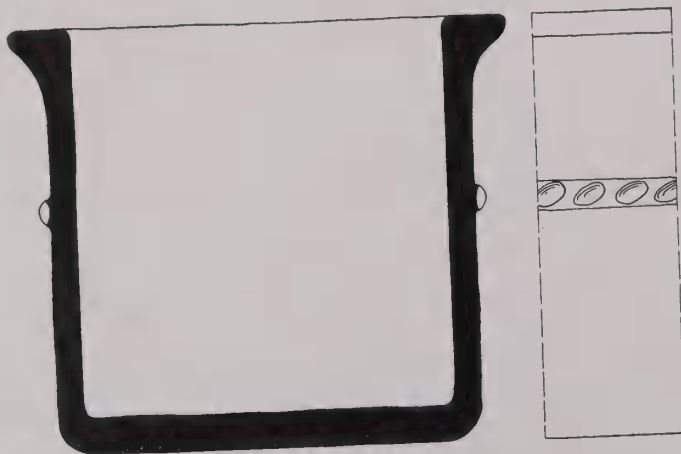

FIG. 87.—RECONSTRUCTION OF MI POTTERY BATH (x 28) FROM FRAGMENTS FOUND IN KILN 22. SCALE, 1:10

The uppermost layer was represented by three kilns, an oven, and some well cut stones (see Fig. 84). Kiln 33 was built upon a thin floor of crushed limestone, in which were found pieces of the cave roof, and plastered with mud which had been subsequently baked. The kiln contained typical MI pottery (not illustrated), the bowls having a light red wash inside and over the rim.

Kiln 22 (Fig. 85) stood to the east of No. 33. Its northeast half was practically filled with MI pottery jar-stands (e.g. Fig. 86).<sup>15</sup> These, numbering about 30, were nested and lay in long lines parallel to the sides of the kiln. Fragments of a large pottery bath of a type known from the MI period on the tell<sup>16</sup> were found lying on the jar-stands. Figure 87 gives a reconstruction as far as it was possible to carry it. The length could not be ascertained, but presumably it was about twice as long as it was broad. It was of coarse black ware with a red slip. The rope molding was apparently continuous on all sides. The position of the bath fragments suggests that they had constituted part of the roof of the kiln. The other half of the kiln was empty, and the entrance was sealed with stones.

The sides of Kiln 23 (Fig. 88) were plastered with baked clay, and the entrance was sealed with stones (*H* in Fig. 89). Nothing was found in it, but it is of particular interest because it yields evidence, although extremely fragmentary, of a flue system (Fig. 89). The draft, entering through the rough blocking at *H*, would divide and travel through *A* and *B*, then proceed into the vents *F* to *C* and *G* to *D*, and converge in *E* to be carried off by a superstructure concerning which we have no evidence.

Under the layer of crushed limestone on which Kiln 33 was built was a layer of crushed bone (see Fig. 84). The mass of bones was too badly disintegrated to distinguish separate bones, but Dr. Fisher's impression was that it represented human remains.

In the sub-loci discussed below (*A-P* in Fig. 84) remains of various periods were found. Some of these may have belonged to the occupation represented by the kilns; others cannot be dated.

#### 37 A

An irregular pit in the rock floor containing chiefly LB I (see Pl. 39) with some MB I (not illustrated) and LB II (Pl. 39:11) pottery. Other objects from this pit are shown on Plate 137. The contents had been disturbed.

#### 37 B

A rectangular grave with rounded corners in the rock floor. The skeleton of an infant lay at full length on its back, with head (missing) to south (Fig. 90). On the left upper arm was an iron bracelet (Pl. 137:14). No pottery was found, but the burial presumably belongs to the Iron Age, and, since it was covered by a floor on which rested a MI deposit (Kiln 33), its period is limited accordingly.

#### 37 C

Two connected pits in the rock floor in each of which was a secondary cutting containing a child burial (Fig. 91).

C 1 was a rectangular grave with rounded corners. It extended under the floor leaving an overhanging ledge. The skeleton of an infant lay at full length on its back, with head to east (see Fig. 91). No definite date can be assigned to the burial, since no objects were found with it. Apparently C 1 was cut after C 2, but both must be older than the floor under Kiln 33. The similarity of the burial position to that in B and the similarity of the cutting to T. 17 (see Fig. 142) and T. 62 (see Fig. 146), which are both EI I, should be borne in mind.

<sup>15</sup> Some mixed grits, poorly fired, permanent yellow 3.

<sup>16</sup> See *OIP* XLII, Pl. 18, No. 91.

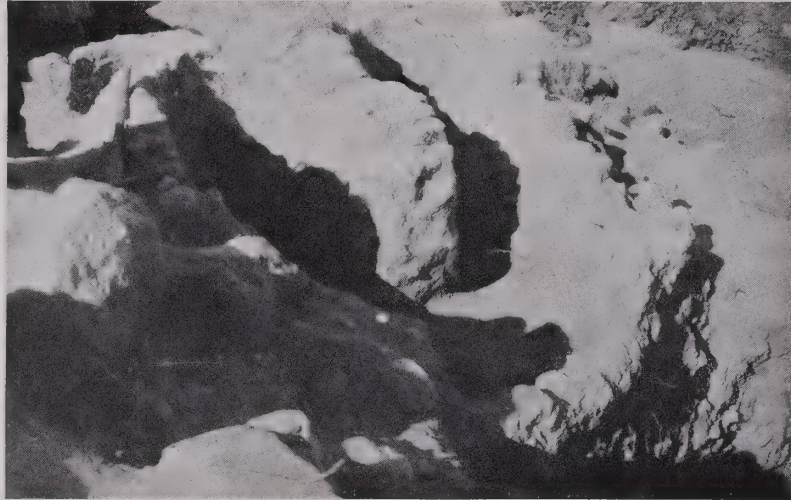

FIG. 88.—KILN 23 IN TOMB 37

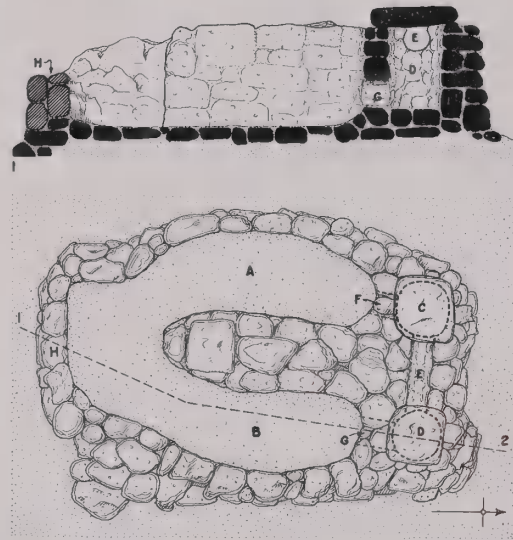

FIG. 89.—PLAN AND SECTION OF KILN 23, SHOWING DETAILS OF FLUE SYSTEM. SCALE, 1:40

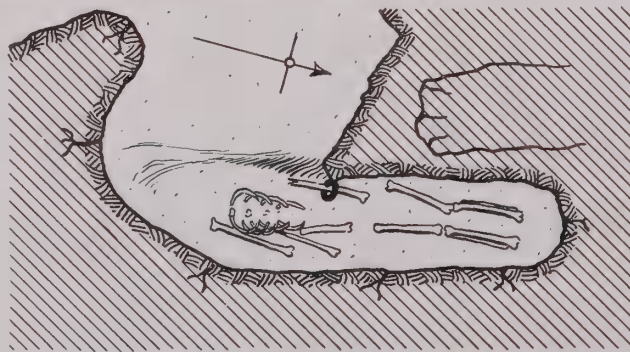

FIG. 90.—PLAN OF TOMB 37 B, SHOWING INFANT SKELETON WITH IRON BRACELET ON LEFT ARM. SCALE, 1:20

C 2 was an irregular hole containing an E I I jar (Pl. 137:15) in which lay an infant, less than a year old. The top of the jar had been broken to allow insertion of the skeleton. The bones were greatly disturbed and quite incomplete. In the débris within the jar were four "bronze" bracelets (see Pl. 138), two with fragments of coarse cloth adhering, and numerous beads (Pl. 138:4-5).

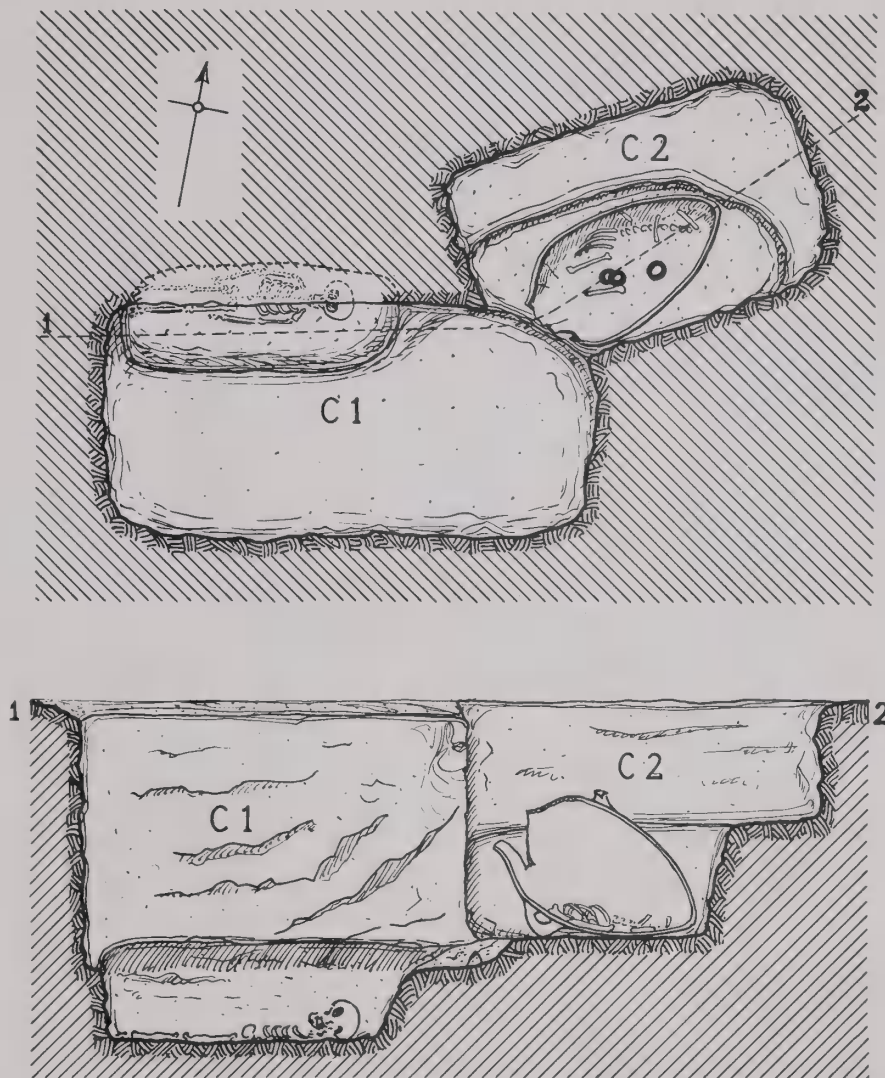

FIG. 91.—PLAN AND SECTION OF TOMB 37 C 1-2. SCALE, 1:20

### 37 D

A grave with overhanging ledge (cf. C 1) in a pit in the rock floor. It was found empty but is presumably contemporary with C 1.

### 37 E

A well cut circular pit in the rock floor narrowing toward the top. It was probably a cistern, like other cuttings of a similar nature found on the side of the hill. It contained broken Iron Age pottery (see Pls. 39-40 and 138) and a scarab (Pl. 138:7).

## 37 F

Similar to E except for greater asymmetry. The walls were plastered, as one would expect in a cistern. It had apparently been deliberately filled with earth and disused pottery, all MI (see Pls. 40 and 138).

## 37 G

A roughly circular pit with fairly steep sides in the rock floor, use unknown. A few MI sherds (not illustrated) were found in it, and a tall well cut limestone block stood to the south of it.

## 37 H

A shallow pit in the rock floor containing a worn stone socket (not illustrated) perhaps used in turning pottery. There was no evidence as to the date of the pit.



FIG. 92.—TOMB 37 M, SHOWING LB I JAR BURIAL



FIG. 93.—PLAN OF TOMB 37 M. SCALE, 1:20

## 37 J

A roughly rectangular burial(?) pit with rounded corners within another pit in the rock floor. A few MB I and MI sherds (not illustrated) were found in the débris, but they mean nothing as regards the date of cutting.

## 37 K 1

A burial in débris. An adult skull and a few bone fragments were found mixed with MI pottery (not illustrated), an obvious case of disturbance. This burial had no connection with 37 K 4.

## 37 K 4

A roughly oval pit in the rock floor containing a LB I jar burial (cf. 37 M). The bones, those of an infant less than a year old, were fragmentary. Numerous small pottery vessels as well as a scarab, beads, and other objects (see Pls. 40 and 138) came from the pit.

## 37 L

A shallow depression in the rock floor containing an EI I jar like that found in C 2 (see above). There was nothing in the jar, although it may once have contained a child. Fragments of the jar were found in M, indicating disturbance. A small mass of broken pottery (not illustrated) lay in the northwest corner of the depression.

## 37 M

A pit in the rock floor containing a LB I jar burial (Fig. 92).<sup>17</sup> The jar was flanked by stones where the rock was low (Fig. 93) and thus banked all around. The skeleton, that of an infant less than a year old, was undisturbed and lay partly contracted on left side, with arms extended toward knees and head to northwest. Small LB I pottery vessels (see Pl. 139) had been placed outside of the burial jar.



FIG. 94.—MI JARS FOUND IN TOMB 37 N OUTSIDE KILN 33

## 37 N

Probably a storage place for pottery which had been baked in Kiln 33. It was situated on débris. It contained a large group of hole-mouth jars (Fig. 94; see also Pl. 139:8) which are of the same date (MI) as the pottery found in the kiln itself.

## 37 O

A grave with overhanging ledge (cf. C 1 and D) in a pit in the rock floor. Like D it was empty but was probably cut at the same time as C 1.

## 37 P

A side chamber of the main cave. In the rock floor were two shallow oval pits in which nothing was found. The alcove had apparently been cleared out.

In addition to the articles from the various sub-loci discussed above, others were found which could not be assigned specifically to any sub-locus—LB, EI, and MI objects, including seven Hyksos scarabs (see Pls. 38–39 and 136–37).

<sup>17</sup> Fig. 28 in *OIC* No. 4, intended to illustrate this burial, is actually a photograph of T. 247, a similar burial (our Fig. 60).

## TOMB 38 IN SQUARE U 19

Tomb, date uncertain; contents, LB I and LI?  
 Contents illustrated on Pls. 40-41 and 139-40

A cave, with one large chamber and a side chamber (B), comparable in size with T. 37 with which it was connected by a break in the wall between them (see p. 74 and Fig. 83). The floor was pitted like that of T. 37. The pottery, though most of it had been disturbed, showed that the cave had been used principally in the LB I period. To a later period, just which is uncertain, belong two kilns. Both were cut into the rock floor, but their superstructure had disappeared. No doubt they had been finished in masonry. Both showed traces of mud plastering. One was full of ashes, the other was blackened by smoke. There were a few LI(?) objects (Pl. 139: 26-28).



FIG. 95.—TOMB 75 FROM EAST, SHOWING SKELETAL REMAINS AND LB I POTTERY

## TOMB 75 IN SQUARE S 15

LB I

Contents illustrated on Pls. 41 and 140

A double adult burial in débris, practically on the rock (Fig. 95). Both skeletons had been greatly disturbed and were fragmentary. The pottery (Pl. 41:21-24) is similar to that from T. 1100 (see Pls. 45-48), which is considered the type group for LB I (see p. 89.)

## TOMB 77 IN SQUARE S 16

LB I

Contents illustrated on Pls. 41-42 and 140

A rock-cut chamber approached by a short passage (Figs. 96-98). On the northeast side a hole 1.3 high and .6 wide had been broken through the wall. On the southwest side was a recess large enough for a full-length adult burial, with a ledge in front, about 45 cm. higher than the floor. Nothing was found in the recess, all furniture being on the floor of the chamber, with a few bones but no remains of skulls.



FIG. 96.—ENTRANCE TO TOMB 77



FIG. 97.—INTERIOR OF TOMB 77 FROM EAST

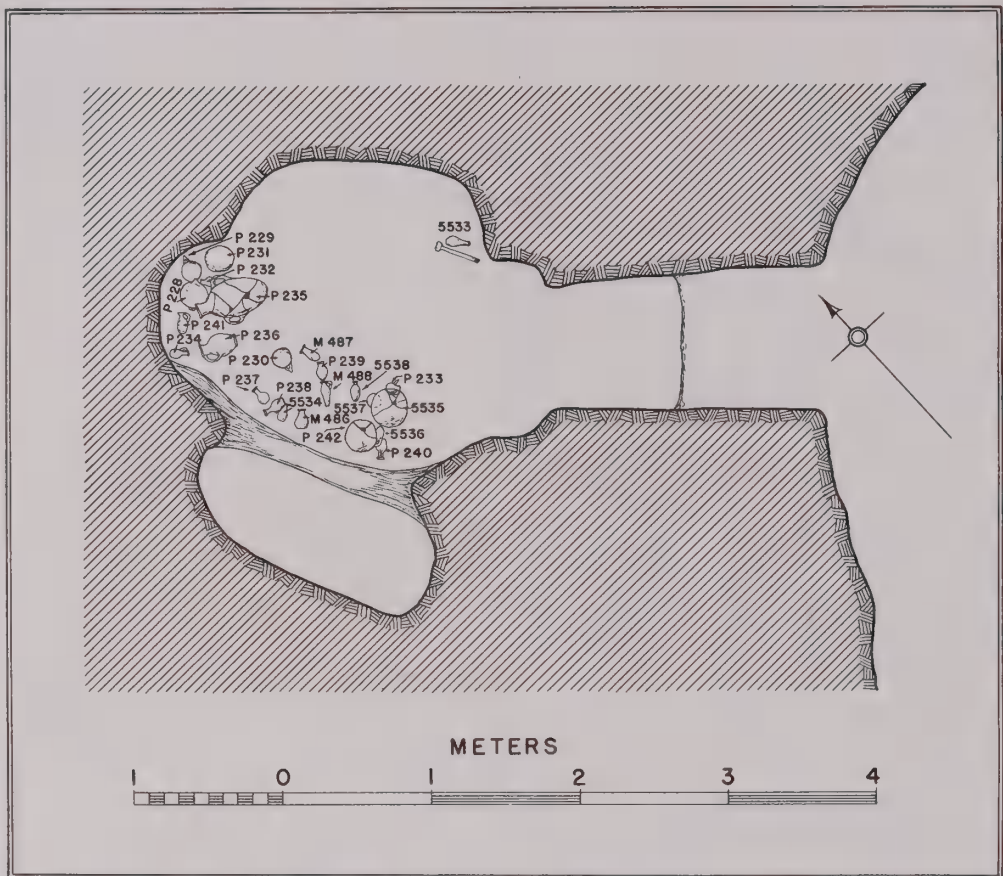

FIG. 98.—PLAN OF TOMB 77. SCALE, 1:50



FIG. 99.—TOMB 78 FROM NORTHEAST, SHOWING SKELETAL REMAINS AND LB I POTTERY

## TOMB 78 IN SQUARE S 16

Tomb, LB I; contents, LB I with intrusions  
 Contents illustrated on Pls. 42 and 141

Apparently similar in shape to T. 77 (see Fig. 98), but most of the chamber had been destroyed, and no plan could be made. The recess, however, remained. The burial, which was probably at full length, had been disturbed, but the position of the leg bones showed that the head lay to northwest (Fig. 99). The pottery forms a homogeneous group except for two bowls (Pl. 42:22-23) which are obviously intrusive.

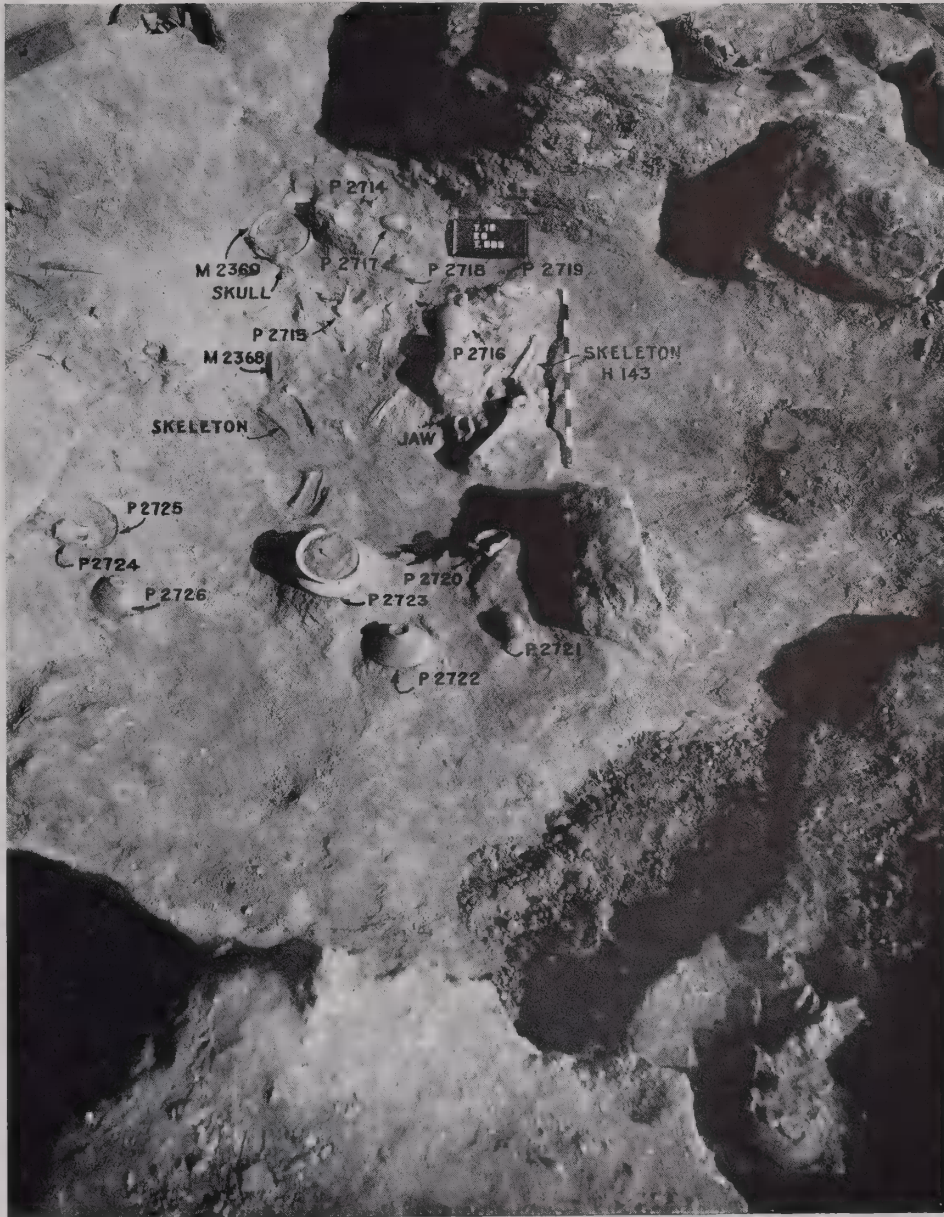

FIG. 100.—TOMB 855 FROM SOUTH, WITH SKELETON H 144 IN TOMB 856 VISIBLE IN LOWER RIGHT-HAND CORNER

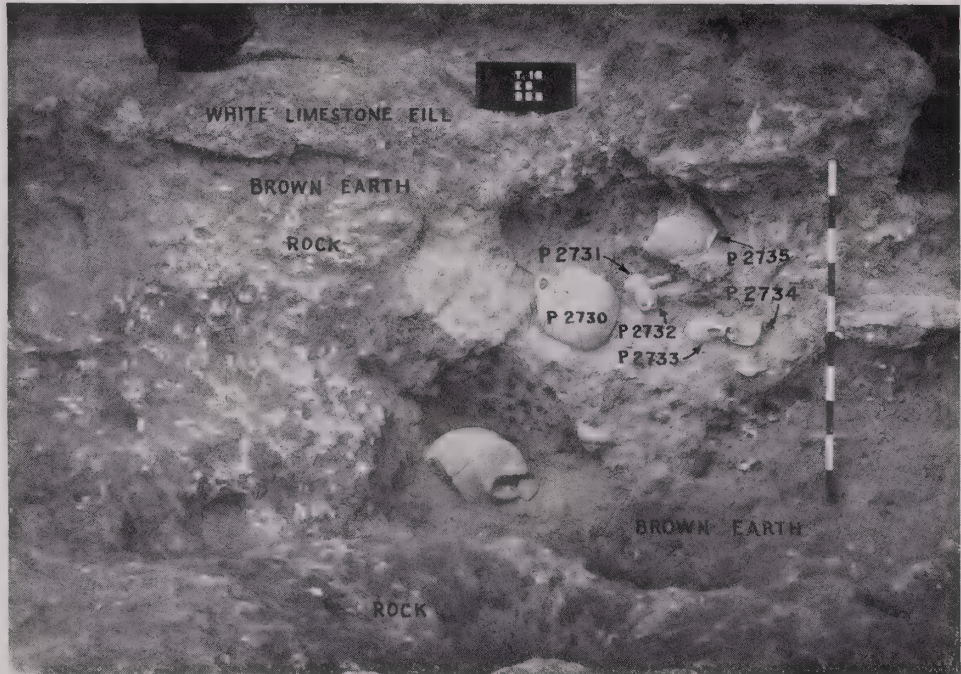

FIG. 101.—TOMB 855 FROM SOUTH AFTER REMOVAL OF OBJECTS AND SKELETAL REMAINS SHOWN IN FIG. 100

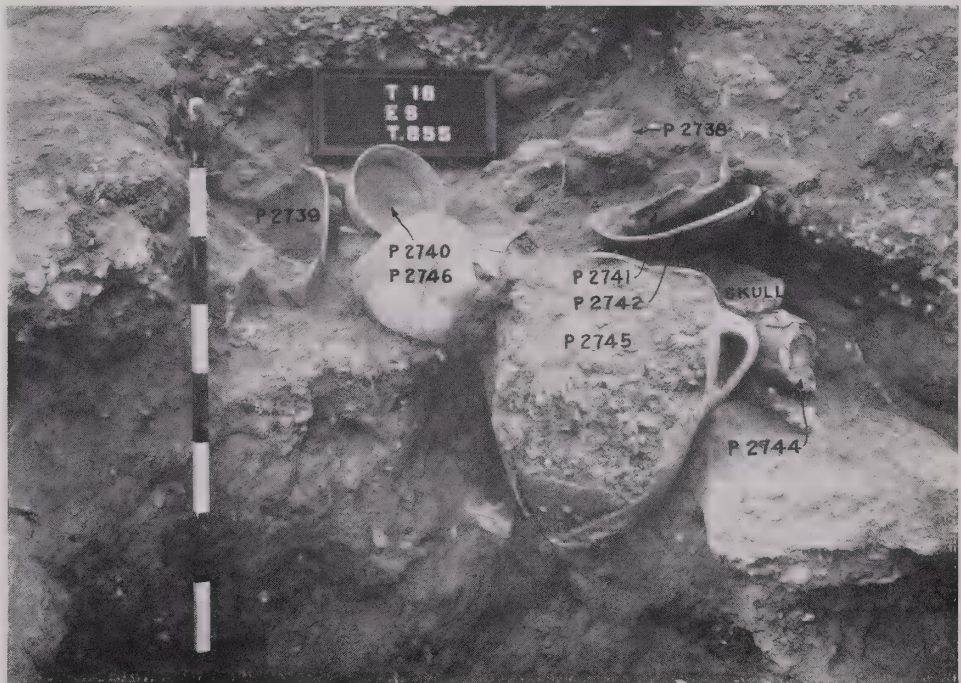

FIG. 102.—TOMB 855 FROM SOUTH AFTER REMOVAL OF POTTERY SHOWN IN FIG. 101

## TOMB 219 IN SQUARE S 16

Tomb, date uncertain; contents, mixed  
 Contents illustrated on Pls. 42-43 and 141

A small chamber (1.9 × 1.2 × 1.4 high) roughly hacked out of the rock. The contents were so mixed in date that no conclusions could be drawn. Only fragments of bone were found.

## TOMBS 855 AND 856 IN SQUARE T 16

LB I

Contents illustrated on Pls. 43-44 and 141-42

Burials in earth débris. Though there is no evidence for it, it is probable that these two groups belonged to the same grave. A layer of limestone chips laid down as the foundation for MI wall 220 (see Pl. 1) extended over the bed of earth débris in which these burials were found. The skeletons lay 40 to 50 cm. above the rock. Much disturbance had taken place (Figs. 100-102). The jaw of one skeleton in T. 855 lay near its feet, and often fragments of the same vessel were widely separated both laterally and in depth. P 2738, the flat base of an EB jar (see Fig. 102), had apparently been dug up from an earlier occupation floor on the rock underneath.

There were two adult skeletons in T. 855, both partly contracted with head to east. One, H 143 (see Fig. 100), lay on its left side, but the other was so broken that its position, though probably similar, was not clear. An infant, contracted, had been buried in the large jar P 2745 (see Fig. 102) with a jug (Pl. 43:31). The skeleton (H 144) in T. 856 (see Figs. 100 and 187:7) lay on its left side with head to west; the legs had completely disappeared, but the position suggests contracted burial.

Before either T. 855 or T. 856 was found, a group of about a dozen pots (not illustrated) had been laid bare about five meters to the southwest of the latter and had been given the ordinary locus number 853 because no bones occurred with it. Since all the forms in this group except a Cypriote bowl with wishbone handle are duplicated among the vessels from T. 855 it is possible that they originally belonged to T. 855-56.

## TOMB 876 IN SQUARE W 16

LB I

Contents illustrated on Pls. 44 and 142

Adult burial in débris, 1.5 below the surface and .2 above the rock. The skeleton was very fragmentary but had apparently been partly contracted. The head lay to north-northwest.

## TOMB 921 IN SQUARE U 16

Tomb, date uncertain; contents, LB I  
 Contents illustrated on Pl. 45

Burials in the filling of a cave (locus 863) which had been in use at a much earlier date. Figure 103 shows the skeleton of a child, partly contracted on left side with head roughly to west, and two jugs (Pl. 45:1 and 3) found with it. Another jug and a lamp (Pl. 45:2 and 4) lay a little to the south with a few fragments of human bones which indicated a second burial.

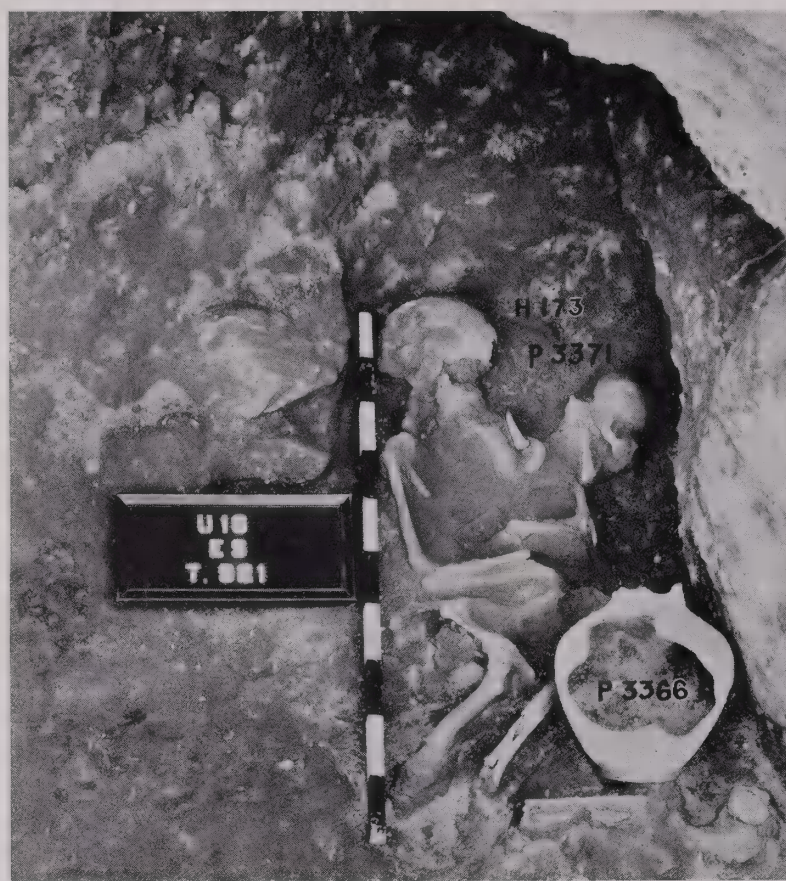

FIG. 103.—TOMB 921 FROM EAST, SHOWING LB I CHILD BURIAL

#### TOMB 1100 IN SQUARE W 16

Tomb, MB I; contents, LB I

Contents illustrated on Pls. 45-48 and 143-49

A shaft tomb (Fig. 104) with the entrances to chambers B, C, and D much wider than usual (cf. Fig. 168). A careful examination was made to see whether they had originally been narrower, but it was impossible to tell. There was no pit in the floor of chamber A. The rock surface was poorly preserved in most places, and no tool marks were visible. Traces of what may have been plaster were observed on the walls of chamber D. The shaft had recessed footholds. It was full of débris, and a considerable quantity had penetrated into chamber A because there was no blocking stone in the entrance. More débris had come in through a hole in the upper southwest corner of chamber D, and rock had fallen from the roof in several places.

When the débris had been cleared, the tomb presented the appearance shown in Figures 105-7. Figures 108-10 show it after the top layer of furniture had been removed.

Disturbance and looting had evidently taken place in antiquity, but it was possible to determine the positions of several of the skeletons, of which there were at least 17 (e.g. Figs. 195-96). In chamber A, at the end opposite the entrance, on a beaten earth floor .2 above the rock, three adults (H 103, H 105, H 111) lay at full length on their backs with heads to west. In chamber D the upper part of one adult, including the skull, was similarly oriented. A fine dagger (Pl. 149:8) lay along its spine. This skeleton must either have been contracted or have had its legs hanging over into chamber A. A few long bones and two other skulls, one of the latter with copper oxide stain on the forehead, were found in D. Chamber B contained only a

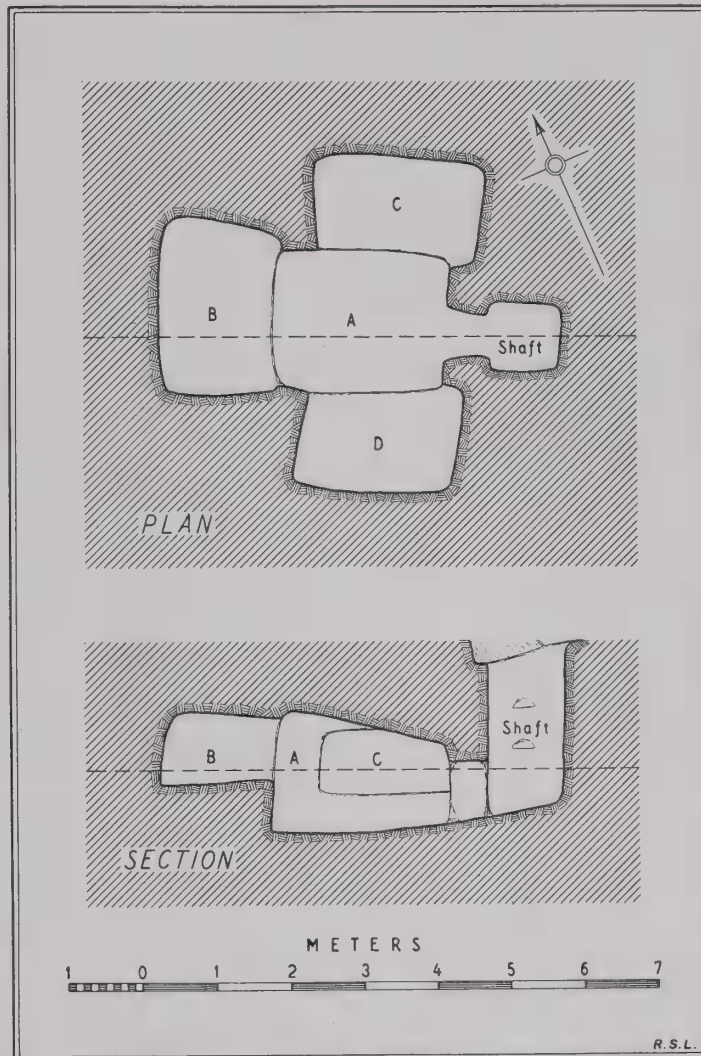

FIG. 104.—PLAN AND SECTION OF TOMB 1100. SCALE, 1:100

few human bones, badly broken and scattered, and there was a small heap of animal bones in the northwest corner. The bones in C had been badly disturbed.

Holes were observed in the walls of all the chambers, but only one (about in the middle of the southwest wall of D) contained anything. In it were two dagger blades (Pl. 149:6-7), with their pommels (Pl. 149:2-3). Both daggers had been intentionally bent double, the smaller within the larger, or "killed" (see p. 137). M. Dunand kindly allows mention to be made of the fact that a gold dagger found by him at Byblos had been similarly bent double.

No particular order could be remarked among the pottery, although some of the vessels were still standing where they had originally been placed. Several small jugs (e.g. Pl. 45:27-34) were found inside larger jugs, jars, and bowls. Small jugs were often found in larger vessels, which had probably contained wine, and were undoubtedly intended for serving.

The tomb produced no MB I pottery whatever, but in spite of this and the slight departure from normal in plan, it seems practically certain that, like the rest of the shaft tombs, T. 1100 was cut during MB I. It is likely that the absence of the original pottery is due to no more than a thorough clearing of the tomb before the LB I burials found in it were made. The pottery from this tomb forms a type group for the LB I period. A developed drawing of the design from a painted jug (Pl. 46:15) appears in Figure 111.



FIG. 105.—TOMB 1100 D FROM NORTH, WITH PART OF CHAMBER A IN FOREGROUND



FIG. 106.—TOMB 1100 A AND B FROM SOUTHEAST

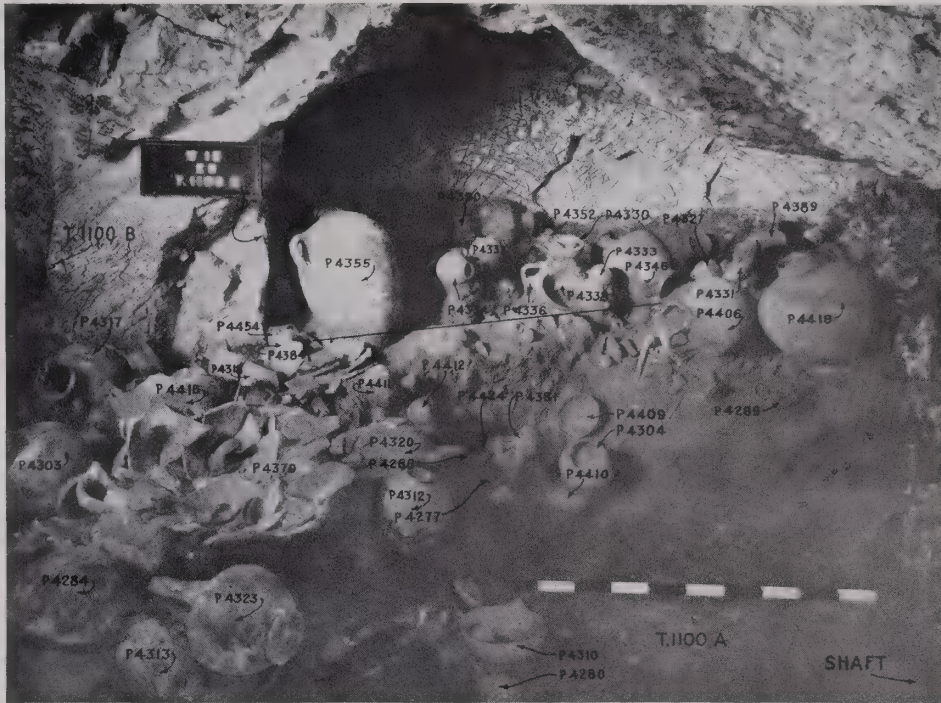

FIG. 107.—TOMB 1100 C FROM SOUTHWEST, WITH PART OF CHAMBER A IN FOREGROUND



FIG. 108.—TOMB 1100 A AND D FROM NORTH AFTER REMOVAL OF REMAINS SHOWN IN FIG. 105



FIG. 109.—TOMB 1100 A, LOOKING NORTH FROM CHAMBER D, AFTER REMOVAL OF REMAINS SHOWN IN FIG. 106



FIG. 110.—TOMB 1100 A AND C FROM SOUTHWEST AFTER REMOVAL OF REMAINS SHOWN IN FIG. 107

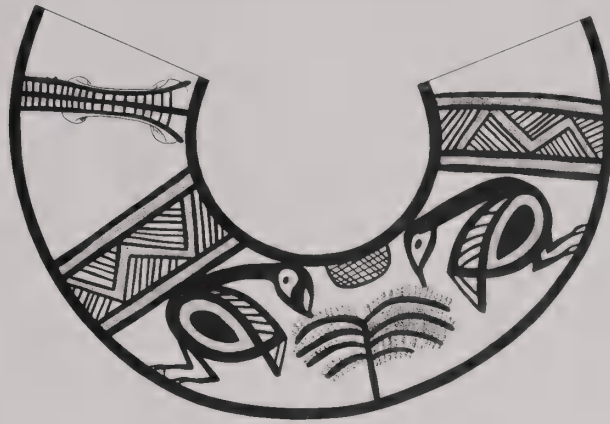

FIG. 111.—DESIGN ON A JUG (= PLS. 46:15 AND 144:3) FROM TOMB 1100 A. SCALE, 1:5

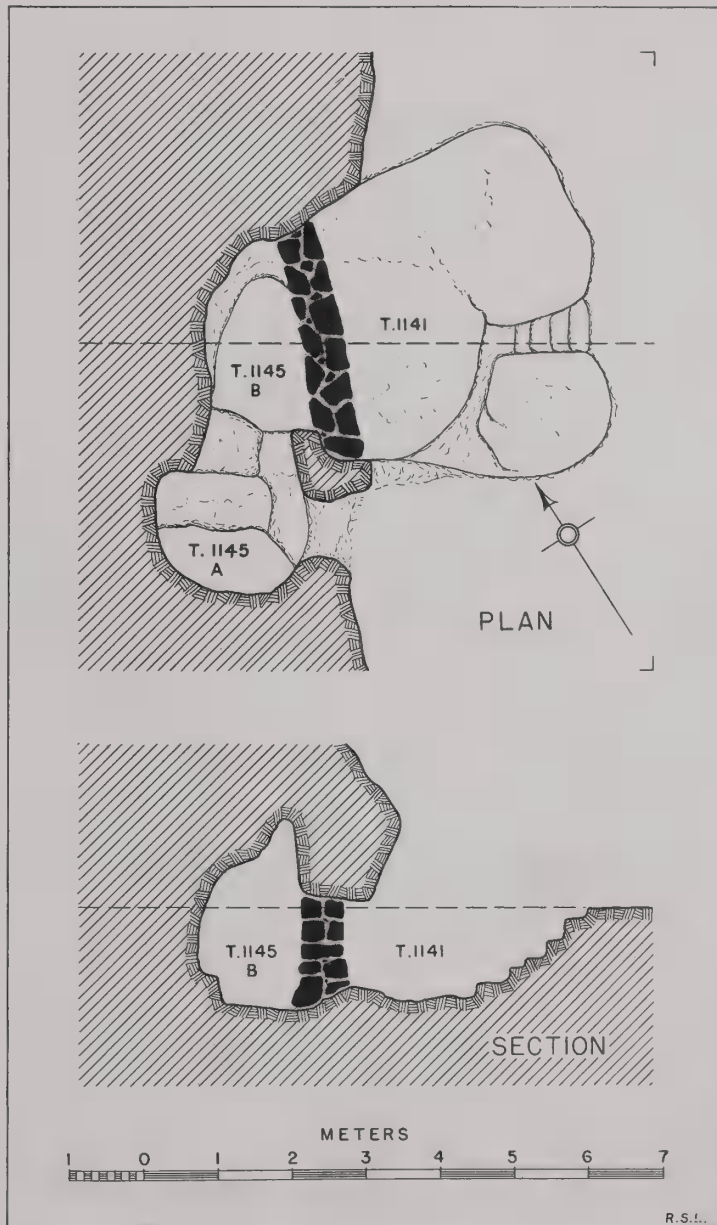

FIG. 112.—PLAN AND SECTION OF TOMBS 1141 AND 1145. SCALE, 1:100

## TOMB 1141 IN SQUARE U 17

Tomb, EB(?); contents, EB (Stages I-IV) and LB I  
 Contents illustrated on Pls. 49 and 150

A rock-cut chamber with two irregular lobes separated by steps on the southeast (Figs. 112-13). Most of the roof had collapsed, and much disturbance had taken place. Indeed it looked as though the middle of the floor had been cleared leaving at the sides only a little filling, which contained the antiquities found. A stone wall separated T. 1141 from T. 1145 B (see Fig. 112), showing that the two had originally formed a single chamber. The presence of two EB pottery vessels (Pl. 49:12-13) suggests that the cutting of this single chamber took place during EB.



FIG. 113.—TOMB 1141, SHOWING SKELETON H 140 (TO RIGHT OF METER STICK) AND POTTERY RESTING ON DÉBRIS AGAINST WALL BETWEEN TOMBS 1141 AND 1145 B

The only skeleton found in T. 1141 lay in the northeast corner, fully contracted on right side with head to west. There was no pottery near it. It is likely that it belonged to the early occupation and had nothing to do with the LB I furniture, which was found at a higher level chiefly in the northwest corner and against the stone wall. This wall was evidently built at the time when the LB I burials were made in T. 1145 B, and the LB I pottery found in T. 1141 may be considered as belonging to those burials.

## TOMB 1145 IN SQUARE U 17

Tomb, EB(?); contents, EB (Stages I-IV) and LB I  
 Contents illustrated on Pls. 49-52 and 150-52

A rock-cut tomb with two chambers (see Fig. 112) separated by a rock partition and stone blocking resting upon it. The blocking was intact (Fig. 114), as was the stone wall between

chamber B and T. 1141. Thus chamber B was undisturbed, but A may have been entered in antiquity after the furniture had been deposited. No skeletal remains were found in A, which seems to have been reserved exclusively for offerings (Figs. 115-16).

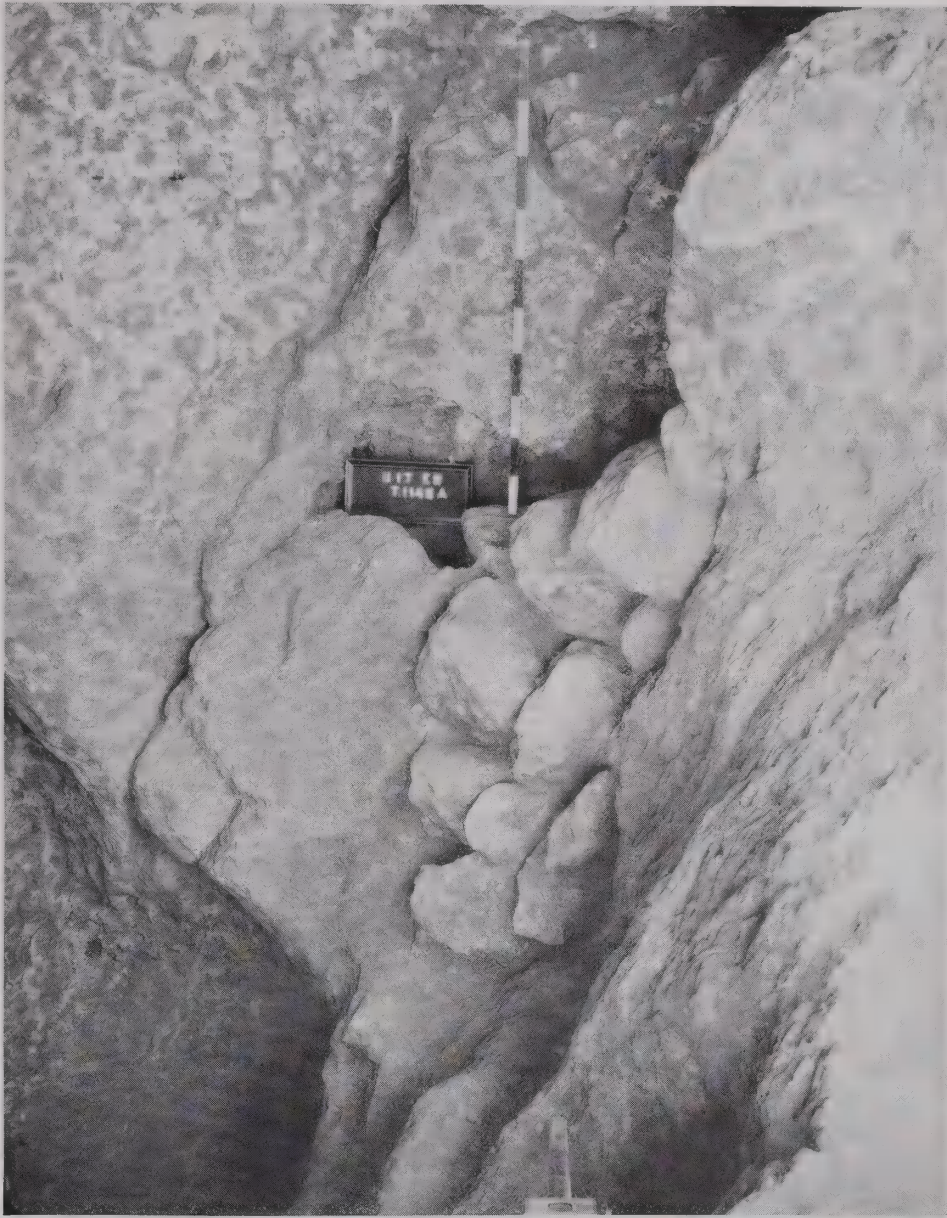

FIG. 114.—TOMB 1145 FROM SOUTHEAST, SHOWING BLOCKING WALL BETWEEN CHAMBERS A AND B

The LB I burials in B provided a single group (Figs. 117-19) apparently put in at one time. Nine human skeletons (H 130-38) were found (Fig. 120), six (five adults and one infant) lying on the right side, one on the left, and two on the back. All except the two on their backs were either contracted or partly contracted, and all headed north. The skeleton of a small sheep or goat lay opposite H 137. The skeletons were low in the tomb, with a little of the pottery at the same level, but most of it piled on top of them.



FIG. 115.—TOMB 1145 A FROM NORTHEAST



FIG. 116.—TOMB 1145 A FROM NORTHEAST AFTER REMOVAL OF POTTERY SHOWN IN FIG. 115

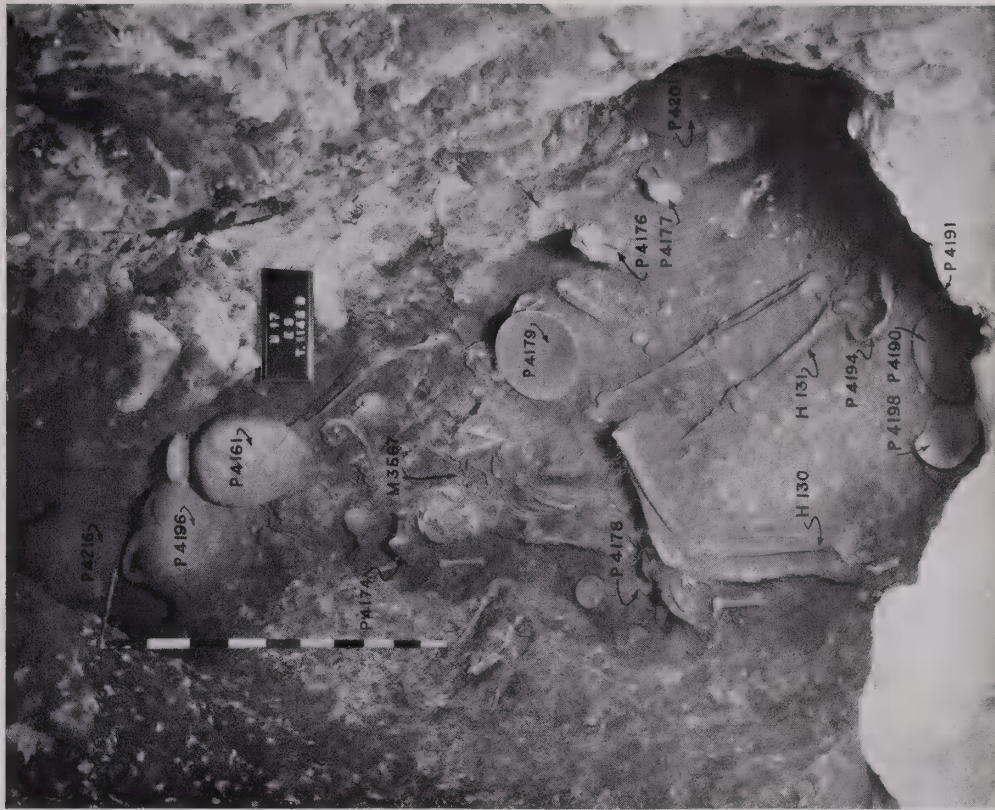

FIG. 118.—TOMB 1145 B FROM SOUTHWEST, SHOWING SKELETAL REMAINS AND LB I OBJECTS FOUND AFTER REMOVAL OF POTTERY SHOWN IN FIG. 117



FIG. 117.—TOMB 1145 B FROM SOUTHWEST, SHOWING SKELETAL REMAINS AND LB I POTTERY, WITH BLOCKING WALL BETWEEN TOMBS 1145 B AND 1141 VISIBLE AT RIGHT

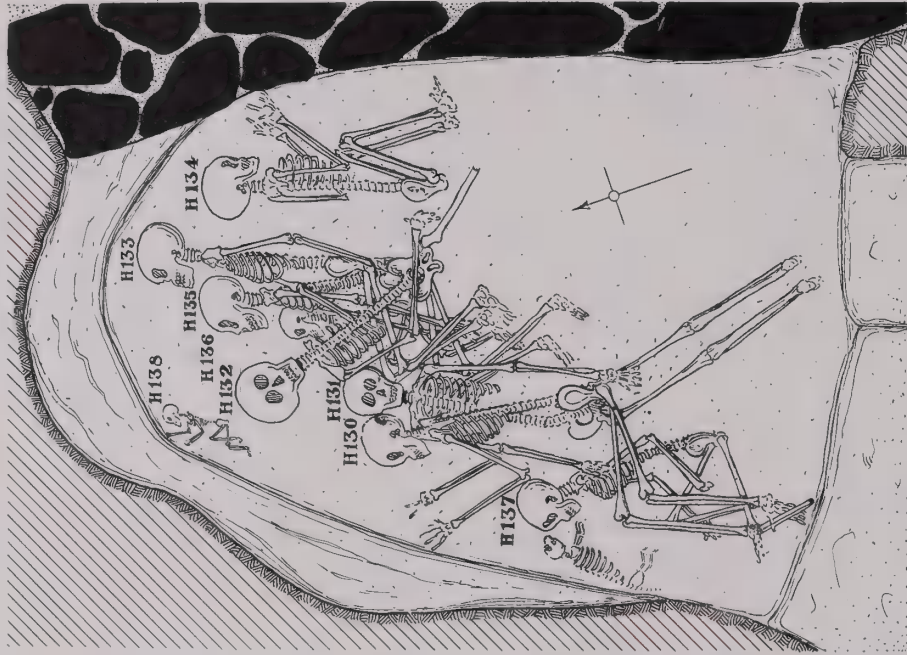

FIG. 120.—SCHEMATIC DRAWING OF SKELETONS IN Tomb 1145 B. SCALE, 1:20



FIG. 119.—Tomb 1145 B FROM SOUTHWEST AFTER REMOVAL OF REMAINS SHOWN IN FIG. 118

Several flat bases and hole-mouth rims of EB pottery found under the burials in B and obviously having nothing to do with them probably belonged with the EB deposit in T. 1141 and suggest the date of cutting.



FIG. 121.—TOMB 1178 FROM NORTHEAST

TOMB 1178 IN SQUARE U 17

LB I

Contents illustrated on Pls. 53 and 152

A pit in the rock with a low wall of rough stones along the northeast. The skeletons, an adult (H 142) and a child (H 141; see Fig. 187:6), were partly contracted on right side with heads to south. An animal—a lamb or a kid—had been buried between them (Fig. 121). It was prob-

ably an offering, but pets are not unknown in antiquity. Two "bronze" plaques (Pl. 152: 18-19) were found with H 142, one under the face, the other under the right collarbone.

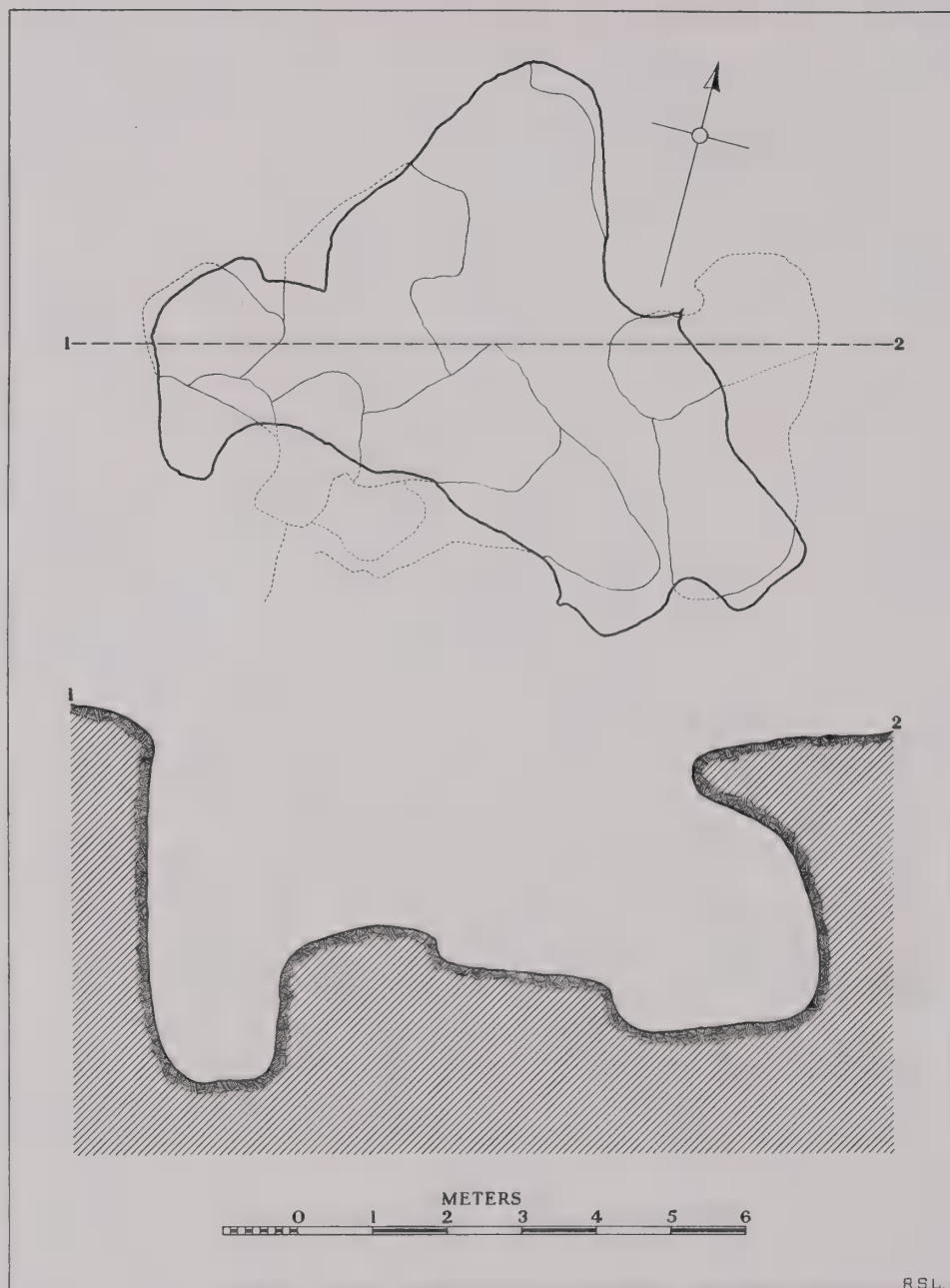

FIG. 122.—PLAN AND SECTION OF TOMB 4. SCALE, 1:100

#### TOMB 1 IN SQUARE S 20

Tomb, date uncertain; contents, mostly LB II  
Contents illustrated on Pl. 153

A cave in the rock. The entrance had been greatly damaged by deep quarrying. Due to fissures in the poor limestone excavation was abandoned before the entire plan and contents

could be recovered. Among the pottery (see opp. Pl. 153) were two Cypriote milk bowls and a bilbil.

#### TOMB 2 IN SQUARES R-S 19-20

Tomb, date uncertain; contents, LB II

Contents illustrated on Pl. 153

A rock-cut chamber originally entered from above. The interior was filled to the top of the entrance with a fine silt washed in by many seasons of heavy rainfall when the door was still open to the sky. Below this was a stratum of coarser débris mixed with stone chips and numerous fragments of LB II pottery (see opp. Pl. 153), and over the rock floor was an irregular bed of limestone chippings. There were abundant chisel marks on the walls and ceiling. The cave might have been originally occupied as a dwelling and then during LB II remodeled and used as a burial place. At that time perhaps it had been cleared out and enlarged and given a more regular shape, the roughness of the walls dressed down, and the bed of chips spread over the floor to even up its irregularities. The pottery and a few other objects, apparently scattered by late plunderers, were all that was left of the funerary equipment.

#### TOMB 4 IN SQUARE R 18

Tomb, date uncertain; contents, EB, LB I and II

Contents illustrated on Pls. 54-56 and 153

An irregular cave in the rock (Fig. 122) with entrance at the east. The roof had collapsed. T. 4 and T. 3 (see p. 72) were joined by a rough break. A "bronze" statuette of Reshef (Pl. 153:8),<sup>18</sup> wearing a cap and a wide girdle, is the most interesting object among the greatly disturbed contents of T. 4. An arrowhead (Pl. 153:9) had been intentionally bent or "killed."

#### TOMB 8 IN SQUARE U 19

Contents, MB II and LB II

Contents illustrated on Pls. 56 and 153

T. 8 (see Fig. 49) seems to have been not so much a burial place in itself as a repository for material, all pottery, discarded from T. 24 by looters (Fig. 123). It had been a spot worked intensively by quarrymen who eventually broke through into T. 24. As one might expect in view of the conditions found in T. 24 (see p. 48) most of the pottery in T. 8 was LB II, including a milk bowl (Pl. 56:3) and painted bilbils (Pl. 56:7-8) of the Cypriote base-ring class and a Mycenaean flask (Pl. 56:9). The MB II layer in T. 24 was represented in T. 8 by two pieces of pottery only (e.g. Pl. 56:5).



FIG. 123.—TOMB 8, WITH LB II POTTERY

#### TOMB 13 IN SQUARE V 19

Tomb, date uncertain; contents, mixed

Contents illustrated on Pl. 154

A cave with collapsed roof and much of its contour destroyed. There remained only a series of irregular cavities which may have represented chambers. The entrance was perhaps at the

<sup>18</sup> Erroneously attributed to T. 3 in *OIC* No. 4, p. 43.

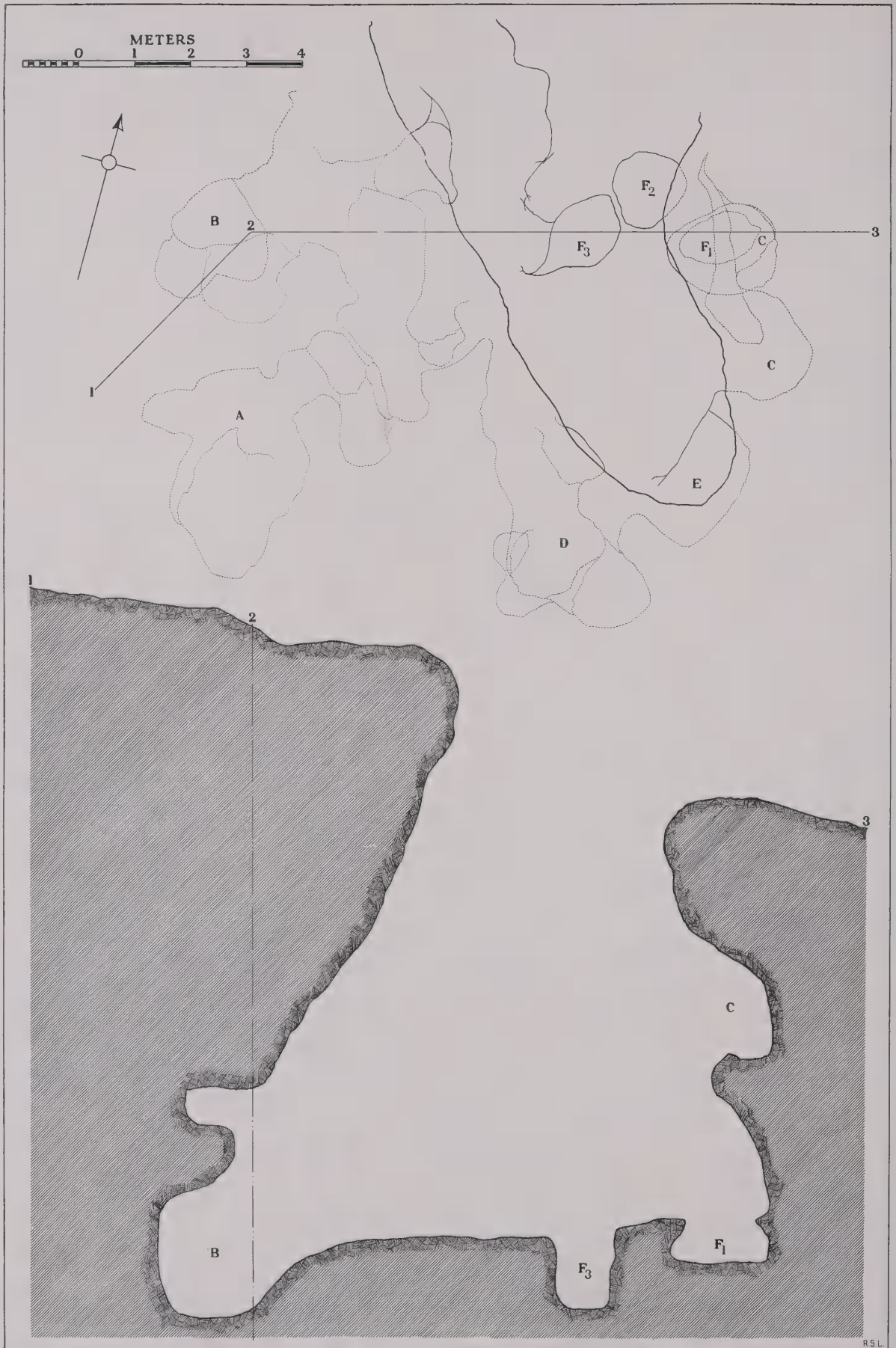

FIG. 124.—PLAN AND SECTION OF TOMB 26. SCALE, 1:100

west. From openings in the rock around the tomb came masses of broken pottery of diverse periods (not illustrated), some of which had probably been thrown out when the tomb was looted. It seemed clear, however, that much more than T. 13 material was represented in these dumps. The refuse may have accumulated from several tombs or even from the town on the tell. What little pottery there was in the tomb proper is LB II (see opp. Pl. 154).

#### TOMB 25 IN SQUARE V 19

Tomb, date uncertain; contents, LB II  
Contents illustrated on Pl. 57

A roughly circular cave entered from above. A number of side chambers, apparently not cut purposely, were ranged around the main chamber. The skeletal material consisted of two adult skulls (H 179-80) completely dissociated from a pair of adult legs and some toes found elsewhere in the tomb. The disorder among the bones and pottery and the complete lack of small objects indicate that the tomb had been rifled.

#### TOMB 26 IN SQUARE V 18

Tomb, date uncertain; contents, LB I and LB II  
Contents illustrated on Pls. 57-59 and 154-55

A deep cave in the rock with many chambers and alcoves (Fig. 124). Quite clearly it had been investigated in antiquity. A group of pottery which had apparently been thrown out and mixed with bones (Fig. 125) was the first indication that a tomb was in the vicinity. The only undisturbed objects were seven pieces of LB II pottery (see Fig. 125)—a bowl (Pl. 58:3) and six pilgrim flasks (e.g. Pl. 154:3). Most of the roof had collapsed (Fig. 126), and to safeguard the workers it was necessary to break down jagged pieces that were still in place. Huge pieces of limestone lay in the débris, many of them bearing cupmarks such as were found over the entire east slope.

Of special interest among the pottery vessels are some unpainted jars (e.g. Pls. 57:9-10 and 154:6) similar in form to many found at Tell el-Amarnah (see p. 155). Chamber A produced the greatest quantity of pottery. That from chambers C<sup>19</sup> and G<sup>20</sup> is not illustrated because it is duplicated by specimens shown elsewhere in the volume. Two basalt grinders (Nos. 601 and 603) from T. 26 are shown in Figure 127.

#### TOMB 28 IN SQUARE V 18

Tomb, date uncertain; contents, LB II

A cave in the rock. The roof had collapsed and fallen on a LB II burial and two later kilns. The pottery is not illustrated because most of it is duplicated by specimens shown elsewhere in the volume.<sup>21</sup>

<sup>19</sup> x 3339-40, LB II jugs (cf. Pl. 59:15).

<sup>20</sup> x 3-4, LB I jugs (cf. Pl. 58:15)

x 7, LB I bowl (cf. Pl. 59:2)

x 8, LB II bowl (cf. Pl. 58:6)

x 1045-46, LB I lamps (cf. Pl. 154:20)

x 3348-49, LB I jugs (cf. Pl. 58:20).

<sup>21</sup> x 8-9 and x 47, bowls, brown ocher 3 (cf. Pl. 54:5)

x 10, bowl, burnt umber 3 (cf. Pl. 59:5)

x 11, jar, some light grits, burnt umber 3 core, indian red 3 surface (cf. Pl. 56:11)

x 19, jar, indian red 3 (cf. Pl. 56:10)

x 29 and x 2921, jugs, permanent brown 3 core, naples yellow 3 surface (cf. Pl. 65:26)

x 31, bowl (cf. Pl. 54:7)

x 35, bowl, charcoal gray 1 core, burnt umber 3 surface (cf. Pl. 57:5)

x 48, jar, light red 1

x 2923, flask (cf. Pl. 154:3)

x 7106, jar, d. .83, charcoal gray 1.



FIG. 125.—TOMB 26, SHOWING UNDISTURBED LB II POTTERY IN FOREGROUND



FIG. 126.—VERTICAL SHAFT AND ENTRANCE OF TOMB 39 AS EXPOSED BY COLLAPSE OF SURFACE ROCK INTO TOMBS 26 AND 40

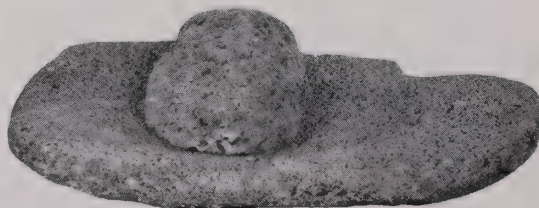

FIG. 127.—BASALT GRINDERS (x 601 WITH x 603 ON TOP) FROM TOMB 26. SCALE, 1:5

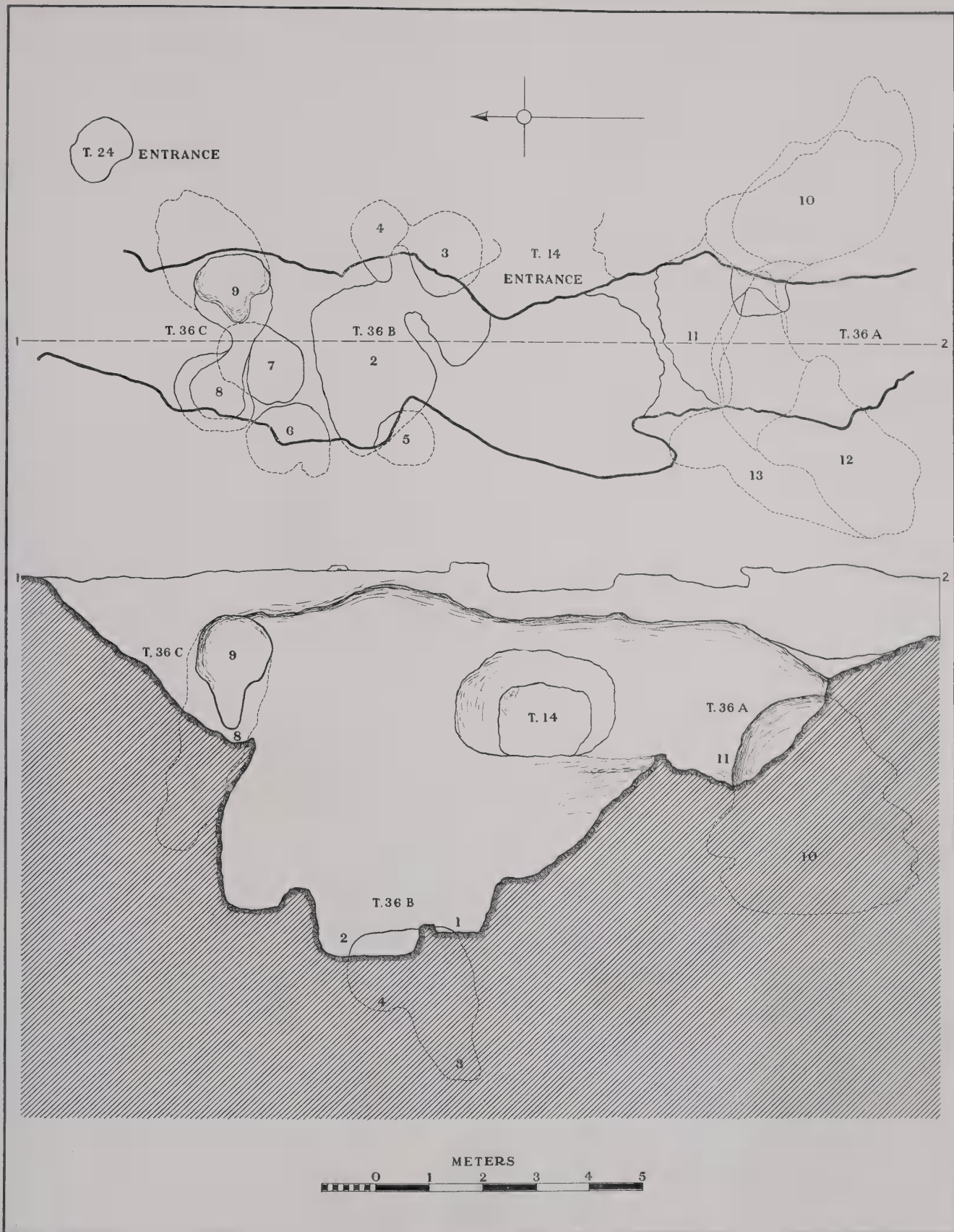

FIG. 128.—PLAN AND SECTION OF TOMB 36. SCALE, 1:100

## TOMB 31 IN SQUARE V 19

Tomb, date uncertain; contents, mixed  
Contents illustrated on Pl. 156

A deep cave with entrance probably at the west. The pottery (not illustrated) was in considerable disorder but could be identified as EB (Stages I-IV), LB I, LB II, and MI.

## TOMB 36 IN SQUARES U-V 19

Tomb, date uncertain; contents, chiefly LB II  
Contents illustrated on Pls. 59 and 156

A cave in the rock (Fig. 128). The entire rock surface was very irregular. The floor, which had been cut down in antiquity, consisted of deep and rough cavities. It is possible that they were made in the process of quarrying limestone to be ground up for floors of early habitations near by.

The pottery from A (not illustrated) is mixed in date, that from B is principally LB II with some LB I sherds, and C yielded only a few sherds (not illustrated). Several well preserved adult skulls (H 181-85; see Fig. 197) and long bones, in no burial order, came from B but in view of the general confusion cannot be dated. An unusual type of decoration is found on one of the LB II bowls (Pl 59:8) from B.

## TOMB 40 IN SQUARES U-V 18

Tomb, date uncertain; contents, LB  
Contents illustrated on Pls. 59 and 156

A very large cave, with the roof completely collapsed (see Fig. 126). Because of the great rock movements that had taken place it was impossible to get an accurate idea of the original plan. All of the contents had been disturbed. Most of the pottery was of the LB II period, but there were a few LB I sherds (not illustrated).

## TOMB 48

Tomb, date uncertain; contents, LB II  
Contents illustrated on Pls. 59-60 and 156

All the contents had been disturbed. A large jar (Pl. 59:18), a decorated chalice (Pl. 60:5), and two curious funnels (Pl. 156:17-18) are unusual for the LB II period.

## TOMB 59 IN SQUARES S 17-18

Tomb, date uncertain; contents, mixed  
Contents illustrated on Pl. 157

A very large cave with a broad antechamber and two entrances (Figs. 129-30). The entrances lay about five meters to the north of the opening to T. 63 (see below), and in one place the two caves almost met. They had several features in common—great size, irregular interior cutting and outline, pits in the floor, same periods of occupation—all pointing to similar usages by contemporaries.

A wall fragment (at right in Fig. 129) extending northeast from the south end of the antechamber was probably part of a larger structure used at a time when the cave had purposes other than those of burial. Two large, well cut limestone blocks standing against the bedrock pillar which separated the entrances to the cave may have been remains of an original blocking of the tomb. Pits sunk in the floor may have been for storage, but except for A, B, D, and E they yielded practically nothing. From them came, in addition to the objects illustrated, a quantity of LB II vessels, including some Cypriote types, and a few EI and MI pieces. C and E extended under the floor of the cave. The entrance to E was an oval hole with greatest

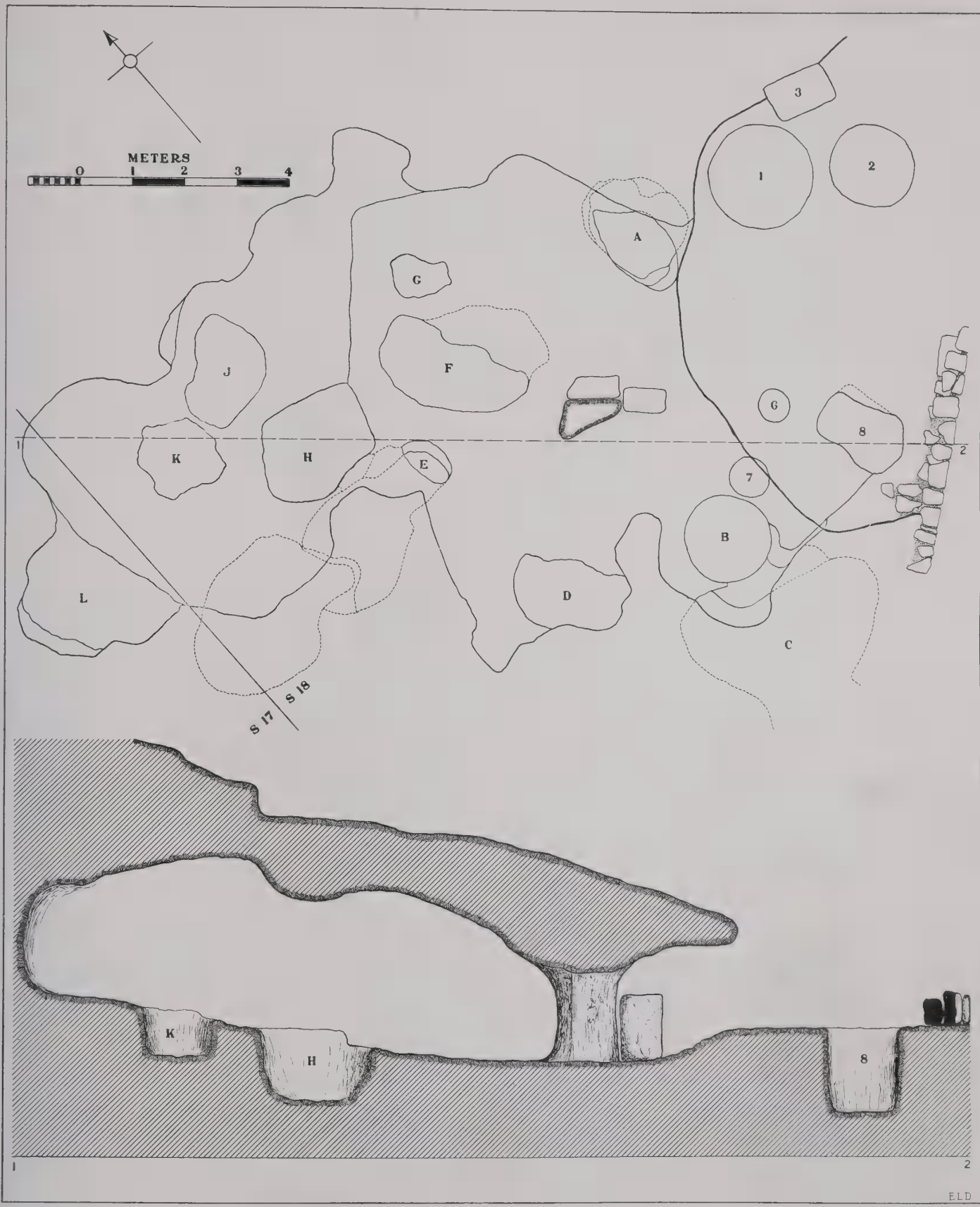

FIG. 129.—PLAN AND SECTION OF TOMB 59. SCALE, 1:100

diameter of only about a meter. Practically no human bones were found, but the predominance of LB II pottery and comparison with T. 63 suggest that the real burial period was LB II.



FIG. 130.—ENTRANCES TO TOMB 59



FIG. 131.—TOMB 64 AND ENTRANCE TO TOMB 63, SHOWING STONES BLOCKING HOLE FROM TOMB 64 INTO TOMB 63

#### TOMB 63 IN SQUARES S-T 17-18

Tomb, date uncertain; contents, mixed

Contents illustrated on Pls. 60-63 and 158

A cave in the rock. A short approach and a well cut doorway (Fig. 131), 1.5 in width and slightly more in height, led to a well cut chamber. The west and south walls had for the most

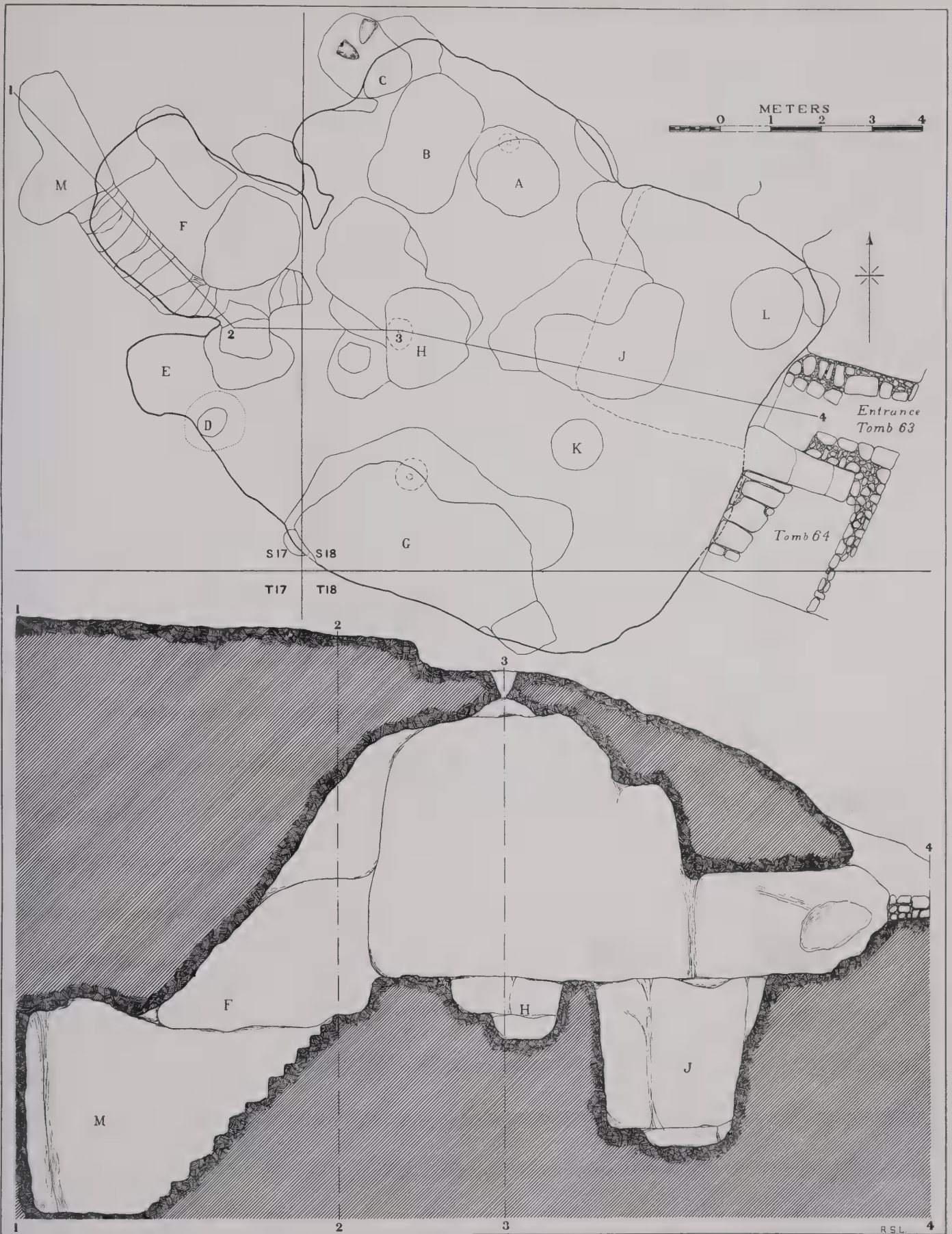

FIG. 132.—PLAN AND SECTION OF TOMB 63 AND PLAN OF TOMB 64. SCALE, 1:100

part been destroyed, but enough of these remained near the roof to permit them to be dotted in on the plan (Fig. 132). Figure 133 shows the northwest corner with the outlines at the roof emphasized in ink. This chamber was the original tomb. Its doorway had presumably been blocked and concealed by those who made it. Subsequently the chamber was broken into from a point which later formed the northwest wall of T. 64 (dotted in Fig. 132). The doorway must have been discovered from the inside. This was apparently unblocked and used, while the hole just made was closed with large stones (see Fig. 131). Then the rest of the cave was roughly hacked out until, as we found it, it measured some fourteen meters by ten, with the roof from two to five meters above the floor. Débris had filtered in through the doorway and through three holes in the roof (dotted in Fig. 132) until, when it was discovered, it was scarcely possible for a man to crawl between filling and roof.



FIG. 133.—TOMB 63, LOOKING WEST-NORTHWEST FROM ENTRANCE. BROKEN LINES INDICATE UPPER NORTHWEST CORNER OF ORIGINAL TOMB CHAMBER

Pits in the floor (A, B, C, D, G, H, J, K, L; see Fig. 132), varying from about half a meter to three and a half meters in depth, were perhaps for storage. D was a small bottle-shaped pit, the mouth of which could have been closed by a stone slab and concealed. It is possible also that some of the pits were quarries. Once one has penetrated below the surface of the rock at Megiddo it is quite soft and easily worked, and at all periods down to the present day it has been quarried out and used for making plaster. Numerous shapeless and otherwise inexplicable holes in the rock of the east slope are probably places from which stone has been taken for this purpose. E and F are perhaps to be considered as belonging to the stairs between them and to chamber M, though the latter two were unproductive. E was the only place in which human bones were found. These included part of a jaw, several arm and leg bones, and a few smaller bones. They were in no sort of order.

The pottery illustrated under the heading "Tomb 63" (see Pl. 60) is not from any of the sub-loci mentioned above. It includes three bowls (Pl. 60:9-10 and 12) which resemble bowls

found in E–MI context on the tell and an E–MI bowl (Pl. 75:8) from T. 80 C. There is, however, in the museum of the American University at Beirut a vessel very like No. 5520 (Pl. 60:12). It was found at Sarafand, between Tyre and Sidon, in a tomb which otherwise produced nothing but LB II pottery, including stirrup cups like P 27 and P 28 (Pl. 62:20–21) from T. 63 E. Seven MI storage jars (e.g. Pl. 60:17) found together on the floor east of G indicate a definite use of the cave at that time.

The MI jug No. 3701 (Pl. 60:31) and fragments of nine similar jugs were found in A. See note on Nos. 3884–85 from F.

A pottery fragment from B (Pl. 158:3) is almost certainly part of an object similar to a LB specimen found by Schaeffer at Minet el-Beida<sup>22</sup>, the harbor city of Ras Shamra.<sup>22</sup> He refers to an analogue from the acropolis at Mycenae.<sup>23</sup> Others have lately been found by Hamilton at Tell Abu Hawam, near Haifa, in the LB levels.<sup>24</sup> The complete object is more or less ladle shaped. The long flat handle has a hole at the top, apparently meant for hanging it from a wall peg. It might have been a wall lamp. In our specimen the cup of the “ladle” has been broken from the left end, where its beginnings can be seen in the photograph, and the part with the hole is missing from the right end.

The absence of cross lines on a Cypriote milk bowl (Pl. 62:9) from E suggests that it is a late example, made after the checked pattern typical of such vessels (e.g. Pl. 67:2) had lost its significance. It was Petrie who first drew attention to the origin of this design.<sup>25</sup> Two Mycenaean stirrup cups from E (Pl. 62:20–21) have been examined by Pendlebury and dated between 1350 and 1250 B.C.

Much of the pottery from F is LB II. Fragments of fourteen black jugs similar to Nos. 3884–85 (Pl. 63:6–7) and found with them are dated E–MI on the basis of evidence from the tell<sup>26</sup> and from Tell Beit Mirsim.<sup>27</sup> Similar jugs from the early “Seti I” and “Ramses II” levels at Beisan<sup>28</sup> were probably intrusive.

With the exception of three intrusive Chalcolithic and EB fragments (Pl. 60:26–27 and 37) no pottery earlier than LB II occurred in T. 63. It is a fair presumption that the original tomb chamber was LB II or earlier, even though no pottery that early was found in it, since it was in existence before the rest of the cave (see p. 110), which contained quantities of LB II pottery. The high proportion of LB II pottery found with the human remains in E and the nature of this pottery seem to show that E was used as a burial place during that period. The fact that similar pottery was found in almost every other sub-locus suggests that the whole of the cave was so used at the same time. The two Mycenaean stirrup cups from E (see above) tend to narrow the dating limits to between 1350 and 1250 B.C. The Iron Age also was fairly well represented, but some of the pottery suggests that the MI occupation was domestic rather than funerary.

#### TOMB 73 IN SQUARE S 17

Tomb, date uncertain; contents, LB I, LB II, and Iron Age  
Contents illustrated on Pls. 64–66 and 159–63

A great irregular cave in the rock (Fig. 134), with a length of some eighteen meters (north and south) and a maximum breadth of about ten meters. Part of the roof had been quarried away, probably during MI when much stone was needed for rebuilding the city, but eight or nine meters of it remained over the middle of the cave (Fig. 135). When the ground was leveled

<sup>22</sup> *Syria X* (1929) 288 and Fig. 3.

<sup>25</sup> *Tell el Hesi* (London, 1891) p. 45.

<sup>23</sup> *Ibid.* p. 288.

<sup>26</sup> Cf. *OIP XLII*, Pl. 5, Nos. 124–27.

<sup>24</sup> E.g. *QDAP IV* (1934/35) 37, No. 228.

<sup>27</sup> Albright, *AASOR XII* (1932) §§ 94 and 113.

<sup>28</sup> FitzGerald, *Beth-Shan Pottery*, Pls. XLIV 31 and XLVIII 14.

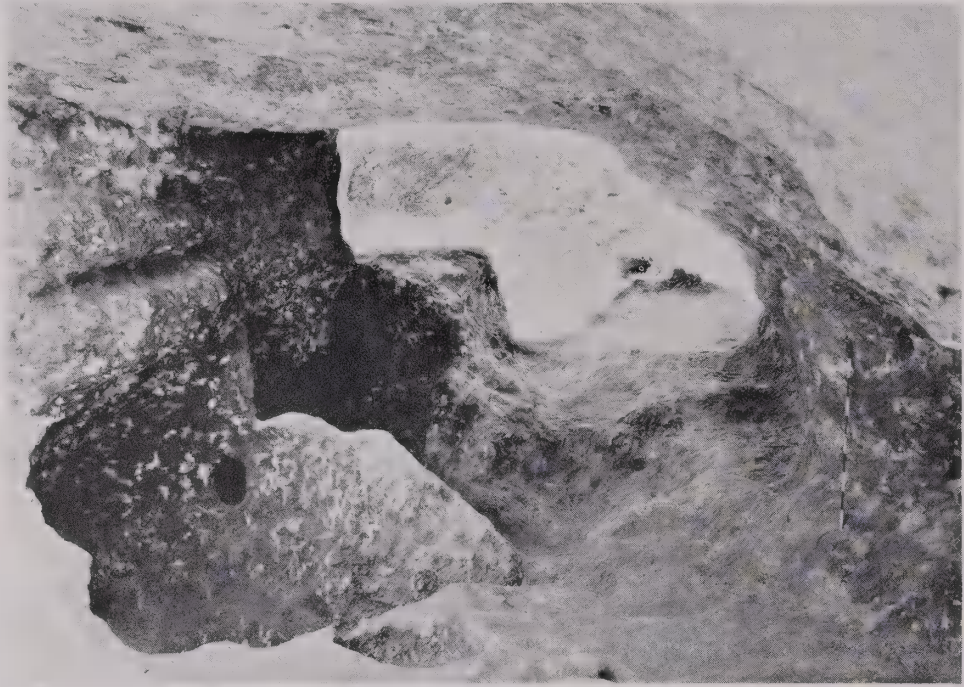

FIG. 134.—TOMB 73 FROM SOUTH



FIG. 135.—TOMB 73 FROM NORTH-NORTHEAST, SHOWING REMAINS OF ROOF AND WALL 220

for the construction of the MI wall 220 (see Pl. 1), which ran close to the northern end of the cave and higher (see Fig. 135), T. 73 was filled with débris. But even prior to this filling the tomb had been much disturbed. No skulls were found, and such human bones as remained were so few and fragmentary that it was impossible to estimate the number of skeletons or their positions. This and the fact that parts of most of the pottery vessels were missing show

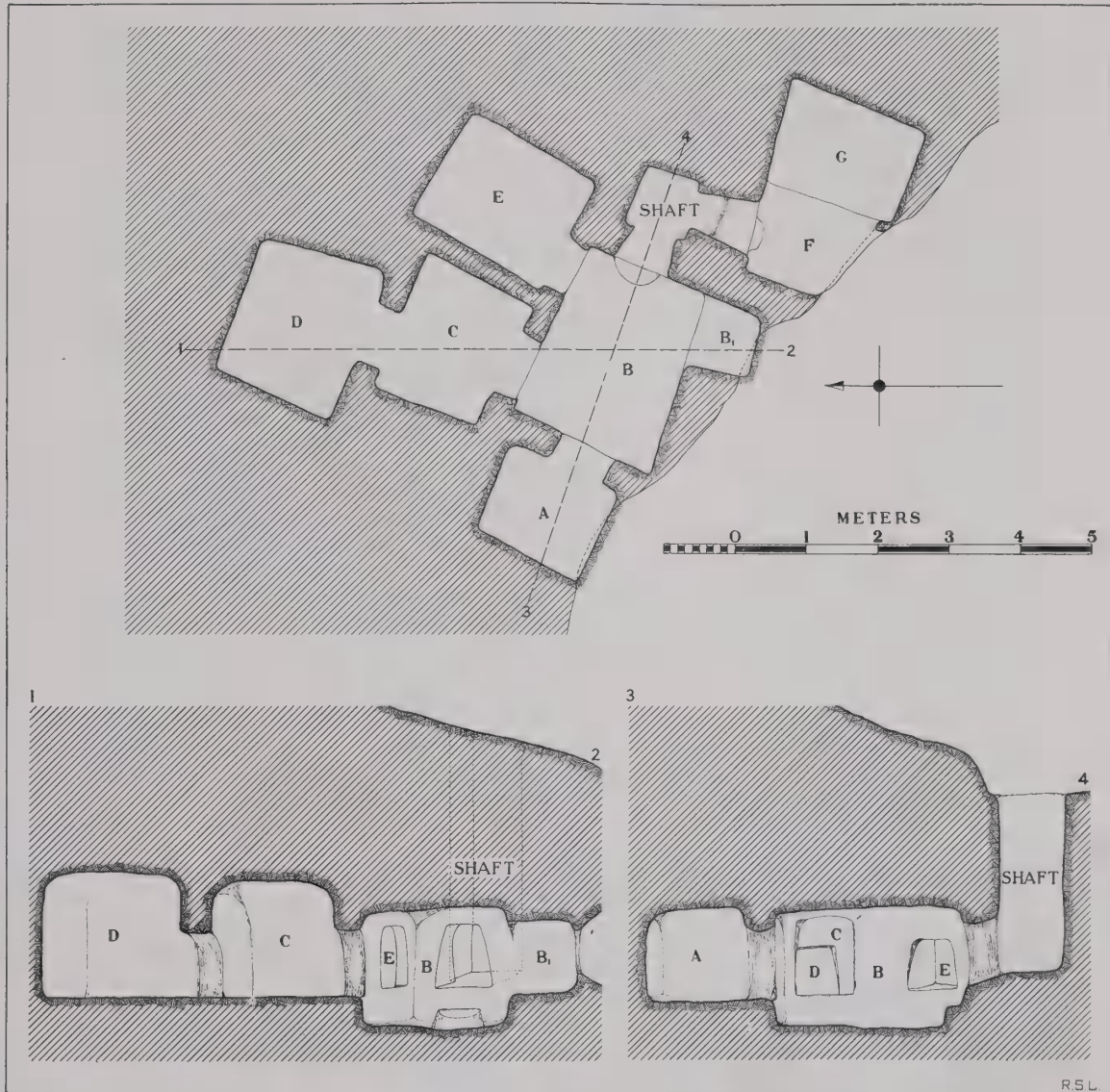

FIG. 136.—PLAN AND SECTIONS OF TOMB 84. SCALE, 1:100

that some of the original contents had been cleared out before the filling was put in. There is nothing to show that T. 73 was excavated before LB, when it was used as a tomb. There must have been several successive burials during that period. The forms of the later Iron Age vessels indicate a domestic occupation. In view of the disturbance the other objects cannot be dated by their pottery context.

The form of bowl P 104 (Pl. 64:28) is Mycenaean, but the ware seems hardly good enough for a genuine specimen. The ware of bowl No. 4170 (Pl. 64:31) is local LB, but the form is

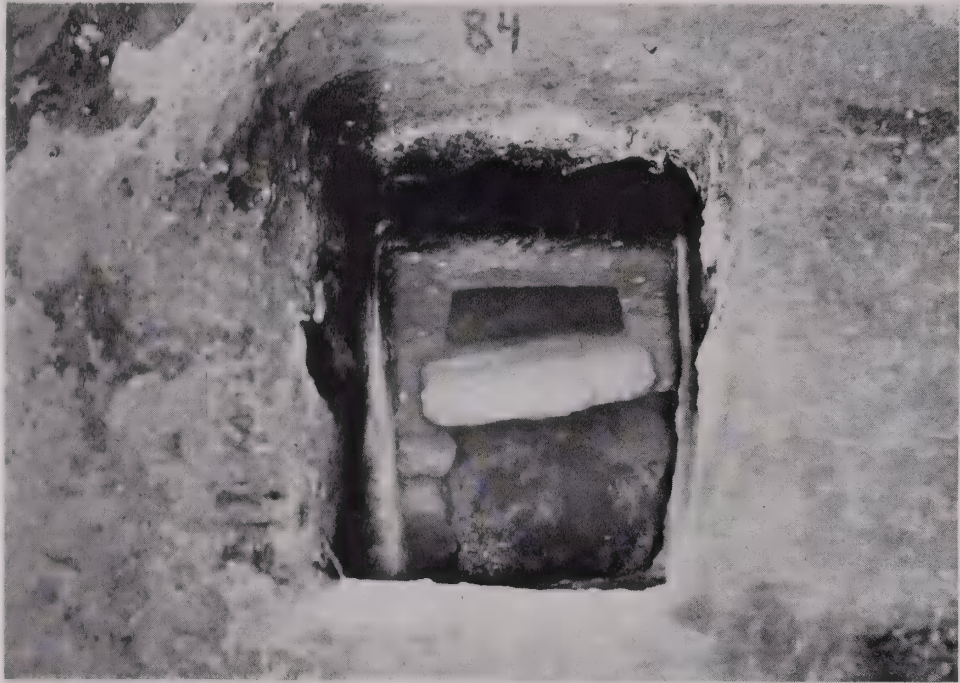

FIG. 137.—SHAFT OF TOMB 84, SHOWING BLOCKING STONE AT BOTTOM



FIG. 138.—TOMB 84 B

unusual. It may be a copy of a Cypriote milk bowl (cf. Pl. 64:30). Sherd No. 4257 (Pl. 160:3) is unusual for Megiddo. Both colors of the decoration can be rubbed off with the finger. The ware looks later than true LB, and the decoration suggests "Philistine" connections. Petrie illustrates a sherd with scales and dots found in 20th dynasty context.<sup>29</sup> Compare also our Plate 8:1 and a sherd from the Third Semitic period at Gezer.<sup>30</sup> The color of P 101 (Pl. 160:25) is duller than is usual for such Cypriote "handle-ridge" jugs.



FIG. 139.—TOMB 84, LOOKING NORTH FROM CHAMBER B

#### TOMB 84 IN SQUARE T 18

Tomb, MB I; contents, date uncertain  
Contents illustrated on Pl. 163

A shaft tomb with numerous chambers (Fig. 136). The nature of the shaft and the general appearance of the chambers lead to the belief that like normal shaft tombs (cf. Fig. 168) it was cut during MB I. The shaft was filled with stones to within 60 cm. of the top. It had once been filled almost flush, and the filling covered with white lime plaster, traces of which can be seen in Figure 137. This plaster looks very like the rock and when intact would help to prevent the shaft from being discovered. The entrance from the shaft to chamber B was blocked by a large stone (see Fig. 137); that from the shaft to chamber F had several smaller stones in it. The walls of the chambers were well cut (Figs. 138-39) by means of metal tools, the marks of which were .012 to .040 wide. Entrance to the tomb had been gained in antiquity through holes from T. 82 (see Pl. 1) into A, B<sub>1</sub>, and F, and through these holes débris had penetrated into these chambers. Otherwise the tomb had no filling in it and had the appearance of having been cleared out. The only things found were some "bronzes" in B and C and a double handful of human bones.

<sup>29</sup> Petrie, *Gerar* (London, 1928) Pl. LXIV 63.

<sup>30</sup> Macalister, *Gezer* III, Pl. CLXV 4.

## TOMB 1250 IN SQUARE JJ 21 (SEE Fig. 2)

LB II

Contents illustrated on Pl. 67

A pit in the rock (Fig. 140). It lay outside the Megiddo Expedition's ground, some four hundred meters to the southeast of the base of the tell. It was revealed during the construc-

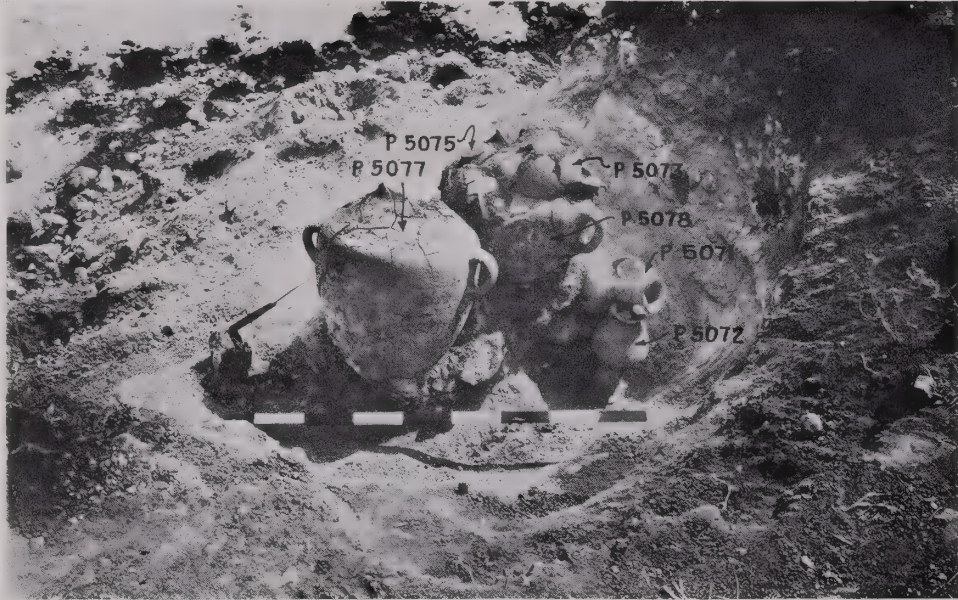

FIG. 140.—TOMB 1250 FROM SOUTHWEST, SHOWING LB II POTTERY

tion, by Government, of the road to Jenin, and the pottery was salvaged by us. Though we found no bones, the group is certainly funerary. The whitewashing of pottery (see Pl. 67:4 and 6), though common in Egypt, is unusual in Palestine.

## TOMB 11 IN SQUARES V 19-20

Tomb, date uncertain; contents, MB I and EI I

Contents illustrated on Pl. 164

A circular cave in the rock. The roof had been broken through by quarrying. Not all of the plan was recovered because work was stopped as it progressed eastward owing to increased danger to the workmen. At the north side of the cave were found a few human bones. MB I and EI I pottery was scattered throughout the cave.

## TOMB 14 IN SQUARE V 19

Tomb, date uncertain; contents, chiefly EI I

Contents illustrated on Pl. 164

A small circular rock-cut chamber with entrance through a hole at the west opposite T. 36 B (see Fig. 128). It is possible that it was part of T. 36. The floor was more than two meters below the entrance. The small amount of pottery found (not illustrated) was principally EI I, with some EB (Stages I-IV) and LB II sherds. The skeletal matter was much decayed and broken.

## TOMB 17 IN SQUARE W 18

EI I

Contents illustrated on Pl. 68

A rock-cut grave with overhanging ledge discovered during the removal of T. 19 and the débris surrounding it (see Pl. 1 and p. 129). T. 17 contained the skeleton of a middle-aged woman (Fig. 141) lying at full length on back, partially under the rock ledge, with head to west-southwest (Fig. 142). Two pilgrim flasks (see Pl. 68:2) had been placed near her neck, and at her feet was a large pottery bowl (Pl. 68:3) with a small pottery<sup>31</sup> bowl (Pl. 68:1) inside it. Though the contents were *in situ*, the grave had been rifled, and aside from the pottery there remained only a carnelian bead and a flint scraper (not illustrated).



FIG. 141.—TOMB 17, ROCK-CUT GRAVE

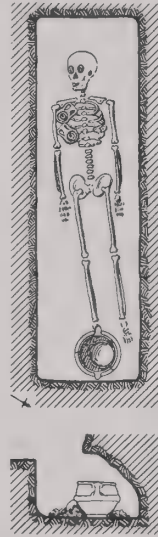

FIG. 142.—PLAN AND SECTION OF TOMB 17. SCALE, 1:40

## TOMB 29 IN SQUARE V 18

Tomb, MB I(?); contents, EI I

Contents illustrated on Pl. 68

An irregular cave entered through a vertical opening which had been closed at the bottom with a large stone. This type of entrance suggests MB I as the period of cutting, though inside irregularity was unusual in shaft tombs. The pottery, which includes several interesting painted pieces, had been disturbed.

## TOMB 30 IN SQUARE V 18

EI I

A disturbed tomb of little interest containing four pottery bowls of well known EI I types (not illustrated).<sup>32</sup>

## TOMB 39 IN SQUARE V 18

Tomb, MB I; contents, EI I with intrusions

Contents illustrated on Pls. 68-69 and 164-68

A shaft tomb with two irregular chambers (Fig. 143). General collapse of rock cut the shaft in two, so that it was possible to see the entire section of it and the entrance (see Fig. 126). The type of shaft would indicate that the cutting was made in MB I. The tomb contained a

<sup>31</sup> Called bronze in *OIC* No. 4, p. 57.<sup>32</sup> Nos. x 1-3 (cf. Pl. 70:9) and x 5 (cf. Pl. 71:8).

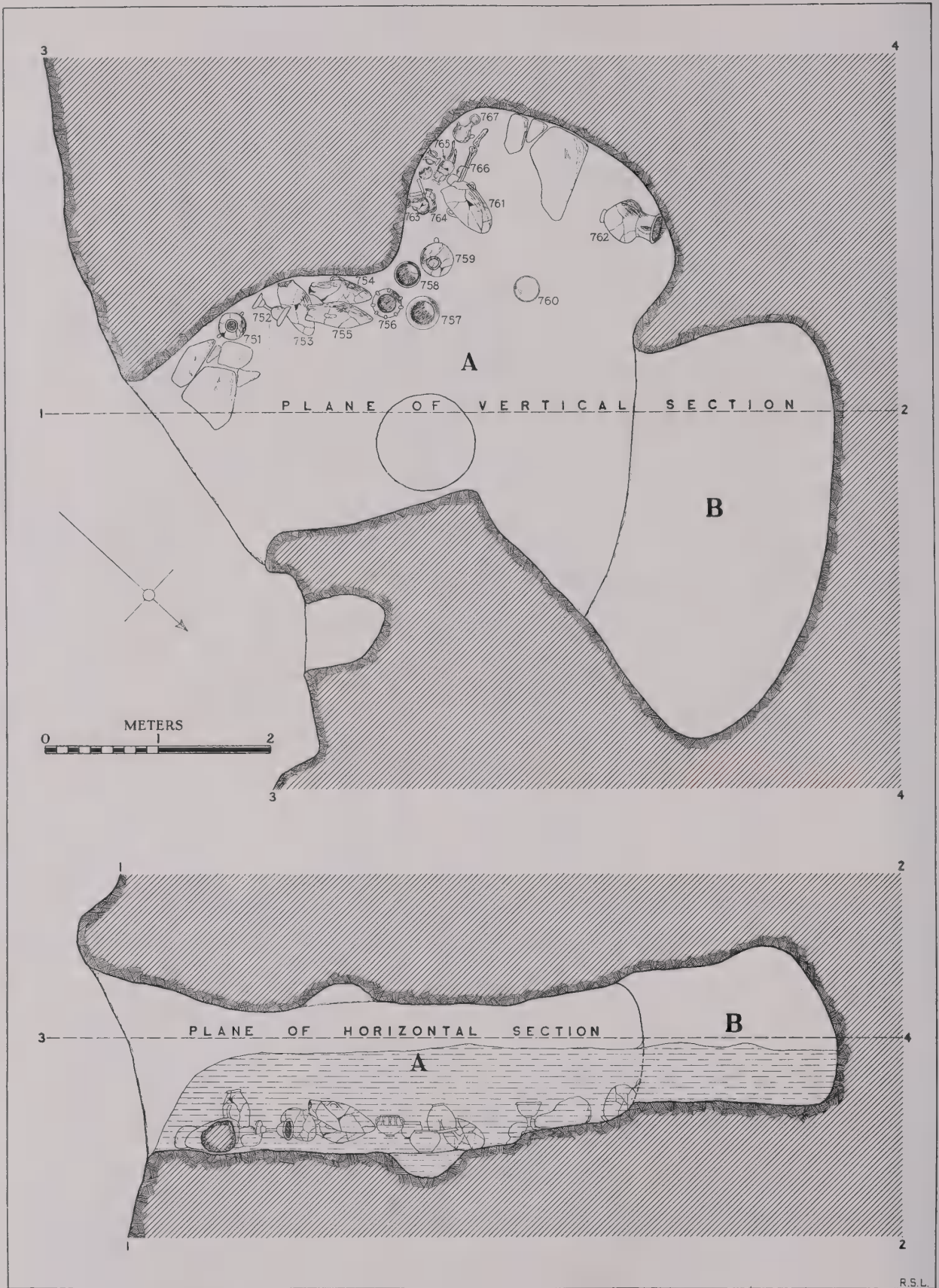

FIG. 143.—PLAN AND SECTION OF TOMB 39. SCALE, 1:50

few bones and a remarkably fine group of EI I pottery (Fig. 144) which may be compared with that of the EI I burials in T. 1101-2 Upper (see p. 26 and Pls. 8-9 and 87). Most of the contents showed disturbance. Two Hyksos objects (Pls. 165:2 and 167:7) were apparently intrusive. An object of considerable historical importance is a gold medallion (Pl. 166:8) bearing the so-called "royal" or "Cappadocian" sign (see p. 163).



FIG. 144.—TOMB 39 A

TOMB 61 IN SQUARE Q 15

EI I?

A burial in débris just above the rock surface at the foot of the mound. It probably belongs to the same period as T. 62 and other EI I tombs near by (see Pl. 1). An adult skeleton lay at full length on its back with head to southwest. The skull was much damaged (Fig. 145). There was no furniture whatever.

TOMB 62 IN SQUARE Q 15

EI I

Contents illustrated on Pls. 69-70 and 168

A rock-cut grave with overhanging ledge, at the foot of the mound. An adult skeleton lay at full length on back (Fig. 146) with head to southwest. The skull and upper part were missing. Since gold was found in the grave, it is likely that the disturbance was caused by beasts—not by men. All the small objects lay in the southwest half of the grave, except a "bronze" bowl (Pl. 168:17) which was inside a pottery bowl (Pl. 69:9). A large jar (Pl. 70:1) was in the disturbed filling.



FIG. 145.—TOMB 61 FROM NORTHWEST

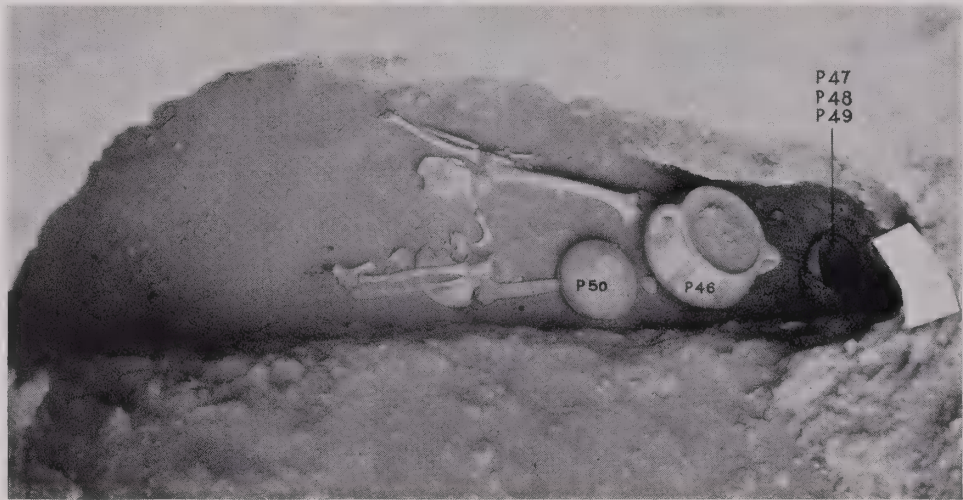

FIG. 146.—TOMB 62 FROM SOUTHEAST



FIG. 147.—TOMB 71 FROM NORTHWEST

## TOMB 71 IN SQUARE Q 15

EI I

Contents illustrated on Pls. 70 and 169

A pit in the rock containing an adult lying at full length on back with head to southwest (Fig. 147).



FIG. 148.—TOMB 72 FROM EAST

## TOMB 72 IN SQUARE Q 15

EI I

Contents illustrated on Pl. 70

A burial in débris near the foot of the mound (Fig. 148). The bones, those of an adult, were too fragmentary for the original position of the body to be determined.

## TOMB 221 IN SQUARES T 16-17

Tomb, EI I; contents, chiefly EI I

Contents illustrated on Pls. 70-72 and 169-70

A rock-cut tomb with four chambers, entered by means of a shaft and stairs (Fig. 149), under the MI wall 220 (see Pl. 1). The roof had been almost completely destroyed, making

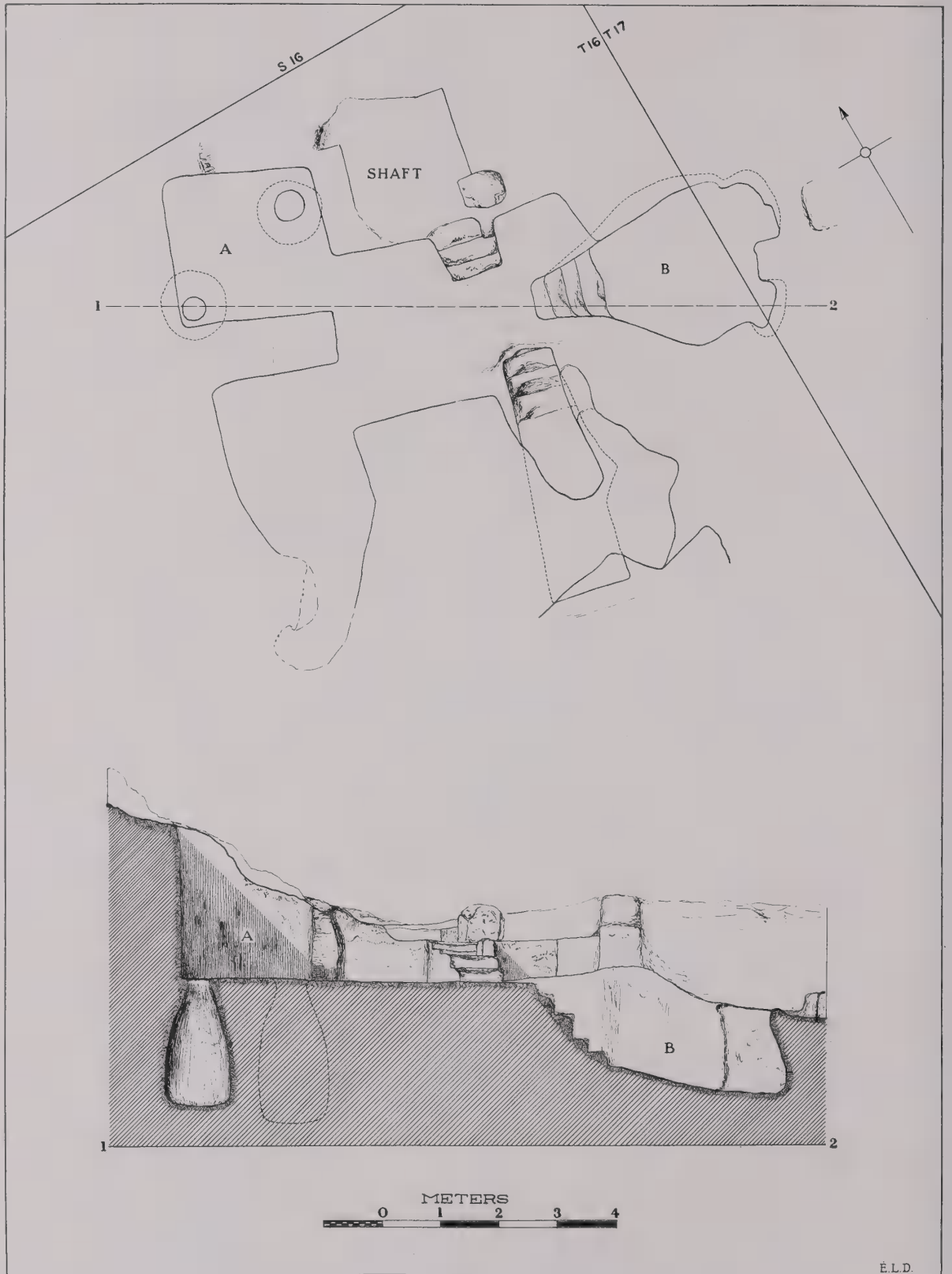

FIG. 149—PLAN AND SECTION OF TOMB 221. SCALE, 1:100



FIG. 150.—TOMB 221 FROM SOUTHEAST

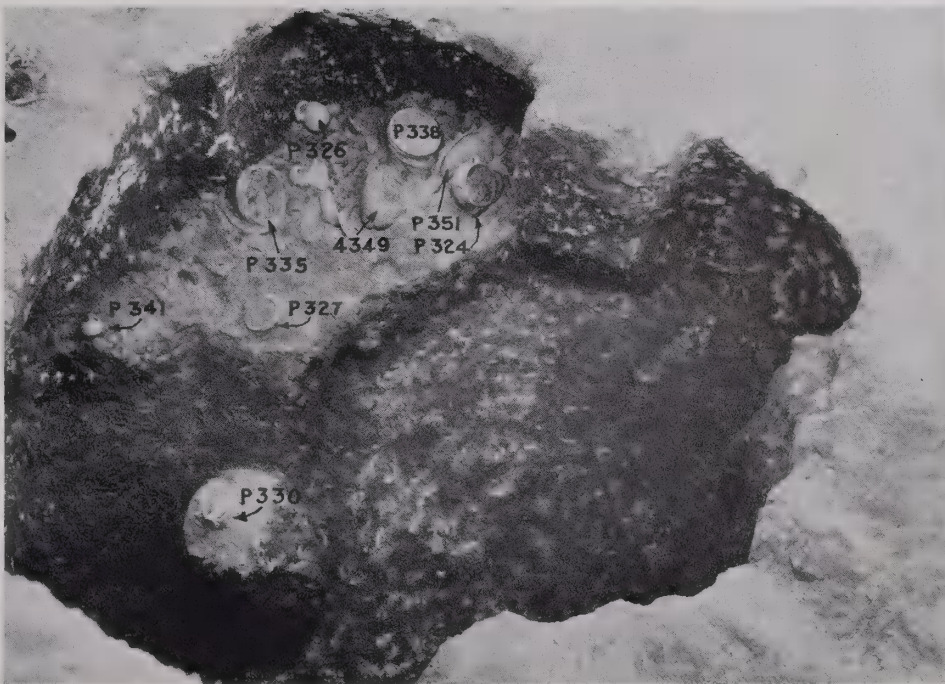

FIG. 151.—TOMB 221 B FROM WEST



FIG. 152.—TOMB 237 FROM SOUTH

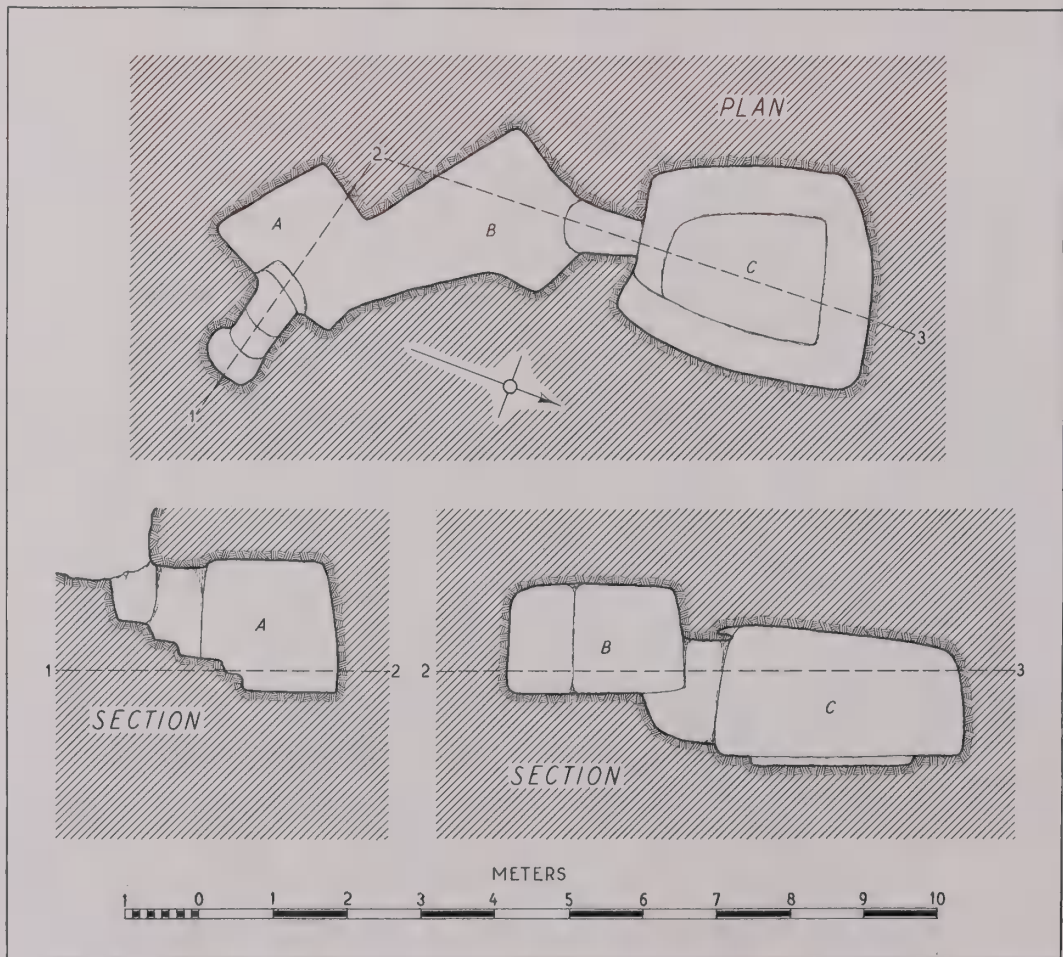

FIG. 153.—PLAN AND SECTIONS OF TOMB 1090. SCALE, 1:100

intrusion possible (Fig. 150). The tomb had been rifled in antiquity and may have been adapted for storage, for cut in the floor of A were two small silos which do not look funerary.

In B a quantity of funerary pottery lay with a few fragments of bone under intrusive débris. This pottery was confined almost entirely to the northeast corner of the chamber (Fig. 151), and it looked as though the rest of the floor had been cleared in antiquity. Most of the vessels were badly crushed, and only two small flasks (P 330 and P 343; see opp. Pl. 72) were unbroken. Though the group is incomplete, it is homogeneous and falls into EI I. The rest of the tomb produced only mixed sherds (not illustrated), except for one lamp (Pl. 70:6) found in A.



FIG. 154.—TOMB 1090 A, LOOKING SOUTHEAST

## TOMB 237 IN SQUARE Q 15

E I I

Contents illustrated on Pls. 72 and 170

A burial in débris near the base of the mound 2.5 below the surface. There was one fairly complete adult skeleton at full length (Fig. 152) more or less on back, with head to north-northeast and arms at sides.

## TOMB 1090 IN SQUARES T-U 16

E I I

Contents illustrated on Pls. 73 and 170

A rock-cut tomb with entrance at the east (Fig. 153). The entrance steps and A were under the MI wall 220 (see Pl. 1). The roof had been quarried away over B and most of A but re-

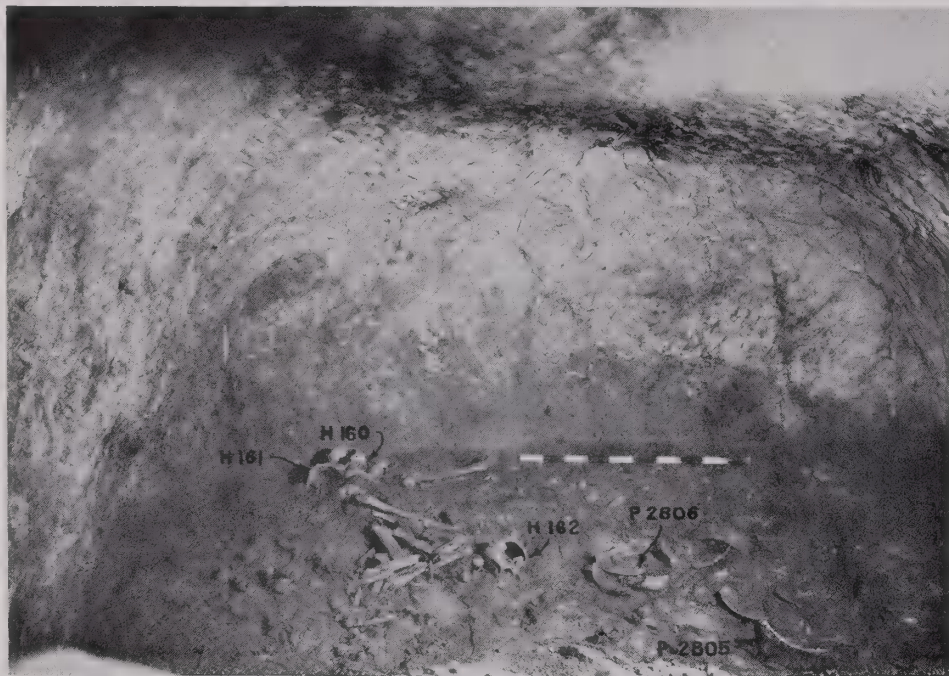

FIG. 155.—TOMB 1090 C, LOOKING NORTH FROM ENTRANCE

mained intact over C. A and B were full of mixed débris which had been laid down as the foundation for wall 220, and some débris had made its way through the entrance to C, forming a cone inside.

Confusion was evident throughout. All that was left of the contents of A is shown in Figure 154. Only one bowl (Pl. 73:11) was found in B. A layer of waterlaid mud a few centimeters thick covered the floor of C. Through it could be seen the outline of a shelf 12 cm. high (see Fig. 157). In and protruding through the mud were three pottery vessels (Pl. 73:12-14) and the remains of eight adult skeletons (e.g. H 160-63). There was no sort of order. Most of the bones lay huddled together in the northwest corner (Fig. 155), and three skulls were nearer the entrance.

T. 1090 has a certain similarity to T. 221 (see Fig. 149).

## TOMB 27 IN SQUARE V 18

Tomb, date uncertain; contents, EI II  
 Contents illustrated on Pls. 74 and 171

One or more small irregular caves with collapsed roof. The contents were disturbed but form a homogeneous EI II group.

## TOMB 64 IN SQUARES S-T 18

Tomb, date uncertain; contents, EI II  
 Contents illustrated on Pls. 74 and 171

T. 64 looks like the approach to a tomb. It was cut out of the rock. The stones in the northwest wall blocked a hole which had been made into T. 63 (see p. 110 and Figs. 131-32). There were no signs of burial in T. 64. The stone wall (see Fig. 132) would suggest that it was used as a room, probably during EI II, which is the date of the pottery found grouped together on the floor. The other objects have no distinguishing features, except for a figurine (Pl. 171:4) which by its ware seems to belong with the pottery.

## TOMB 5 IN SQUARES R 17-18

Tomb, date uncertain; contents, MI, Roman, and Arab  
 Contents illustrated on Pl. 171

A rock-cut chamber with two irregular entrances, the original entrance lying at the east (Fig. 156). A circular pit in the floor was probably a cistern.

Whether or not burials are represented by the deposits is questionable. There was a mass of MI sherds, of which only a lamp is worth illustrating (Pl. 171:7). A Roman occupancy is represented by a pottery jug, a fragment of a glass bracelet(?), and a coin of Elagabalus. From a still later period comes a coin of Aḥmad ibn Ṭūlūn (A.D. 868-83) struck at Damascus toward the end of his reign (Pl. 171:10).

## TOMB 47 IN SQUARE R 18

Tomb, date uncertain; contents, LB II and MI  
 Contents illustrated on Pls. 74 and 171-72

Though most of the pottery from T. 47 is MI, there were remnants of a LB II deposit. A Greek lamp (No. 1762) also was found, but since it lacked all association with other pottery or bones, it is doubtful whether it represents a burial.

## TOMB 76 IN SQUARES S-T 16

Tomb, MB I(?); contents, chiefly Iron Age  
 Contents illustrated on Pls. 74 and 172-73

A rock-cut tomb with three chambers (see Pl. 1). The roof had been quarried away, and débris of all sorts had accumulated. There were a few fragmentary skeletal remains in A. The general shape of the tomb suggests that of the shaft tombs and perhaps places it in MB I. Holes in the floor at the northwest and southeast corners of A indicate that it was used for storage at some time.

## TOMB 80 IN SQUARES T 16-17

Tomb, date uncertain; contents, chiefly LB and Iron Age  
 Contents illustrated on Pls. 75 and 173-75

A rock-cut tomb (see Pl. 1), so badly damaged by quarrying that no plan could be made. The entrance is an arched doorway 1.3 high and 1.0 wide. Some of the roof remained in position near the entrance, but most of it had disappeared. It is called a tomb because of the char-

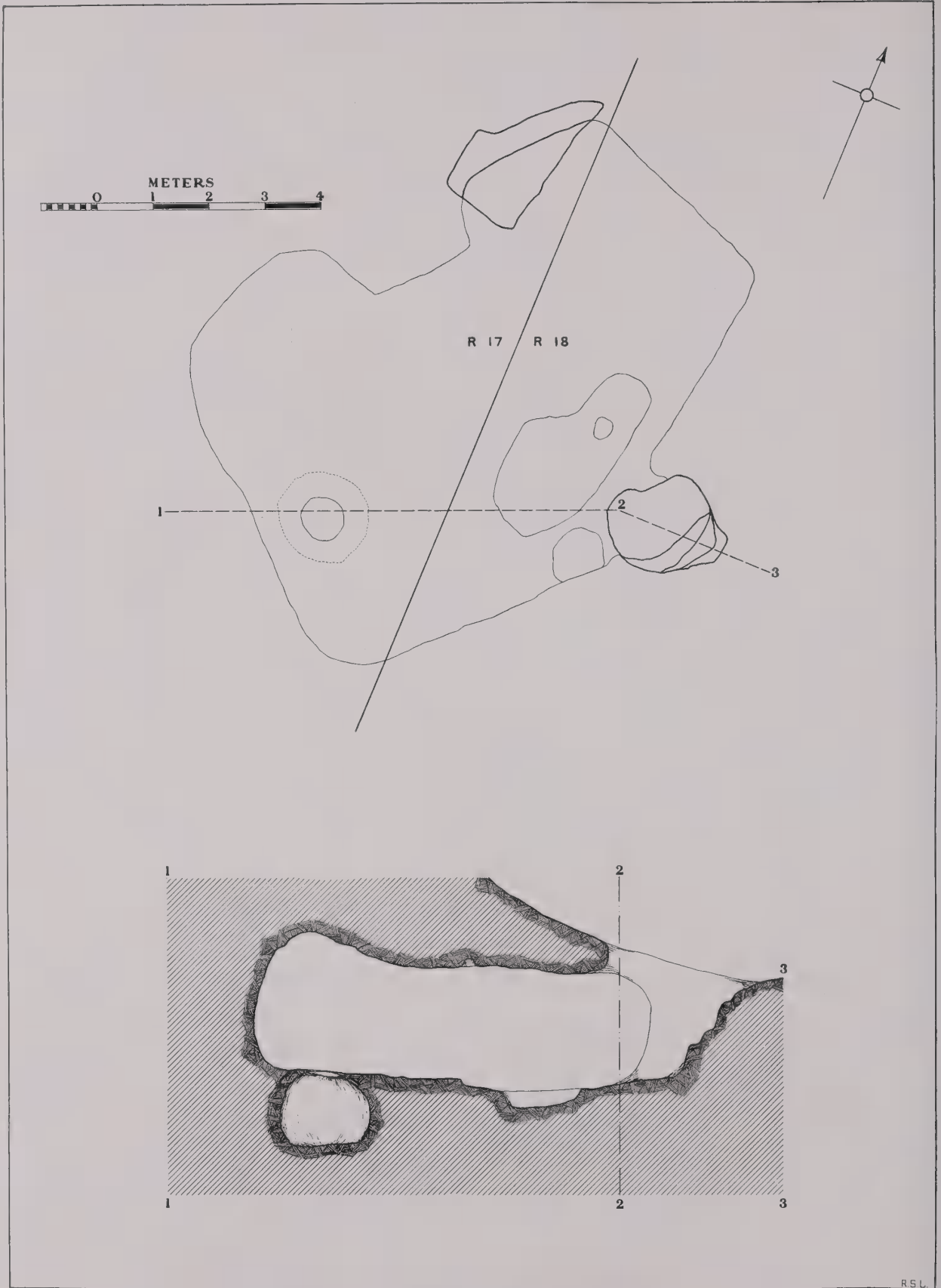

FIG. 156.—PLAN AND SECTION OF TOMB 5. SCALE, 1:100

acter of the entrance, but no bones were found and it cannot be said with certainty that the contents as found were funerary, although two vessels (Pl. 75:4-5) are types common in LB II tombs. With them were found two EI II bowls (Pl. 75:6-7).

In B was found the base of an interesting Egyptian statuette in fayence (Pl. 174:12). A similar specimen from Gerar belongs to the reign of Sheshonk I.<sup>33</sup>

T. 80 C (not visible in Pl. 1 because it is under the roof) produced what appears to be a homogeneous group of E-MI pottery including several bowls decorated with concentric circles (e.g. Pl. 75:8-9), the finest and best made pottery vessels so far found at Megiddo. Similar specimens were found in EI II and MI contexts on the mound and at Samaria throughout the Omri and Ahab period.<sup>34</sup>

The rest of T. 80 produced only a mixture of sherds, a few of which are illustrated to show their diversity (Pls. 75:1-3 and 173:14-17).

The tomb was probably cut not later than LB, and the two LB II pots (Pl. 75:4-5) may belong to the original burial. The quarrying which destroyed the tomb probably took place early in MI.

#### TOMB 19 IN SQUARE W 18

Roman, about A.D. 400<sup>35</sup>

Contents illustrated on Pl. 175

A rectangular grave lined and covered with limestone slabs (Fig. 157) probably taken from an earlier floor. One end was rock cut (Fig. 158), and the other rested on débris which covered T. 17 (see Pl. 1 and p. 117).



FIG. 157.—TOMB 19 BEFORE REMOVAL OF COVER SLABS, FROM NORTHEAST

Two periods of use were indicated. The later burial consisted of a single adult skeleton (Fig. 159), which lay at full length on its back with head to northwest. Although the arms were displaced, they probably had lain at the side of the body. The head and lower jaw were likewise out of position. The grave had been disturbed in antiquity when the south cover slab was removed, and no artifacts were clearly associated with the skeleton.

The earlier burial included three skeletons lying side by side—two adults with a child between them (Fig. 160). They also lay on their backs but were considerably cramped by the

<sup>33</sup> Petrie, *Gerar*, Pl. XLV 26 and p. 20.

<sup>34</sup> *OIP* XLII, "Pottery Types," § 58.

<sup>35</sup> See *OIC* No. 4, p. 56.

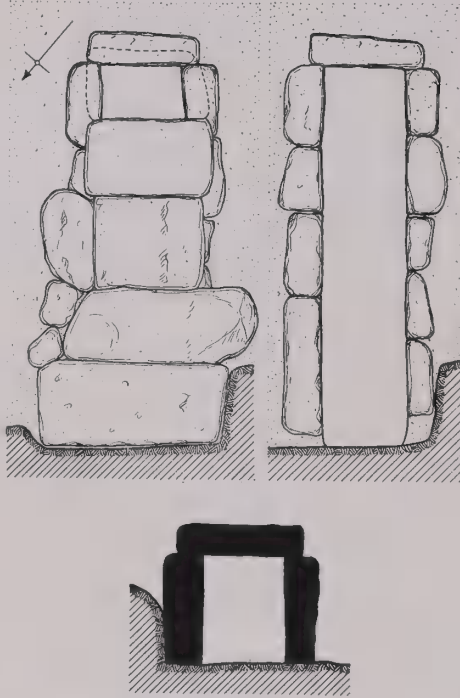

FIG. 158.—PLANS AND SECTION OF TOMB 19. SCALE, 1:40



FIG. 159.—TOMB 19 FROM NORTHWEST, SHOWING LATER BURIAL WITH THREE EARLIER SKELETONS AND ROMAN GLASSWARE UNDERNEATH



FIG. 160.—TOMB 19 AFTER REMOVAL OF LATER BURIAL, FROM NORTHWEST

narrowness of the grave, which was less than half a meter wide. Their heads were under the feet of the later skeleton (see Fig. 159). A basalt bowl and some glassware (see p. 189) were found at their feet (see Fig. 160).

Recently a Roman tomb containing small glass bottles like Nos. x 432 and x 434 (Pl. 175: 11 and 13) was discovered near the "Tombs of the Kings" in Jerusalem.<sup>36</sup> Although the tomb was more complex than that at Megiddo, it is of interest to note that as in T. 19 cover slabs were used and two skulls were found at opposite ends of the grave.<sup>37</sup>

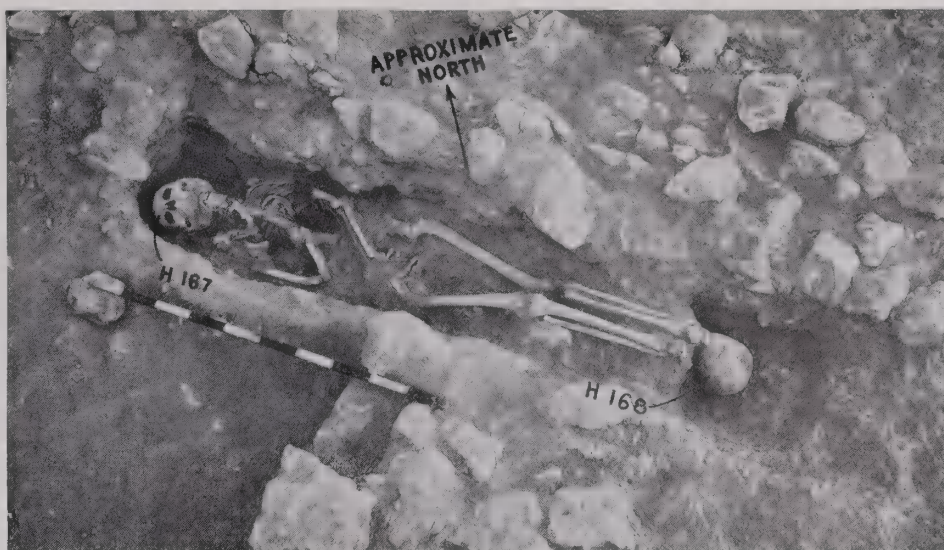

FIG. 161.—TOMB 232 WITH UPPERMOST SKELETON AND SKULL OF MIDDLE SKELETON EXPOSED

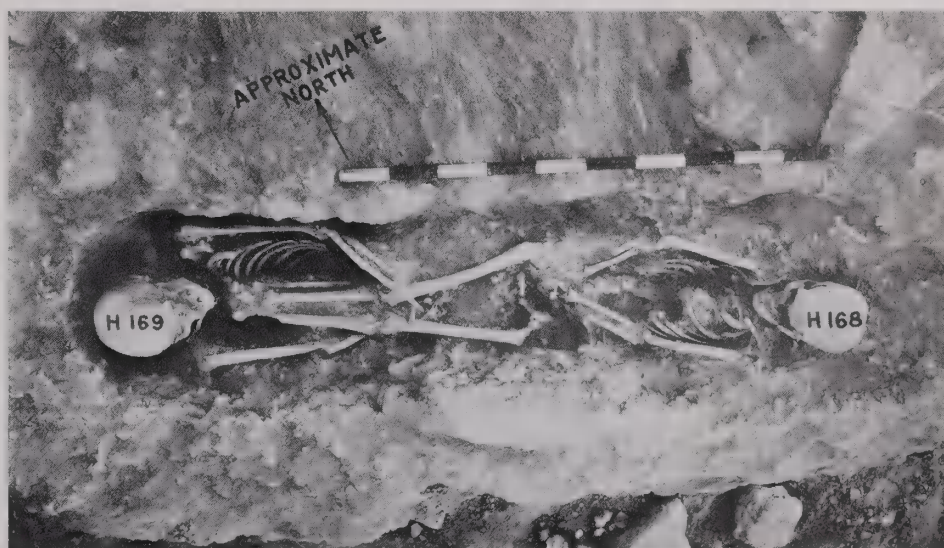

FIG. 162.—TOMB 232 WITH MIDDLE SKELETON AND PART OF LOWEST SKELETON EXPOSED

<sup>36</sup> See R. W. Hamilton and S. A. S. Husseini in *QDAP* IV, Pl. LXXXI 12.

<sup>37</sup> *Ibid.* Fig. 1 C and p. 172, tomb 10 a.

## TOMB 907 IN SQUARE V 18

Roman?

A rock-cut grave ( $2.0 \times .60 \times .80$  deep at east end) with the long axis roughly east and west. The rock had perished considerably, destroying the outline particularly at the west end. In the south side was a recess ( $.5 \times .3 \times .3$  deep) containing fragments of skull and other bones. There were three adult skulls together at the west end, and although there were almost no other bones, it may be presumed from the shape of the grave that the burials were full length. The only article found close to them was a small fragment of plain Roman glass (M 2533; not illustrated).

## TOMB 66 IN SQUARE T 18

Date uncertain

A rock tomb (see Fig. 29) discovered by Schumacher.<sup>38</sup> He seems to have found nothing in it. The edge had been damaged by quarrying. So far no parallel has been found at Megiddo, and there is doubt as to the period to which it belongs.

## TOMB 232 IN SQUARE S 15

Date uncertain

Contents illustrated on Pl. 175

A grave (1.85 long) with rubble sides and ends. Four stone slabs (20 cm. thick and averaging 6 cm. wide) covered 1.5 of its length. Upon removal of the slabs and some 20 cm. of earth, skeleton H 167 (Fig. 200) became visible. It lay on its back with head to west-northwest, right arm flexed toward left breast (hand missing), left arm down with hand over sacrum. The legs were slightly raised because underneath was H 168 (Fig. 161), also on its back, but with head to east-southeast and both hands over sacrum. Under H 168 was H 169 (Fig. 162; see also Figs. 201-2), on its back with head to west-northwest and both hands over sacrum.

A few potsherds (not illustrated), evidently intrusive, a flint implement and a "bronze" needle were the only objects found in the grave. The flint lay 30 cm. east-southeast of the mouth of H 167, and the needle just east-southeast of the skull of H 168 with a little wood ash beside it. The position of the grave, quite high in the débris at the foot of the mound, makes it probable that it belongs fairly late in the Iron Age or even in the classical period.



FIG. 163.—TOMB 236

<sup>38</sup> Felsgrab G in G. Schumacher, *Tell el-Mutesellim I* (Leipzig, 1908) 172. See also I. Benzinger in *Deutscher Palaestina-Verein, Mitteilungen und Nachrichten*, 1904, p. 72 and Fig. 25.

TOMB 236 IN SQUARE T 16

Date uncertain but earlier than MI

A rock-cut grave (.45 wide and .35 deep) under the MI wall 220 (see Pl. 1). One end had been destroyed, so the length could not be determined (Fig. 163). Two cover slabs (.90 × .60 × .23 and .80 × .45 × .20) were found over it, and there had no doubt been others. The body of an adult lay at full length on back with head to south-southwest. There was no furniture whatever, but the burial must have been earlier than wall 220.<sup>39</sup>

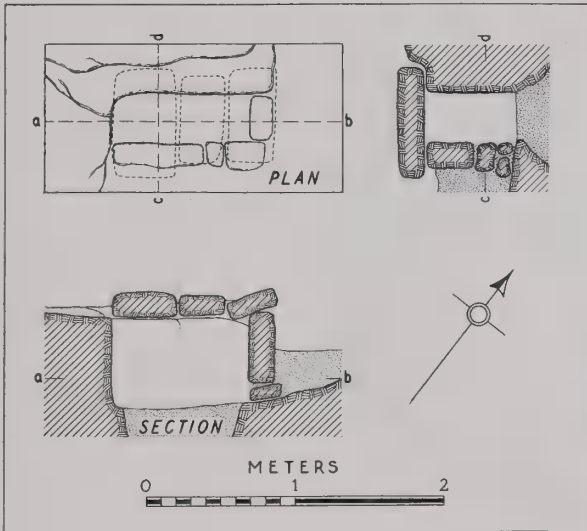

FIG. 164.—PLAN AND SECTIONS OF TOMB 854. SCALE, 1:50



FIG. 165.—TOMB 854

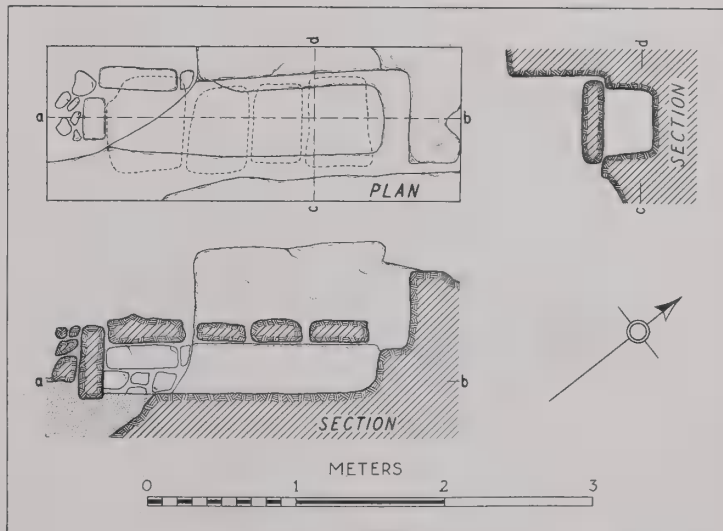

FIG. 166.—PLAN AND SECTIONS OF TOMB 857. SCALE, 1:50

<sup>39</sup> Similar graves found on the tell are dated to about 600 B.C. (*OIP* XLII, T. 1263, 1265, and 1276-77).

## TOMB 854 IN SQUARES U 15-16

Date uncertain

A grave partly rock cut and partly built of stone slabs (Fig. 164) and covered by three stone slabs (Fig. 165). Nothing was found in the filling except a few mixed sherds (not illustrated) and one finger bone. Though the tops of the cover slabs were about 60 cm. lower than the base of the MI wall 220, the grave is not necessarily earlier than the wall because it did not run under it (see Pl. 1). Compare T. 236 and T. 19 for possible date.<sup>39</sup>

## TOMB 857 IN SQUARE U 16

Date uncertain

A grave partly rock cut and partly built of stone slabs and covered by four stone slabs (Fig. 166), with its long axis northeast and southwest. It had evidently been disturbed in antiquity, but enough of the skeleton remained to show that the body had been deposited at full length on back with head to southwest. Compare T. 236 and T. 19 for possible date.<sup>39</sup>



FIG. 167.—TOMB 950 FROM SOUTHEAST

## TOMB 950 IN SQUARE M 11 (SEE FIG. 2)

Date uncertain

Contents illustrated on Pl. 175

An adult female burial in earth, full-length with head, slightly raised, to northwest (Fig. 167). It lay between stable unit 361 and Schumacher's main trench,<sup>40</sup> the edge of which had missed the skull by 20 cm. The only things found with the skeleton (H 145) were a bead and some seeds which looked like olive stones. There is nothing to indicate the precise age of the burial, but by its situation it can hardly be earlier than EI and might be very much later.

<sup>40</sup> See *OIC* No. 9, Fig. 17.

### III

#### BURIAL CUSTOMS

In considering this summary it is to be borne in mind that there has been excavated only a small proportion of the burials which must have been made at Megiddo during each period. It would thus be rash to draw very general conclusions from the evidence so far obtained. For instance, it is quite possible that during MB I shaft tombs were the burial places only of the richer class and that the common people were buried in simpler tombs. I do, however, believe that our tombs show pretty clearly the transition in burial position from the fully contracted to the full-length, the latter coming in for the first time during LB I.

A chronological index of tombs and burials is appended to this chapter, to be used for reference in connection with the following chronological summary.

##### CHALCOLITHIC AND EARLY BRONZE (STAGES I-VII)

Two burials in *débris* (T. 1126-27) were intrusive through a habitation floor. Burials in caves were fairly common. In one a child skeleton, which probably belonged toward the end of the Chalcolithic period, lay over a pot-hole (T. 1101 A). In another cave the burial was on a rock shelf (T. 1122). Four rock-cut chamber tombs were found (Nos. 14, 910, 1128, and 1141+1145), one with steps leading down into it. T. 903 Upper and T. 1103 appeared to be ossuaries where remains were collected, presumably some time after burial, perhaps to clear other tombs for reuse.

The position of burial where ascertainable (i.e., of four undisturbed skeletons) was fully contracted on the right side. No special orientation was apparent.

##### EARLY BRONZE (STAGE 0-I)

The only Stage 0-I burials were found in T. 1101 B and T. 1102, two connected rock-cut chambers, and consisted of the bones of fourteen individuals in no order, perhaps an ossuary (cf. T. 903 Upper and T. 1103). A considerable amount of charcoal was mixed with the bones, and a number of them bore signs of burning.

##### MIDDLE BRONZE I

Caves continued to be used, but the shaft tomb was the predominant type (see Table I). The only skeleton whose position could be definitely determined was contracted on its left side with head to east (T. 891 B).

The normal arrangement of a shaft tomb is shown in Figure 168. Such tombs were not oriented toward any particular point of the compass, but the shaft seemed always to be downhill from chamber A. The shaft was usually about a meter square and a couple of meters deep, with footholds either recessed in or, more rarely, projecting from the sides. Sometimes both types occurred in the same shaft (see T. 877). Access from the shaft to the central chamber (A) was obtained by a doorway seldom as much as 80 cm. high and averaging 60 cm. wide at the base but rather less at the top. To get a corpse through such an opening cannot always have been easy. It was customary to block this doorway with a stone (see Fig. 44) and to fill the shaft with *débris*. Careful examination of the rims of shafts revealed in one or two cases a small ridge which was all that remained of a coating of lime plaster (see T. 878). Such plaster, being very like the rock itself, from which it was made, concealed the shaft.

Chamber A was usually some two meters broad, and from two and a quarter to nearly three meters long. Its height varied between a little over a meter and as much as two meters, and the roof generally sloped upward away from the shaft. The floor was sometimes flat, but it was more common to find that rather less than half of it, just inside the entrance, was 20–40 cm. lower than the rest and thus formed a shallow pit.

Three chambers (B, C, D) opened off the central chamber (A). Their entrances were above the floor of chamber A. The sills were level with the floors of the chambers to which they led, and these floors were flat. The entrance to chamber B was usually near the middle of the wall opposite the shaft, but those to chambers C and D, though sometimes centered, were frequent-

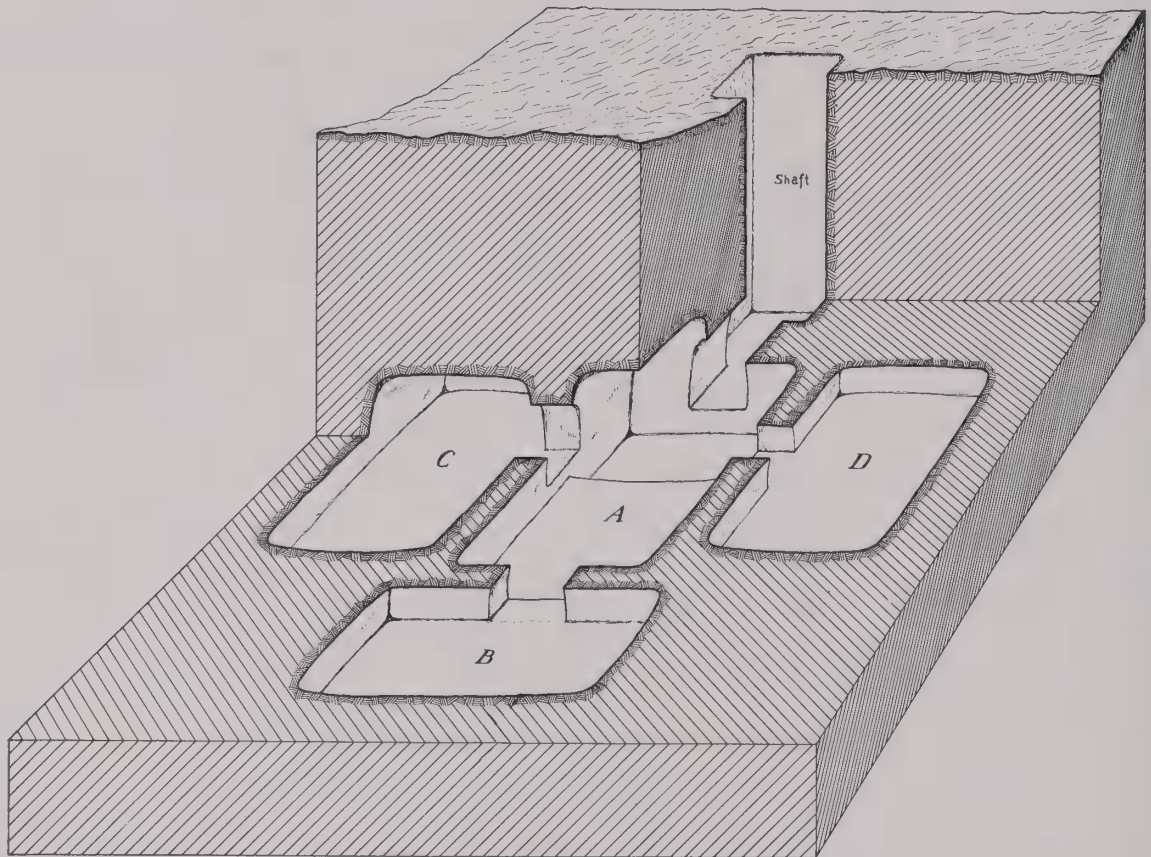

FIG. 168.—PERSPECTIVE DRAWING OF A NORMAL SHAFT TOMB

ly offset. These doorways were usually about the same size as the entrance from the shaft, though some were slightly larger, and most of them narrowed toward the top in a similar manner. Where they were much larger, as in T. 1100 (see Fig. 104), it is likely that they had been made so when the tombs were reused. In no case was there any indication that these inner doorways had ever been blocked. In T. 84, however, where subsidiary chambers opened off the shaft itself (see Fig. 136), their entrances had been blocked with stones.

The walls of the chambers sloped inward toward the top and were only roughly at right angles to one another. Corners were in most cases rounded, and altogether the tombs gave the impression that they had been cut by eye alone and to no special measurements. The rock surfaces were as a rule only fairly well finished, being less smooth than those in the earlier T. 910 (see p. 17). In a few cases they had been whitewashed; more rarely, plastered. Numer-

ous metal tool marks could be seen. The cutting edges of the tools varied in width between 5 cm. and 12 mm., some being square and others rounded. It seems likely that the narrower marks were made by picks, and the broader marks by either picks or chisels. Square marks were presumably made by new or newly sharpened tools, and rounded marks by tools more or less worn.

It was not uncommon to find in the walls and floors small holes 4–10 cm. in diameter and 15–30 cm. deep (see Tombs 877, 884, 911, 989, 1014, 1098, 1100). Some contained objects, usually weapons, many of which had been intentionally mutilated or “killed.” With the exception of a copper borer from T. 1014 B (Pl. 102:8) none of the objects found in holes belonged to the original (MB I) burial in the tomb concerned.

With the exception of a few obviously intrusive sherds no pottery earlier than MB I was found in any of the shaft tombs, and it may reasonably be presumed that it was during that period that they were cut. Though a few shaft tombs with very abnormal plan produced only later pottery, it has been assumed that they too were cut during MB I. Such tombs are Nos. 18, 24, 29, 39, and 42. Also attributed to MB I are Nos. 79 (which produced nothing and may have been unfinished), 84 (which contained no pottery and had an abnormal plan), 913 and 1119 (which were unfinished shafts and contained nothing). T. 1100 probably was of MB I origin and had been completely cleared to receive the very large LB I groups found in it. The general shape of T. 76 suggests MB I as the period of cutting.

The fact that many of the shaft tombs were reused in later periods (e.g. Tombs 877, 911–12, 989) would seem to indicate that the rock surface in their neighborhood was clear of earth during the periods of reuse. Otherwise the shafts would never have been found. It was apparently not the general custom to clear a shaft tomb thoroughly before a later burial was put in. It would, however, seem that earlier remains were sometimes swept into the central chamber (A), for it was more usual to find them there than elsewhere.

Every shaft tomb found had been looted in antiquity, entrance having been gained either through the shaft or through holes cut in the walls. Apparently only the most precious articles had been removed in most cases, for pottery and “bronzes” were often found by us *in situ*, even though they must have been plainly visible to our predecessors. If we judge by the disturbed state of most of the skeletons, it would seem that it was customary to bury gold on or close to the persons of the dead and that robbers had dug among the bones in their search for it.

#### MIDDLE BRONZE II

Burials in débris and in pits in the rock, sometimes surrounded by stones, were common (see Table I). A cenotaph (see p. 56) associated with a group of pit graves is worthy of remark. Two masonry tombs (51 and 56) appear to be distinctive for the period. Several MB I shaft tombs were reused (e.g. T. 911–12). Three, possibly four, burials of infants in pots or jars were found (Tombs 247, 253, 257[?], 645). The burial position where ascertainable was contracted, but in most cases less so than in earlier times. Skeletons lay on either side with the head in seven out of eight cases west to northwest.

#### LATE BRONZE I

The reuse of MB I shaft tombs was common, as were burials in débris. There was one pit grave with a rough stone wall on one side (T. 1178). Two pits in a cave floor contained infant jar burials (T. 37 K 4 and M). A third infant jar burial was found in débris (T. 855). Caves were numerous. One (T. 3) had niches in the walls for separate burials. Two chambers (T. 77–78), each with a recess of a size and shape to receive a full-length burial, were cut during this period. An early rock-cut chamber tomb (T. 1141+1145) was reused. Two “killed” (see

p. 137) daggers with their pommels (Pl. 149:2-3 and 6-7) were found thrust into a hole in a reused shaft tomb (1100 D). The partly contracted position remained popular, but full-length burials seem to have come in for the first time, five definite cases being observed. There was apparently no rule of orientation. An unusually placed skeleton was that of a young woman lying full length, face down, arms bent under chest (T. 20).

#### LATE BRONZE II

Rock-cut chambers and MB I shaft tombs were reused, but burials in caves were most common. There were two pit graves (50 and 1250), one reused and surrounded by a masonry wall. One case of "killing" (see p. 137) occurred, an arrowhead (Pl. 153:9) from T. 4. The contracted position would seem to have been entirely replaced by that at full length on the back (see T. 911 B-C). No special orientation was apparent. It is possible that some attempt at mummification had been made in connection with two skeletons in T. 911 B (see p. 67).

#### IRON AGE

The Iron Age is very poorly represented. Several burials can be attributed to EI I. Two graves were cut in such a way as to leave an overhanging ledge (T. 17 and T. 62), and three similar graves were probably contemporary (T. 37 C 1, D, and O). Rock-cut chambers and shaft tombs were reused (see Table I), and two tombs with steps and several chambers were cut (T. 221 and T. 1090). Recesses with shape suggestive of full-length burial were cut in an earlier chamber (T. 1101 C-D). Caves were used, one with a jar burial in a hole in the floor (T. 37 C 2). Another burial in the floor of the same cave (T. 37 B) may have been contemporary; in any case it belongs in EI. There was one simple pit grave in EI I (T. 71). Two apparently "killed" (see p. 137) objects (Pls. 87:5 and 166:8) occurred in that period. Wherever determinable the burial position was full length on the back, with no special orientation.

The only burial definitely attributable to EI II was in a cave (T. 27). One shaft tomb (217) was reused during MI, as were a rock-cut tomb (80, possibly in EI II) and a cave (T. 31).

#### ROMAN PERIOD

A rock-cut grave lined and covered with limestone slabs is dated to about A.D. 400 (T. 19). T. 907 may belong to about the same period. In T. 19 were four skeletons at full length. Though the remains in T. 907 were fragmentary, the shape of the grave would indicate that the burial position was full length. Three other graves with cover slabs are of uncertain date (Nos. 236, 854, and 857).

TABLE I  
CHRONOLOGICAL INDEX OF TOMBS AND BURIALS

Period	No.	Description	Position of Human Skeletal Remains	Page Reference
Chalcolithic (Stages IV-VII)	903	Pit in lime "floor" (ossuary)	Bones of <i>ca.</i> 60 individuals in no order	9
	910	Rock-cut tomb with 8 chambers	Indeterminable	12, 17 f.
	1103	Ossuary in cleft in rock	Bones of <i>ca.</i> 20 individuals in no order	18
	1122	Cave, burial on rock shelf	Indeterminable: 1 adult	18-20
	1126	Burial in débris, intrusive through floor	1 adult fully contracted on r. side, head S.	12
	1127	Burial in débris, intrusive through floor	1 adolescent fully contracted on r. side, head NE.	12
	Chalcolithic to Early Bronze (Stage IV)	1101 A?	Cave, burial over pot-hole	1 child fully contracted on r. side, head ENE.
1128		Rock-cut chamber	Indeterminable: at least 2 adults and 3 small children	20
Early Bronze (Stages I-IV)	9	Pit		20
	14	Rock-cut chamber	None attributable to period	116
	31?	Cave		106
	52			20
	1106*	Cave	Indeterminable: 8 individuals	22
	1141 } 1145 }	Rock-cut tomb with steps and 2 chambers	1 adult (in 1141) fully contracted on r. side, head W.	94-99
	Early Bronze Stage 0-I)	1101 B } 1102 }	Rock-cut chambers, reused (ossuary?)	Bones of 14 individuals in no order
Middle Bronze I		6	Cave	72
	7	Normal shaft tomb	27	
	11	Cave, reused?	None attributable to period (excavation unfinished)	116
	15?	Cave	None found (excavation unfinished)	29
	16	Cave	(Excavation unfinished)	29
	18?	Abnormal shaft tomb?		72
	24	Abnormal shaft tomb		48-50
	29?	Abnormal shaft tomb?		117
	39	Abnormal shaft tomb	None attributable to period	117-19
	41	Abnormal shaft tomb		29
	42?	Abnormal shaft tomb?		51
	58	Abnormal shaft tomb		29
	67	Shaft tomb	None found	29
	76?	Abnormal shaft tomb?	None attributable to period	127
	79?	Shaft tomb, unfinished(?)	None found	29, 31
	84	Abnormal shaft tomb	None attributable to period	115
	217	Abnormal shaft tomb	None attributable to period	31
	877	Abnormal shaft tomb	Indeterminable	33-36
	878	Normal shaft tomb	Indeterminable: 5 adults and 3 children	40
	880	Abnormal shaft tomb	Indeterminable	40 f.
	884	Normal shaft tomb	Indeterminable	41-43
	891	Normal shaft tomb	Indeterminable in A (probably 2 individuals) and C; 1 adult in B fully contracted on l. side, head E.	43-45
	911	Normal shaft tomb	Indeterminable	64-68
	912	Abnormal shaft tomb	None attributable to period	69-72
	922	Abnormal shaft tomb	Indeterminable: at least 1 adult and 1 child	45
	989	Normal shaft tomb	None attributable to period	40
	1014	Shaft tomb	Indeterminable in A; 1 adult in B, probably contracted	47
	1098	Normal shaft tomb	Indeterminable: 2 adults and 1 adolescent in A	43
	1100	Normal shaft tomb	None found	88 f.
	1120	Abnormal shaft tomb	Indeterminable	47

\* Burials may belong with Chalcolithic pot-holes.

TABLE I—Continued

Period	No.	Description	Position of Human Skeletal Remains	Page Reference
Middle Bronze	24	Abnormal shaft tomb, reused		48-50
II	42	Reused abnormal shaft tomb?		51
	43	Pit		52
	44	Pit		52
	45	Pit		52
	46	Pit		52
	49	Pit		54
	50	Pit surrounded by masonry wall†		54
	51	Rock-cut and masonry passage and chamber	Indeterminable	55
	53	Pit	Indeterminable: 1 individual	55
	56	Masonry tomb		55
	233	Pit	Indeterminable, but probably at least partly contracted from size of pit	55
	234	Pit	Indeterminable, but probably at least partly contracted from size of pit	56
	244?	Grave surrounded by stones	Indeterminable: 1 adult	56
	247	Jar burial	1 infant contracted on r. side, head NW.	57
	251	Grave surrounded by stones and mud	1 adult partly contracted on l. side, head WNW., holding infant in same position; 1 infant contracted, head W., at feet of adult	57-59
	252?	Grave in rock chippings surrounded by stones	1 adult probably contracted; 1 adult partly contracted	59
	253	Jar burial	Indeterminable (but probably contracted; cf. T. 247): 1 infant	59
	254	Burial in débris	1 child partly contracted on r. side, head NW.	59
	255?	Rock-cut grave	Indeterminable	60
	257?	Pot burial	1 infant contracted	60 f.
	258	Burial in débris	1 adult partly contracted on l. side but somewhat twisted onto back, head NW.	61
	644	Burial in débris	Indeterminable: 1 adult	61
	645	Jar burial	Indeterminable: 1 infant	61
	868	Burial in débris	1 child partly contracted apparently on r. side, head NW.	61
	911	Normal shaft tomb, reused	In A: 1 adult partly contracted on r. side, head ESE.; fragments of ca. 8 other individuals; hand bones and teeth in bowls; in D: 1 adult probably contracted	64-68
	912	Abnormal shaft tomb, reused	None attributable to period	69-72
Late Bronze I	3	Cave with burial niches		72
	6	Cave, reused		72
	18	Reused abnormal shaft tomb?		72
	20	Cave	1 young woman full length, face down, arms bent under chest, head SSW.	72, 74
	21	Cave, reused?		74
	26	Cave, reused?	None attributable to period	103
	31	Cave, reused		106
	36	Cave, reused?	None attributable to period	106
	37 K 4	Jar burial in pit in cave floor	Indeterminable: 1 infant	80
	37 M	Jar burial in pit in cave floor	1 infant partly contracted on l. side, head NW.	81
	38	Cave, reused?		82
	40	Cave, reused?		106
	73	Cave, reused?	None attributable to period	111-13
	75	Burials in débris	Indeterminable: 2 adults	82
	77	Rock-cut chamber with recess	Indeterminable, but size of recess would allow for 1 adult full length, though bones were on floor of chamber	82

† Wall may be LB II.

TABLE I—Continued

Period	No.	Description	Position of Human Skeletal Remains	Page Reference	
Late Bronze I— (continued)	78	Rock-cut chamber with burial in recess	1 adult probably full length, head NW.	85	
	217	Abnormal shaft tomb, reused	None attributable to period	31	
	855	Burials in débris	2 adults partly contracted, 1 on l. side, heads E.; 1 infant contracted in jar	87	
	856	Burial in débris	1 adult on l. side (legs missing), head W.	87	
	876	Burial in débris	1 adult apparently partly contracted, head NNW.	87	
	877	Abnormal shaft tomb, reused	None attributable to period	33-36	
	921	Burials in filling of earlier cave	1 child partly contracted on l. side, head W.; fragments of a 2d individual	87	
	1100	Normal shaft tomb, reused	Mostly indeterminable: at least 17 individuals—3 adults full length, heads W., in A; 1 adult (legs missing), head W., in D	88 f.	
	1141 } 1145 }	Rock-cut tomb with 3 chambers, reused	5 adults and 1 infant partly contracted on r. side, 1 adult contracted on l. side, 2 adults full length, all heads N. (all in 1145 B)	94-99	
	1178	Pit with rough stone wall on one side	1 adult and 1 child partly contracted on r. side, heads S.	99 f.	
	Late Bronze II	1	Cave	(Excavation unfinished)	100
		2	Rock-cut chamber, reused dwelling?		101
		3	Cave with burial niches, reused		72
4		Cave, reused?		101	
13		Cave, reused?		101, 103	
14		Rock-cut chamber, reused	None attributable to period	116	
21		Cave, reused		74	
24		Abnormal shaft tomb, reused		48-50	
25		Cave, reused?	Indeterminable: 2 adults	103	
26		Cave, reused	None attributable to period	103	
28		Cave, reused?		103	
31		Cave, reused		106	
36		Cave, reused	None attributable to period	106	
40		Cave, reused		106	
42		Reused abnormal shaft tomb?		51	
47			Indeterminable	127	
48		Reused?		106	
50		Reused pit surrounded by masonry wall		54	
52		Reused		20	
59		Cave, reused?	Indeterminable	106-8	
63		Cave, reused?	Indeterminable	108-11	
73		Cave, reused	None attributable to period	111-13	
80		Rock-cut tomb, reused?	None found	127, 129	
217		Abnormal shaft tomb, reused	None attributable to period	31	
877		Abnormal shaft tomb, reused	None attributable to period except possibly 1 adult, perhaps full length, in B	33-36	
911		Normal shaft tomb, reused	2 adults full length, heads S., and 1 child in B; 2 adults full length, heads W., in C	64-68	
912		Abnormal shaft tomb, reused	None attributable to period	69-72	
989	Normal shaft tomb, reused	None attributable to period	40		
1122	Cave, reused	Indeterminable: 2 adults	18-20		
1250	Pit	None found	116		

TABLE I—Continued

Period	No.	Description	Position of Human Skeletal Remains	Page Reference
Iron Age	3	Cave with burial niches, reused		72
	11	Cave, reused	None attributable to period (excavation unfinished)	116
	14	Rock-cut chamber, reused	None attributable to period	116
	17	Rock-cut grave with overhanging ledge	1 adult full length, head WSW.	117
	27	Cave, reused?		127
	29	Reused abnormal shaft tomb?		117
	30			117
	31	Cave, reused		106
	37 B	Grave in cave floor	1 infant full length, head (missing) S.	77
	37 C 1	Grave with overhanging ledge, in cave floor	1 infant full length, head E.	77
	37 C 2	Jar burial in hole in cave floor	Indeterminable: 1 infant	79
	37 D?	Grave with overhanging ledge, in cave floor	None found	79
	37 K 1?	Burial in débris	Indeterminable: 1 individual	80
	37 O?	Grave with overhanging ledge, in cave floor	None found	81
	39	Abnormal shaft tomb, reused	None attributable to period	117-19
	41?	Abnormal shaft tomb, reused		29
	47			127
	52	Reused		20
	61?	Burial in débris	1 adult full length, head SW.	119
	62	Rock-cut grave with overhanging ledge	1 adult full length, head (missing) SW.	119
	71	Pit	1 adult full length, head SW.	121
	72	Burial in débris	Indeterminable: 1 adult	121
	73	Cave, reused	None attributable to period	111-13
	76	Reused abnormal shaft tomb?	None attributable to period	127
	80	Rock-cut tomb, reused	None found	127,129
	217	Abnormal shaft tomb, reused	None attributable to period	31
	221	Rock-cut tomb with shaft and steps and 4 chambers	Indeterminable	121,125
	237	Burial in débris	1 adult full length, head NNE.	126
	1090	Rock-cut tomb with steps and 3 chambers	Indeterminable: fragments in A; 8 adults in C	126
	1101 B	Rock-cut chamber, reused	Indeterminable	25 f.
	1101 C-D	Recesses in older rock-cut chamber	Indeterminable, but shape of recesses suggests full-length burials	26
	Roman	19	Rock-cut grave lined and covered with limestone slabs	Above: 1 adult, head NW., below: 1 child between 2 adults, heads SE., all full length
907?		Rock-cut grave	3 adults probably full length from shape of grave, heads W.	132
Uncertain	66	Rock-cut tomb	None found	132
	219	Rock-cut chamber	Indeterminable	87
	232‡	Grave with rubble walls and stone cover slabs	3 adults full length one above another, 2 heads WNW. and 1 ESE.	132
	236§	Rock-cut grave with cover slabs	1 adult full length, head SSW.	133
	854	Rock-cut and stone grave with cover slabs	Indeterminable	134
	857	Rock-cut and stone grave with cover slabs	1 adult full length, head SW.	134
	950	Burial in débris	1 adult full length, head NW.	134

‡ LI or classical.

§ Earlier than MI.

|| EI or later.

## IV

### SOME CHARACTERISTICS OF THE SUCCESSIVE PERIODS

By ROBERT M. ENGBERG

The purpose of this chapter is to consider characteristics of various periods at Megiddo, from Chalcolithic through EI I,<sup>1</sup> for the most part as revealed by objects found in its tombs (see Table V). The pottery is treated chronologically, whereas other types of objects are dealt with according to material or form. In this connection, analyses of copper and bronze objects have produced interesting results.

#### POTTERY VESSELS

##### CHALCOLITHIC (STAGES IV-VII)

In many respects the pottery from T. 903 Lower (Pls. 3 and 77-78) is typical of the late Chalcolithic period as already known from Megiddo<sup>2</sup> and thus constitutes a type group. Among more characteristic pieces are small red-wash bowls (e.g. Pl. 3:9), inner-ledge bowls (e.g. Pl. 3:15), gray burnished bowls (see Pl. 3:26 for shape and Pl. 77:12 for ware), bowls with conoid projections (Pl. 3:31-32), a hole-mouth jar (Pl. 3:36), spouted vessels (Pl. 3:34 and 49), and ledge handles (Pl. 77:1-11). All of these types were found throughout the more or less homogeneous strata of the east slope Chalcolithic deposit.

In general the Chalcolithic pottery is exceedingly well modeled for a handmade product. Only in the last phase of the period did wheelmade pottery appear. In the earliest stages firing techniques were poor, and the pottery was consequently unevenly and lightly baked. But with the introduction of the wheel (probably tournette) there came also new kiln devices that produced a uniformity of hardness and at times a strongly metallic quality which was lacking in the earliest pottery. Painted pottery was not characteristic of the Chalcolithic period, but solid washes were applied to most vessels. Grain-washing (see Pl. 77:15-20), so called because of its resemblance to grain in wood, was otherwise the only form of painting that became at all general. At the end of the period there appeared, along with other innovations, a new ceramic repertoire which is characteristic of the EB period but which was associated stratigraphically at first with the last of the Chalcolithic group. T. 903 Upper (above T. 903 Lower) yielded pottery representative of this transition (Pl. 3:3-4 and 8).

Since the foreign relationships and dating of the earliest ceramic products found at Megiddo have already been treated elsewhere,<sup>3</sup> here we restate briefly only the most significant conclusions. A connection with predynastic Egypt was recognized through the presence of spouted vessels (cf. Pl. 3:34 and 49) and hole-mouth jars with ledge handles (cf. Pl. 77:1-11). These forms have been recorded for Upper Egypt within the limits of the second Nakadah civilization (S.D. 38-63), but after about S.D. 53 ledge-handled jars developed in a way unknown to Palestine.<sup>4</sup> This differentiation indicates that contact between Egypt and Palestine existed more strongly before S.D. 53, but the relationship began after S.D. 38, at about which time

<sup>1</sup> Later material is not discussed here, but wherever possible parallels from the tell are cited in the plate descriptions.

<sup>2</sup> Cf. SAOC No. 10, in which are recorded the stratigraphic results of a small excavation on the east slope of the tell.

<sup>3</sup> SAOC No. 10, pp. 58-65.

<sup>4</sup> Cf. Petrie, *Corpus of Prehistoric Pottery and Palettes* (binder's title: *Prehistoric Egypt Corpus*; London, 1921) Pls. XXVIII-XXIX.

the ledge handle appears to have been introduced into Egypt. Comparison of Palestinian and Egyptian products should not prejudice our conception of the direction in which borrowing proceeded. Chalcolithic spouted forms appear to have been native to Egypt, but ledge handles seem to have been a Palestinian institution if we may judge by their prominence in that country and by the fact that forerunner types have now been found in Neolithic context at Jericho.<sup>5</sup> Further excavation in the Delta may produce additional evidence for their origin, but little is to be found in the material so far available. It is true that the Egyptian University excavations at el-Ma'adi, near Cairo, have produced two ledge handles<sup>6</sup> similar to Petrie's earliest, which belongs to S.D. 40,<sup>7</sup> but their scarcity and developed forms indicate that one must look elsewhere for their origin. Menghin and Amer suggested the eastern Delta or Syria.<sup>8</sup> Meanwhile the dominant position of the ledge handle in Palestine and surrounding territories is well attested.<sup>9</sup>

Another pottery type from T. 903 Lower, gray burnished ware, demonstrates the widespread ramifications of the Chalcolithic culture as seen at Megiddo.<sup>10</sup> A similar fabric has been found in "Neolithic" context at Malta; and form, color, and burnished finish are represented in "Middle Neolithic" Crete and "Neolithic" Rhodes.<sup>11</sup> Minoan chronology, based as it is on the Egyptian, indicates a predynastic date for the gray burnished vessels. This type of pottery has also been found sporadically at Tell Abu Zureik,<sup>12</sup> a few miles north of Megiddo; at Beisan,<sup>13</sup> at Affulah,<sup>14</sup> at Tell Mantah and Tell Handakuk in the middle Jordan Valley, Transjordan; and in the sea cliff at Byblos.<sup>15</sup>

Bowls with conoid projections, known from Megiddo (Pl. 3:31-32) and Beisan,<sup>16</sup> have few possible foreign parallels, but one from Badari seems to embody a relationship.<sup>17</sup> The similarity of the knobs and their placing around the rim are strongly reminiscent of the Megiddo type. Another specimen from Egypt was found in a predynastic grave.<sup>18</sup>

At the time of excavation we believed we had found the earliest deposits of the Chalcolithic period in northern Palestine, but subsequently FitzGerald dug a deep section into the tell at Beisan and there found one stratum and pits in virgin soil underlying his earliest ledge handles.<sup>19</sup> What the absolute dates of these oldest deposits are it is impossible to state at the pres-

<sup>5</sup> See I. Ben-Dor in *AAA* XXIII (1936) 87.

<sup>6</sup> Oswald Menghin and Mustapha Amer, *The Excavations of the Egyptian University in the Neolithic Site at Maadi. First Preliminary Report (Season 1930-31)* (Egyptian University, Faculty of Arts, "Publication" No. 19 [Cairo, 1932]) pp. 26 f. and Pl. XXXII 3-4. Ledge handles are not mentioned *ibid.* *Second Preliminary Report (Season 1932)* (Cairo, 1936).

<sup>7</sup> Petrie, *op. cit.* Pl. XXVIII 1.

<sup>8</sup> *First Preliminary Report*, p. 27. See also A. Scharff in *ZAS* LXXI (1935) 91.

<sup>9</sup> For distribution of the ledge handle in Palestine, Transjordan, and Syria as far north as Byblos see *SAOC* No. 10, p. 16, n. 1.

<sup>10</sup> *Ibid.* pp. 61 f.

<sup>11</sup> *Ibid.* p. 61, n. 14. Albright in *JPOS* XV (1935) 206 makes further correlations, including Hamah; but Frankfort, after handling our gray burnished ware, disagrees with Albright's contention that it has appeared in Uruk contexts.

<sup>12</sup> By P. L. O. Guy.

<sup>13</sup> FitzGerald in *MJ* XXIV (1935) 9.

<sup>14</sup> See E. L. Sukenik in *PEFQS*, 1936, Pl. I 1-6 (opp. p. 154).

<sup>15</sup> *SAOC* No. 10, pp. 61, n. 15, and 62.

<sup>16</sup> *MJ* XXIV 11. Cf. also a knobbed fragment from Jericho (FitzGerald in *AAA* XXIII 94 and Pl. XXXVII 12).

<sup>17</sup> G. Caton-Thompson in *Ancient Egypt*, 1928, p. 82 and Pl. IX 3 (p. 86).

<sup>18</sup> Georg Möller, *Die archäologischen Ergebnisse des vorgeschichtlichen Gräberfeldes von Abusir el-Meleq*, bearbeitet von Alexander Scharff (*WVDOG* XLIX [Leipzig, 1926]) Pls. 21, No. 156, and 41, No. 5. Petrie also has recorded this form from Egypt, but it is undated (*Corpus of Prehistoric Pottery and Palettes*, Pl. XV 5 a).

<sup>19</sup> *MJ* XXIV 6-8.

ent time, but it seems certain that they must be placed at least as early as the first part of the 4th millennium.

The Beisan stratigraphy produced an excellent series of pottery types which varies somewhat from that found at Megiddo but which nevertheless points to a comparable ceramic development at both sites after the earliest periods represented at Beisan. Gray burnished ware and indented ledge handles were roughly contemporary at Beisan,<sup>20</sup> a fact which agrees with the situation as found in the Megiddo Chalcolithic. At both sites these forms were followed or overlapped by types representative of EB. We agree, then, with FitzGerald in the approximate synchronism of Beisan Level XIV and Megiddo Stage IV; but Megiddo Stage V, in which no EB types (i.e., no types characteristic of Stages I–IV) were noted, seems earlier than the beginning of Beisan Level XIV, in which such types were found.<sup>21</sup>

The Beisan stratum most likely to have been contemporary with the lowest at Megiddo (Stage VII) may well be Level XVII, in which both gray burnished ware and indented ledge handles were apparently introduced.<sup>22</sup> That would leave Level XVIII and the pits in virgin soil as older than any of the stages found at Megiddo. Perhaps these lowest occupational levels at Beisan have their counterpart at Megiddo in a sterile but man-made deposit which lay below Stage VII.<sup>23</sup>

The remarkable stratification at Jericho,<sup>24</sup> which now places the Ghassulian culture beyond chronological doubt, thus confirming Albright's long held opinion,<sup>25</sup> carries Palestinian prehistory, step by step, back into the realm of the Stone Age before pottery was used. Our present interest, however, lies in the relationship between Jericho and the Chalcolithic at Megiddo. We have not seen the new Jericho material, but as in other matters we have broached the subject to Mr. Shipton, who agrees with Garstang in making Jericho E.B.A.i roughly equivalent to our Chalcolithic.<sup>26</sup> We both disagree with Garstang's tentative dating of the Megiddo Chalcolithic<sup>27</sup> and consider that comparison with Egyptian material justifies an earlier date (cf. p. 147).

The dating of the upper limit of the Megiddo Chalcolithic period is dependent on analogies of early ceramic specimens of the EB period with products from the 1st dynasty tombs at Abydos (see p. 147) and on the ultimate disposition of Mesopotamian cylinder seal impressions on pottery found in Stage V at Megiddo.<sup>28</sup> Thus far the best stratigraphic parallels for the seal impressions have come from Early Dynastic deposits in Mesopotamia, but in placing the Megiddo specimens in the early part of the Early Dynastic period we have noted that they have affinities with the Jemdet Nasr artistic tradition.<sup>29</sup> Further excavation in the Tigris-Euphrates country should allow a more definite allocation of the Megiddo cylinder seal impressions. Until such information is available we must be content with the possibility that the Chalcolithic period ended somewhere around 3000 B.C.

<sup>20</sup> *Ibid.* p. 21.

<sup>21</sup> *Ibid.* p. 22.

<sup>22</sup> Against this see *ibid.* pp. 21 f.; Albright in *JPOS* XV 200; and G. Ernest Wright, *The Pottery of Palestine from the Earliest Times to the End of the Early Bronze Age*, p. 42 and Table of Related Deposits II. Wright's work, which carries correlation a long step forward, is invaluable for the early chronology. We believe, however, that further excavation at Megiddo may conceivably add new Chalcolithic forms which would upset our present ideas on typology. The variety of gray burnished rim forms from Megiddo (Pl. 3:22–30) suggests that the carinated bowl cannot yet be considered as the only form typical of that ware at Megiddo.

<sup>23</sup> See SAOC No. 10, Fig. 1 and p. 6.

<sup>24</sup> See John Garstang, J. P. Droop, and Joan Crowfoot in *AAA* XXII (1935) 143–84.

<sup>25</sup> See e.g. *BASOR* No. 42 (April, 1931) pp. 14 f. and No. 48 (Dec., 1932) pp. 10–13.

<sup>26</sup> *AAA* XXII, Pl. XLVI. Cf. also Wright, *op. cit.* Table of Related Deposits II.

<sup>27</sup> *AAA* XXII, Pl. XLVI. <sup>28</sup> See SAOC No. 10, pp. 31–39; *PEFQS*, 1934, pp. 90–93. <sup>29</sup> SAOC No. 10, p. 37.

Our attribution of the seal impressions has been questioned by Christian,<sup>30</sup> who considers them as Jemdet Nasr in date, and by Albright,<sup>31</sup> who compares them to seals of the Uruk and Jemdet Nasr periods. We still feel that our stratigraphic parallels are valid,<sup>32</sup> as does Frankfort; an added argument is the fact that at Tepe Gawra no cylinder seals earlier than late Jemdet Nasr times have been found.<sup>33</sup> This is hardly conclusive in itself, but it nevertheless seems unlikely that cylinder seals would have reached Palestine from Babylonia before affecting Assyrian territory. The situation at Tepe Gawra tends to exclude the Uruk period from consideration. On the other hand, should the seal impressions from Megiddo Stage V prove to be of late Jemdet Nasr date, the Egyptian 1st dynasty indications for Stage IV (see p. 147) would present a perfectly rational chronology.

## EARLY BRONZE (EB)

## STAGES I-IV

Pottery of Stages I-IV was poorly represented in the tombs, the majority of it coming from T. 52 and T. 1106 (see Pls. 6 and 85). We may thus, as with Chalcolithic remains, draw fuller information from the stratigraphic record of the east slope.<sup>34</sup> With the exception of a few vestigial forms it is clear that a new culture was present, for the pottery products of this period differ markedly from those of the preceding period. This is attested by the appearance of new forms which were wheelmade (probably by a tournette), better furnace devices, and a consequent evenness in firing that was impossible with the limited facilities of Chalcolithic times. As a result the new ceramic types tended toward extreme uniformity. Several of these are illustrated from T. 52 and T. 1106: a platter-shaped vessel (Pl. 6:8); a late type of hole-mouth jar (Pl. 6:13); and a jug (Pl. 6:5). Other EB forms appear among the pottery from T. 1101-2 Lower (e.g. Pls. 6:18-19, 21, 24; 7:4-7; see also p. 147). A very important pottery accessory, the pushed-up ledge handle, is not illustrated by the tomb material, but as found in the stratified deposit near by<sup>35</sup> it proved to be a form intermediate between Chalcolithic and MB I types. One of the most interesting aspects of EB ceramics is the strong development of painted pottery (e.g. Pl. 6:1 and 3-4),<sup>36</sup> which was noticeably absent in the Chalcolithic deposits.

Stratigraphically Megiddo Stages IV-I seem to find their correlative in Levels XIV and XIII at Beisan, if we judge by ledge-handle types. In the earlier stratum at Beisan (Level XIV) the pushed-up ledge handle was introduced and appeared with the last representatives of the earlier, indented ledge handle.<sup>37</sup> This parallels the situation in Stage IV at Megiddo. The pushed-up ledge handle persisted through Level XIII at Beisan<sup>38</sup> and through Stage I at Megiddo. Immediately subsequent deposits at both sites contained the folded (or envelope) ledge handle, which is characteristic of MB I at Megiddo. A very possible equation would then appear to be: Beisan Levels XIV-XIII = Megiddo Stages IV-I.<sup>39</sup> In addition it should be noted that bowls with in-turned rims (e.g. Pl. 3:4) and bowls with pattern burnishing appeared in Stage IV at Megiddo<sup>40</sup> and in Level XIV at Beisan.<sup>41</sup>

<sup>30</sup> *Wiener Zeitschrift für die Kunde des Morgenlandes* XLII (1935) 138.

<sup>31</sup> *JPOS* XV 207.

<sup>32</sup> See now Scharff in *ZAS* LXXI 103.

<sup>33</sup> See E. A. Speiser, *Excavations at Tepe Gawra I* (Philadelphia, 1935) 120 and 183.

<sup>34</sup> *SAOC* No. 10, pp. 43-44, Fig. 8, and chart.

<sup>35</sup> *Ibid.* Fig. 5 B and chart, col. 14 B.

<sup>36</sup> See also *ibid.* Fig. 3, Nos. 4 A, 5 B, 7 A, Fig. 8 N-S, and chart, cols. 5-8.

<sup>37</sup> *MJ* XXIV 21.

<sup>38</sup> *Ibid.*

<sup>40</sup> See *SAOC* No. 10, chart, cols. 22 B and 1 E.

<sup>39</sup> A slightly different interpretation is given by Wright, *loc. cit.* <sup>41</sup> *MJ* XXIV 21.

A survey of the pottery from Stages IV–I at Megiddo reveals types that have important bearing on the foreign relationships and dating of EB. Comb-decorated pottery,<sup>42</sup> introduced during Stage IV, the stage of transition between Chalcolithic and EB, is comparable to pieces discovered at Khirbet Kerak,<sup>43</sup> under the temple at Byblos,<sup>44</sup> and in 1st dynasty royal tombs at Abydos.<sup>45</sup> From Stages III–I came two pottery types<sup>46</sup> that are strongly suggestive of a jug type from the 1st dynasty tombs at Abydos.<sup>47</sup> This particular jug type has been considered as one of a number of foreign intrusions in the Abydos tombs.<sup>48</sup> Quite possibly Palestine was its source, for the Megiddo specimens cited are comparable to others found in Palestine.<sup>49</sup> When we consider also the Mesopotamian cylinder seal impressions found in Stage V of the Megiddo Chalcolithic deposit (see p. 145) there is evidence to suggest a date of about 3000 B.C. for the inception of EB.

The absence of Khirbet Kerak ware at Megiddo except in one unstratified instance (see T. 9, p. 20) is puzzling and remains to be explained.

#### STAGE 0–I

Stage 0–I represents the end of the EB period at Megiddo and was present only in the associated groups from T. 1101–2 Lower (see p. 26 and Pls. 6–7), which contained pottery obviously linked to the EB tradition<sup>50</sup> but regarded as somewhat later than Stages IV–I because of more fully developed pieces present with it. Partially folded ledge handles for instance (see Pl. 7:2–3) are intermediate in form between the pushed-up ledge handles typical of Stages IV–I (see p. 146) and the fully folded ledge handles of the MB I period (see p. 148). Other specimens from these tomb groups (Pls. 6:17, 22–23, 27–31; 7:1–3, 8–9, 13–15) must likewise be considered later than Stages IV–I, although clearly related, for, since we are dealing with a homogeneous deposit, all of the pottery in it is dated by the latest types.

The Stage 0–I pottery seems to be entirely local in character, not only because parallels outside of Palestine are lacking but because the nature of the known pieces links them to conceptions typical of the EB period in Palestine. While some of the pieces noted are new and impart a peculiar flavor to the Stage 0–I ceramics, they all contain derivative elements the sources of which are clear.

At Tell Beit Mirsim the completely folded ledge handle and pinched lug handle are found in Stratum I<sup>51</sup> and not in Stratum J. The Stage 0–I material of Megiddo, which is characterized by the partially folded ledge handle, clearly a typological predecessor of the fully folded form, and the first pinched lug handles (see Pl. 7:1 and 14–15), should thus find its position somewhere between Tell Beit Mirsim I and J. In view of the many hold-over forms from earlier in the EB period the T. 1101–2 Lower deposit is probably nearer Stratum J in point of time.

In this volume approximately 2000 B.C. has been tentatively adopted as a convenient and

<sup>42</sup> SAOC No. 10, Fig. 8 E.

<sup>43</sup> Albright, AASOR XII 5.

<sup>44</sup> For this and other EB parallels between Byblos and Megiddo see SAOC No. 10, p. 64, n. 19.

<sup>45</sup> Petrie, *The Royal Tombs of the First Dynasty* I (London, 1900) Pl. XXXVIII 9.

<sup>46</sup> SAOC No. 10, chart, col. 11 A–B. The absence of these two types in Stage IV is not yet conclusive, inasmuch as somewhat similar metallic wares appeared in Stage IV (*ibid.* col. 22 B).

<sup>47</sup> Petrie, *Abydos* I (London, 1902) Pl. VIII 4. See also Petrie, *The Royal Tombs of the Earliest Dynasties* II (London, 1901) Pl. LIV, and Frankfort, *Studies in Early Pottery of the Near East* I (London, 1924) Pl. X 1 b (opp. p. 106).

<sup>48</sup> Petrie, *The Royal Tombs of the Earliest Dynasties* II 46, and Frankfort, *op. cit.* pp. 107 f.

<sup>49</sup> Cf. Garstang in AAA XIX (1932) Pls. I 6 and III 21 for specimens from Jericho. For a discussion of the source of this type see Wright, *op. cit.* pp. 69–72.

<sup>50</sup> From Stages I and II came pithos rims and bases (see SAOC No. 10, p. 56) similar to Pl. 7:6 and 11. More generally represented throughout Stages IV–I were vessels like Pls. 6:18–19, 21, 24–26 and 7:4–5, 7, 10.

<sup>51</sup> AASOR XII, Pl. 3, Nos. 22–23 and 38–40; XIII, Pl. 20, Nos. 17–19.

reasonably close date for the end of EB. Considering the fact that the placing of EB deposits in Palestine is still subject to evidence that may be faulty or not too clear we gladly refer the reader to Wright's excellent monograph, where evidence for dating the end of the EB period and the various subdivisions within the period is well treated.<sup>52</sup> The last stage of EB (Wright's EB IV) should coincide fairly well with the first intermediate period of Egypt, although it is to be noted that no stamp seals typical of the Nile Valley of that time have apparently ever been found in Palestine. This dating is somewhat earlier than that previously ascribed to Stage 0-I.<sup>53</sup>

#### MIDDLE BRONZE I (MB I)

The material from this period is so abundant and well preserved that several conclusions are immediately apparent. The EB ceramic tradition at last came to an end. New products, some of them probably imported from Syria, made their appearance. New traits, more typical of the Hyksos, first come to notice.

Easily recognized as an EB survival is the fully folded ledge handle (e.g. Pl. 10:9-10), which brings to an end a conception begun in Chalcolithic times. Another manifestation of EB influence is the flat base seen in most MB I vessels (see e.g. Pls. 10-12); the ring base did not appear until MB II times. Painted vessels from T. 1098 (Pl. 21:8-10) are decorated in a manner reminiscent of the EB period.

New types of local manufacture include handmade "teapots" with one or two lug handles (e.g. Pls. 12:14, 20:15, and 21:16) and red ribbon-handled jugs with long necks (Pl. 11:21-25), which occasionally occur without a handle (Pl. 11:19-20). These are not to be confused with a somewhat similar but much earlier type of pot found at Byblos.<sup>54</sup> Other characteristic pieces are jugs like Nos. 17-18 on Plate 21 and jars with pinched lug handles (e.g. Pl. 22:14) clearly related to the "teapots" (see below).

In some respects the most important pottery type of the period is one which we have regarded as an import. It includes a group of wheelmade "teapots" and cups which are generally dark in color and decorated with light horizontal bands and spirals, zigzags, or continuous curves (e.g. Pls. 10:5; 11:26-27, 30-33; 22:3, 19; and 33:10). The variations in color of surface are due not to differences in material but to differences in the degree of firing. The spouts of the "teapots" were cut with a knife before firing. The method of spout attachment is illustrated by Plate 11:28 and 31. Strangely enough, this type of ware, which is thin and metallic, has been found nowhere else in Palestine as far as we know; but several sites in Syria have yielded numerous pieces which are comparable in so many respects that with little hesitancy we may consider that country as the place of origin.<sup>55</sup> Comte du Mesnil du Buisson in the course of several seasons' excavations in central Syria dug at el-Mishrifé (ancient Qatna), Tell 'Adah, Dnébi, Khan Sheikhun, and Tell 'As, where he found "teapots" and cups resembling the Megiddo vessels.<sup>56</sup> Aside from identity in shape there is such complete agreement in other details that it would be difficult not to see some connection. Similarities noted consist of the following: the solid bases of the cups, the splayed bases of the tall goblets, the absence of handles, the form and position of the spout, the type of gutter around the inside of the "teapot" rims (Pl. 15:1 and 6-9), the concave profile of the "teapot" bases, identical wheel markings. In the Syrian vessels there is no real parallel for the Megiddo decoration, but at times there is a decorative attempt consisting of closely set white horizontal lines. Other factors which point to an

<sup>52</sup> *Op. cit.* p. 81 and *passim*.

<sup>53</sup> See SAOC No. 10, pp. 52-58, where it was regarded as early 12th dynasty.

<sup>54</sup> Pierre Montet, *Byblos et l'Égypte* (Paris, 1928-29) Pl. CXLIV 906-9.

<sup>55</sup> Cf. SAOC No. 10, pp. 71-74.

<sup>56</sup> *Syria* XI (1930) Fig. 6 (p. 161) and Pls. XXXI, XXXIII, and XXXV; XIII (1932) 177 f. and Pls. XXXVI and XXXIX.

intermediate element between Syrian and Megiddo pieces include finger-molded spouts and a frequently occurring white ware among the Syrian products. Neither of these characteristics has been noted at Megiddo.<sup>57</sup> The Syrian products have been dated by the excavator to about the beginning of the 2d millennium B.C.<sup>58</sup>

Another Syrian site, somewhat removed from the inland excavations already mentioned, has produced from an early deposit a few decorated sherds of "teapot" fabric.<sup>59</sup> This site, Byblos, lying by its small harbor on the Mediterranean coast, indicates through the presence of these few sherds a rather widespread development of the "teapot" and cup types in Syria. The strong resemblance between the Byblos and Megiddo decorative forms opens the possibility of the coast being the particular part of Syria responsible for the distribution of this new ware to Megiddo. With a thus widening field of operations for these products one must consider the Early Minoan III and Middle Minoan I light-on-dark wares of Crete, although at best there seems to be no more than a remote artistic influence involved. In the Minoan vessels shape, type of beaked spout, presence of handles, and manner of painting preclude serious comparison; but there may be some significance in the light-on-dark conception in which horizontal bands frame curvilinear patterns. Also of possible importance is the distribution of this ware in Crete, for it is found only in the eastern part of the island—for instance at Mochlos, Gournia, and the Kamares Cave.<sup>60</sup> This in itself is suggestive of contact with territory to the east.

Several new traits in the MB I pottery are typical of the Hyksos age, which followed. Two jugs (Pls. 22:9 and 33:9) have pinched lip, a trait common with Hyksos pottery. The button-like base and the shoulder of the former also look ahead in time and make this jug comparable to late Hyksos vessels (cf. e.g. Pl. 48:17). This jug and the bowl found with it (Pl. 22:8) are probably as late as any of the pre-Hyksos material so far considered. Another new pottery type, indistinguishable from its MB II relatives, is the lamp with slightly pinched lip (Pls. 10:27 and 12:10-11). The four-lipped lamp (Pl. 10:28)<sup>61</sup> also appears for the first time in the MB I period. In fact, lamps have not been definitely recognized in the preceding periods.<sup>62</sup>

The MB I pottery of Megiddo, most of it from shaft tombs, which are typical of this period only, find good stratigraphic parallels at Tell Beit Mirsim. The most recent excavation of the earlier strata there reveals that fully folded ledge handles (see p. 148) are restricted to Stratum I.<sup>63</sup> Its synchronism with the Megiddo shaft tombs is thus clearly established.

Applying absolute dates to the MB I period appears to be as hazardous a procedure as ever, for, while good chronological sequences have been established, little evidence has been discovered by which actual time labels may be attached. Admitting a cultural break between what is here classed as MB I and the first truly Hyksos material, we remain in the position of not knowing what length of time is represented by the change. Certain relationships in pottery and metal have been noted between the Hyksos and pre-Hyksos material at Megiddo;<sup>64</sup> while such observations are not conclusive in themselves, they suggest a rather close time relationship as well. Perhaps, then, the products we have classed as MB I did not precede the MB II period by long. It seems quite probable that they can be dated early in the 2d millennium. On the other hand, Albright places Stratum I at Tell Beit Mirsim, with which we have correlated our MB I burials, as early as about the 21st century.<sup>65</sup>

<sup>57</sup> Cf. *SAOC* No. 10, pp. 71 f.

<sup>58</sup> *Syria* XIII 178.

<sup>59</sup> Examined by P. L. O. Guy and G. M. Shipton.

<sup>60</sup> Sir Arthur Evans, *The Palace of Minos at Knossos* I (London, 1921) 108 ff. and 164; see also *SAOC* No. 10, p. 73.

<sup>61</sup> See J. L. Starkey in *PEFQS*, 1934, Pl. III 2, for an approximately contemporary four-lipped lamp from Tell ed-Duweir.

<sup>62</sup> But see *SAOC* No. 10, p. 19, bowl 20 A.

<sup>64</sup> *SAOC* No. 10, pp. 75-77.

<sup>63</sup> Albright in *AASOR* XIII 62.

<sup>65</sup> *JPOS* XV 219.

In the pottery recovered from MB I deposits at Megiddo there is apparently nothing that can be tied up with the renewed interest in Asia of Egyptian 12th dynasty rulers. Such indications remain largely literary and have practically no archeological support in Palestine at least, except for some Egyptian Middle Kingdom statues found at Megiddo<sup>66</sup> and Gezer<sup>67</sup> and three scarabs from Megiddo with possible Middle Kingdom names (Pls. 105:2, 13; 116:8).

#### MIDDLE BRONZE II (MB II)

There is general agreement in the field of Palestinian archeology that the appearance of the so-called Tell el-Yahudiyyah jug type (e.g. Pl. 23:23)—piriform in shape, with button base, and often colored black with a chalky inlay—marks the beginning of the MB II period.<sup>68</sup> Other pottery types, practically all wheelmade, are equally valuable in the delineation of MB II, though some of them continue on into LB I (see p. 151). The MB II ceramic repertoire is much greater than that of any of the preceding periods. In view of the distinct stylistic changes noted in the majority of vessels we are assured that a new culture and people are represented, and we assume that the changes were due to the Hyksos. For pottery types illustrative of the MB II period at Megiddo see Plates 23–29, 31, and 35.

A jug type with flat or slightly rounded bottom (e.g. Pls. 25:11; 27:1–2, 18) and frequently dark in color, usually with double handle, appears now for the first time; it is related to the Tell el-Yahudiyyah jug. Contemporary with it was another type of jug, always dark, with handle springing from the neck (e.g. Pl. 27:9). Their histories were not completed until the LB I period. The double handle (e.g. Pl. 23:26 and 28) is in itself a useful landmark for both MB II and LB I, and triple handles (e.g. Pls. 23:15; 28:44, 47) and quadruple handles (e.g. Pl. 28:45–46) as seen in MB II tombs seem to be characteristic of the period. Still another distinctive type of handle is that which is placed on the shoulder (e.g. Pls. 23:19; 24:4, 18; 25:4–5, 19). Small juglets like Nos. 15–17 on Plate 25, though somewhat similar in shape to LB II (e.g. Pl. 16:25–28) and later specimens, are distinguishable by their ware; moreover, the earlier jugs are better fashioned and seldom have the accentuated lip typical of the later specimens. Peculiar to the MB II period are wide-rimmed bowls, usually with red wash over the rim (e.g. Pls. 23:12 and 28:1–21), and jugs like Nos. 44–47 on Plate 28 and Nos. 18–21 on Plate 31. Some of these jugs (e.g. Pls. 28:45, 47; 31:20) are covered with a burnished dark red wash, a type of treatment that appears to date to the 19th century on the tell.<sup>69</sup> Carinated bowls with pedestal base (e.g. Pls. 23:2 and 26:11–12), often finished with a finely levigated light slip, appeared first in MB II; still other characteristic bowls are to be seen on Plates 23 (Nos. 8–10) and 24 (Nos. 8 and 13). Large jars are better represented in town deposits, but an excellent example from the tombs is No. 6 on Plate 24.

Lamps conform to a type which apparently was introduced to Megiddo in MB I times (see p. 149) and lasted until LB I. They consist essentially of a simple vessel with rounded bottom and pinched lip (e.g. Pl. 23:14) and do not have rims, as do lamps from the LB II (e.g. Pl. 20:6) and later periods.

Although painting is by no means characteristic of the MB II period, there are a few examples which demonstrate a painting tradition quite different from any noted in earlier tombs. A design with crossed bands painted on the interior of bowls (see Pl. 25:13) seems to carry on

<sup>66</sup> Gordon Loud in *ILN*, June 20, 1936, p. 1108 and Fig. 2.

<sup>67</sup> Macalister, *Gezer II* 311–13.

<sup>68</sup> Albright suggests the possibility of a forerunner type, found in Stratum H at Tell Beit Mirsim, for the Tell el-Yahudiyyah jug (*AASOR XIII* 65 f. and Pl. 3, No. 13). It is fairly close in conception to MB II examples from Megiddo (e.g. Pl. 23:24–25).

<sup>69</sup> *AJSL LIV* (1937) 77.

into EI elsewhere in Palestine.<sup>70</sup> Strictly MB II is the combination of form and banded paint decoration of jugs like Nos. 2-5 on Plate 29 and Nos. 18-19 and 21 on Plate 31; but banded decoration in itself is very common in later periods (see p. 159). A Tell el-Yahudiyyah type jug seen on Plate 23 (No. 29) is decorated in a style unusual in Palestine.

Both Syria and Cyprus had relationships with Palestine in the MB II period, but the principal contact appears to have been with Syria, if we judge by the Megiddo tombs and other MB II deposits from Palestine. Indeed, a more or less common culture seems to have existed from Gaza, Gezer, Tell Beit Mirsim, and Jericho on the south<sup>71</sup> to Byblos, Ras Shamra, and Aleppo on the north.<sup>72</sup> This relationship existed not only in ceramics but in other kinds of objects as well (see pp. 164, 168-70, 186). The extent to which the two countries were dominated by the same Hyksos culture is perhaps best seen in a common type of child burial (see Fig. 60), which at Ras Shamra appears in the upper part of the second stratum.<sup>73</sup>

Cyprus in MB II times was just entering upon a long period of influence on the eastern Mediterranean coast. At Megiddo this is illustrated by the presence of a decorated handmade jug (Pl. 24:3) which is almost identical with a native Cypriote piece considered by Gjerstad as typical of his white painted V ware.<sup>74</sup> This ware was most plentiful during Middle Cypriote III (*ca.* 1750-1600 B.C.).<sup>75</sup>

#### LATE BRONZE I (LB I)

The principal ceramic traditions seen in the MB II tombs continued into the LB I period. Thus, even with the introduction of new pottery concepts, enough of the old was left for us to consider the two periods as closely related culturally; we view them both as Hyksos. The features which distinguish the LB I period are increased commerce with Cyprus, shown particularly in the importation of pottery; the use of "Hurrian" motifs on painted pottery of local manufacture and the two-color technique so common in their execution. Examples of such motifs have been so numerous in Palestine that it now seems necessary to view them as a sign of a separate ethnic movement. Megiddo pottery of the LB I period is shown principally on Plates 38-53. That from T. 1100 (see Pls. 45-48) forms a type deposit for the period.

Among the forms which appeared in MB II and extended on into LB I, but no farther (see p. 150), are shoulder handle jugs (see Pl. 46), juglets with slightly pinched lip (e.g. Pl. 143:15-21; cf. Pl. 25:15-17), dark jugs with handle springing from the neck (e.g. Pl. 45:20-21), and jugs with flat or somewhat rounded base and often a double handle (e.g. Pls. 47:11 and 48:18). A pellet on the handle of such jugs seems, however, to be peculiar to LB I. Pellets occur on other types of jugs also (see Pls. 46:5 and 48:17). Large jars (e.g. Pl. 52:1-2) embody earlier forms; and carinated bowls with pedestal base, usually finished with a light slip (e.g. Pl. 48:11-12), are very similar to MB II specimens. Lamps (e.g. Pl. 47:1) continue the simple tradition of earlier periods.

Certain vessels which have so far occurred in LB I only appear to be of value for the characterization of that period but because of their infrequency must be regarded as uncertain evidence. Such is a type of small, spouted bowl (e.g. Pl. 39:9), sometimes with painted decoration (e.g. Pl. 40:16). Another bowl type, of which only one specimen was found, has four

<sup>70</sup> Cf. Macalister, *Gezer* III, Pl. CLXXIII 4 and 6.

<sup>71</sup> See Petrie, *Gaza* II (1932) Pl. XXXIV, for Tell el-Yahudiyyah types; Macalister, *Gezer* III, Pls. XXXVIII-XLI; Albright in *AASOR* XIII, Pls. 8-9 and 15; Ernst Sellin and Carl Watzinger, *Jericho* (*WVDOG* XXII [1913]) Pls. 22 and 28-30 ("israelitische Tongefässe").

<sup>72</sup> Montet, *Byblos et l'Égypte*, Pls. CXXIV, CXLVI-CXLVIII; Schaeffer in *Syria* XIII, Fig. 12 (p. 18) and Pl. XII 3, and XIV (1933) Fig. 10 (p. 110). Piriform jugs, often painted after the manner of our Pl. 23:29, have been found in the Aleppo district and are now in the Aleppo Museum.

<sup>73</sup> Schaeffer in *Syria* XV (1934) Fig. 9 (p. 125). <sup>74</sup> Gjerstad, *Studies*, p. 172, jug 8. <sup>75</sup> *Ibid.* pp. 269-73 and 335.

holes for suspension near the rim (Pl. 47:3). Crude and heavily made bowls with spouts near the base (Pls. 37:7 and 49:22) are probably not later than LB I. Certain other types of bowls too, as far as we know, are typical of the period (see Pls. 37:1 and 3; 38:15-16; 40:17-18; and 45:5, 8, and 13-14). Small cooking bowls and larger ones with handles (e.g. Pl. 40:19) may constitute types for the period, but cooking bowls for the most part seem to lack chronological distinction. One jar (Pl. 47:4) was obviously made in imitation of a type of Egyptian "alabaster" jar (e.g. Fig. 184:2-3) characteristic of Hyksos deposits in Palestine (see p. 186).

A few pottery forms first observed among LB I tomb groups carried over into LB II (see p. 154). Jar-stands with two holes in the sides (e.g. Pl. 50:1) appeared for the first time in the earlier period but survived and flourished in later periods. One type of bowl (Pl. 37:11) and its variations persisted, in form at least, into the LB II period, when many ramifications of it occurred. Chalices appear to have been first introduced in LB I but in a form (see Pl. 58:24) not easily confused with those of later periods.

The designs on painted pottery of local manufacture include the following patterns:

- British union jack (Pl. 48:14)
- Maltese cross (Pl. 38:10)
- Plaiting (Fig. 111 and Pl. 45:18)
- Herringbone (Pl. 49:5)
- Hourglass (Pls. 38:12, 41:21, and 48:2)
- Lattice (Pls. 41:21 and 47:14-15 and 17)
- Checkerboard (Pl. 48:7)
- Triangle (Pls. 44:3, 46:14, and 53:2)
- Vertical or oblique lines below a horizontal band or between two horizontal bands (Pl. 41:2-10)<sup>76</sup>
- Zigzag lines between straight lines (Pls. 43:11, 44:3, and 48:1)
- Antithetic arrangement of birds and tree (Fig. 111).

Of these only the first three are limited to the LB I period at Megiddo, though the Maltese cross is common on EI pottery elsewhere in Palestine.<sup>77</sup> The others have been noted in later periods at Megiddo (see pp. 156 and 160), and there is one instance of zigzag lines between straight lines in MB II (Pl. 25:13). These facts, however, detract nothing from the value of the figures as criteria of the LB I period if we consider at the same time the two-color application (use of broad dark strokes to outline a lighter color; see front. and Pls. 46:15 and 48:14), the quality of the paint, and the general treatment, which are as characteristic of the designs of the period as the forms of the vessels on which they appear. Later adaptations of the designs will rarely be confused with those from the LB I period. Arrangement of patterns in metope style seems to begin in LB I (e.g. Pl. 41:21), though it is much clearer in later periods.

The antithetic arrangement of birds and tree is comparable to the religious and mythological figures which, with a central tree, are so prominent in Syro-Hittite and Assyrian art.<sup>78</sup> The design on our jug (Fig. 111) is distinctly LB I in its style of painting, but the general pattern of tree-of-life groupings was just entering upon a long and prominent history in Palestine.<sup>79</sup>

The two-color painting technique of the LB I period, involving the patterns listed above, has been found also at other sites in Palestine, particularly at Tell Ta<sup>c</sup>annak,<sup>80</sup> Gezer,<sup>81</sup> Tell ed-Duweir,<sup>82</sup> Tell el-Hasi,<sup>83</sup> and Tell el-<sup>c</sup>Ajul.<sup>84</sup>

<sup>76</sup> For an early 18th dynasty specimen see Petrie and Brunton, *Sedment* (London, 1924) II, Pl. LXIII 276 A (D).

<sup>77</sup> See Albright, *AASOR* XII 62 and Pl. 49, No. 5; Bliss and Macalister, *Excavations in Palestine*, Pls. 40, Nos. 113-16, and 44.

<sup>78</sup> For a fuller discussion see *OIP* XXVI 35-36.

<sup>79</sup> See *ibid.* Pls. XL-XLI.

<sup>80</sup> Sellin, *Tell Ta<sup>c</sup>annek* (Wien, 1904) Figs. 50 and 76.

<sup>81</sup> Macalister, *Gezer* II, Fig. 324.

<sup>82</sup> Starkey in *PEFQS*, 1933, p. 196.

<sup>83</sup> Bliss, *A Mound of Many Cities*, p. 62, No. 106.

<sup>84</sup> Petrie, *Gaza* II, Pl. XXXVIII.

Speiser has called attention to the similarity between designs on pottery (shapes not comparable) from the third stratum (*ca.* 1600–1400 B.C.) at Tell Billah in northern Mesopotamia and those in question from Palestine and neighboring districts and has labeled as “Hurrian” the culture characterized by these designs.<sup>85</sup> In so doing he has laid the foundation for the recognition of a widespread civilization which affected large parts of the Near East in the 2d millennium B.C. Among the more distinctive motives seen both at Tell Billah and in Palestine are the British union jack, the checkerboard, and Macalister’s “Amorite” bird.<sup>86</sup> Evidence of this “Hurrian” culture has appeared in Egypt also,<sup>87</sup> and traces of it can be detected here and there in Syria, where extended excavation should reveal much more material. Pieces which are undoubtedly related have been found at Minet el-Beida<sup>88</sup> and Ras Shamra,<sup>88</sup> at Chatal Hüyük<sup>89</sup> and Tell el-Judaidah,<sup>90</sup> and at Tell Atshanah.<sup>91</sup> It is notable that eastern Palestine, well explored at strategic points, has apparently not yielded pottery with the more characteristic “Hurrian” designs.

To place the correlation between northern Mesopotamia and Palestine during LB I on a still firmer foundation we may go beyond the realm of ceramics and adduce parallels in glyptic art as well. Cylinder seal impressions from the contemporary level at Nuzi have counterparts at Megiddo (see pp. 182–84).

The origin of “Hurrian” pottery designs is still uncertain. Speiser believes that they point to the west of Tell Billah and that possibly they embody Aegean elements.<sup>92</sup> When we consider the trend of the cultural movements of the time, the Palestinian and Egyptian examples point to a northern origin. Syria certainly seems nearer the source than Egypt, Palestine, or Mesopotamia.

The cultural relationships of the LB I period at Megiddo are primarily “Hurrian”; but in view of strong connections between MB II and LB I, indicated by weapon forms (see pp. 163 f.) and scarabs (see p. 185) as well as pottery, we must regard both periods as Hyksos. The terms “Hurrian” and “Hyksos” are not mutually exclusive. It was apparently the LB I, or later Hyksos, people who joined in the coalition against Thutmose III on his expeditions into Asia beginning in 1479 B.C. At Megiddo there is no trace of Egyptian Empire culture in the LB I tombs, whereas later tombs clearly show such influence (see pp. 177 f., 185).

Cyprus sent excellent handmade ceramic wares to Palestine in the MB II period (see p. 151), but in the period with which we are now dealing there was a great increase in the number of Cypriote imports. The excavations at Megiddo have produced many such pieces. Specimens of Gjerstad’s white painted V ware are more abundant in the LB I period (e.g. Pls. 38:6, 41:28, 43:5, and 45:19) than before (see p. 151).<sup>93</sup> One jug from Megiddo (Pl. 41:27) is apparently a specimen of his white painted IV ware.<sup>94</sup> Cypriote monochrome ware is represented at Megiddo by milk bowls with wishbone handles and hollow bases (Pls. 42:12–13 and 47:9).<sup>95</sup>

<sup>85</sup> *MJ* XXIII (1932/33) 273–75. Cf. *ibid.* Pls. LX 3 and LXIII–LXIV with *OIP* XXVI, Pl. XXXIX. For a full discussion of the Hurrian question see Speiser, “Ethnic Movements in the Near East in the Second Millennium B.C.” (*AASOR* XIII 13–54).

<sup>86</sup> Reproduced in *OIP* XXVI, Pl. XXXIX K, from Macalister, *The Philistines* (London, 1913) p. 121.

<sup>87</sup> Petrie and Brunton, *Sedment* I, Pl. XLV 67–68 and 71.

<sup>88</sup> See Schaeffer in *Syria* XIII, Fig. 7 (p. 11), and in *ILN*, April 27, 1935, p. 688, Figs. 12–13.

<sup>89</sup> See C. W. McEwan in *AJSL* LII (1935–36) 62.

<sup>90</sup> See McEwan in *AJA* XLI (1937) 10.

<sup>91</sup> See Sir Leonard Woolley in *ILN*, Oct. 9, 1937, pp. 604 f., for familiar “Hurrian” designs from this site.

<sup>92</sup> Speiser, *Excavations at Tepe Gawra* I 161.

<sup>93</sup> Cf. Gjerstad, *Studies*, p. 172, jugs 4 (1st) and 8.

<sup>94</sup> Cf. *ibid.* p. 169, jug 1. For a similar specimen from the Second Semitic period at Gezer see Macalister, *Gezer* III, Pl. LXII 51.

<sup>95</sup> Cf. Gjerstad, *Studies*, p. 183, bowl 1.

This type of ware seems to have come into use in the island in the Late Cypriote I period (*ca.* 1600–1400 B.C.).<sup>96</sup> Other milk bowl varieties found at Megiddo, perhaps slightly later in date, include a type with spout and simplified wishbone handle (Pl. 42:14), another embodying base-ring ware characteristics (Pl. 49:24),<sup>97</sup> and one which is clearly an early specimen of Gjerstad's white slip ware (Pl. 49:23),<sup>98</sup> destined to be much more important in LB II times (see p. 158). An occurrence of base-ring ware in Egypt, possibly pre-Empire, has been noted at Sedment.<sup>99</sup> At Megiddo such ware is represented also by bilbils (Pls. 43:6–8, 47:13, and 50:11), a jug with wide mouth (Pl. 50:12), and a flask (Pl. 43:13).<sup>100</sup> Decorative patterns include curvilinear raised relief and light painted bands. Although base-ring ware seems to be principally an LB II product in Palestine (see p. 158), these specimens were found in well defined LB I contexts.

Importations from Cyprus and "Hurrian" designs on pottery of local manufacture are innovations which by the number of specimens found characterize the LB I period at Megiddo. There remains to be considered one specimen (Pl. 48:3) which falls into neither class. The form and two-color application of its pattern strongly suggest a relationship to the "Hurrian" class, but its ware is different from others of the period. A jug comparable to it in form and elements of decoration is illustrated by Gjerstad,<sup>101</sup> who recognized it as foreign to Cyprus. His tentative designation of Syria as the country of origin may well prove to be correct.

#### LATE BRONZE II (LB II)

Most of the pottery types characteristic of the LB I period had disappeared by LB II times, and those that remained were modified to such an extent that a mistaken attribution is unlikely. LB II pottery has a stamp of its own that tends to segregate it from representatives of both the preceding and the following period, although the latter were largely dependent on LB II forms (see p. 159). The LB II groups from Tombs 877, 989 (see Pls. 12–20), 911 (see Pls. 30–32), and 912 (see Pls. 33–36) may be considered as type deposits for the period. Cypriote and Mycenaean imports, the latter newly arrived, indicate considerable Mediterranean traffic, probably with the fifth city at Tell Abu Hawam, near Haifa, as the port of entry.<sup>102</sup> Today, as in antiquity, the normal northward approach from Megiddo to the sea lies along the edge of the Plain of Esdraelon, through the Kishon Pass, and thence into the Plain of Acre along the base of the Carmel Ridge. In following this route one reaches Tell Abu Hawam. Egypt seems to have had little influence on pottery styles, although there are signs of reaction to the Nile culture in other types of objects (see pp. 177 f., 185).

Among the few types of pottery vessels surviving from LB I (see p. 152) are carinated bowls (e.g. Pl. 16:5), which, however, were subject to the poorer technique of the period and are accordingly easily recognized as LB II products. Jar-stands (e.g. Pls. 35:20, 56:1–2, 58:19, and 65:21) and chalices (e.g. Pls. 16:9–10, 34:11–12, 57:8, 59:13, and 60:4–5 and 30) might in a sense be considered survivals but were in fact only reaching a fuller importance in the LB II period.

Unpainted bowls of the period, though simple in form and generally carelessly thrown on the

<sup>96</sup> *Ibid.* pp. 278 f.

<sup>97</sup> Cf. John L. Myres, *Handbook of the Cesnola Collection from Cyprus* (New York, 1914) p. 40, No. 361.

<sup>98</sup> Gjerstad, *Studies*, p. 195, bowl 2 (2d).

<sup>99</sup> Petrie and Brunton, *Sedment I*, Pl. XLV 65 (attributed to the 16th dynasty). See also Albright's discussion in *AASOR XII* 25–27 regarding the early importation of base-ring types into Egypt and Palestine.

<sup>100</sup> Cf. Gjerstad, *Studies*, p. 186, jugs 1 and 2 (1st and 3d), and p. 187, jug 9 and flask 1.

<sup>101</sup> *Ibid.* p. 205, No. 6. There have just come to our attention three closely comparable vessels from Melia in Cyprus; see Schaeffer, *Missions en Chypre* (Paris, 1936) Pl. XXVII and pp. 50 ff.

<sup>102</sup> Cf. R. W. Hamilton in *QDAP IV*, Pls. XVI–XVII and XXII.

wheel, are quite distinctive (see Pls. 15:14–16, 32:12–21, and 36:1–5). Many of them have flat rather than ring bases. Though cooking bowls seem to lack datable characteristics, we call attention to varieties found in LB II tombs (see Pls. 16:7, 20:9, 36:7–8, and 54:2 and 8–11).

Jars show a greater variety of form than was known in preceding periods. There are specimens, both large and small, with handles rather low on the body (e.g. Pls. 18:1–2 and 12:23). Storage jars with rounded or large button base and flat shoulders (e.g. Pl. 17:13–14) are characteristic of the period. They have been found at other sites in Palestine<sup>103</sup> as well as at Minet el-Beida<sup>104</sup> and Tell el-<sup>c</sup>Amarnah.<sup>105</sup> The Tell el-<sup>c</sup>Amarnah vessels are sometimes decorated in blue. A jar type which may possibly be of Egyptian origin is seen on Plates 57 (Nos. 9–10) and 154 (No. 6). The excavations at Tell el-<sup>c</sup>Amarnah have produced many similar jars, often with a pink slip over which were painted horizontal bands of blue lotus petals with details in red and black.<sup>106</sup> The Megiddo specimens show no traces of decoration; but this is hardly conclusive evidence as to their original state, since the vessels found in Egypt were colored with paint of a consistency which would quickly disappear under the climatic conditions of Palestine. Jars such as are represented by Plates 17:12, 18:3, and 57:11 are usual for the period, while Plates 58:5 and 59:18 show jars thus far unique at Megiddo.

Thoroughly typical of the LB II period is a juglet with pinched lip (e.g. Pl. 16:22 and 25–28). Likewise characteristic is a shaved juglet (e.g. Pls. 16:23 and 59:15), often with handle thrust through the body. Some examples of this type were obviously handmade and were shaved when still moist. Larger jugs also bear distinguishing features (especially Pls. 16:20–21, 17:1–5, 19:18–19, 57:7, and 66:1–4).

The so-called “cup and saucer” (e.g. Pl. 19:16) seems to have been introduced into Palestine during the LB II period, but what its use was is uncertain (see p. 5). Generally the saucer has a rounded base, but one specimen with a flat base has been found (Pl. 35:24). The form of all, however, is in general the same; variations in rim (see Pls. 54:13, 58:14 and 17–18, and 59:16) seem to indicate nothing more than whims of the potter. Such a vessel found at Beisan<sup>107</sup> has a hole at the base of the cup, thus providing a passage between cup and saucer. Specimens are known also with handles and pinched lip on the saucer.<sup>108</sup>

Vessels which have here been called “funnels” but which may have served other purposes are infrequently seen in LB II tomb groups. One such piece (Pl. 54:12) seems more definitely than others to have been used as a funnel.

LB II flasks are usually of the pilgrim type (e.g. Pl. 14:5), decorated with spirals and concentric circles. The body was made in two parts which were then worked together. The neck was modeled separately and attached to the body, sometimes being strengthened by the addition of clay outside. A hole was then punched through the neck to the body, and with the placing of the handles the vessel was ready for decoration. Variations in the use of concentric circles and spirals as ornament may be seen on Plate 34 (Nos. 13–16). The LB II pilgrim flask is the prototype of EI and MI examples (see p. 159). A type of decoration unusual on flasks is seen on Plate 30 (No. 5). The position of the handle makes it extremely probable that this vessel was copied from Cypriote flasks of the base-ring class (cf. Pl. 43:13).

<sup>103</sup> See *Beth-Pelet II*, Pl. XLIX 962; Petrie, *Gaza II*, Pl. XXXIII 43 H 6; and FitzGerald, *Beth-Shan Pottery*, Pl. XLII 30.

<sup>104</sup> Schaeffer in *Syria XIII*, Pl. III 3.

<sup>105</sup> P. L. O. Guy in T. Eric Peet and C. Leonard Woolley, *The City of Akhenaten I* (London, 1923) Pl. LII xliii and p. 139.

<sup>106</sup> *Ibid.* Pl. L xxv and p. 138.

<sup>107</sup> FitzGerald, *op. cit.* Pl. XLVII 17.

<sup>108</sup> Sellin and Watzinger, *Jericho*, Pl. 37 A, 63.

The usual LB II lamp has a rounded base and turned-back rim (e.g. Pls. 20:6 and 66:21). Infrequently lamps have a flat base (e.g. Pl. 35:29).

A survey of the plates containing locally made LB II pottery impresses one immediately with the great number of vessels which bear painted decoration. Most of them were painted in one color in contrast to the two-color application of the previous period.<sup>109</sup> But the survival of decorative motifs from the LB I period (see pp. 152 f.) argues for a certain cultural continuity. Such survivals include the following patterns:

- Hourglass (see Pl. 134)
- Lattice (Pls. 14:1 and 32:22-23)
- Checkerboard (see Pl. 134)
- Triangle (Pl. 34:7)
- Irregular stroke pattern on small jugs (Pl. 63:9-13; see Pl. 41:2-10 for related LB I patterns)
- Zigzag lines between straight lines (Pls. 12:21, 32:6, and 34:9)
- Antithetic arrangement of tree and animals (see Pl. 134).

Aside from the type designs noted there are seemingly endless variations on certain of the themes (see Pl. 66:8-9 and 11-13). Unusual lattice designs for example are seen on Plates 19:8, 30:11, and 62:17. Thus, while comparable details are present on LB I and LB II vessels, comparison only serves to accentuate the great difference between them. The artistic attack and composition inherent in LB II designs give them an individuality which, aside from the telltale use of only one color, differentiates them from earlier products. In addition, the forms of the vessels on which they occur are clearly new and unrelated to earlier forms, while the arrangement of patterns in metope style reaches a fuller development in the LB II period (e.g. Pls. 13:24, 19:21, 32:22-23, and 34:8).

Only one LB II example of the tree of life with attendants has been found in the recent excavations at Megiddo (see Pl. 134), although Schumacher recovered one thirty years ago.<sup>110</sup> Others are known from Tell Ta'annak,<sup>111</sup> Tell Fara,<sup>112</sup> Gezer,<sup>113</sup> the Shephelah,<sup>114</sup> and Tell ed-Duweir.<sup>115</sup> The tree in our Megiddo specimen (Pl. 134) is quite clearly a date palm, if we judge by the spiked branches and pendants. The essence of the composition is ritual, with some of the graceful and elaborate animals and birds feeding from the fruitful branches.<sup>116</sup> The crab under the handle may have stood in some relationship to the ritual scene. A technique begun in LB II is seen in the solidly painted animals and birds, but this is only one of the forms of expression of the period known from other sites. At times animals, birds, and fish were merely outlined, or their bodies were covered with hastily done latticework. A pair of heraldic animals treated with latticework appears on the sherd found by Schumacher. The tree on this piece seems to be of assistance in the interpretation of a group of cursory designs metopically arranged on certain jugs and crater-shaped bowls. Being definitely a tree with recognizable attributes, it clearly identifies the motive on one jug (Pl. 19:21). In common there is a straight trunk with waving branches on either side, above which are fruit and branches. This design is comparable with other metopic arrangements which may have degenerated from it. Pat-

<sup>109</sup> For an instance of LB II two-color application see Pl. 59:8. The vessel represented is unusual in both shape and decoration.

<sup>110</sup> See Schumacher, *Tell el-Mutesellim* I, Fig. 54, reproduced in *OIP* XXVI, Pl. XL C.

<sup>111</sup> Benzinger, *Hebräische Archäologie* (3. Aufl.; Leipzig, 1927) Fig. 323.

<sup>112</sup> *Beth-Pelet* II, Pls. LVIII 972 and LXXXIV 972.

<sup>113</sup> Macalister, *Gezer* III, Pl. CLXV 1-2.

<sup>114</sup> Bliss and Macalister, *Excavations in Palestine*, Pl. 41, No. 13.

<sup>115</sup> Starkey in *PEFQS*, 1934, Pl. IX.

<sup>116</sup> See *OIP* XXVI 36f. for discussion of the tree-of-life pattern in LB II Palestine.

terns seen on Plates 31:4, 32:22, 16:19, 32:23, and 13:24, in the order named, represent what is conceivably a continuous deterioration from the easily recognized tree found by Schumacher.<sup>117</sup> It is of interest to note that the elaborate composition on Plate 134 and the linear motives just cited are contemporary and probably date from the time of Ramses II. Two artistic schools are manifestly represented. Another design possibly intended for a conventionalized tree is seen on Plate 35:30.

Various pottery forms illustrate the important influence brought to bear upon the eastern Mediterranean littoral by the Mycenaean world during the LB II period. Of these the most common at Megiddo is the imported stirrup cup, invariably made of finely levigated clay. The finest examples are illustrated on Plate 62 (Nos. 20–21). Others, not so well finished and slightly different in form, appear on Plates 14 (No. 7) and 34 (No. 22). One unusually large specimen was recovered (Pl. 34:21). The body ornament on such vessels normally consists of groups of broad and narrow horizontal bands;<sup>118</sup> at times a spiral was painted on top of the false neck (e.g. Pl. 34:22). Other imported Mycenaean products include a jar fragment (Pl. 32:7) and a flask (Pl. 56:9).<sup>119</sup>

Some vessels found at Megiddo, though made locally, appear to have had Mycenaean prototypes. Such are a bowl (Pl. 64:28; see also p. 113) and squat jars usually decorated with horizontal bands between which straight and curved lines were often applied vertically (e.g. Pls. 12:22, 14:5, and 34:23).<sup>120</sup> Sometimes they bear no decoration (e.g. Pl. 35:21). This type of jar continued, with variations, well into the Iron Age,<sup>121</sup> becoming finally a thoroughly local product. Imported LB II specimens have been found at other sites in Palestine.<sup>122</sup>

Crater-shaped bowls (e.g. Pl. 13:24), with one possible exception (Pl. 124:8), were made in Palestine and bear locally conceived designs; but there can be little doubt that the conception of the form was due to influence emanating from the Mycenaean culture area,<sup>123</sup> probably during the time of Ramses II, as suggested by associated scarabs. Many of the Megiddo specimens have horizontal loop handles (e.g. Pls. 13:24, 31:4, 34:7, and 35:30), as is the rule with those from Greece;<sup>124</sup> and the metopic style of decoration on our Palestinian bowls may well reflect a practice of the Aegean area,<sup>125</sup> although the beginnings of such a style at Megiddo were noted in LB I deposits (see p. 152). We have regarded one of the Megiddo crater bowls (Pl. 124:8) as a possible import because it differs somewhat in ware and paint from the others. Thus it is of considerable interest to find close decorative parallels for it at Mycenae itself.<sup>126</sup>

Phythian-Adams used the same type of Mycenaean (Late Helladic III) crater to prove that the EI culture of Philistia was derived from the Peloponnesus.<sup>127</sup> We agree with his conclusions, for the relationship is manifest, and would differ with him only in claiming an earlier

<sup>117</sup> For discussion of this point see *OIP* XXVI 37.

<sup>118</sup> Note the same characteristics on stirrup cups in A. J. B. Wace, *Chamber Tombs at Mycenae* (*Archaeologia* LXXXII [1932]) Pl. XLV 4 etc.

<sup>119</sup> Cf. A. Furtwaengler and G. Loeschke, *Mykenische Vasen* (Berlin, 1886) Pl. XX 145 and 149.

<sup>120</sup> Cf. e.g. Furtwaengler and Loeschke, *op. cit.* Pls. IX 55, XI 67, XV 95, and XVI 107. Our Pl. 35:21 appears to be closest in form to the Mycenaean specimens.

<sup>121</sup> See Albright, *AASOR* XII 72 and Pl. 51, Nos. 4–5; cf. also *OIP* XLII, Pls. 9, Nos. 35–36, and 19, Nos. 95–100.

<sup>122</sup> E.g. at Tell Abu Hawam; see Hamilton in *QDAP* IV 46, No. 283.

<sup>123</sup> Cf. Carl W. Blegen, *Korakou* (Boston and New York, 1921) Figs. 83–86 and 103; Furtwaengler and Loeschke, *op. cit.* Pls. I 4–5, XXVIII 237 and 241–42, and XXXIII 318 and 328.

<sup>124</sup> Furtwaengler and Loeschke, *loc. cit.*

<sup>125</sup> Cf. *ibid.* Pls. XXXIII–XXXV and Blegen, *op. cit.* p. 61.

<sup>126</sup> Cf. Furtwaengler and Loeschke, *op. cit.* Pls. XXXIII 317 and XXXIV 340, and Wace in *Cambridge Ancient History*, Vol. of Pls. I (1927) p. 179 [d].

<sup>127</sup> British School of Archaeology in Egypt, *Bulletin* No. 3 (1923) pp. 20–27. See now W. A. Heurtley, "The Relationship between 'Philistine' and Mycenaean Pottery" (*QDAP* V [1935/36] 90–110).

arrival of the crater type of vessel in Palestine, since all indications point to its appearance during LB II.

If the earlier appearance of locally made Mycenaean crater and other pottery types is granted, we then have to ask how they arose. The first suggested and at the same time the simplest answer is that they were copied by Palestinians from known Mycenaean forms. On the other hand, it is possible that foreigners strongly affected by Mycenaean culture were at least partially responsible for their manufacture and use. Phythian-Adams with historical records to support him considered that "Philistine" wares were made by Philistines in Palestine. We have much the same sort of archeological evidence with our earlier instances of Mycenaean copying, but we lack specific documents to tell us that foreigners were in the country during the time of Ramses II. However, the general trend of the times indicates that far-reaching movements of Aegean peoples may have occurred at any time after the fall of Knossus. Some of the allies of the Hittites at Kadesh have been interpreted as neighbors of the Hittites in Asia Minor<sup>128</sup> and also as Aegean peoples.<sup>129</sup> Certain of these and others who appear to have been related were associated in later advances on Egypt in the time of Merneptah and Ramses III,<sup>130</sup> when the "Sea Peoples" are definitely implicated. Much of the picture of the years between 1400 and 1200 B.C. must be concerned with the increasing importance of northern peoples in southern Asia Minor, Syria, and Palestine. Excavations in Syria and Palestine show clearly that Mycenaean imports were a large factor in the maritime trade, and it is probable that a considerable amount of immigration resulted. In that day the Mediterranean countries were as cosmopolitan within their limits as they are today.

Wares from Cyprus constitute by far the majority of LB II imports at Megiddo. Some of them—base-ring and white slip wares<sup>131</sup>—have already been noted in LB I deposits (see p. 154), but that they were much more characteristic of the LB II period is apparent not only from their numbers but from the extent to which they were imitated. Examination of the clay texture will generally indicate whether a vessel was imported or locally made.

Imported base-ring milk bowls are to be seen on Plates 56:3 and 35:25. White slip milk bowls are normally decorated with the familiar ladder pattern and brush dots (e.g. Pls. 19:15 and 64:29), but some were simply brush-stroked horizontally at the rim and radially on the body (e.g. Pls. 30:3 and 62:29). Imported base-ring bilbils, often painted with sweeping strokes on neck and body (e.g. Pl. 56:7-8), and locally made specimens (e.g. Pl. 67:4 and 6) have been found at Megiddo.

Vessels of Cypriote *bucchero* ware<sup>132</sup> have come from LB II burials at Megiddo, one being a jug with ribbed body (Pl. 14:21). Others (Pls. 16:17, 19:25, and 63:17) are decorated somewhat after the style of Cypriote painted bilbils (cf. Pl. 55:2). One Megiddo piece (Pl. 19:24) seems to have been made in imitation.

The view we adopted with regard to imitated Mycenaean pottery types may equally well be applied to Cypriote forms that were copied. We would not insist that all copies of Cypriote vessels were made by expatriates of the island but would consider it possible that some of them were. There is, after all, no reason to exclude Cyprus when considering the 13th century movements of Mediterranean peoples.

<sup>128</sup> Breasted, *Ancient Records of Egypt* (Chicago, 1906-7) III 136, note c, and *A History of Egypt* (2d ed.; New York, 1924) p. 424; W. Max Müller, *Asien und Europa nach altägyptischen Denkmälern* (Leipzig, 1893) pp. 354-56.

<sup>129</sup> Eduard Meyer, *Geschichte des Altertums* II 1 (2. Aufl.; Stuttgart und Berlin, 1928) p. 556; J. A. Wilson in *AJSL* LI 75.

<sup>130</sup> Breasted, *Ancient Records* III, §§ 574 ff.; IV, §§ 64 and 129; W. F. Edgerton and J. A. Wilson, *Historical Records of Ramses III* (SAOC No. 12 [1936]) pp. 35-58.

<sup>131</sup> Gjerstad, *Studies*, pp. 185-200.

<sup>132</sup> *Ibid.* pp. 193 f.

## EARLY IRON I (EI I)

There was a less decided ceramic break between LB II and EI I than between LB I and LB II, for it is evident that many EI I pottery forms were derived from LB II prototypes. Type deposits for this period came from T. 1101-2 Upper (Pls. 8-9) and T. 39 (Pls. 68-69). Plates 70-73 also contain characteristic pottery.

As already stated, one of the principal features of EI I pottery is its dependence on LB II forms. The fact that many decorative motives were clearly derived from LB II patterns adds to the picture of continuous cultural development in a Canaanite sphere in the Plain of Esdraelon. True Philistine ware appears for the first time in the EI I period in the form of two small bowls with horizontal loop handles (Pl. 8:22 and No. x 119 opp. Pl. 37), one of the bowls being painted with spirals on the body. But it is still too early to assess the extent of the influence of Philistia on the cities of northern Palestine.

Among normal products of the EI I period are simple bowls with flat bases (e.g. Pls. 8:19-21 and 69:7-8). A bowl with thumb handle (Pl. 68:4) is definitely related to LB II forms (cf. Pls. 32:21 and 34:6). A representative selection of larger unpainted bowls may be seen on Plates 70-71. Those without handles on Plate 71 carry on as a type into later periods. No. 5 on Plate 69, a large bowl with unusual handles, is the only one of its kind that was found. Quadruple- and multiple-handled bowls (e.g. Pls. 8:9, 9:3, 68:16, and 70:13-14), often painted, are characteristic. There appear to be ramifications of the crater type of bowl seen in LB II deposits (see p. 157), but it is notable that only one from the EI I burials, a Philistine piece (Pl. 8:22), has horizontal loop handles. The crater form itself is well preserved in some cases (e.g. Pls. 9:2 and 68:7 and 15).

Jugs similar to No. 18 on Plate 68 show a relationship to LB II forms (cf. Pl. 16:25-28), and the same is true for the type represented by Plates 8:13 and 72:12 (cf. Pl. 33:5). A new jug form appears on Plate 68 (No. 6). Another type, with a long troughlike spout attached to the side of the body and the handle placed 90 degrees around from the spout (see Pls. 8:12 and 68:8), was fairly common in EI I times in Palestine and continued into the following periods. A jug (which may be LB II) with similar spout but different body form is illustrated on Plate 66 (No. 14).

Though other jar types may appear in the excavation of town deposits on the tell, the relationships of those found in the tombs are well defined. Large jars (e.g. Pls. 69:1 and 3 and 73:7) are noticeably developed from LB II types (cf. Pl. 13:12 and 14), while others (e.g. Pl. 72:1 and 13) reveal a form and horizontal banded decoration likewise reminiscent of an earlier type (cf. Pl. 18:1). Locally made squat jars, first seen in the preceding period (see p. 157), appear again both decorated (e.g. Pl. 69:2) and undecorated (e.g. Pl. 71:19). The latter illustrates a style more characteristic of succeeding periods.

Chalices show a marked development in both rim and stem form (see Pls. 8:3 and 14, 68:19-20, 71:17, and 73:5), the most pronounced feature being a rounded ridge on the stem (e.g. Pl. 68:20), which, however, is not present in all specimens.

Lamps are well illustrated by No. 18 on Plate 71, which is similar to LB II specimens (cf. Pl. 32:9-11).

No "cup and saucer" vessels were found in the EI I tombs, but inasmuch as they are known both earlier and later we may presume that their absence was purely accidental.

Pilgrim flasks occur made in the same way as LB II specimens (see p. 155). They are decorated with spirals (e.g. Pls. 8:17 and 73:8), concentric circles (e.g. Pls. 68:9 and 73:9), or combinations of the two (e.g. Pls. 68:2 and 72:3-4). An undecorated specimen is seen on Plate 8 (No. 16). Pilgrim flasks continued into the later Iron Age. A new type of flask, like

the pilgrim variety in body but with a cupped mouth and vertically pierced lug handles (e.g. Pl. 68:10), makes its appearance in the EI I period and is known later.

Most decorative motifs seen in the EI I figured pottery can be traced back individually to the LB II period and in some cases beyond it to LB I and MB II. Locally executed patterns which have been noted in earlier deposits also are:

- Horizontal bands (Pls. 69:2 and 72:1)
- Herringbone (Pls. 64:36 and 68:7)
- Hourglass (Pl. 68:15)
- Lattice (Pls. 9:2 and 70:12)
- Triangle (Pl. 64:35)
- Zigzag lines between straight lines (Pls. 8:11, 9:3, and 68:16)
- Tree (Pl. 9:2)
- Spiral and concentric circles (Pls. 8:17 and 68:2 and 9).

An unusual design using lozenges and triangles and done in two colors is seen on one of the new jug types (Pl. 8:12). Other unusual designs appear on Plates 8:5 (also done in two colors) and 68:8. A pattern embodying radial strokes between concentric circles on a flask (Pl. 68:10) is unique. Arrangement of motifs in metope style (e.g. Pl. 9:2) is less common in EI I than in LB II.

Practically no foreign ware has been found in the EI I tombs, although Cypriote imports might have been expected. There were no Mycenaean imports of the types seen in LB II tombs. The decorated fragments on Plate 8 (No. 1) are considered as culturally intrusive on the basis of ware and decoration, notwithstanding the appearance on one of them of the now familiar antithetic arrangement of birds and tree. The pattern is a new conception of an old tradition, and the scale-like design above the horizontal bands (cf. p. 115) may indicate Aegean influence.<sup>133</sup>

#### COPPER AND BRONZE

With the purpose of ascertaining if possible the limits of copper and bronze usage at Megiddo and the point at which they converged, analyses of chronologically fixed metal objects have been made. Table II includes analyses of all metal artifacts thus far found in MB I or earlier contexts and a selection from the much larger groups representing MB II to EI I. In obtaining samples for analysis an effort was made to avoid oxides, but since none of the numerical statements totals 100% we may presume that there were present some oxides which here are reported only as regards metal content. Other undetermined elements are carbon and sulphur. Silver, antimony, arsenic, zinc, nickel, cobalt, and manganese were not found, though sought.

Two conclusions may be drawn from the table. First, copper appears to have been the practical metal used at Megiddo from Chalcolithic through MB I times,<sup>134</sup> for in none of the specimens from those periods was there as much as 1% tin. Second, bronze<sup>135</sup> is first seen in the MB II period;<sup>136</sup> but three specimens indicate that copper had not been entirely replaced.

The introduction of bronze, along with the striking ceramic changes which took place at the

<sup>133</sup> Cf. e.g. Furtwaengler and Loescheke, *Mykenische Vasen*, Pls. XXII 161 and XXXIV 333, and Blegen, *Korakou*, Fig. 86 and Pl. IV 4.

<sup>134</sup> The inadequacy of our chronological terminology is most apparent (i.e., there is no bronze in EB and MB I), and we hope that better terms may in time be evolved (cf. pp. 7 f.). A new understanding of present terminology is called for in any event. Cf. Garstang in *AAA* XXII 146 f. for a similar point of view.

<sup>135</sup> In ancient times essentially an alloy of copper and tin. Following Lucas in *JEA* XIV (1928) 106 and *Ancient Egyptian Materials* (2d ed.) p. 174, we have regarded the presence of less than 2% tin as accidental in an ore and have therefore considered samples containing less than 2% as copper.

<sup>136</sup> Egypt seems to have gained the knowledge of bronze at about the same time; see Lucas, *Ancient Egyptian Materials* (2d ed.) p. 178.

same time (see p. 150), can be attributed only to the Hyksos. Skeletal evidence too indicates that the MB II population differed from that which had preceded (see p. 192).

The introduction of bronze was important because of its technological advantages over copper. The use of a copper and tin alloy, aside from making a clean cast possible, produces

TABLE II  
ANALYSES OF COPPER AND BRONZE OBJECTS

Period	Field Number	Provenience	Reference	Analysis					Analyst
Chalcolithic	M 2601	T. 903 Upper	Pl. 76:4	Metallic copper, no tin					W. Itayim, Government Central Laboratories, Jerusalem
EB (Stage III)	Spatula Pin	East slope stratified area	SAOC No. 10, Fig. 13 B and C	Metallic copper, no tin					W. Itayim*
EB (Stage 0-I)	M 3636 M 3634 M 3538 M 3539 M 3635 M 3639			T. 1101 B Lower	Pl. 86:1 Pl. 86:2 Pl. 86:3 Pl. 86:4 Pl. 86:5 Pl. 86:6	Metallic copper, except for small proportion of tin in M 3538			
	M 2552 M 3227 M 3226 M 3225	T. 884 A T. 1014 B T. 1014 B T. 1014 B	Pl. 101:9 Pl. 102:8 Pl. 102:9 Pl. 102:10	Metallic copper					G. W. Baker‡
MB I				Copper	Tin	Lead	Iron	Total	
	M 3427 M 2969	T. 1120 B T. 912 A 2	Opp. Pl. 102 Pl. 123:4	98.00 95.09	nil .85	nil nil	1.6 1.13	99.6 97.07	G. W. Baker M. J. Engberg, Chicago
	M 2976	T. 912 A 2	Pl. 123:6	97.45	.69	.49	.95	99.58	M. J. Engberg
MB II	M 2696 M 2818 M 2816 M 2815 M 2813 M 2817 M 2814 M 2958 M 2959 M 2957	T. 911 C T. 911 D T. 911 D T. 911 D T. 911 D T. 911 D T. 911 D T. 912 D T. 912 D T. 912 D	Pl. 120:13 Pl. 122:1 Pl. 122:2 Pl. 122:6 Pl. 122:7 Pl. 122:8 Pl. 122:9 Pl. 133:5 Pl. 133:6 Pl. 133:7	94.23 85.92 87.35 93.08 88.95 95.61 83.86 91.92 88.97 86.31	.80 9.17 10.78 5.66 7.69 1.38 8.69 1.19 9.35 10.67	1.32 2.21 .93 .75 .39 .84 3.14 3.43 .40 .40	2.18 .82 .32 .33 .51 1.29 .83 3.30 .87 .87	98.53 98.12 99.38 99.82 97.54 99.12 96.52 99.84 99.59 98.25	M. J. Engberg
LB I	M 3492 M 3493 M 3494 M 3491	T. 1100 B	Pl. 146:3 Pl. 146:4 Pl. 146:5 Pl. 146:6	87.75 86.72 84.49 87.68	7.51 9.30 10.64 9.84	.49 1.20 .41 .45	.74 .52 .57 .49	96.49 97.74 96.11 98.46	M. J. Engberg
LB II	M 2776 M 2967	T. 911 C T. 912 D	Pl. 120:14 Pl. 133:20	97.05 86.76	2.84 6.30	nil nil	tr. tr.	99.89 93.06	M. J. Engberg
EI I	782 638	T. 39	Pl. 167:5 Pl. 167:8	90.17 89.08	7.33 9.72	nil nil	tr. tr.	97.50 98.80	M. J. Engberg

\* See SAOC No. 10, p. 40, n. 1.

† See *ibid.* p. 54, n. 2.

‡ See *ibid.* p. 76, n. 17.

a harder and more useful metal at a lower melting point.<sup>137</sup> It also opens the way through use of the closed mold to the development of new forms. A perusal of MB II and LB I metal forms (see Figs. 170–74) will demonstrate that the Hyksos were skilful metallurgists and took advantage of the properties of bronze in making their more complex tools and weapons. But

<sup>137</sup> *Ibid.* pp. 174 f.

simple objects continued to be hammered out, perhaps from cast bars. Earlier copper objects appear always to have been hammered into shape.

It is most probable that the source of Palestinian bronze is to be sought outside of the country. Analytical evidence from Sumer<sup>138</sup> and Anatolia<sup>139</sup> indicates that bronze was known in those territories as early as the first half of the 3d millennium; and since the knowledge of the copper-tin alloy seems not to have reached the countries bordering the southeastern Mediterranean until early in the 2d millennium, it is reasonable to suppose that the focal center or centers lay in the direction of the earlier knowledge of the alloy.<sup>140</sup>

#### IRON

Concerning the introduction of iron to Megiddo, classification of stratified materials from the tell will undoubtedly be of greater value than the evidence now available from the tombs. Yet there are here some facts which eventually may be found to complement stratigraphic

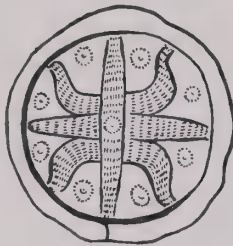

FIG. 169.—EI I GOLD MEDALLION WITH "ROYAL" OR "CAPPADOCIAN" SYMBOL (= PL. 166:8). ACTUAL SIZE

evidence: (1) One iron object, a ring (Pl. 128:19), has been attributed to the LB II period. It is not later in any event. (2) Four iron objects came from EI I burials—a dagger blade (Pl. 87:5), a ring overlaid with gold (Pl. 166:2), a fragment of a knife blade and sheath (Pl. 167:6), and a bracelet (Pl. 170:1). A Philistine bowl (Pl. 8:22; see p. 159) was found in the tomb that produced the EI I dagger blade. The Philistines have often been credited with the mass introduction of iron into Palestine, and such may prove to have been the case. But, in view of a letter written by a Hittite king to an Egyptian king (probably Ramses II) which mentions a shipment of manufactured iron to be sent to Egypt,<sup>141</sup> it need not surprise one to find LB II specimens in Palestine. The tomb of Tutankhamon contained a few iron objects,<sup>142</sup> and two of the Amarnah letters indicate that iron was slowly working its way southward in the early part of the 14th century B.C.<sup>143</sup> These two letters were sent by Tushratta, king of Mitanni, to Amenhotep III and Amenhotep IV. It is of considerable interest to note that of the several iron objects listed twelve were iron rings overlaid with gold (cf. our Pl. 166:2).

Du Buisson's excavations at el-Mishrifé (Qatna) have also yielded material relevant to the early history of iron. An inventory of the treasures of the goddess Nin-Egal, "lady of the city of Qatna," includes seven objects of iron, six of them overlaid with gold.<sup>144</sup>

Tradition has placed the earliest development of the technology of iron in Asia Minor.<sup>145</sup>

<sup>138</sup> For analyses of tin bronzes of the pre-Agade period see C. H. Desch, "Sumerian Copper," in *British Association for the Advancement of Science, Reports*, 1928, p. 438 (Ur); 1929, p. 246 (Ur); 1930, p. 267 (Ur); and 1933, pp. 304 f. (Tell Asmar and Khafajah). For analyses of other tin bronzes from Ur see H. J. Plenderleith in Woolley, *Ur Excavations II, The Royal Cemetery* (London, 1934) p. 290.

<sup>139</sup> *OIP* XXX 338 f.

<sup>140</sup> See Lucas in *JEA* XIV 108 where he suggests Persia and Armenia. The Caucasus of course is a possibility; see *SAOC* No. 4, pp. 52-57, and H. Hubert in *Syria* VI (1925) 16-29.

<sup>141</sup> H. H. Figulla and E. F. Weidner, *Keilschrifttexte aus Boghazköi I (WVDOG XXX [1916])* No. 14, lines 20-24. See also Meissner in *Deutsche morgenländische Gesellschaft, Zeitschrift* LXXII (1918) 61, and D. D. Luckenbill in *AJSL* XXXVII (1920/21) 206.

<sup>142</sup> Howard Carter, *The Tomb of Tut.ankh.Amen II* (London, 1927) xxiii and Pls. LXXXVII, LXXXII, LXXXVII; III (London, 1933) Pl. XXVII.

<sup>143</sup> See J. A. Knudtzon, *Die el-Amarna-Tafeln I* (Leipzig, 1910) No. 22 i 38 and ii 1, 3, and 16; No. 25 ii 22(?) and 28.

<sup>144</sup> Charles Virolleaud in *Syria* IX (1928) 92. The writing on the tablets is said to be comparable to that of the Amarnah tablets (*ibid.* pp. 90 f.). On the other hand Albright (*JPOS* XV 197, n. 6) believes that all of the Qatna inventories date from before the Egyptian conquest of Syria since, among other reasons, they contain no Egyptian loan words.

<sup>145</sup> Axel W. Persson believes that the true home of iron is to be sought in northeastern Asia Minor, in Armenia, and in the southern Caucasus (Kungl. humanistiska Vetenskapssamfundet i Lund, *Årsberättelse*, 1933-1934, p. 111). See also Lucas, *Ancient Egyptian Materials* (2d ed.) p. 197, and G. A. Wainwright, "The Coming of Iron" (*Antiquity* X [1936] 5-24.)

Perhaps bearing on this question was the finding at Megiddo of a gold medallion (Fig. 169) on which had been worked the "royal" or "Cappadocian" symbol.<sup>146</sup> It came from the same tomb as the EI I iron knife blade and sheath and the iron ring overlaid with gold.

## TOOLS AND WEAPONS

## SPEARHEADS

Socketed and tanged spearheads have been found, although there is only one tanged specimen (Fig. 170:2). This and one socketed spearhead (Fig. 170:1) came from EB (Stage 0-I)

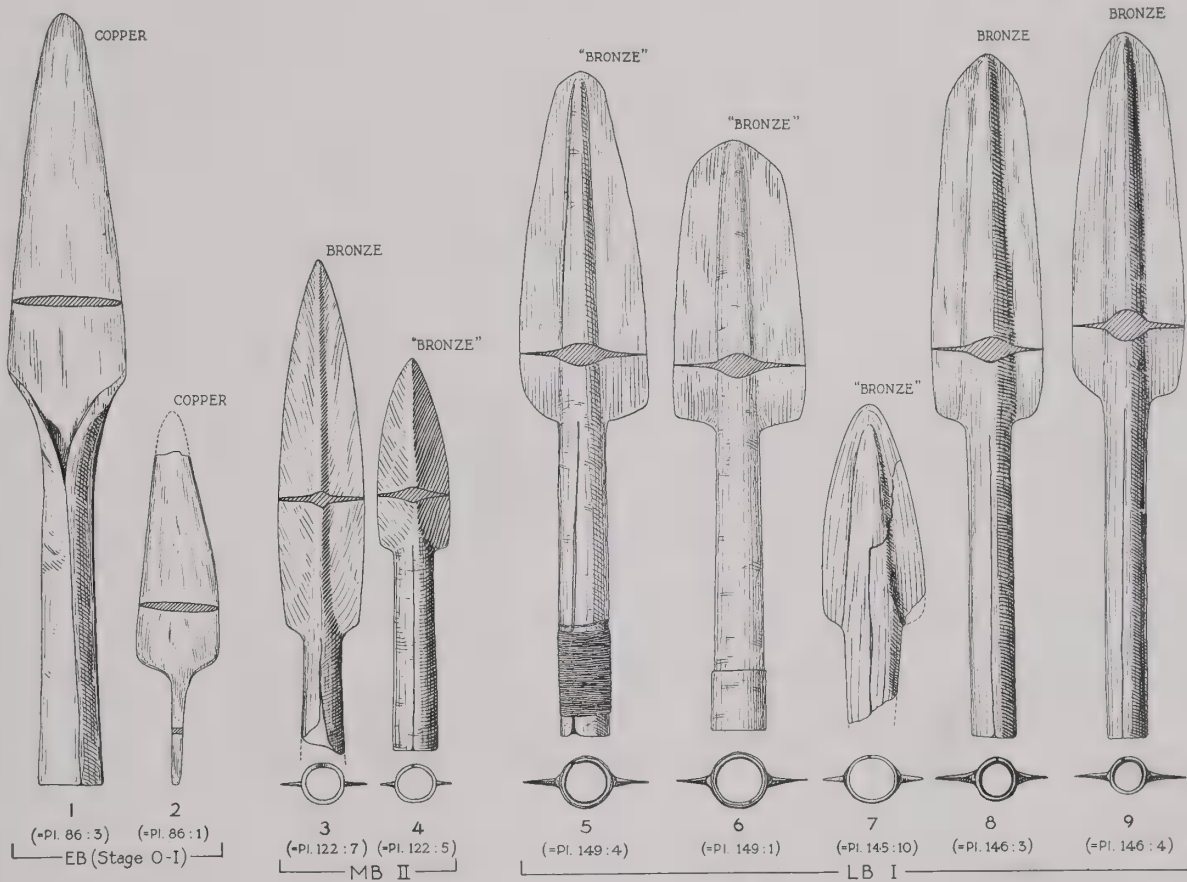

FIG. 170.—SPEARHEADS. SCALE, 1:2

context. The latter differs from the other socketed specimens (cf. Fig. 170), all of which belong to later periods.

The later type of socketed spearhead was introduced to Megiddo in the MB II period and continued into LB I. The tombs have yielded no positive evidence regarding spearheads later than LB I. Details apparent in No. 7 indicate that spearheads of this type were not cast but hammered into shape. The slit in the haft can be traced into the body of the spearhead (see Fig. 170), and the rib is often asymmetric. Due to hammering and filing, as well as to subsequent oxidation, not all details of the manufacturing process have been revealed. It is possible

<sup>146</sup> This sign, probably a thunderbolt symbol, is found frequently on stamp seals and pottery of the period of the Hittite Empires (ca. 2000–1200 B.C.) at Boghazköy, Kültepe, and Alishar. After the fall of the new Hittite Empire it disappeared in Anatolia. See *OIP* XXIX 114, 221, and Figs. 251 (No. d 1906) and 257. We are indebted to Dr. H.H. von der Osten for information on the medallion.

that head and haft were made separately, but it seems more probable that only one piece of metal was involved. A conically tapered hole, which is the extension of the hollow haft into the head, seems to indicate that haft and head were interdependent in all stages of manufacture.

Following this assumption we can explain the evidence so far adduced quite simply. A lump of metal was first beaten out and trimmed to shape, allowing for folds. Cuts were made at the junction of haft and head. A round rod with tapered end was then employed to keep the haft-hollow uniform while it was being formed. With this still in place the head was fashioned by folding and hammering, it being solid except for the tapered extension of the hollow haft.<sup>147</sup> One spearhead (Pl. 120:13), which cleaned quite satisfactorily, bears traces of rubbing and filing, particularly on the ribs and the point, and no doubt others of the same type were finished in the same manner. The socket, of course, was left open to provide for varying shaft diameters, and string and metal bands or clasps (see Nos. 5-6) served to unite more securely shaft and haft.

The same type of socketed spearhead has been found at Byblos associated with pottery some of which is comparable to Megiddo MB II forms.<sup>148</sup> It is known also from the second stratum at Ras Shamra,<sup>149</sup> which contained 12th dynasty and Hyksos remains. Inland at el-Mishrifé (Qatna) the same form was clearly present in Tomb 1,<sup>150</sup> which should probably be dated MB II and is certainly not later than LB I. Examples dated to the Middle Minoan III period and thus approximately contemporary with the Syrian and Megiddo MB II specimens have been found at Mochlos in Crete.<sup>151</sup> Inasmuch as these parallels constitute, as far as we can determine, the earliest occurrences at the various sites, the same cultural element seems to have developed contemporaneously in Syria, Palestine, and Crete.

#### DAGGERS

The earliest dagger blade (Fig. 171:1) is of copper and came from an EB (Stage 0-I) deposit. In form it differs little from an EI I specimen of iron (Fig. 171:14), which, however, has only three rivets instead of four. The only MB I dagger found (No. 2) is not directly comparable to any of the subsequent types.

MB II and LB I dagger blades tend to form groups ranging through both periods. For example Nos. 5 and 9-10 exhibit a certain affinity. Nos. 6-7, both finely ribbed and the latter delicately chased, likewise seem to follow a common tradition. Each was cast in a closed mold. Similar blades have been found in Hyksos context at Tell el-Ajul.<sup>152</sup> It should be noted, however, that finely ribbed blades seem to appear in Egypt as early as the 11th dynasty.<sup>153</sup> Cultural continuity in the two periods seems to be further demonstrated by a knob-type dagger pommel (e.g. Nos. 4 and 9). No. 4 and two limestone pommels of the same type (see opp. Pl. 133) were found in deposits which contained both MB II and LB II pottery, but they are assigned to MB II on the basis of similar specimens from a Hyksos deposit at Jericho.<sup>154</sup> This type of pommel seems to constitute a fairly reliable datum for the Hyksos period in Palestine, having been found at several sites.<sup>155</sup> Pommel No. 3 is thus far unique at Megiddo. Two LB I

<sup>147</sup> To verify this two spearheads were cut longitudinally.

<sup>148</sup> Montet, *Byblos et l'Égypte*, Pls. CXLIX 942 and CXLVII 931-32 and pp. 244-48.

<sup>149</sup> Schaeffer in *Syria* XIII, Pl. XIII 1.

<sup>150</sup> Du Buisson in *Syria* VIII (1927) Pl. XIII 4.

<sup>151</sup> Evans, *The Palace of Minos* IV (London, 1935) 842 and Fig. 821. <sup>152</sup> Petrie, *Gaza* II, Pl. XIV 71 and 74.

<sup>153</sup> Petrie, *Diospolis Parva, the Cemeteries of Abadiyeh and Hu, 1898-9* (London, 1901) Pl. XXXII 4.

<sup>154</sup> AAA XIX, Pl. XXXVII 1-2.

<sup>155</sup> See e.g. Petrie, *Gaza* II, Pl. XIV 71; III, Pl. XIX 10; IV, Pl. XLI 110-11, 115, 118; Macalister, *Gezer* III, Pl. LXI 23-24.

crescent-shaped pommels (e.g. No. 7)<sup>156</sup> were found in the same tomb. Möller considered that this type was derived from earlier forms in Egypt.<sup>157</sup> However, present evidence indicates that it did not gain its specialized crescent shape in Egypt until about the time of the 12th dynasty.<sup>158</sup> There seem to be no earlier dated specimens from the eastern Mediterranean area, but there is one from a predynastic grave at Ur.<sup>159</sup> The crescent handle seems to have been used in much later times as well, for it was depicted on reliefs at Yazilikaya,<sup>160</sup> Zenjirli,<sup>161</sup> and Babylon.<sup>162</sup> Dagger No. 8, the only example of its kind, was cast in a closed mold. There are traces of bone inlay in the handle.

Dagger blades from LB II deposits (e.g. Nos. 11–13) are markedly different from those noticed thus far. They are all tanged, two with tang bent (e.g. No. 12) presumably to keep the grip from slipping off. Similarities between dagger blades and knives of LB II date are apparent (cf. Fig. 171:1–2). A weapon with bent tang is known from Minet el-Beida.<sup>163</sup> Childe considers daggers with “the midrib prolonged into a long tang bent over at the top” as Cypriote exports,<sup>164</sup> but Syrian and Palestinian blade forms are not comparable in all details with the published Cypriote specimens.<sup>165</sup>

The only evidence yielded by the tombs for dagger forms later than LB II was one EI I blade (No. 14) made of iron. It is very simple and differs little from the earliest specimen (No. 1).

#### KNIVES

The fact that there are no knives earlier than LB II is probably due to incompleteness of the record or to wrong classification of some of the so-called daggers (see Fig. 171). Our classification is purely arbitrary and is necessarily based on forms, since little is known of the uses of blades.

The knife form which seems to be most characteristic has a rounded blade end (e.g. Fig. 172:1–2 and 5). No. 5 is the only EI I specimen of this type.

The other types (Nos. 3–4 and 6–9) are unique at Megiddo. No. 3, from a tomb which contained both MB II and LB II pottery, may represent what Petrie has called a “recurved knife,” which seems not to have appeared in Egypt until “after the Mediterranean wars of the sixth and seventh dynasty.”<sup>166</sup> No. 4 is almost exactly paralleled by a specimen from Stratum III (ca. 1100–925 B.C.) at Tell Abu Hawam,<sup>167</sup> and an undated piece from Ialysos<sup>168</sup> has a similarly notched haft end. No. 7 was cast in a closed mold. Its curled tip is like those of two knives from Troy III.<sup>169</sup>

<sup>156</sup> Reconstruction based on Petrie, *Tools and Weapons* (London, 1917) Pl. XXXIV 44 and 47. It is supposed that the grip for this (and other specimens with rivets) was made of wood or other perishable material, since no traces of it remained.

<sup>157</sup> Georg Möller, Wilhelm Schubart, and Heinrich Schäfer, *Ägyptische Goldschmiedearbeiten* (Königliche Museen zu Berlin, “Mitteilungen aus der ägyptischen Sammlung” I [1910]) pp. 22–24.

<sup>158</sup> *Ibid.* Fig. 12 (p. 22); see also Petrie, *Tools and Weapons*, Pls. XXXIII–XXXIV.

<sup>159</sup> Woolley, *Ur Excavations* II, Pls. 152 and 154 b.

<sup>160</sup> Hugo Gressmann, *Altorientalische Bilder zum Alten Testament* (Berlin und Leipzig, 1927) No. 342.

<sup>161</sup> *Ibid.* No. 340.

<sup>162</sup> *Ibid.* No. 339.

<sup>163</sup> *Syria* XIII, Pl. X 1, No. 3.

<sup>164</sup> V. Gordon Childe, *The Bronze Age* (New York and Cambridge, 1930) pp. 78 f. and Fig. 7, No. 5.

<sup>165</sup> E.g. Gjerstad *et al.*, *Cyprus* I, Pl. CXLII.

<sup>166</sup> Petrie, *Tools and Weapons*, p. 25 and Pl. XXVI 130–40.

<sup>167</sup> *QDAP* IV, Pl. XXXIII 124.

<sup>168</sup> Petrie, *op. cit.* Pl. XXIV 33.

<sup>169</sup> Henry Schliemann, *Ilios* (New York, 1881) p. 507, Nos. 965–66.

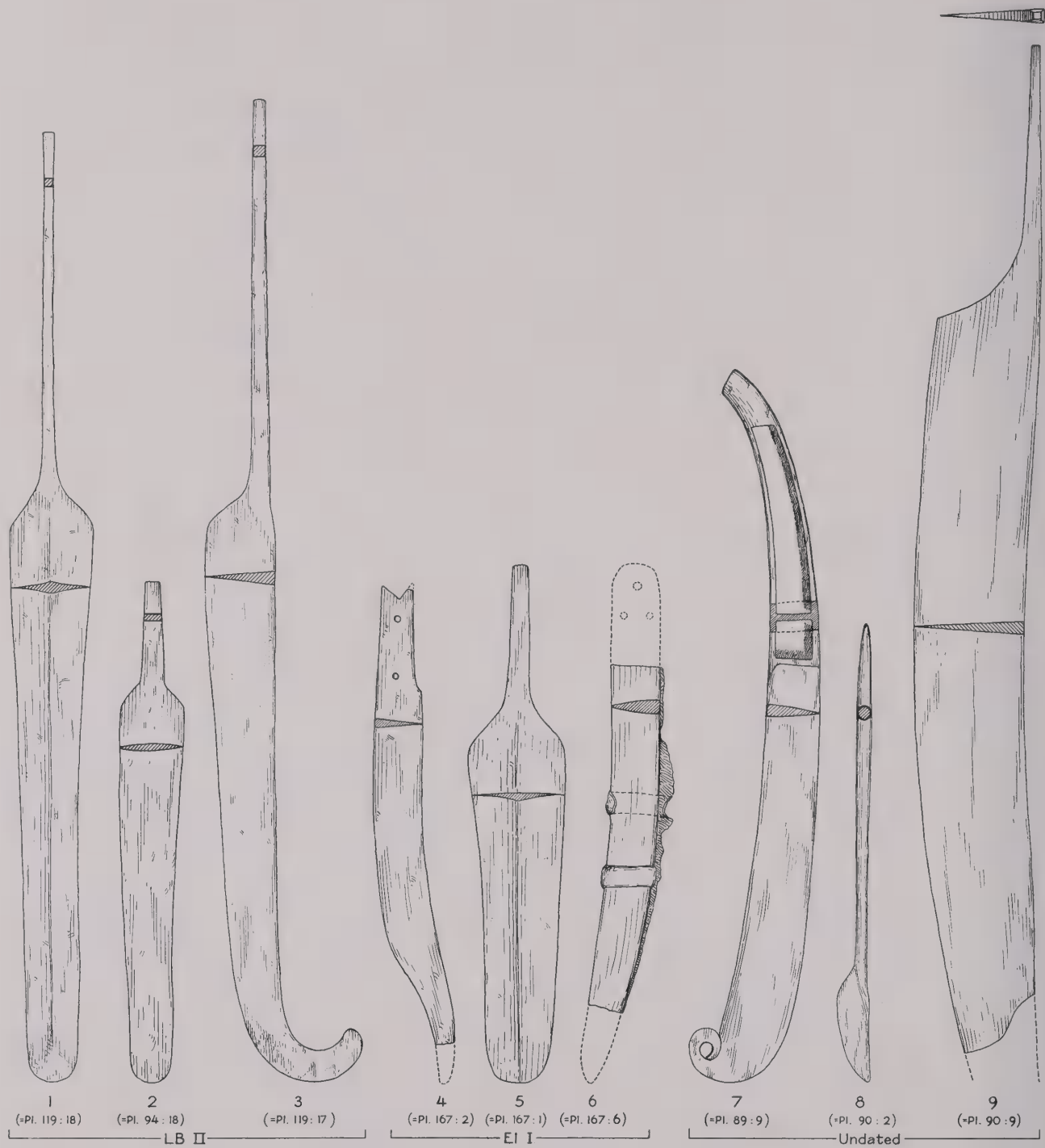

FIG. 172.—“BRONZE” AND IRON (No. 6) KNIFE BLADES. SCALE, 1:2

## AXHEADS AND OTHER BLADES

Two socketed axheads (Fig. 173: 1-2) were found in strictly MB II context. Two others of the same type (Pls. 118:3 and 133:4) came from mixed MB II and LB II context but are assigned to MB II by analogy with the two well dated specimens. As for other kinds of blades

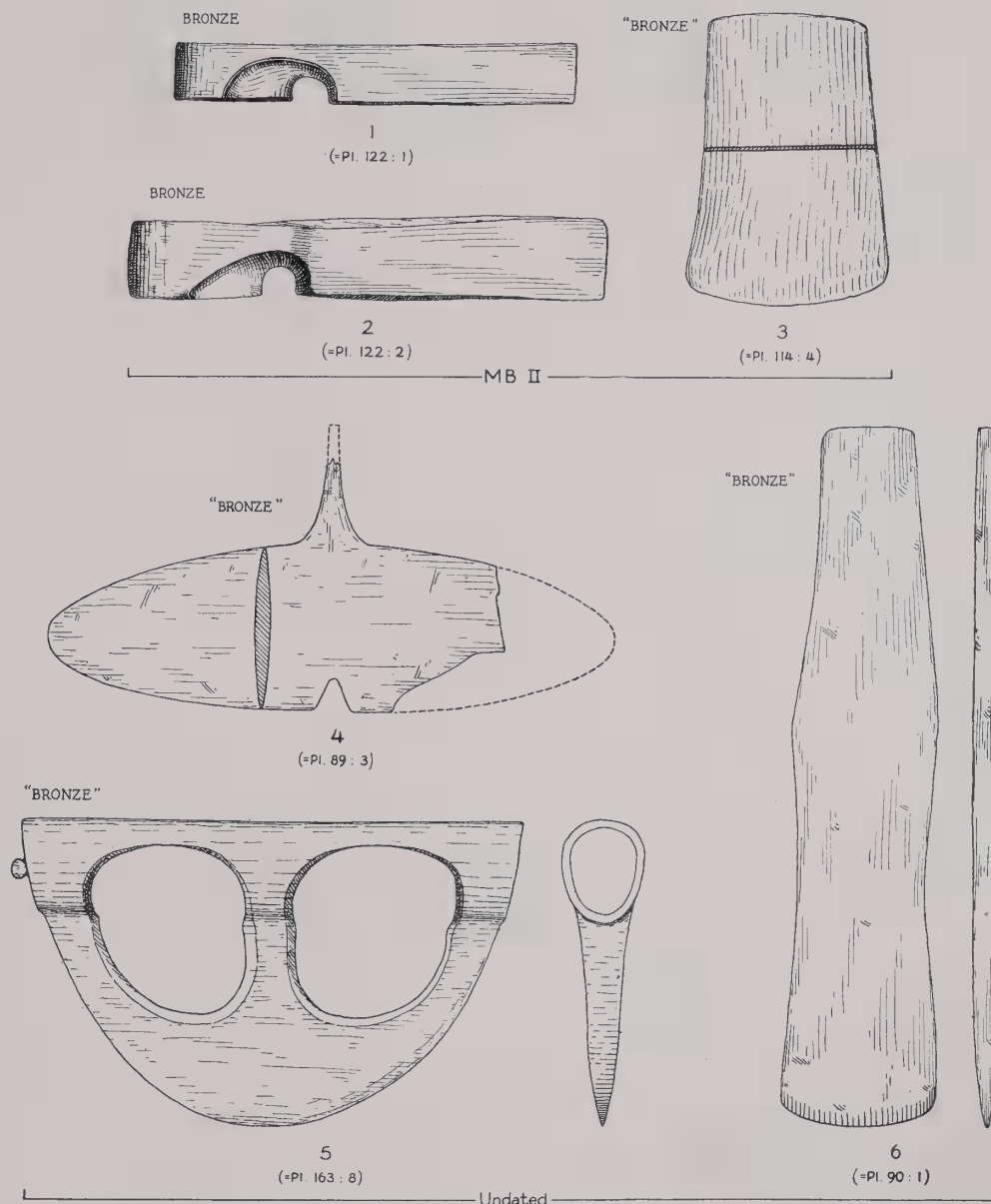

FIG. 173.—AXHEADS AND OTHER BLADES. SCALE, 1:2

(Nos. 3-6), only one of each type was found, and only No. 3 can be dated. It has MB II parallels from the tell. Nos. 1-2 and 5 were cast in closed molds.

Two axheads somewhat similar to Nos. 1-2 were found in a MB II tomb at Jericho,<sup>170</sup> and at Tell el-Ajul precisely the same form came from a Hyksos deposit.<sup>171</sup> Variations of this type have been found in many places, perhaps most often in Europe.<sup>172</sup>

<sup>170</sup> AAA XIX, Pl. XXXVII 3.

<sup>171</sup> Petrie, *Gaza II*, Pl. XIV 73.

<sup>172</sup> Note distribution in Petrie, *Tools and Weapons*, Pls. IX-XI; see also Gjerstad, *Studies*, p. 233, axes 5-6.

Blade No. 4 is paralleled by objects from other sites. At Tell Abu Hawam fragments of two specimens were found in Stratum IV (ca. 1230–1100 B.C.).<sup>173</sup> Hamilton compares them to a larger object from Egypt which has been called a halberd<sup>174</sup> but considers the Tell Abu Hawam objects too light for such a purpose. A blade almost identical with that found at Megiddo, including the notch, came from Ras Shamra.<sup>175</sup> The notch appears to have been as essential to such objects as the shape of the blade and tang, but its purpose remains uncertain.

The type of socketed axhead represented by our No. 5 appears to have come into Syria and Palestine in the early part of the 2d millennium. In Syria, at Byblos, a specimen was found in a foundation deposit of the early 2d millennium,<sup>176</sup> and some with longer blades<sup>177</sup> are of approximately the same date. At Ras Shamra one of the latter type was found in the second stratum,<sup>178</sup> which contained both 12th dynasty and Hyksos remains. Petrie<sup>179</sup> calls attention to the fact that a 12th dynasty scene<sup>180</sup> shows a "Syrian" carrying a weapon of the Megiddo type and Egyptians wielding similarly shaped axes which, however, were not socketed but were let into the handles, thereby apparently indicating that the socketed type was not characteristic of Egypt at the time. While these are the earliest examples of this particular type of socketed ax known for Syro-Egyptian territory, it seems probable that its antecedents are to be sought outside of Syria, since related types are known from earlier times in Mesopotamia.<sup>181</sup>

Adz heads like No. 6 have occurred elsewhere in Palestine. Perhaps the earliest is one found in a MB II or LB I tomb at Tell el-cAjul.<sup>182</sup> A similar object pierced at the "back end" came from the "Seti I" level at Beisan.<sup>183</sup> At Tell Abu Hawam the form was found in Stratum III.<sup>184</sup> A similar blade from el-Mishrifé (Qatna) may be LB II.<sup>185</sup> With regard to Asia Minor, Dr. Kurt Bittel informs us that adzes with more pronounced protuberances and of greater width have been found at Kültepe, Troy, Bolu, Samsun, and Gâvurkalesi. At Alishar and Boghazköy they appeared in Hittite and Phrygian strata.

#### TOGGLE PINS

Since evidence from the tell indicates that toggle pins did not occur after LB I, we have attributed certain specimens from the tombs (e.g. Pl. 107:12–14) to MB II rather than LB II—the two periods possible on the basis of pottery context. No. 4 in Figure 174, the only specimen with a twisted head, is dated MB II on the basis of Hyksos parallels at Tell Fara.<sup>186</sup> Two EI I objects classed as toggle pins (Nos. 12–13) are very different from all of the others. Because they were made from sheet metal they do not have the usual eye formed by splitting the haft.

Frankfort has called attention to the Caucasus as a possible source for some metal forms, including toggle pins, found in the Near East.<sup>187</sup> Hubert argued in practically the same vein in dealing with certain types of metal objects found at Byblos.<sup>188</sup> He cited toggle pins from the Caucasus which are closely comparable to some from Megiddo.<sup>189</sup> It should be noted, how-

<sup>173</sup> QDAP IV 32, No. 191.

<sup>176</sup> M. Dunand in *Syria* X (1929) 210 f. and Pl. XXXIX 1.

<sup>174</sup> Petrie, *op. cit.* Pl. VI 187.

<sup>177</sup> Montet, *Byblos et l'Égypte*, Pl. CXLIX 940–41.

<sup>175</sup> *ILN*, April 27, 1935, p. 690, Fig. 24.

<sup>178</sup> Schaeffer in *Syria* XIII, Pl. XIII 4.

<sup>179</sup> *Op. cit.* p. 9.

<sup>180</sup> Percy E. Newberry, *Beni Hasan I* (London, 1893) Pl. XLVII.

<sup>181</sup> Woolley, *Ur Excavations* II, Pl. 224 A 14–15; see also André Godard, "Les bronzes du Luristân" (*Ars Asiatica* XVII [Paris, 1931] 56 f.).

<sup>182</sup> Petrie, *Gaza III* (1933) Pl. XXII 93. Petrie assigns the tomb in which it was found to the 15th dynasty.

<sup>183</sup> Alan Rowe in *ILN*, Nov. 12, 1927, p. 856, Fig. 8.

<sup>184</sup> QDAP IV 26, No. 130.

<sup>187</sup> SAOC No. 4, pp. 52–55.

<sup>185</sup> *Syria* VIII, Pl. LXIX 1, No. 6.

<sup>188</sup> *Syria* VI 16–29.

<sup>186</sup> *Beth-Pelet I*, Pl. VI.

<sup>189</sup> *Ibid.* Fig. 7.

ever, that toggle pins were known in Mesopotamia as early as about 3000 B.C.<sup>190</sup> The earliest specimens from Cyprus seem to be of the Early Cypriote II period.<sup>191</sup> At Alishar one specimen

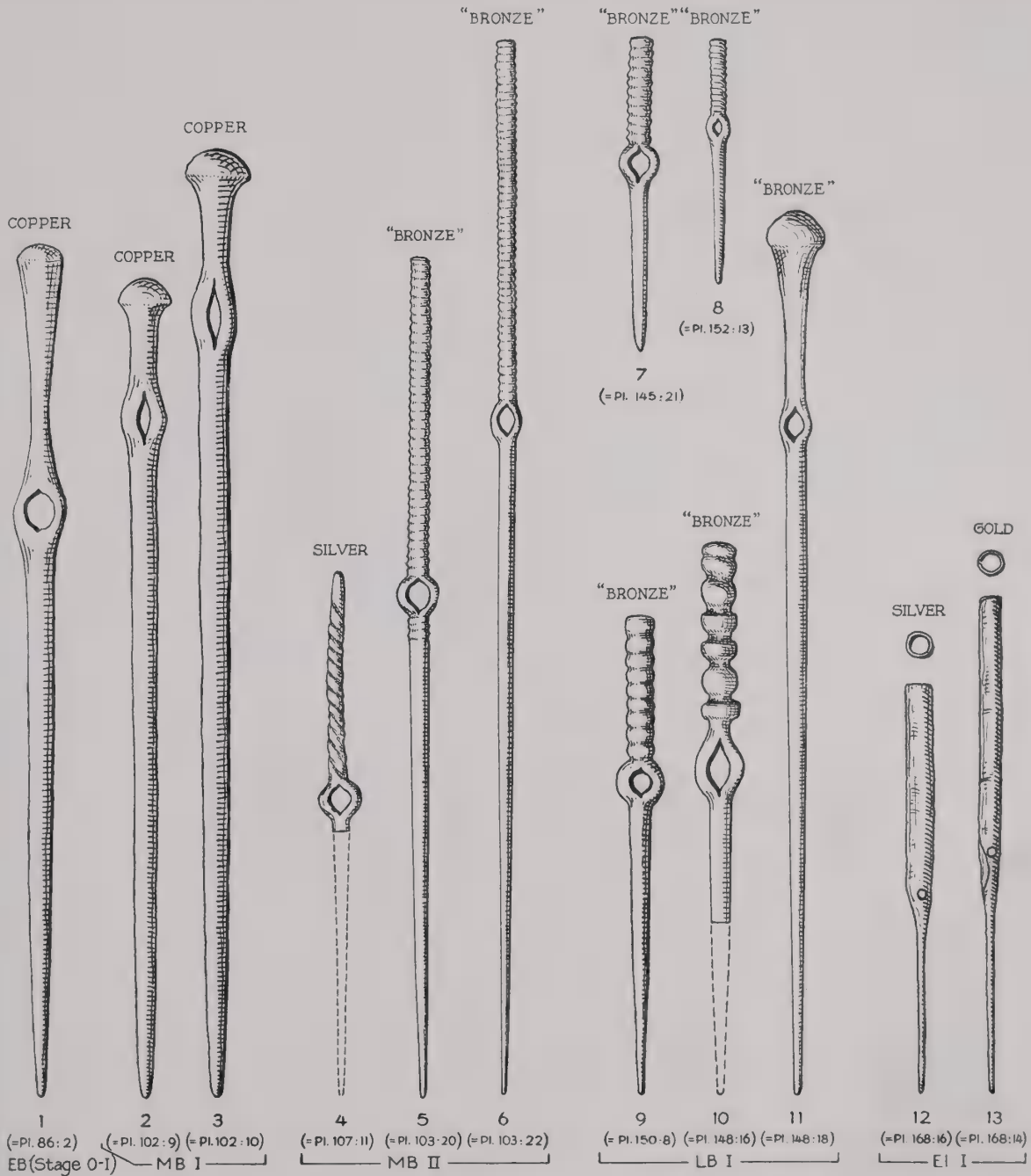

FIG. 174.—TOGGLE PINS. ACTUAL SIZE

was found in Stratum I (Copper Age),<sup>192</sup> but Dr. von der Osten tells us that it was perhaps intrusive, since none occurred in the Early Bronze Age but they were common in the period

<sup>190</sup> See Woolley, *Ur Excavations* II 239 and 310 and Pl. 231; Speiser, *Excavations at Tepe Gawra* I 109, 114, and 183.

<sup>191</sup> Gjerstad *et al.*, *Cyprus* I, Pl. XXXII 5, No. 24, and p. 127. <sup>192</sup> *OIP* XIX, Fig. 69 b 512.

of the Hittite Empires (*ca.* 2000–1200 B.C.).<sup>193</sup> They seem to have made their first appearance in Syria<sup>194</sup> and Egypt<sup>195</sup> at the time of the Hyksos. In Palestine they appeared in numbers at the same time,<sup>196</sup> but three earlier specimens were found at Megiddo (Fig. 174:1–3). Present attempts to determine sources are premature, but it seems possible at least to visualize a progressive distribution from northeast of Palestine.<sup>197</sup>

#### FLINT IMPLEMENTS

The tomb deposits have shown that flints, far from being an attribute of only the earliest periods, were of considerable importance well into historic times. In fact, the present-day use of flint implements argues for uninterrupted continuity. Specimens as late as EI (e.g. Pl. 169:1–3) have come from tomb deposits, while excavation on the tell has shown that all Iron Age strata contained flints in abundance.

#### OTHER STONE IMPLEMENTS

Simple basalt grinders (e.g. Fig. 127) were in use at Megiddo as early as Chalcolithic times (see opp. Pl. 76).<sup>198</sup> They have also been found in the latest strata on the tell<sup>199</sup> and to some extent are in use today. The form of this simple agricultural accessory may be considered universal as far as the Near East is concerned.<sup>200</sup>

Stone rubbers and hammers (see p. 7) have been found in practically the same form in the earliest deposits so far known at Megiddo<sup>201</sup> and in the latest strata on the tell.<sup>202</sup> No unusual shapes seem to have been developed, the only requirements being a stone that could be gripped and a surface that could be used for the purpose at hand.

Of the few basalt pestles found the earliest that can be dated by context are MB II or LB II (Pl. 112:13–14), but there is little reason to suppose that they were not known previously, since the pestle is a natural outgrowth of the rubber-hammer concept with a special development of the grip.

#### WHORLS AND SPINDLES

Under this heading we have classified objects of the types seen in Figure 175 without intending to limit them as to function. Whorls appear not to have been used prior to MB II, unless certain doughnut-shaped objects (see Pl. 76:5–6 and 17) were used as such. The four MB II whorls (Fig. 175:1–4) differ from all other dated specimens in both material and form. Reused potsherds such as No. 5 are known from other periods on the tell.<sup>203</sup>

An entirely new conception seems to begin in LB II, the period of most of the whorls and spindles found in the tombs. Bone is the commonest material, and the form is essentially conical. The principal ramifications are shown by Nos. 6–18, which include examples of all materials used except ivory. For ivory whorls, which are similar in form to some of the bone specimens, see Plate 95:41–42 and 47–48. The reconstruction showing whorls mounted on a spindle (No. 6) is based on a specimen found thus *in situ*. A pin passed through the whorls into holes in the spindle. Whether all so-called whorls were similarly mounted is of course not

<sup>193</sup> See e.g. *OIP* XXIX, Fig. 283.

<sup>194</sup> Schaeffer in *Syria* XIII, Pl. XIII 3 (opp. p. 20).

<sup>195</sup> Petrie, *Hyksos and Israelite Cities* (London, 1906) Pl. VI 10–14.

<sup>196</sup> See e.g. Petrie, *Gaza* II, Pl. XVIII.

<sup>197</sup> See Max Ebert, *Realexikon der Vorgeschichte* I (Berlin, 1924) Pls. 53 b 4 and 68 a 4 and 7–8 for specimens found in European Bronze Age contexts.

<sup>198</sup> In the east slope stratified deposit basalt grinders were common in Stages I–VII (see *SAOC* No. 10, p. 40).

<sup>199</sup> E.g. *OIP* XLII, Pl. 114, No. 11.

<sup>200</sup> See e.g. Breasted, *The Oriental Institute of the University of Chicago* (*OIC* No. 1 [1922]) Fig. 45, for Egyptian Old Kingdom models in use.

<sup>201</sup> See *SAOC* No. 10, p. 40. <sup>202</sup> *OIP* XLII, Pl. 106. <sup>203</sup> E.g. *OIP* XLII, Pls. 94, Nos. 45–46, and 95, Nos. 18–19.

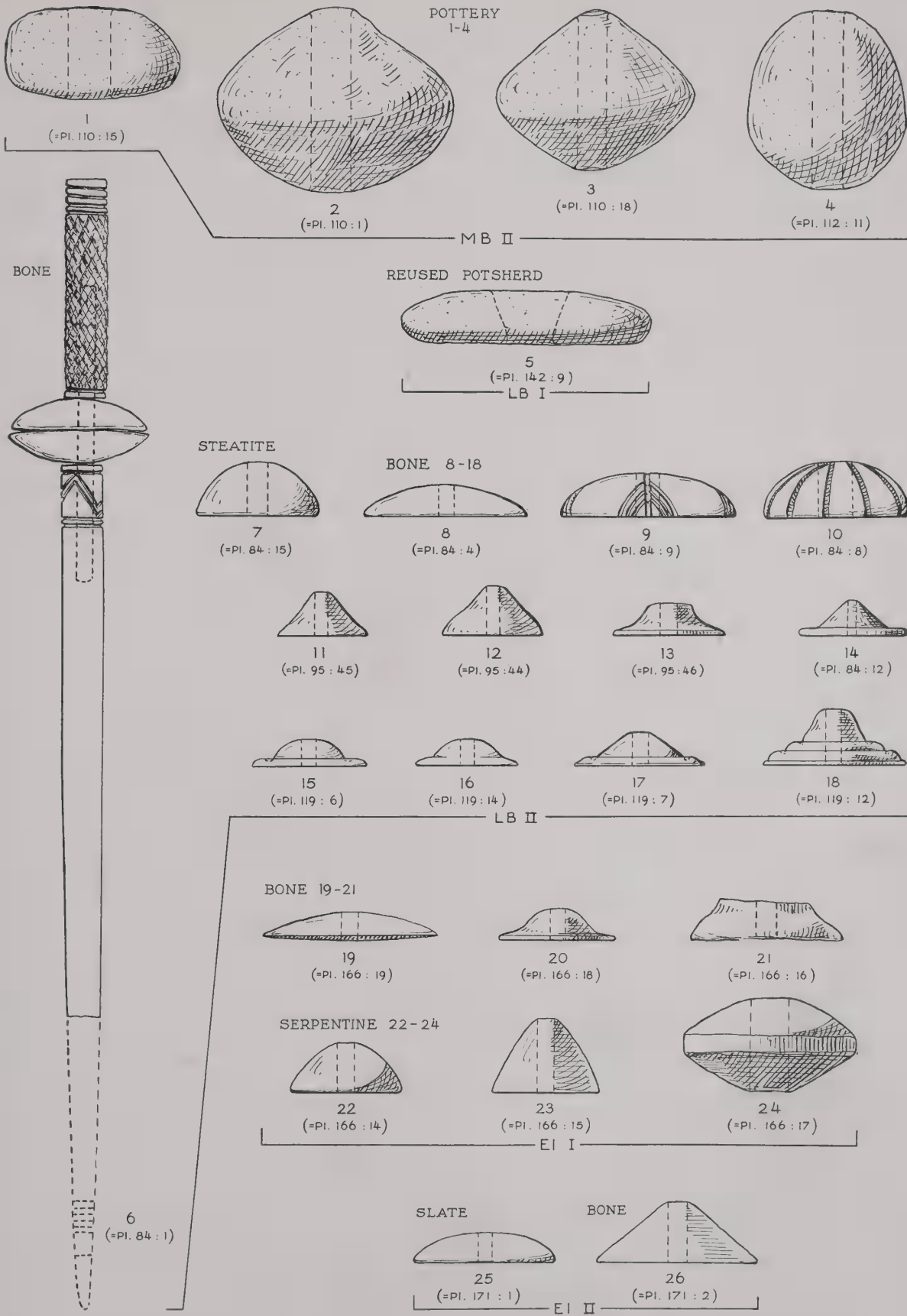

FIG. 175.—WHORLS AND A SPINDLE. ACTUAL SIZE

known. Except for a LB I fragment of worked bone which may be a spindle (Pl. 142:5), no spindles earlier than LB II have been noted.

The EI whorls (Nos. 19-26) show dependence on LB II forms for the most part. Whorls from Strata V and IV at Tell Abu Hawam<sup>204</sup> resemble a number from the roughly contemporary LB II and EI I burials at Megiddo.

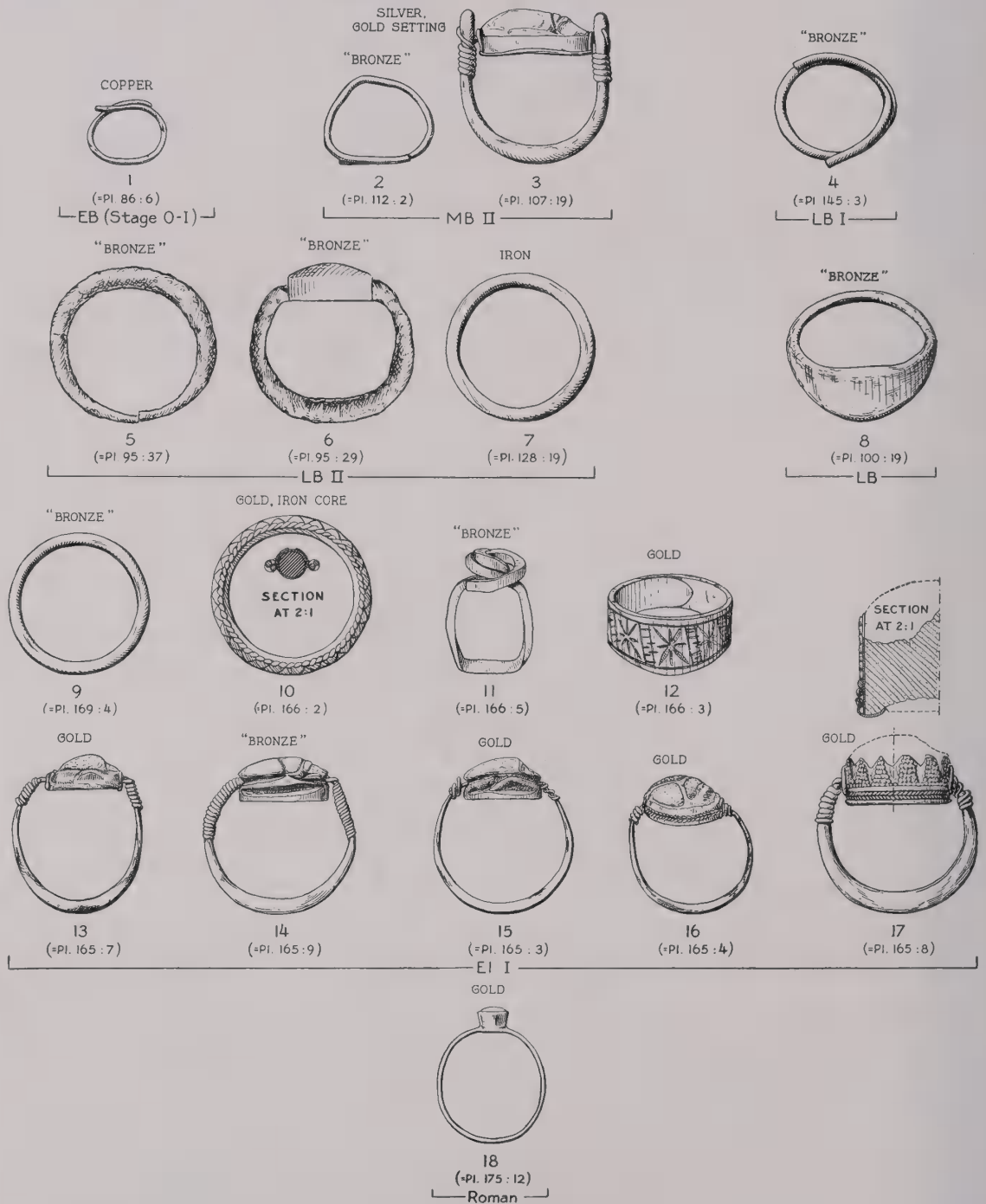

FIG. 176.—FINGER RINGS. ACTUAL SIZE

<sup>204</sup> Hamilton in *QDAP* IV, Pl. XXXVII 2.

## PERSONAL ORNAMENTS

## FINGER RINGS

The earliest evidence of the use of finger rings at Megiddo consists of a specimen in copper (Fig. 176:1) from EB (Stage 0-I). It is difficult to conceive of a simpler form of ring, for its manufacture required only that a strip of metal be beaten out and bent to fit the finger. The same process in "bronze" is seen in later specimens (Nos. 2 and 4). No. 11, made of "bronze" wire, is a more elaborate specimen, square in cross-section and with a knotted bezel. A "bronze" ring with a neatly arranged electrum knot at the narrowest part (Pl. 120:10) may be either MB II or LB II. The closed circle is first seen in LB (Nos. 7-8), though a MB II fragment (Pl. 122:4) may have been of that style. No. 7 is of iron. A pottery bezel (Pl. 93:8), the only pottery specimen found, seems to be the work of an amateur. It should not be later than LB II. The stippled decoration was done with a pointed instrument. Of the EI I rings No. 10 is a fine example of the goldsmith's art. The iron core was covered with two gold strips, one overlapping the other (see section). Then a two-strand gold rope was welded to each side. No. 12 also is a pleasing piece of goldwork. Another such ring was found in the same tomb (Pl. 166:4). Both consist of imperfectly closed strips. The decoration on No. 12 is entirely scratched, but some gouging had been done on the other. From a grave of the late Roman period came a ring (No. 18) which is different from any of the older rings. Its thin gold band and gold setting containing a piece of green glass are paralleled in modern rings.

No. 3 is assigned to MB II on the basis of parallels from Tell el-Ajul,<sup>205</sup> though both MB II and LB II pottery were found in the Megiddo tomb. It is differentiated from later examples by the manner in which the scarab is attached to the ring, silver pegs having been thrust into the scarab through holes bored in the ring.<sup>206</sup> The wire wound around the ring is purely decorative. The wire on EI I scarab rings also (e.g. Nos. 13-17) is for decorative purposes, but the ends of the ring itself are thrust into the borings of the scarab. Scarabs are not always placed in a setting (e.g. Nos. 14-15), but it was perhaps more usual. Nos. 3 and 13 illustrate a simple type of gold setting. Nos. 16-17 on the other hand are more elaborate. The exquisite workmanship includes braiding of gold wire and granulation. In No. 16 the surface features of the scarab are outlined in gold. The section of No. 17 reveals to a greater degree than does the side view the skill involved in making the setting.

The ring shown on Plate 128:15, found with MB II and LB II pottery, is of special interest because of the eight letters roughly incised on the bezel (Fig. 177), an important addition to the meager epigraphic materials found in Palestine. The following comments, together with Table III, were kindly given us by Professor W. A. Irwin and Dr. R. A. Bowman, who examined the photographs and casts of the ring.

The bezel of the ring is separated into three registers, of which the second is a "floral" pattern and the third is inscribed with angular letters. In keeping with the very angular style of the "floral" pattern, there is not a curved line in the entire legend. The carelessly made letters suggest those of the Aramaic legends found on some Assyrian seals<sup>207</sup> but are even more crudely made. Often the parts of the letters that we should expect to be joined were left disconnected. Although most of the letters resemble those of early Phoenician inscriptions, the vertical form of the  $\beth$ , like that on two 19th dynasty vessels found at Tell ed-Duweir,<sup>208</sup> the diamond-shaped  $\aleph$ , similar to that in an early Byblos inscription on stone discovered by

<sup>205</sup> Cf. Petrie, *Gaza IV* (1934) Pls. VII 264 and XVIII 124.

<sup>206</sup> Two other MB II scarab rings (Pls. 105:1 and 106:14) are too badly corroded to be described in detail.

<sup>207</sup> E.g. *Corpus inscriptionum Semiticarum II* (Paris, 1889) Nos. 75 and 77.

<sup>208</sup> Starkey in *ILN*, Aug. 10, 1935, pp. 240 (Figs. 7-8 and 11-12) and 242.

Dunand,<sup>209</sup> and the grotesque  $\aleph$ , which has its nearest parallel on an ostrakon from Ain Shems,<sup>210</sup> would seem to indicate that the letters are to be classed with those called "Old Canaanite."<sup>211</sup> In addition to the careless formation of the letters the presence of several short strokes, principally at the lower margin of the ring, makes transliteration difficult. Some of them may have been intended as word dividers, as found in inscriptions of Ahiram<sup>212</sup> and Abiba'al<sup>213</sup> from Byblos, but it is always possible that they, especially those on the very edge, may prove to be accidental scratches. That the metal is very soft can be seen from the fact that part of the lower edge of the bezel is entirely worn away. However, since the ring shows no scratching apart from a few lines which might easily be explained as parts of the more archaic letters, it is probable that the strokes in question are to be interpreted as parts of the letters near which they stand.

At first glance the legend appears to be confined to the lowest register, but faint ladder-like traces at the extreme right in the second register, almost on the band of the ring, look very much like worn remains of the letter  $\aleph$ . It seems clear in the enlarged photograph (see Fig. 177)



FIG. 177.—LB II GOLD RING WITH OLD CANAANITE CHARACTERS (= PL. 128:15). SCALE, 2:1

but, perhaps due to faulty impression, is so faint as to be almost invisible in the cast. Since these lines do not resemble the characteristic "floral" motif of the second register it is possible that they represent a letter. If this be the case the reading of the legend is aided, for it begins otherwise with a meaningless single letter followed by what is probably a word divider. Just why the first letter should be in the line above the rest of the legend is uncertain. If the legend read from left to right it could easily be explained by the hypothesis of crowding at the end, but it is unlikely that the legend, if Semitic, is to be read in that direction.

In the lowest register the first letter, apparently isolated from the others by a word divider, is very difficult to identify. There are too many strokes for one letter. The acute angle formed by the two main strokes most resembles  $\aleph$  as found in the Ahiram inscription (see Table III). If the tiny line attached to the left of the horizontal stroke is intentional the letter may be an angular  $\aleph$ . It is less probable that the line regarded as a word divider is really part of the letter

<sup>209</sup> See Albright in *BASOR* No. 63 (Oct. 1936) pp. 10 f. and Fig. 2, where he suggests a date of "about 1400 B.C." on "epigraphic grounds alone."

<sup>210</sup> Elihu Grant, *Ain Shems Excavations (Palestine) 1928-1929-1930-1931 I* (Haverford, Pa., 1931) Pl. X. Cf. Hubert Grimme in *Archiv für Orientforschung* X (1935-36) 269-77.

<sup>211</sup> Grimme, *op. cit.* pp. 267-81.

<sup>212</sup> R. Dussaud in *Syria* V 135-45. Dussaud dates this inscription about 1250 B.C., while Albright (*op. cit.* p. 8) would regard the date as 1100 B.C.

<sup>213</sup> Dussaud, *op. cit.* pp. 145-47.

and makes it a delta-shaped  $\nabla$ . This single letter is difficult to interpret, but if the marks at the right in the middle register represent  $\nabla$  there is a possibility of discovering some meaningful word. The deeply incised line in the second register which seems to join the strokes of the first letter in the register below to form  $\nabla$  is not part of the letter but belongs to the "floral" decoration.

The second letter, after the word divider, is almost certainly  $\nabla$ , unlike the rounded type on the Tell ed-Duweir bowl and the 'Ain Shems ostracon but angular like those in the Ahiram inscription. The next three strokes form an angular  $\nabla$ .

The fourth letter is the same as that identified as  $\nabla$  on the Tell ed-Duweir ewer and bowl, that on the latter being reversed. Although the inscriptions on the Tell ed-Duweir vessels apparently must be read in opposite directions, that fact must not weigh heavily against the

TABLE III

ALPHABETIC SIGNS ON A RING FROM MEGIDDO AND RELATED SINAITIC, OLD CANAANITE, AND PHOENICIAN CHARACTERS

	SINAITIC	'AIN SHEMS	BYBLOS	TELL ED-DUWEIR BOWL	TELL ED-DUWEIR EWER	MEGIDDO	AHIRAM
א							
ב							
ג							
ד							
ה							
ו							
ז							
ח							
ט							
	ca. 1800 B.C.	ca. 1500 B.C.	ca. 1400 B.C.	ca. 1350-1250 B.C.		ca. 1350-1250 B.C.	ca. 1250 B.C.

identification of the letters, for the use of retrograde characters in this early period is attested by an  $\nabla$  and a  $\nabla$  on the Byblos stone, a  $\nabla$  and a  $\nabla$  on the 'Ain Shems ostracon, and a  $\nabla$  and a  $\nabla$  on the Tell ed-Duweir ewer. Writers then were not as particular about the direction in which the letters faced as they were in later periods. It is improbable that the letter under discussion once had another stroke below to make it resemble the  $\nabla$  of the Ahiram inscription.

The  $\nabla$  is followed by an X-shaped  $\nabla$  such as is found occasionally as early as the Sinaitic inscriptions.<sup>214</sup> The  $\nabla$  of the early inscriptions is usually vertical with the crossbar almost at right angles to the vertical line, but the X-shaped form is found side by side with the other in the Ahiram inscription. The deep scratch below the  $\nabla$  may be an accidental mark or a word divider inserted after the writing of the line was completed. The placement of the letter low in the register and the length of the upper part of the cross make it improbable that the letter represents an attempt to form  $\nabla$  with straight lines.

<sup>214</sup> See J. Leibovitch, *Les inscriptions protosinaitiques* ("Mémoires présentés à l'Institut d'Égypte" XXIV [Le Caire, 1934] Fig. 24, No. 346a).

The sixth letter is quite difficult to identify, but the outstanding impression is that the letter has a triangular head such as is found later with  $\beth$ ,  $\daleth$ , or  $\beth$ . If the vertical line to the right is assumed to be a scratch or a word divider, one might take the letter for  $\beth$  with a very large top and an accidental stroke below. It is most probably a disconnected and angular representation of the  $\beth$  found in a very curved form in the Sinaitic inscriptions<sup>215</sup> and also on the 'Ain Shems ostrakon.<sup>216</sup> The vertical back is the same in all cases, but, due to the straight-line technique of the decoration on the ring, the two inclosed portions are triangular rather than rounded (see Table III). An alternative would be to regard it as a different representation of the letter that follows it. In that case the vertical line to the right would have to be considered part of the triangular head. Following the  $\beth$  is a vertical stroke which looks like a word divider. There is even a little more space than usual between the  $\beth$  and the word divider, as though the writer unconsciously as well as purposely intended to indicate a break in the legend.

If this vertical stroke is to be taken as part of the letter which follows the  $\beth$ , rather than as a divider, one might consider that letter to be another  $\beth$ . But it is more probably to be identified with the diamond-shaped character found on the Byblos stone mentioned above and read as  $\beth$  by Grimme.<sup>217</sup> The last letter is indisputably  $\aleph$ .

An absolutely final transliteration, much less a translation, of this ring eludes us. Disregarding the probable word dividers, we read the letters in the lowest register from right to left as  $\aleph\aleph\aleph\aleph$ . Read in the other direction they rapidly fall into combinations unlikely for a Semitic language. What is expected in the legend is the name of the owner of the ring, introduced by the preposition  $\beth$ , "belonging to." Since Egyptian (scarabs; see Pl. 131), Hurrian (Nuzi type seal, Pl. 131:15), and Mycenaean (pottery, e.g. Pl. 34:21-22) as well as native Canaanite materials were found in association with the ring, the number of possible non-Semitic names that might occur is very great and, due to the debatable nature of such roughly made letters, the results achieved must be regarded as uncertain. The difficulty of interpretation is increased by the queer distribution of the strokes assumed to be word dividers. They isolate the first letter of the lowest register and leave a similarly impossible reading,  $\aleph\aleph$ , at the end of the line. If the stroke at the bottom of the  $\beth$  is also a divider, which seems unlikely, the sixth letter likewise stands in isolation.<sup>218</sup>

The interpretation is aided if  $\beth$  is to be read before the first letter ( $\beth$ ) in the bottom register, for then one might find in the  $\beth\aleph$  some word for "ring," related perhaps to Hebrew  $\aleph\aleph$ , "circle." The  $\beth$  is probably the preposition indicating ownership, followed by a personal name or, less likely, by a title. The ring defies translation and, like so many other brief and ambiguous legends found on seals and gems, must remain, for the time being at least, in the realm of conjecture.

On archeological grounds the ring could be either MB II or LB II but not later than the time of Ramses II. Since the writing shows relationships with the Tell ed-Duweir letters (ca. 1350-1250 B.C.) and likewise perhaps with the earlier Byblos (ca. 1400 B.C.) and 'Ain Shems (15th century B.C.) inscriptions, and also has some definite tendencies that are apparent in the Ahiiram inscription from Byblos (ca. 1250 B.C.), it is probable that on epigraphic grounds the date of the Megiddo ring should be limited to between 1350 and 1250 B.C.

<sup>215</sup> See Grimme *Altsinaitische Forschungen* ("Studien zur Geschichte und Kultur des Altertums" XX 3 [Paderborn, 1937]) Pl. XIV.

<sup>216</sup> See Grimme in *Archiv für Orientforschung* X 270 ff.

<sup>217</sup> "Ein neuer Inschriftenfund aus Byblos" (*Le Muséon* XLIX [1936] 85-98). See also Albright, *op. cit.* p. 10.

<sup>218</sup> One wonders whether this broken text contains abbreviations in the isolated letters or whether it will ultimately prove to be a sentence of short words rather than a single personal name.

## EARRINGS

Three types of earrings were found in the tombs. The earliest specimen (Fig. 178:1) came from a MB II burial. Apparently similar earrings of about the same period have been found at Tell el-cAjul.<sup>219</sup>

The second type (No. 2) is represented by two specimens (Pl. 128:7-8). They are both of "bronze" and came from a tomb chamber which contained MB II and LB II pottery. The closure is at the top, and there is no overlap. A third "bronze" earring (Pl. 128:6) from the same tomb chamber may be of the same type.

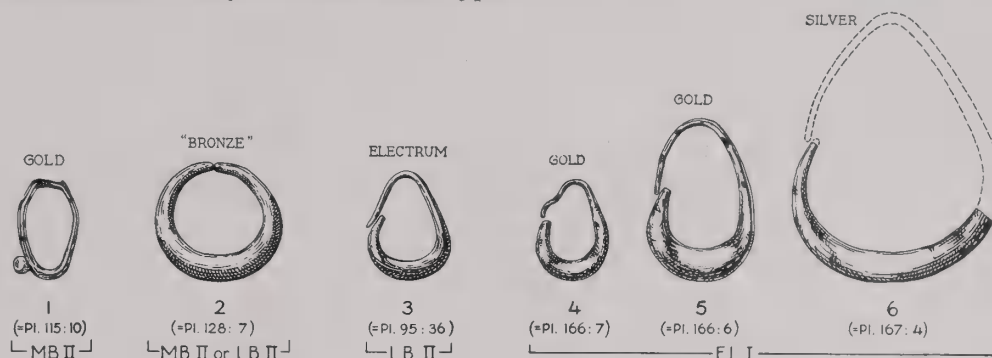

FIG. 178.—EARRINGS. ACTUAL SIZE

The third type (Nos. 3-6) was found in both LB II and EI I burials. No. 6 is notable for its size. Other specimens of the same type in gold (Pls. 119:10 and 128:1-4), silver (Pl. 128:5), and "bronze" (Pl. 135:9) are not as well dated as those shown in Figure 178.

A small "bronze" object (Pl. 127:1) found in a chamber containing MB II and LB II pottery may be part of an ear-stud.<sup>220</sup>

## BRACELETS

The finest specimen found (Fig. 179:1), from a LB I tomb, is made of silver. It was not ascertained how it was fastened, since one of the ends is fractured (see Pl. 145:22). The other LB I bracelet (No. 2) consists of a rounded "bronze" strip with ends tied. Nos. 3-5, of the same simple type, are either MB II or LB II on the basis of their pottery context.

Two types of bracelet (Nos. 6-7) were found in EI I deposits. No. 7, from an infant jar burial (T. 37 C 2), has overlapping ends; the other is a simple circle of iron. Another closed bracelet of iron (Pl. 137:14) was found on the arm of an infant in an EI burial (T. 37 B).

A fragment of drawn glass (Pl. 171:14), probably part of a bracelet, has been identified as Roman by Miss Christine Alexander of the Metropolitan Museum of Art, the fabric being common to the middle and late Roman imperial and post-classical periods.

Another bracelet type (Pl. 161:20-21) is not even approximately dated. Each end terminates in an animal head. Both specimens of this type are of "bronze."

## AMULETS AND PENDANTS

The amulets and pendants found in the tombs are isolated examples for the most part. Three came from MB II deposits. One (Pl. 115:25) is a pleasing object of gold inset with fayence. Another (Pl. 121:12) was perhaps intended to represent some animal form, and the third (Pl. 115:24) is clearly a model astragalus. In another MB II grave were found about seventy astragali, two of which had been rubbed down and polished (Pl. 115:11). Two such specimens were found at Tell Abu Hawam in Stratum V (ca. 1400-1230 B.C.).<sup>221</sup>

The only LB I pendant found (Pl. 152:11) is paralleled by crescent forms from elsewhere in

<sup>219</sup> Petrie, *Gaza IV*, Pl. XVIII 101 etc.

<sup>220</sup> Cf. Petrie, *Objects of Daily Use* (London, 1927) Pl. XVII 37-38.

<sup>221</sup> *QDAP IV*, Pl. XXXII 382.

Palestine. A gold specimen from Tell el-Ajul has been attributed to the early part of the 15th dynasty,<sup>222</sup> but earlier examples of the same type are known.<sup>223</sup>

In the LB II group are several specimens which follow Egyptian patterns. Five lotus seed-vessel pendants in carnelian were found, all probably LB II, though only one (Pl. 95:27) is well dated. This type appears to be of 19th to 20th dynasty date at Tell Fara.<sup>224</sup> A sacred eye

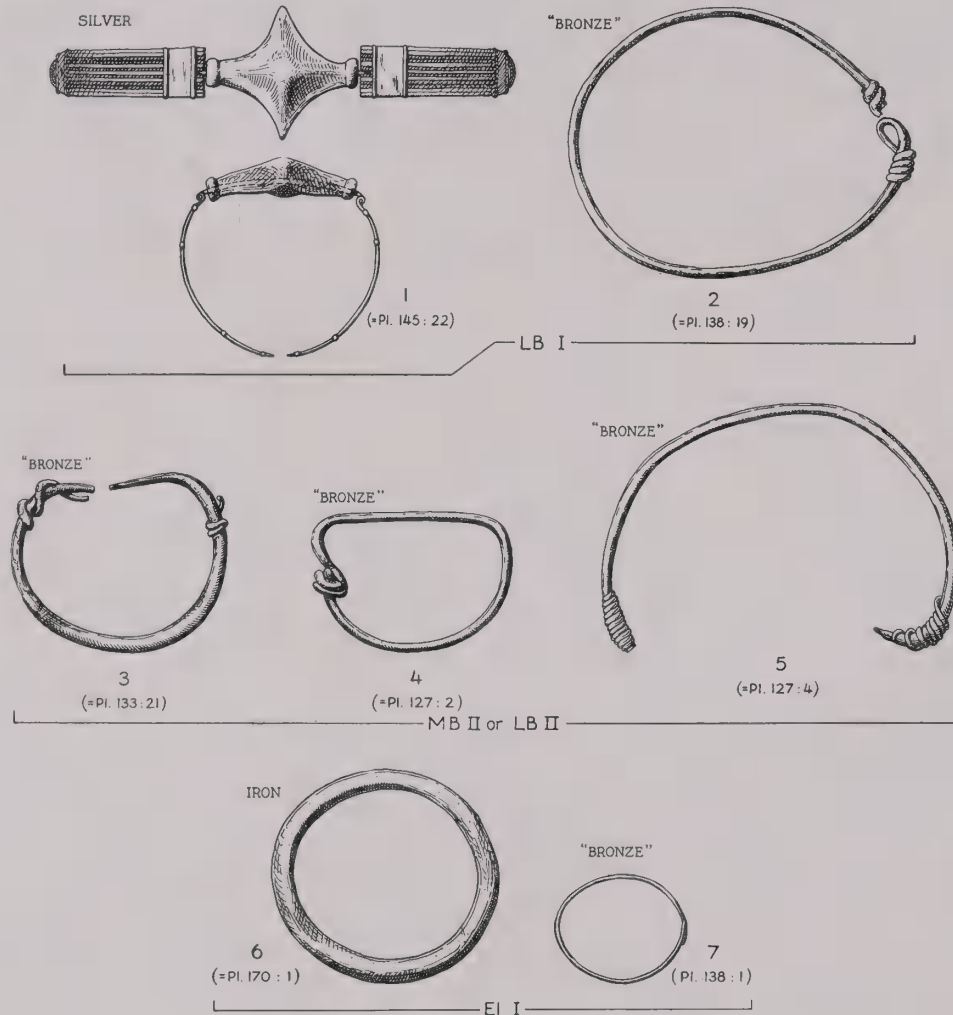

FIG. 179.—BRACELETS. SCALE, 1:2

(Pl. 95:4), three Bes figures (e.g. Pl. 95:2), and a figure which may represent Sekhmet (Pl. 95:3) are all of fayence and clearly of Egyptian origin. The last two were examined and dated by Petrie to the end of the 18th or the beginning of the 19th dynasty. Their context makes the 19th dynasty more probable. A fayence grape cluster (Pl. 156:7) should probably be dated LB II on the basis of evidence from other sites. At Tell Abu Hawam a grape cluster was found in Stratum V,<sup>225</sup> and several came from the priests' chamber behind

<sup>222</sup> Petrie, *Gaza* IV 9 and Pl. XX 174. <sup>223</sup> E.g. Macalister, *Gezer* III, Pl. XXXI 13 and 25; see also *ibid.* II 449 f.

<sup>224</sup> Starkey in J. Garrow Duncan, *Corpus of Dated Palestinian Pottery* (London, 1930) bead type V; *Beth-Pelet* II, Pl. LXXII type V.

<sup>225</sup> Hamilton in *QDAP* IV 65, No. 424, and Pl. XXXIX 424.

the temple sanctuary at Tell ed-Duweir.<sup>226</sup> Several have been found at Tell el-Amarnah also.<sup>227</sup>

In the EI I group two hollow gold pendants (Pl. 166:9) seem to represent pomegranates. Another pendant (Pl. 165:15) may represent a crocodile, but this suggestion is offered with no certainty. Mr. Keith Seele suggests that Plate 165:13 may represent Ptah-Sokar with a scarab on his head<sup>228</sup> or the ape as Thoth with the moon disk.<sup>229</sup> Further Egyptian influence in EI I is indicated by a Bes fragment (Pl. 165:14).

Two human leg models (Pl. 163:1-2) are attributed tentatively to MI on the basis of the texture of the pottery of which they are made. They may have been considered as possessing amuletic power.<sup>230</sup>

Undated specimens include a miniature ax of carnelian (Pl. 157:1), a seated figure and a sow in fayence (Pl. 161:1-2), a silver animal (Pl. 161:3), a fayence figure which Mr. Seele suggests may represent a standing ape<sup>231</sup> or "Nehebkau"<sup>232</sup> (Pl. 171:18), an Egyptian goddess in fayence (Pl. 173:3), and a perforated fossil gastropod (Pl. 173:13).

#### BEADS

About 800 beads were found in the tombs, but only a small proportion is well dated. Table IV lists types represented in the various periods. Only a few beads are decorated. Of these the type represented by Plate 95:8 appears, according to Petrie, to be a landmark for the period around 1300 B.C. Carnelian was used from very early times. It is interesting to note that the first glass was a bead (Pl. 110:17*d*) from the MB II period. Professor C. W. Parmelee, head of the Department of Ceramic Engineering at the University of Illinois, kindly arranged to have Dr. W. R. Morgan, of his staff, make a study of this bead. A brief report of Dr. Morgan's results follows:

#### MACROSCOPIC EXAMINATION

The bead was composed of two parts or types of material (A and B). Part A, the major portion of the bead, was relatively soft and had a pearly luster. Part B was a small blue core, relatively hard and glasslike, between the center and one side of the bead. The entire bead contained a network of small cracks, giving it a maplike appearance.

#### MICROSCOPIC EXAMINATION

Both parts, when examined in thin section, were found to be composed of isotropic material, the fragments of which were separated by a network of thin veins of crystalline material having high birefringence. The network of cracks visible to the eye and giving the surface of the bead a maplike appearance, then, was filled with crystalline material, formed either by alteration of the original material or by secondary deposition. In Part A the isotropic material was inclined to be "milky," while in Part B the centers of the isotropic fragments were clear and transparent.

When the isotropic material was powdered and immersed in oils, the index of refraction of that in Part A was found to be somewhat variable. Some fragments were slightly lower than 1.41, while most of the material had indices between 1.41 and 1.43. The isotropic material in Part B had an index of refraction between 1.500 and 1.512. The indices of the crystalline material were not determined because of difficulty in obtaining fragments free from isotropic material. The material, however, was observed to have relatively high birefringence.

<sup>226</sup> Starkey in *ILN*, July 6, 1935, pp. 19 f. and Fig. 6.

<sup>227</sup> Petrie, *Tell el Amarna* (London, 1894) Pl. XIX 441-48; Peet and Woolley, *The City of Akhenaten I*, Pl. XIII 2; Frankfort and Pendlebury, *The City of Akhenaten II* (London, 1933) Pl. XXIX 1.

<sup>228</sup> Cf. Petrie, *Amulets* (London, 1914) Pl. XXXI 176 f.

<sup>230</sup> Cf. *ibid.* Pl. I 15.

<sup>229</sup> Cf. *ibid.* Pl. XXXVII 206 h.

<sup>231</sup> Cf. *ibid.* Pl. XXXVII 204 b.

<sup>232</sup> Cf. Petrie, Brunton, and M. A. Murray, *Lahun II* (London, 1923) Pl. L, top row, 4th and 9th from left.

It was further noted upon examination of the original bead that small spherical cavities were present and that in some cases they were still filled with minute pellets of highly birefringent material. The pellets were of the order of 0.1 mm. in diameter.

#### X-RAY DIFFRACTION PATTERN

The X-ray pattern of Part A showed only one faint diffuse line after exposure for ten hours to radiation from a tube having an alpha-copper target, the tube being operated at 30 kilovolts and 20 milliamperes. Crystalline material ordinarily gives a good pattern with two to three hours exposure with the same tube. No conclusions can be drawn concerning the significance of the single faint line in the pattern, although the pattern may be said to indicate the absence of definite crystalline structure.

#### CHEMICAL ANALYSIS

A chemical analysis on a small amount of Part A showed the following results. Because of the small amount of material used, the accuracy was not as high as might be desired.

Loss on ignition . . . . .	13.18%
SiO <sub>2</sub> . . . . .	79.94
Al <sub>2</sub> O <sub>3</sub> +Fe <sub>2</sub> O <sub>3</sub> . . . . .	3.35
CaO . . . . .	3.41
MgO . . . . .	0.71
Alkalies . . . . .	not determined
	100.59

#### FUSIBILITY

Part A was infusible at 1400° C., while Part B was easily fusible in a gas flame at approximately 1000° C.

#### COLOR WHEN HEATED

Part A lost its pearly luster but did not change color appreciably. Part B first turned black without melting and upon further heating melted to a clear glass with a slight surface discoloration having the appearance and color of metallic copper. The amount of material was too small for identification.

#### DISCUSSION

The appearance of alteration and possibly of secondary deposition combined with the hardness and easy fusibility of Part B (blue core) and the softness and refractory character of Part A indicate that the original bead probably had been changed from its original character as indicated by Part B to that of Part A. In this alteration or weathering process the fluxes would have been leached from the bead, thus increasing its refractoriness and at the same time destroying the bond and producing a soft residue.

Both parts contained isotropic material, the index of refraction of Part B (blue core) corresponding to that of an ordinary soda-lime-silica glass, while the index of refraction of Part A corresponds to that of hydrated silica or opal-like materials such as siliceous sinters found around hot springs. The chemical analysis of Part A confirms the character as indicated by the index of refraction, since the material has a high loss on ignition and a high silica content. The X-ray pattern indicates that the weathered residue (Part A) is essentially non-crystalline, which would be expected if the siliceous residue were formed by the leaching of the fluxes from the glass.

The pearly luster on Part A was produced by the thin film of isotropic material with high birefringence which coated the exposed surfaces.

It seems probable that the bead originally was glass of the character of Part B (blue core) and was almost completely weathered to hydrated silica containing small amounts of alumina, iron, lime, and magnesia, as characterized by Part A.

TABLE IV  
TYPES OF WELL DATED BEADS

Type	Chalcolithic	MB I	MB II	LB I	LB II	E I I
Barrel disk				shell (Pl. 135:15f)		
Short barrel	carneian (Pl. 84:19)	fayence (Pl. 101:8)		"bronze" (Pl. 138:15c) carneian (Pl. 135:15a) fayence (Pl. 138:16a) glass (Pl. 148:15) marble (Pl. 135:15d)		carneian (Pl. 165:19a) gold (Pl. 168:12)
Fluted				carneian (Pl. 152:6)		
Standard barrel						carneian (Pl. 168:11h)
Long barrel			carneian (Pl. 110:17a) fayence (Pl. 115:19c)	carneian (Pl. 147:12g) chalcedony (Pl. 135:15c) marble (Pl. 138:15b)	carneian (Pl. 95:14) fayence (Pl. 95:7)	carneian (Pl. 168:11d) diorite? (Pl. 168:11b) glass (Pl. 138:5b)
Lenticular					carneian (Pl. 95:13)	
Lenticular fluted						fayence (Pl. 165:19j)
Ellipsoid With irregular ends						glass (Pl. 165:19g, k)
Lenticular				opal (Pl. 152:7)		
Short truncated bicone				carneian (Pl. 135:15b)		carneian (Pl. 165:19c) chalcedony (Pl. 165:19l)
Convex					carneian (Pl. 95:22)	carneian (Pl. 168:11c)
Long truncated bicone						carneian (Pl. 165:19f) carneian (Pl. 168:11e)
Convex						
Long pear shape				carneian (Pl. 147:12f)	carneian (Pl. 95:11)	
Cylinder disk				bone (Pl. 152:8, 10) shell (Pl. 146:7)		
Rectangular						shell (Pl. 138:4)
Short cylinder						composition (Pl. 165:19i) fayence (Pl. 165:19h)
Standard cylinder		fayence (Pl. 101:7)				carneian (Pl. 168:11g)
Long cylinder			composition (Pl. 110:17e) fayence (Pl. 115:19a)	carneian (Pl. 147:12c) composition (Pl. 138:15e) glass (Pl. 135:15g)		
With 1 convex end				fayence (Pl. 145:20)		
Circular				amethyst (Pl. 138:15d)	glass (Pl. 95:10)	
Fluted				carneian (Pl. 147:12e)		
Tabular, with convex ends					glass (Pl. 95:8)	
Oblate disk			fayence (Pl. 121:11)			
Oblate			fayence (Pl. 121:10) glass (Pl. 110:17d)	glass (Pl. 135:15e)	fayence (Pl. 95:5)	carneian (Pl. 168:11i) fayence (Pl. 165:19m)
Fluted			fayence (Pl. 113:16)	fayence (Pl. 147:12b)		
Rayed (star-shaped)					fayence (Pl. 95:6)	
Long lenticular faceted						carneian (Pl. 168:11a)

## CYLINDER SEALS

The relationship observed between designs on pottery from Billah III and from LB I Megiddo (see p. 153) quite naturally suggested the possibility of finding parallels in other types of objects from contemporary deposits in upper Iraq. It happens that at the site of Nuzi, not far from Tell Billah, many tablets bearing cylinder seal impressions were found in deposits approximately contemporary with Billah III.<sup>233</sup> Though the glyptic material on those tablets is largely unpublished, it was made available to us through the courtesy of Professor E. A. Speiser, director of the American School of Oriental Research in Baghdad. Examination of the material revealed abundant parallels for some of the Megiddo seals as well as for some from other Palestinian sites.<sup>234</sup> Professor Speiser informs us that numerous seals like those from Nuzi were found in Billah III (*ca.* 1600–1400 B.C.), with some occurring as well in the overlying stratum of the 13th century.<sup>235</sup> This distribution coincides with that at Megiddo, where the latest seals were found in context contemporary with Ramses II.



FIG. 180.—MEGIDDO AND NUZI CYLINDER SEAL IMPRESSIONS. ACTUAL SIZE

Of the eight cylinder seals included in this volume, six are referable to Nuzi examples (see Figs. 180–83). Five of the Megiddo seals are well dated, being LB I (Fig. 181:1 and Pl. 148:1) and LB II (Fig. 183:1 and Pls. 94:3 and 95:33). Of the other three, one (Fig. 182:1) found with MB II and LB II pottery is placed tentatively in LB II on the basis of the well dated specimens and a LB II parallel from the tell. Another (Pl. 90:8) is assigned tentatively to LB I on linguistic evidence. The third (Fig. 180:1) was found in débris not associated with a tomb but is considered as LB because it has excellent parallels among Nuzi type seals (Fig. 180). These parallels have artistic treatment in common with the Megiddo seal in Figure 180.<sup>236</sup>

<sup>233</sup> See Speiser in *MJ* XXIII 273–75.

<sup>234</sup> E.g. Gezer (Macalister, *Gezer* III, Pls. CCII and CCXIV), Beisan (Rowe in *ILN*, Oct. 30, 1926, p. 829, Fig. 3), and Tell Abu Hawam (Hamilton in *QDAP* IV, Pl. XXXVIII 406–10).

<sup>235</sup> For a discussion of the dating of Nuzi tablets see Speiser in *American Oriental Society, Journal* XLIX (1929) 269–75. The tablet on which he bases his discussion is published by R. H. Pfeiffer, *The Archives of Shilwateshub, Son of the King* (“Harvard Semitic Series” IX [1932] No. 1).

<sup>236</sup> For Kirkuk (or style of Kirkuk) parallels see G. Contenau in *Babyloniaca* IX (1926) Figs. 83 and 107; Contenau, *La glyptique syro-hittite* (Paris, 1922) Nos. 283–86; William H. Ward, *The Seal Cylinders of Western Asia* (Washington, D.C., 1910) Fig. 1003; O. Weber, *Altorientalische Siegelbilder* (“Der Alte Orient” XVII–XVIII) II (1920) No. 267. For an example from Assur see Weber, *op. cit.* No. 470. A specimen from Cyprus is to be seen in Ward, *op. cit.* Fig. 1170.

The crowded effect is much the same, as is the cutting in low rounded relief and the technique of forming or accentuating certain parts of the design with a fine drill. The latter is characteristic of other Nuzi material also. As for the details of the designs, there is likewise much in common. It is clear that the tree in each is a product of the same convention. Many other trees belonging to the same family occur on Nuzi tablets (see e.g. Figs. 181:4 and 183:4). Another comparable element is the antithetic arrangement of tree and animals in Nos. 1-2. Nos. 1 and 3 each show a harpoon-headed fish and bodiless animal heads.

The seal impressions in Figure 181 are concerned with another type of representation. The Nuzi specimens are adduced for their files of men, for, though it is clear that the Megiddo seal was not as perfectly cut and may therefore have been made in Palestine, it is quite as apparent that a common tradition lay behind all of them. The file of men in the Nuzi glyptic repertoire is by no means restricted to the three impressions reproduced here, and in most cases relationship with the Megiddo seal is certain. Other elements shared by the impressions in Figure 181

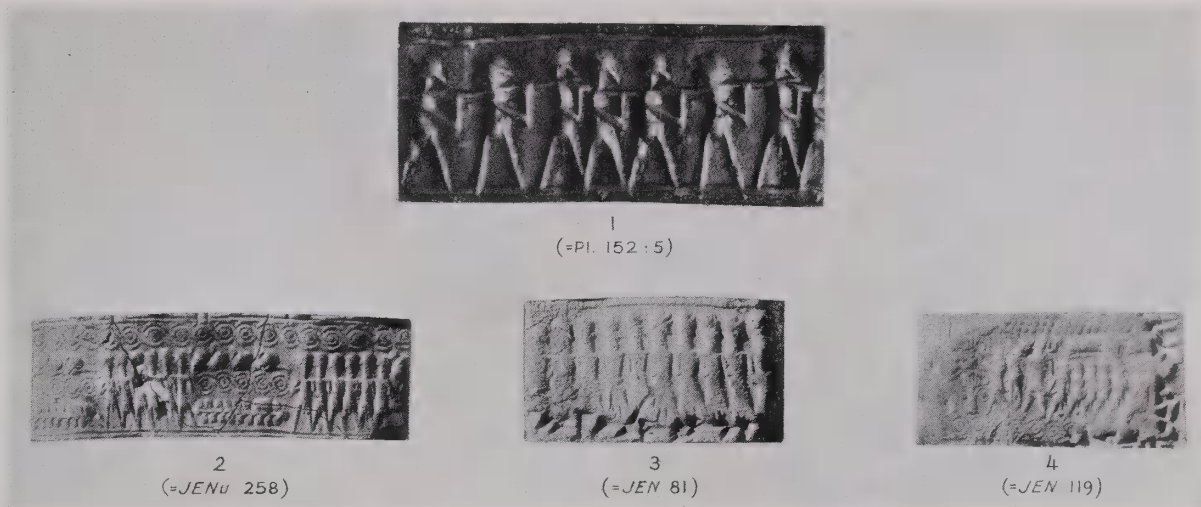

FIG. 181.—MEGIDDO AND NUZI CYLINDER SEAL IMPRESSIONS. ACTUAL SIZE

are the style of headdress, beaked faces, square shoulders, arm positions, short tunics extending a little below the waist and ending in tassels, and finally the position of the legs. Each man in the Megiddo seal rests his right hand on the shoulder of his predecessor, and this detail, with positions reversed, may possibly appear in No. 3 also. It is certain at any rate that the left arms of the men in the Nuzi seal are not at their sides. Another very good parallel for the Megiddo example is to be seen in the Kirkuk material published by Scheil.<sup>237</sup>

The seal impressions in Figure 182 have as their principal theme a conventionalized tree balanced by two garbed figures. The tree in the Megiddo impression is even simpler than the others. The headdresses are essentially the same, even to the braids which fall from beneath them. The peculiar up-turn and final down-twist of the braid on the left-hand Megiddo figure is repeated in most of the Nuzi figures. Each of the personages in the Megiddo impression wears a mantle which covers the arm and shoulder near the tree and leaves the other arm uncovered. The hand of the bare arm rests on the hip. The same type of garment occurs in each of the Nuzi impressions. The posture too is similar, except in No. 4, where one undraped arm hangs at the side and holds a weapon(?). Another point of comparison lies in the scroll design on Nos. 1 and 4. This pattern fills the entire field in still another Megiddo seal (Pl.

<sup>237</sup> RA XV (1918) 69 (seal of Aršeihli); cf. also *ibid.* seal of Irpinuḫni.

94:3). But the scroll is widespread in its occurrences;<sup>238</sup> other Palestinian sites have contributed examples,<sup>239</sup> and in the Nuzi tablets the scroll occurs frequently.

The impressions in Figure 183 are presented for the type of wing structure seen on the animals. A straight line forms the backbone of the wing, while other lines represent the feathers.<sup>240</sup> Other elements in common are a somewhat similar head style in the animals of Nos. 1–3 and the drill technique in all four. Of course the seals cannot be compared on the basis of composition, for the treatment accorded the Megiddo specimen gives its figures agility and life not possessed by the Nuzi examples.

One Megiddo seal (Pl. 90:8) differs in style from all the others. It contains a conventional prayer, quite possibly to Marduk. Professor Edward Chiera compared it to certain Nuzi seals (see opp. Pl. 90).

The two Megiddo seals for which no Nuzi parallels have been noted (Pls. 95:33 and 148:1) belong conceivably to the same general group as those already discussed.



FIG. 182.—MEGIDDO AND NUZI CYLINDER SEAL IMPRESSIONS. ACTUAL SIZE

Since some of the motifs used on Nuzi type seals had a widespread occurrence in the Near East, the source of such seals remains obscure. But it seems quite certain that they did not appear in Palestine until the LB I period, and are thus linked to the pottery with “Hurrian” designs comparable to that from Billah III (see p. 153), which in turn is approximately contemporary with the tablet deposits at Nuzi (see p. 182, n. 233). The Megiddo LB I deposits, culturally speaking, can only be considered as late Hyksos (in which the “Hurrian” element is recognized as being very important). Answers to the questions that arise from the nature of the evidence will probably be settled only by further excavation and comparison of middle 2d millennium material from north of Palestine, whence Palestine derived some of its late Hyksos culture before passing it on to Egypt.

#### SCARABS AND SCARABOIDS

The tombs yielded no scarabs or scaraboids earlier than MB II. But from burials of that period, some of which may be as early as the 19th century B.C. (T. 911–12), came a number sufficient to enable us to formulate certain generalities regarding scarabs of the early Hyksos

<sup>238</sup> Cf. a Cypriote seal in D. G. Hogarth, *Hittite Seals* (Oxford, 1920) Fig. 73.

<sup>239</sup> E.g. Tell Abu Hawam (Hamilton in *QDAP* IV, Pl. XXXVIII 406) and Gezer (Macalister, *Gezer* III, Pl. CCXIV 17).

<sup>240</sup> For a Kirkuk parallel for this type of wing see V. Scheil in *RA* XV 72 (seal of Mar Šiphalu).

period at Megiddo. Steatite, glazed or unglazed, was the most common material but was not restricted to MB II.<sup>241</sup> The only other materials for this period are amethyst, fayence, and green jasper. Geometric patterns, including scroll and rope designs, are characteristic. Elements of designs are often filled with a mesh.<sup>242</sup> Hieroglyphs are poorly formed and usually apparently meaningless or purely decorative. A variation of the "mouth, arm, and line with cross-bars," a motif which Brunton has noted as occurring often on Hyksos scarabs,<sup>243</sup> appears on one Megiddo specimen (Pl. 106:1). Some scarabs seem to express good wishes. All of these traits are illustrated by specimens from T. 24 (Pls. 105-6), which show also the physical form of early Hyksos scarabs.<sup>244</sup>

LB I deposits have been regarded as Hyksos (see p. 153) in part because scarabs present in burials of this period (Pls. 137:1-7, 138:14, 147:2, and 152:1-4) exhibit some of the characteristics of those from the previous period.<sup>245</sup> The LB I specimens are all of steatite, either glazed or unglazed.

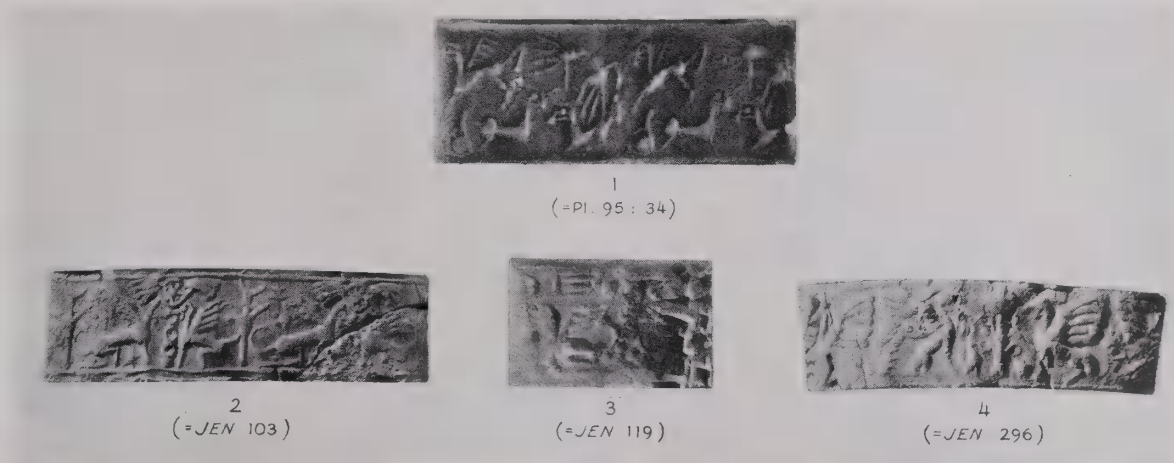

FIG. 183.—MEGIDDO AND NUZI CYLINDER SEAL IMPRESSIONS. ACTUAL SIZE

Form and character of inscriptions changed considerably soon after the beginning of the Egyptian Empire. In general, LB II scarabs have lower backs and are marked more clearly with the scarabaeus characteristics. One has a fish back (Pl. 100:8). Hieroglyphs, though not always clear, are more legible. The names of Thutmose III (e.g. Pl. 131:4) and Ramses II (e.g. Pl. 100:5) occur. Materials are steatite, fayence, and carnelian.

Scarabs and scaraboids from EI I context are all shown on Plate 165. Occurrences of the prenomen of Thutmose III on Nos. 1 and 10 is not surprising in view of the known predilection of the later Egyptians for scarabs bearing that king's name. The back of No. 11 is carved to

<sup>241</sup> It is the most common material for all periods at Megiddo. See Newberry, *Scarabs* (London, 1908) p. 84, for statement regarding the general use of steatite in Egypt from the 12th to the 20th dynasty.

<sup>242</sup> Cf. *ibid.* Pl. XXV. But see Hall, *Scarabs*, Nos. 1264-65, for later use of such mesh.

<sup>243</sup> Petrie and Brunton, *Sediment I* 20. Cf. Newberry, *Scarabs*, Pl. XXIV, and Albright, *AASOR XII* 32 f. and Fig. 5.

<sup>244</sup> Cf. Newberry, *Scarabs*, pp. 72 f.

<sup>245</sup> The mouth, arm, etc. hieroglyphic grouping was not found in LB I at Megiddo, but there is an Egyptian example as late as Amenhotep I (Guy Brunton and Reginald Engelbach, *Gurob* [London, 1927] Pl. XXII 9). Its publishers suggest that this scarab, with others from the same tomb, appears to be of the 2d intermediate period (*ibid.* p. 10). But in view of the great number of Hyksos styles represented (*ibid.* Pl. XXII), it seems likely that the older fashion still had influence in the early 18th dynasty in Egypt. For Palestine we regard Hyksos type scarabs as normal until about the time of Thutmose III. See also Hyksos style scarabs from other tombs at Ghurab dated to the time of Amenhotep I and Thutmose III (*ibid.* Pls. XXIII, Tomb 26, and XXIV, Tomb 84).

represent an ape. Another scarab with ape back (Pl. 176:6), though found out of context, can possibly be dated EI I by analogy. In addition to steatite the materials used during this period were fayence, carnelian, and glass.

## INLAYS

The use of bone inlays was apparently introduced to Megiddo during MB II (Pls. 108-9, 111, and 113:18),<sup>246</sup> while the same technique and tradition continued in LB I (Pls. 145:2 and 152:14). An EI I piece with guilloche pattern reveals a technological advance in that it is morticed (Pl. 166:20). Found in the same tomb were seven rectangular pieces of a type heretofore unknown at Megiddo (Pl. 166:21). Two of these were incised by compass with a symmetrical six-leaved configuration.

Other bone objects with incised decoration, some of them associated with fragments of wood, may have been inlays (Pls. 100:21 and 130:4-7). An EI I object of ivory decorated with incised straight lines (Pl. 166:13) is clearly related.

An interesting ivory inlay in the shape of an Ionic volute (Pl. 172:1) should probably be dated MI on the basis of an 8th or 9th century B.C. ivory from Samaria embodying the same idea.<sup>247</sup> Although the tomb from which the Megiddo specimen came yielded a mixed deposit, most of the pottery is MI (see Pl. 74:9-13).

## VESSELS OTHER THAN POTTERY

## STONE

Basalt, a fairly common rock in the Megiddo region, was used throughout the history of the site for vessels, usually broad open bowls. A Chalcolithic vessel from T. 1106 (Fig. 21) has projections similar to those occurring on pottery bowls of gray burnished ware from T. 903 Lower (cf. Pl. 3:31-32). Probably the latest specimen is a three-legged bowl (see opp. Pl. 175) from a late Roman burial (*ca.* A.D. 400), though many of the basalt vessels from the tombs are undated.

Two Egyptian "alabaster" (see p. 6) jars (Fig. 184:1-2) are attributed to MB II on the basis of similar specimens found in Hyksos deposits at Tell Beit Mirsim<sup>248</sup> and Tell Fara.<sup>249</sup> No. 2 was found in a tomb which contained both MB II and LB II pottery. The same type has been found in Syria<sup>250</sup> and Egypt.<sup>251</sup>

The same general type of "alabaster" vessel was found in LB I burials also (Nos. 3-5), and one diorite specimen (No. 6) was recovered. The resemblance between MB II and LB I pieces serves again to demonstrate the close relationship of early and late Hyksos cultures. But from LB I tombs came three "alabaster" vessels of types not seen earlier (Nos. 7-9).<sup>252</sup>

By LB II times all prior forms seem to have been replaced. Two "alabaster" jars with vertically pierced lug handles (see opp. Pl. 94) are the only specimens which can be dated LB II by their context. One vessel (Fig. 184:11) is assigned to LB II because it has horizontal loop

<sup>246</sup> For contemporary inlays see Petrie, *Gaza* III 40 and Pl. XXIX. At Alishar similar strips occurred in the period of the Hittite Empires (Stratum II); see *OIP* XIX 80 and Fig. 225; XXIX, Fig. 275 (top). For similar pieces in ivory from Troy IV see Schliemann, *Ilios*, p. 566. A long bone strip decorated with concentric circles was found in a Middle Helladic grave at Eleusis (George E. Mylonas in *AJA* XXXVI [1932] 111 and Fig. 14).

<sup>247</sup> J. W. Crowfoot in *PEFQS*, 1932, p. 133 and Pl. III; but see *ILN*, June 21, 1933, p. 84, Fig. 5, for a better reproduction.

<sup>248</sup> See Albright, *AASOR* XII 27-29 and Pls. 9, No. 3; 42, No. 3; and 43, No. 2.

<sup>249</sup> *Beth-Pelet* II, Pl. XLII (Tomb 1004).

<sup>250</sup> Montet, *Byblos et l'Égypte*, Pl. CXVIII 786 (from a tomb contemporary with the 12th dynasty).

<sup>251</sup> E.g. Petrie and Brunton, *Sedment* I, Pl. XLI 2-3 (16th dynasty).

<sup>252</sup> Cf. Petrie, *Gaza* III, Pl. XXVI 27; IV, Pl. XXXIX 33, 35, and 67.

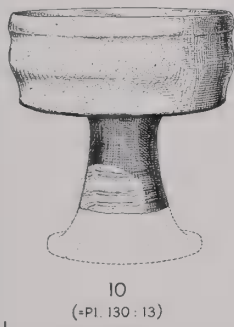
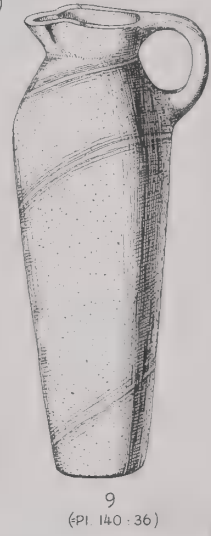
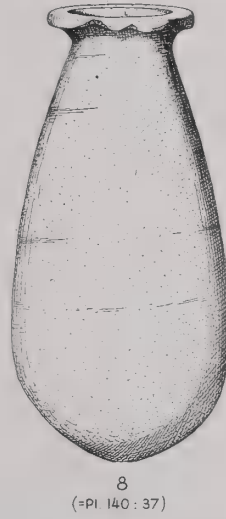
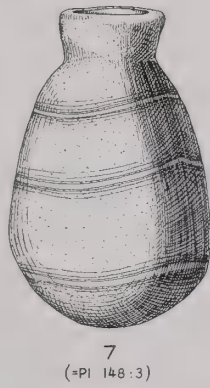
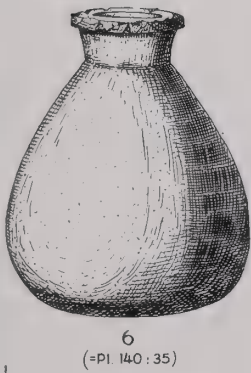
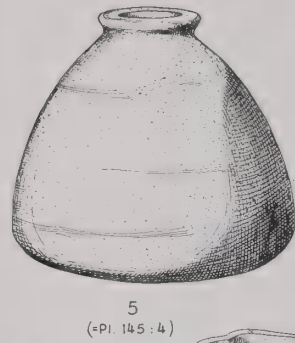
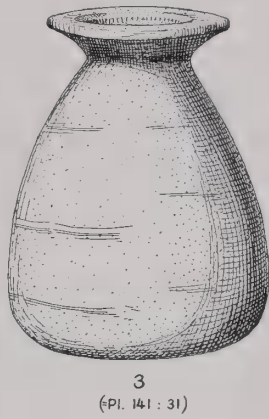
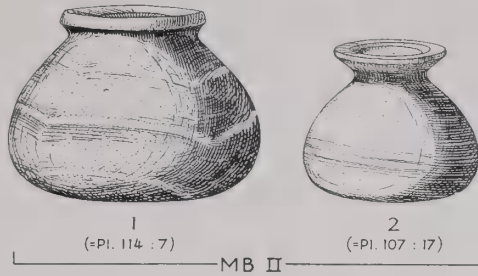

FIG. 184.—EGYPTIAN "ALABASTER" AND DIORITE (NO. 6) VESSELS. SCALE, 2:5

handles, one of the distinctive traits of LB II pottery (see p. 157), though both MB II and LB II pottery were found in the tomb from which it came. Another "alabaster" specimen from the same tomb (No. 10) is dated LB II because vessels like it are known elsewhere in LB II Palestine<sup>253</sup> and at Minet el-Beida.<sup>254</sup>

The only EI I specimen (No. 12) has horizontal loop handles, but its original rim form is unknown, since it had been broken and rubbed down.

## FAYENCE

Of the three fayence vessels recovered from the tombs, one (Fig. 185:1) clearly follows pottery tradition in its form, although the banding may have been in imitation of "alabaster." Another (No. 2)<sup>255</sup> seems to resemble a metal form. The third (Pl. 173:7) is undated but appears to be Egyptian.

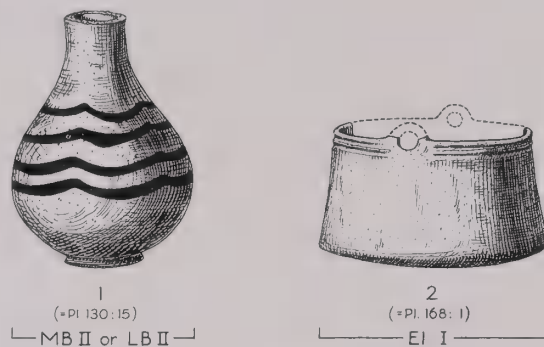

FIG. 185.—FAYENCE VESSELS. SCALE, 2:5

## IVORY

Two duck-shaped ivory toilet boxes were found in the tombs, one from MB II context (Pl. 104) and the other from LB I (Pl. 142:1).<sup>256</sup> Similar containers and fragments thereof have been found elsewhere,<sup>257</sup> some in LB II contexts.

## "BRONZE"

Whether "bronze" vessels were used earlier than LB II at Megiddo has not been ascertained. Two saucers (Fig. 186:1-2) were found in a tomb chamber containing disturbed MB II and LB II pottery. Two EI I specimens (Nos. 8-9) are similar to two types of bowls found in LB II burials (Nos. 5 and 7). A vessel approximating the LB II vase (No. 3) came from the "Governor's Tomb" at Tell el-Ajul.<sup>258</sup>

A "bronze" offering-stand (No. 4) of the LB II period, upon which a pottery bowl once stood (see p. 65), is comparable to several found by Schumacher.<sup>259</sup>

<sup>253</sup> See e.g. *Beth-Pelet II*, Pl. XLVIII 13 and 20.

<sup>254</sup> *Syria XIII*, Pl. VIII 1.

<sup>255</sup> Cf. a similar form called porcelain in Murray, Smith, and Walters, *Excavations in Cyprus*, Fig. 63, No. 1047.

<sup>256</sup> For a similar and approximately contemporary example from North Syria see Woolley in *ILN*, Oct. 9, 1937, p. 604, Fig. 2.

<sup>257</sup> E.g. Macalister, *Gezer II* 118 and Fig. 293; Bliss and Macalister, *Excavations in Palestine*, pp. 147 f. and Pl. 77, No. 10 (from Tell es-Safi); Starkey, "Excavations at Tell el Duweir, 1933-34" (*PEFQS*, 1934, pp. 164-75) Pl. VII 2 (upper left); *Beth-Pelet II*, Pl. LVII 361 (19th-20th dynasty); *Syria XIII*, Pl. VIII 2 (from Minet el-Beida). Mr. Guy reports a specimen in the British Museum from a Mycenaean tomb at Ialysos, Rhodes.

<sup>258</sup> Petrie, *Gaza III*, Pl. VIII 16.

<sup>259</sup> Schumacher, *Tell el-Mutesellim I* 84 f. and Pl. L; Watzinger, *Tell el-Mutesellim II* (Leipzig, 1929) 26-31.

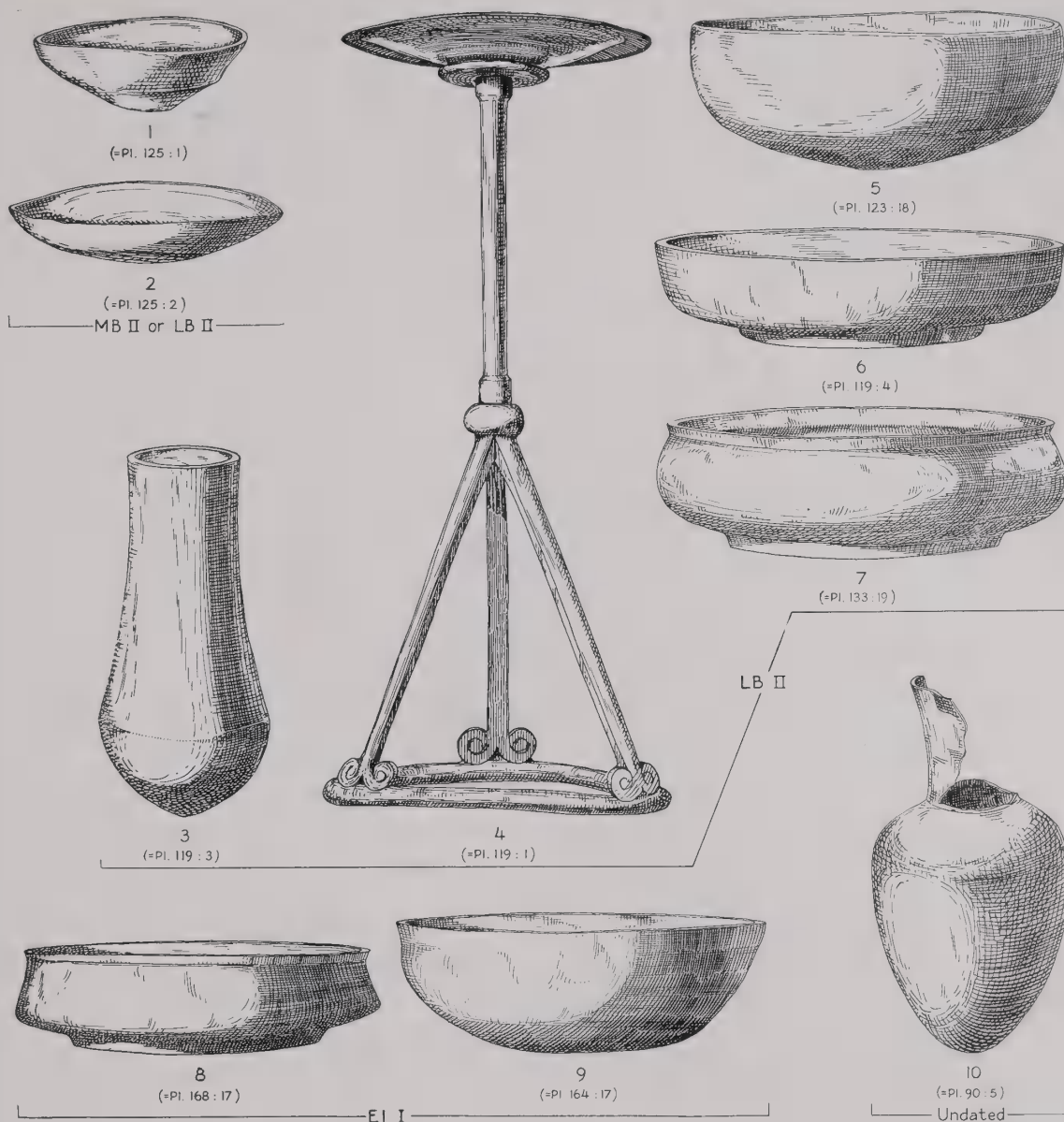

FIG. 186.—“BRONZE” VESSELS AND A “BRONZE” OFFERING-STAND. SCALE, 2:5

## GLASS

The only true glass vessels found came from a late Roman grave (Pl. 175:6–11 and 13). Miss Christine Alexander of the Metropolitan Museum examined photographs of these and contributed the following notes and bibliography. All appear to be of the middle or late Roman imperial period. Nos. 6–7 are of Syrian fabric,<sup>260</sup> and Nos. 11 and 13 seem to be *opus diatretum* (network).<sup>261</sup> Though this rare fabric apparently lasts into post-classical times, the pieces in question are Roman in shape.

<sup>260</sup> Cf. Robert Zahn, *Sammlung Baurat Schiller* (Berlin, 1929) Nos. 299 and 266–67 respectively.

<sup>261</sup> Cf. Anton Kisa, *Das Glas im Altertume* (Leipzig, 1908) II 442 ff., and Fritz Fremersdorf in *Archäologischer Anzeiger. Beiblatt zum Jahrbuch des Deutschen archäologischen Instituts* XLVI (1931) 132 ff. For Nos. 9–10 cf. Kisa, *op. cit.* p. 426.



TABLE V—Continued

PERIOD	OBJECTS AND TYPES FOUND AT MEGIDDO	FOREIGN RELATIONSHIPS				SEE PAGE
		Parallels in	Imports from	Local Imitations of Works of	Idea Derived from	
LB II ca. 1400–1200 B.C.	Development of "Hurrian" motifs in one color					156
	Stirrup cups		Mycenaean area			157
	Squat jars			Mycenaean area		157
	Craters			Mycenaean area		157 f.
	Cypriote white slip ware		Cyprus	Cyprus		158
	Cypriote base-ring ware		Cyprus	Cyprus		158
	Cypriote <i>bucchero</i> ware		Cyprus	Cyprus		158
	Jar forms { e.g. Pl. 17:13	Egypt, Syria Egypt?				155
	{ e.g. Pl. 57:9					155
	Juglets with pinched lip					155
	Shaved juglets					155
	First "cups and saucers" and flasks					155
	Bronze		Asia Minor?			161 (Table II)
	Iron (1 piece)					162
	Amulets, pendants, scarabs	Egypt (Empire)				178, 185
	Egyptian "alabaster" vessels	Syria				186–88
	Tanged daggers	Syria				165
Knives with rounded blade end					165	
"Recurved" knife					165	
Cylinder seals (3)	Nuzi, Kirkuk, Tell Billah				182–84	
Gold ring bearing Old Canaanite script					173–76	
"Bronze" vessels					188	
EI I ca. 1200–1100 B.C.	Pottery largely dependent on LB II forms and decoration					159
	First truly Philistine ware (2 bowls)		Aegean area?		Aegean area	159
	Decorated sherds (Pl. 8:1)					160
	Bronze		Asia Minor?			161 (Table II)
	Iron (4 pieces)					162
	Knife with rounded blade end					165
	Amulets, scarabs	Egypt				179, 185 f.
	Gold medallion bearing "royal" or "Cappadocian" symbol	Anatolia				162 f.
	"Bronze" vessels (2)					188
	Fayence vessel	Cyprus?				188

## V

## SKELETAL REMAINS

By ALEŠ HRDLIČKA

Curator, Division of Physical Anthropology  
United States National Museum, Washington, D.C.

The material received was very fragmentary. Not a single skull was found entire, and in many cases, even with the best efforts at reconstruction, little of scientific value could be obtained. A small number of lower jaws (e.g. Fig. 187) and long bones are in a better state of preservation. Nevertheless, the material when arranged chronologically proves to be of considerable interest.

*Chalcolithic.*—Twenty-eight skulls (e.g. Figs. 188–92),<sup>1</sup> some very fragmentary. All of the specimens are of the Mediterranean type of people, except for the skull of a young female with Negroid features (Fig. 188).

*Early Bronze (Stage 0–I).*—Nine skulls (e.g. Figs. 193–94),<sup>2</sup> more or less fragmentary. The type remains the same as that of the preceding group, that is, Mediterranean.

Up to and including this stage females and the young predominate.

*Middle Bronze II.*—Two skulls,<sup>3</sup> both fragmentary. The type is different from that occurring in the previous periods. It is that of whites, but the vault of the skull is distinctly shorter and broader. Regrettably the faces are missing.

*Late Bronze.*—Sixteen skulls (e.g. Figs. 195–97),<sup>4</sup> more or less damaged. The type of population has now definitely changed from the Mediterranean to that of the two shorter and broader heads found in MB II. The Mediterranean type has very nearly disappeared, there being only two such skulls in the lot (H 109 and H 184 [Fig. 197]), both females. The prevalent type approaches that of the Alpines.

*Iron Age.*—Thirteen skulls (e.g. Figs. 198–202),<sup>5</sup> all more or less imperfect. Two female skulls (H 145 and H 160) are of the Mediterranean type. Nine show the same type as those of the LB period. One (Fig. 200), which so far as the vault is concerned is close to the majority, presents a face that may perhaps be described as grossly Assyroid.

Throughout MB II and later periods male skulls are fairly numerous to predominant.

The skulls, it is seen, show a marked grouping, with a change of population occurring in MB II, though for that period only two skulls are available. The differences between the two skull types are more striking when the materials are viewed in mass than can be shown by the measurements (Table VI), which suffer greatly from the more or less imperfect condition of the skulls. The earlier type is remarkably pure, the later evidently somewhat mixed. Both peoples were of moderate to medium stature, but the later type was the sturdier. The earlier type is marked mostly by excessive dolichocephaly combined with relatively low vault of the skull. The later type, though low vaulted, is characterized by broader and generally fuller skull (Fig. 203). Both peoples were unquestionably branches of the white race, but not related branches. The earlier type may probably be ranged with the early Mediterraneans; the later when inspected in bulk appears to bear resemblance to the Alpines.

<sup>1</sup> Nos. H 14–16, H 23–24 (T. 1103); H 26–27 (T. 910 A); H 40, H 43, H 46, H 51–54, H 58, H 62–63, H 66, H 72, H 77–80 (T. 903 Upper); H 84–86 (locus 1184 [a house in square U 17; see Pl. 2]); H 87 (T. 1127); and H 88 (T. 1126).

<sup>2</sup> Nos. H 1–5, H 7–10 (T. 1101 B Lower).

<sup>3</sup> Nos. H 116, H 121 (T. 911 A 1).

<sup>4</sup> Nos. H 102–5, H 107–10 (T. 1100 A); H 173 (T. 921); H 179–80 (T. 25); H 181–85 (T. 36).

<sup>5</sup> Nos. H 145 (T. 950); H 153 (T. 1265; published in *OIP XLII*); H 154 (T. 1277; published *ibid.*); H 155 (T. 1291; unpublished); H 156–57 (T. 1276; published *ibid.*); H 160–63 (T. 1090 C); H 167–69 (T. 232, possibly as late as the classical period).



FIG. 187.—CHALCOLITHIC AND LB I MANDIBLES. SCALE, 2:5

- |   |   |
|---|---|
| 1 = H 31 ♀ (T. 910 B) Chalcolithic      | 5 = H 190 ♀ (T. 903 Upper) Chalcolithic |
| 2 = H 187 ♀ (T. 903 Upper) Chalcolithic | 6 = H 141 juvenile (T. 1178) LB I       |
| 3 = H 188 ♂ (T. 903 Upper) Chalcolithic | 7 = H 144 ♀ (T. 856) LB I               |
| 4 = H 189 ♀ (T. 903 Upper) Chalcolithic |   |

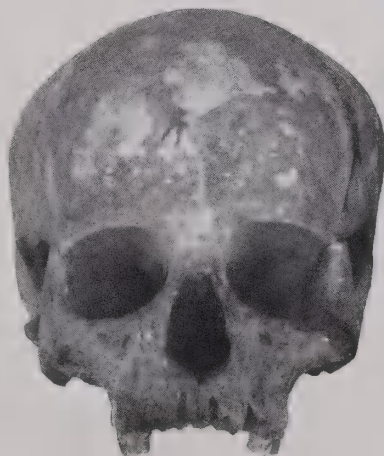

FIG. 188.—CHALCOLITHIC FEMALE SKULL (H 78) FROM TOMB 903 UPPER (SEE FIG. 6). SCALE, 2:5



FIG. 189.—CHALCOLITHIC MALE SKULL (H 40) FROM TOMB 903 UPPER (SEE FIG. 5). SCALE, 2:5



FIG. 190.—CHALCOLITHIC MALE SKULL (H 46) FROM TOMB 903 UPPER (SEE FIG. 5). SCALE, 2:5



FIG. 191.—CHALCOLITHIC FEMALE SKULL (H 26) FROM TOMB 910 A (SEE FIG. 13). SCALE, 2:5



FIG. 192.—CHALCOLITHIC MALE SKULL (H 23) FROM TOMB 1103. SCALE, 2:5



FIG. 193.—EB (STAGE 0-I) ADOLESCENT FEMALE SKULL (H 1) FROM TOMB 1101 B LOWER (SEE FIG. 26). SCALE, 2:5



FIG. 194.—EB (STAGE 0-I) MALE SKULL (H 2) FROM TOMB 1101 B LOWER (SEE FIG. 26). SCALE, 2:5

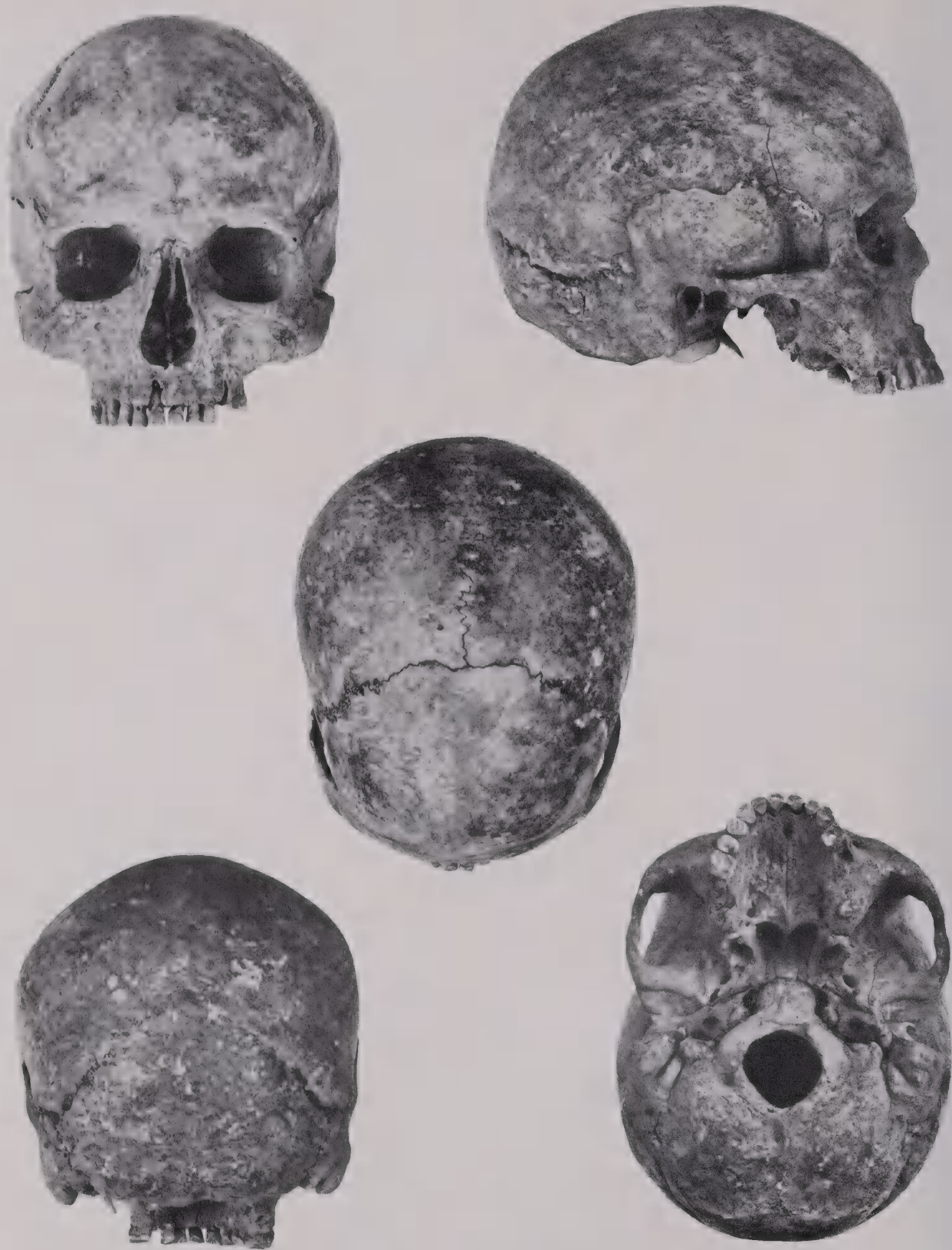

FIG. 195.—LB I MALE SKULL (H 104) FROM TOMB 1100 A. SCALE, 2:5



FIG. 196.—LB I MALE SKULL (H 110) FROM TOMB 1100 A. SCALE, 2:5

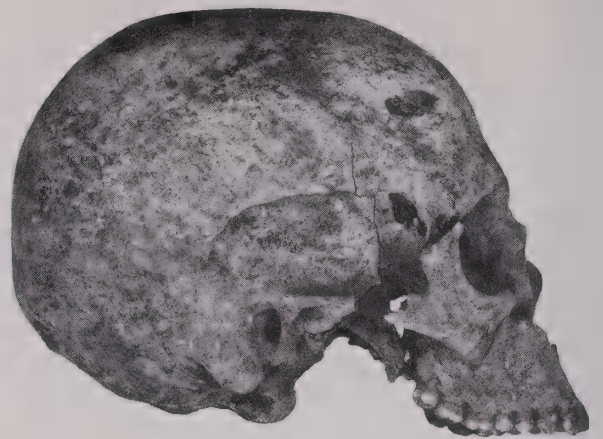

FIG. 197.—LB FEMALE SKULL (H 184) FROM TOMB 36 B. SCALE, 2:5

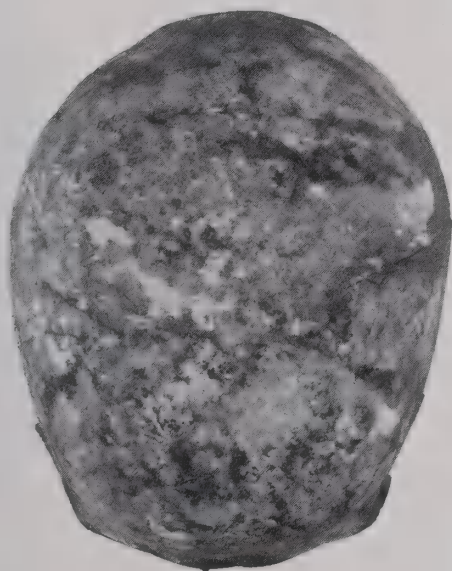
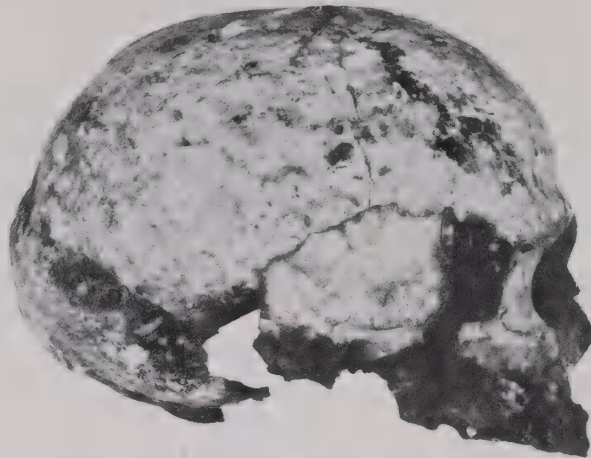
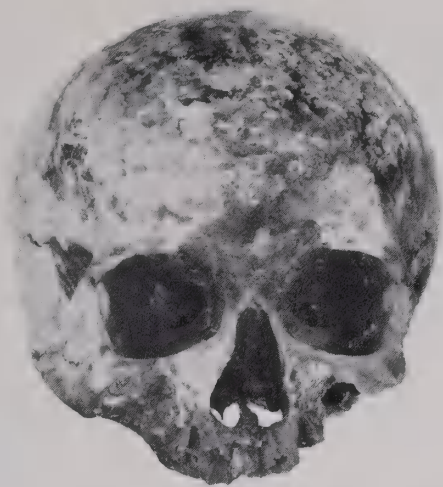

FIG. 198.—EI I MALE SKULL (H 163) FROM TOMB 1090 C. SCALE, 2:5



FIG. 199.—MI MALE SKULL (H 153) FROM TOMB 1265. SCALE, 2:5



FIG. 200.—LI OR CLASSICAL MALE SKULL (H 167) FROM TOMB 232 (SEE FIG. 161). SCALE, 2:5

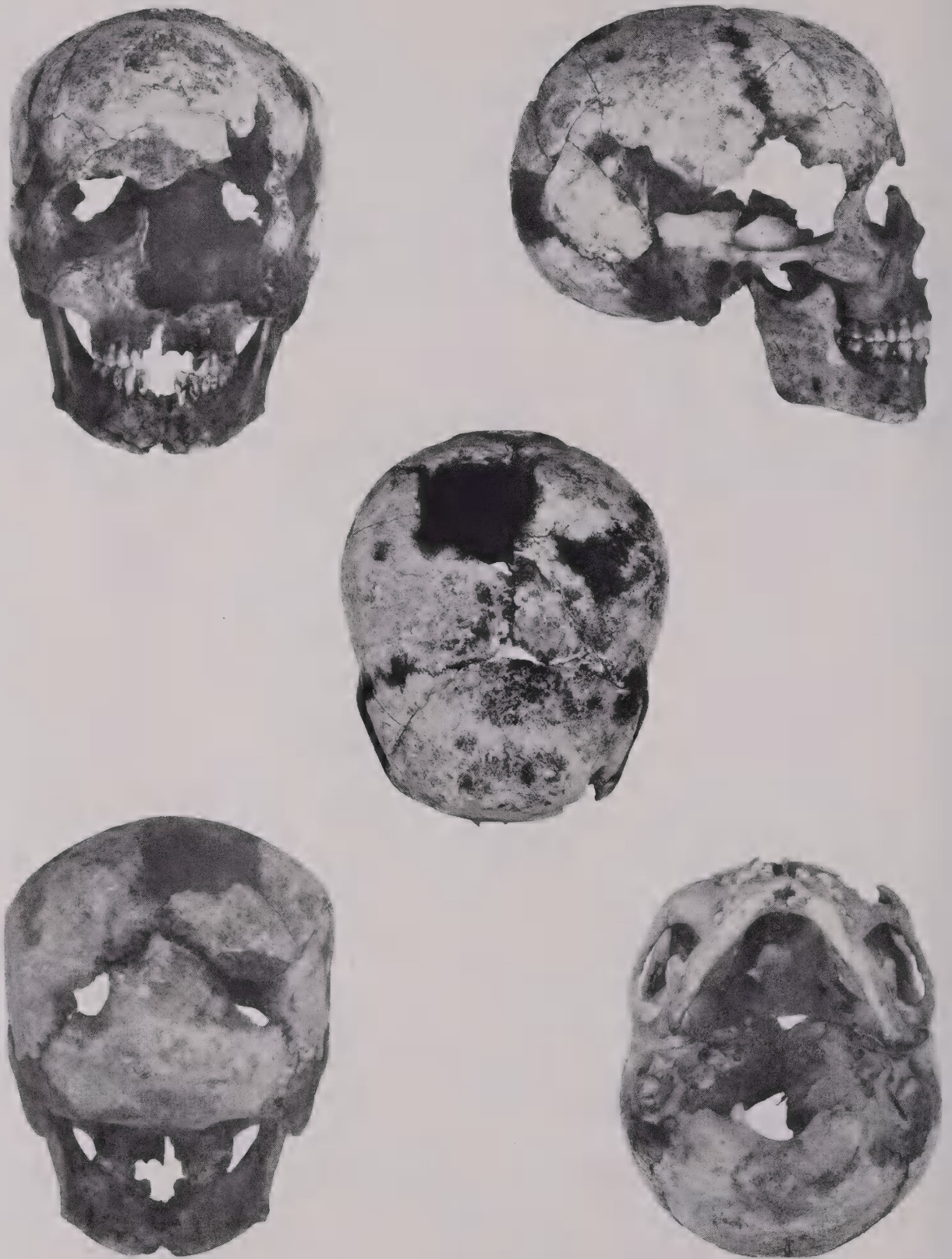
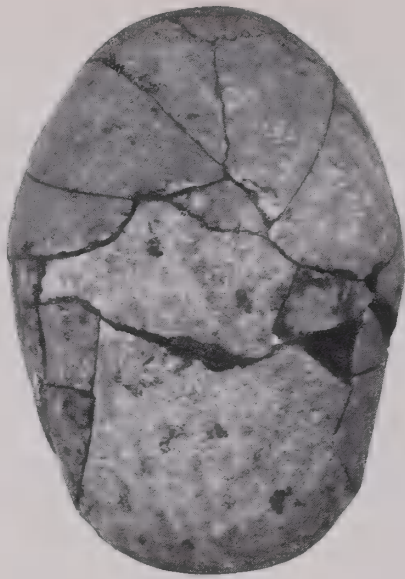

FIG. 201.—LI OR CLASSICAL FEMALE SKULL (H 168) FROM TOMB 232 (SEE FIGS. 161-62). SCALE, 2:5



FIG. 202.—LI OR CLASSICAL MALE SKULL (H 169) FROM TOMB 232 (SEE FIG. 162). SCALE, 2:5



1



2

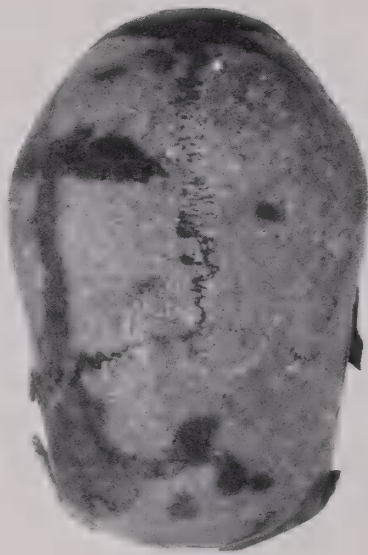

3



4

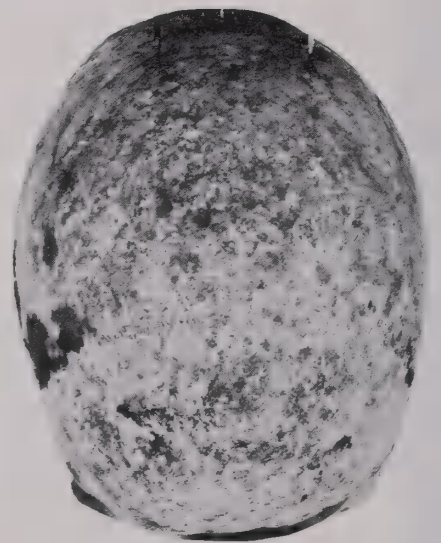

5

FIG. 203.—MISCELLANEOUS SKULLS. TOP VIEWS. SCALE, 2:5

- 1 = H 15 ♀ (T. 1103) Chalcolithic
- 2 = H 16 ♂ (T. 1103) Chalcolithic
- 3 = H 62 ♀ (T. 903 Upper) Chalcolithic
- 4 = H 121 ♂ (T. 911 A 1) MB II
- 5 = H 156 ♀ (T. 1276) MI

## VI

### ANIMAL REMAINS

By DOROTHEA M. A. BATE

Department of Geology, British Museum (Natural History)

The animal remains which form the subject of this report were obtained from tombs and occupation levels on the east slope of the tell. These loci were not all of one age but included what may be late Neolithic through Chalcolithic to LB II deposits.

These animal remains are fairly numerous, but, since most of the specimens are fragmentary, a detailed study of the specific characters or an elucidation of the relationship of the various forms is not yet possible.

In 1929 Dr. Max Hilzheimer published a description of the sacrificial remains of ox and goat from the MB site of Shechem,<sup>1</sup> and at Tell el-<sup>c</sup>Ajul in 1930 Sir Flinders Petrie discovered burials in which horse and other animal remains were associated with those of humans.<sup>2</sup> Apart from these records little seems to be known of the post-Neolithic animals of Palestine which were associated with Man.

Something is already known of the Pleistocene mammalian faunas of Palestine,<sup>3</sup> and it is hoped that a more complete account by the present writer will be published in 1937.<sup>3a</sup>

The fauna of Mesolithic times includes several species which are no longer found living in Palestine or in the neighboring countries. Among these are the spotted hyaena (*Crocuta crocuta*), which has been replaced by the very different striped hyaena (*Hyaena striata*), a large ox, and the red deer.<sup>4</sup>

The present collection gives no indication of a connection between the animals associated with Man in the Mesolithic and those in the Chalcolithic and EB periods. No doubt some of the wild fauna existed in the country throughout these times, but it is significant that three or four domesticated races which are represented in the Chalcolithic and EB deposits are unknown in the Mesolithic of Palestine, although the domestication of animals had then already begun. This naturally suggests that these later forms must have arrived in the country between Mesolithic and EB times, but it remains for future discoveries to supply more exact dating and details regarding the place of origin of these races.

<sup>1</sup> *Zeitschrift für Säugetierkunde* IV (Berlin, 1929/30) 125-28.

<sup>2</sup> *Gaza* I (1931) 4; II 5 and 14; IV 15.

<sup>3</sup> See D. M. A. Bate in F. Turville-Petre, *Researches in Prehistoric Galilee, 1925-26* (London, 1927) pp. 9-13 and 27-52, and in the *Annals and Magazine of Natural History* XIII, 10th series (London, 1934) pp. 120-29; Oscar Fraas, "Geologisches aus dem Libanon" (Verein für vaterländische Naturkunde in Württemberg, *Jahreshefte* XXXIV [1878]) 257-391; R. Vaufray in *L'Anthropologie* XLI (1931) 253-63; G. Zumoffen, *La Phénicie avant les Phéniciens: L'époque de la pierre* (Beyrouth, 1900).

<sup>3a</sup> Bate in D. A. E. Garrod and D. M. A. Bate, *The Stone Age of Mount Carmel* I (Oxford, 1937). Published since the above was written.

<sup>4</sup> D. M. A. Bate in *JRAI* LXII 277.

## LIST OF ANIMALS FOUND

Period	Remains	Locus
Neolithic?	Small ox	881 in square W 16
	Sheep or goat	
	Gazelle	
	Pig	
Chalcolithic	Small <i>Equus</i>	T. 903 and floors 1242 and 1199
	Small ox	
	Sheep or goat	
	Gazelle	
	Pig	
	Dog or jackal	
	Lion	
Bear		
Chalcolithic to EB	Small <i>Equus</i>	T. 910
	Small ox	
	Mamber goat	
	Large horned sheep	
	Pig	
MB I to LB II	Dog or jackal	Tombs 911-12, 989, 1100, 1145, and 1178
	Small <i>Equus</i>	
	Small ox	
	Sheep or goat	
	Pig	

## NOTES ON SOME OF THE SPECIES

*Equus* sp.

Remains of a small *Equus* were fairly plentiful in some of the deposits, notably in Tombs 903, 910, and 1100. Most of the specimens are too incomplete to admit of specific determination, but the majority of these represent a small animal which may have been either one of the *E. hemionus* group or a true ass. There is no evidence to prove whether or not this animal was domesticated.

Some limb bones from T. 903 are of considerable size and suggest the presence of a second species, possibly a true horse, *E. caballus*.

*Bos* cf. *longifrons*

A small ox was represented by the greatest number of specimens in the Neolithic(?), Chalcolithic, and EB deposits. Since no small wild cattle are known from the Near East, it seems certain that these remains must be those of a domesticated race. A considerable variation in size is noticeable, as in all domestic forms. A complete metacarpus from T. 903 has a length of 22 cm. and a width of 7.5 cm. at its distal articular end. The corresponding measurements of a metatarsus from the same deposit are 24 cm. and 6.5 cm.

Portions of several horn cores are preserved. The most complete one (Fig. 204) has a circumference of 14 cm. at the base.

## MAMBER GOAT

Remains of sheep or goat were present in all the deposits, but were generally fragmentary and not specifically determinable.

An interesting specimen obtained in T. 910 is the proximal portion of a twisted right horn core of a Mamber goat (Fig. 205). This is a domestic race said to have had its origin in Syria.<sup>5</sup>

<sup>5</sup> Since this report was written (1936) an interesting article by Prof. W. Amschler on evidence of a goat with twisted horns at Ur and Kish has appeared in *Antiquity* XI (1937) 226-28 and Pls. V-VI.

Its remains have frequently been found in tombs in Egypt, where it is shown in pictorial<sup>6</sup> representations also.<sup>7</sup> Dr. Claude Gaillard claims to have found its remains in the Neolithic site at Tukh, Upper Egypt.<sup>8</sup>

The Mamber goat must have been a widespread and well known race in the Near East. In 1898, during his travels east of Jebel ed-Druse, the late Sir Mark Sykes visited a remarkable deposit of bones at Heberieh, six hours by horseback northeast of Radaymah. Four hours' ride over a wilderness of black lava brought the travelers to an open space in the middle of

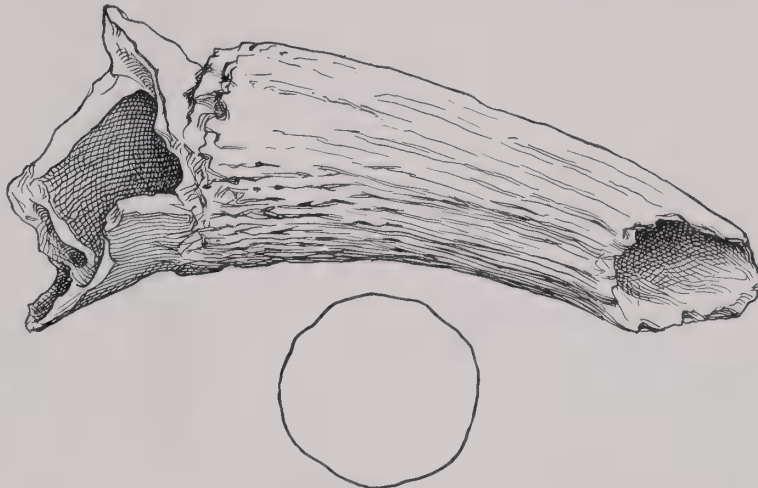

FIG. 204.—*Bos* cf. *longifrons*. PORTION OF LEFT HORN CORE, ANTERIOR VIEW AND TRANSVERSE SECTION. TWO-THIRDS NATURAL SIZE

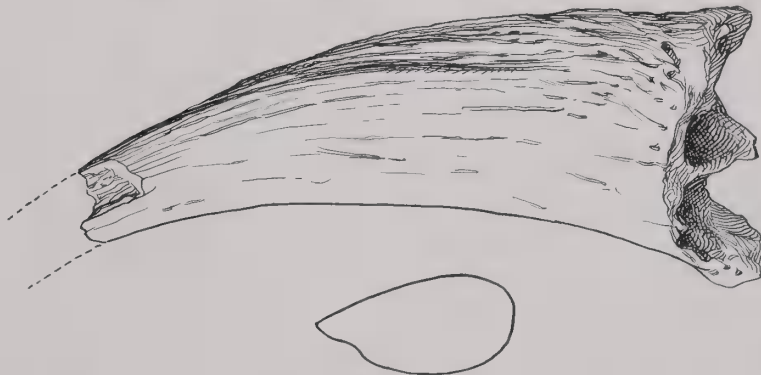

FIG. 205.—MAMBER GOAT. PORTION OF RIGHT HORN CORE, ANTERIOR VIEW AND TRANSVERSE SECTION. TWO-THIRDS NATURAL SIZE

which was a hill, three acres in extent and at least ten feet thick, of lava-cemented bones which must have represented the remains of millions of animals.<sup>9</sup> Some of the bones were submitted

<sup>6</sup> E.g. at Sakkarah; see L. C. Lortet and C. Gaillard, "La Faune momifiée de l'ancienne Égypte," pp. 107-10 in *Archives du Muséum d'histoire naturelle de Lyon* VIII (1903) "Mémoire" II and pp. 77-79 in *Archives ...* IX (1907) "Mémoire" II.

<sup>7</sup> [See e.g. Ludwig Borchardt in *ZAS* XXXVIII (1900) Pl. V and Richard Lepsius, *Denkmaeler aus Aegypten und Aethiopien* II, Pl. 9.—Ed.]

<sup>8</sup> "Contribution à l'étude de la Faune préhistorique de l'Égypte" (*Archives du Muséum d'histoire naturelle de Lyon* XIV [1934] "Mémoire" III) pp. 78-81.

<sup>9</sup> See *PEFQS*, 1899, pp. 54 f. For some of the details I am indebted to the late Professor A. E. Day, of the American University of Beirut, who received them direct from Sir Mark Sykes.

to the late Mr. E. T. Newton, who reported that there were "several 'horn-cores' belonging to a form of goat with spiral horns, and the limb bones accompanying these very probably belonged to the same species, which, it would seem, was of larger size than the common European goat, and may be a Syrian domestic animal."<sup>10</sup> This last remark is certainly justified, for I have before me a piece of horn core of Sir Mark Sykes's collection, sent to me by Professor Day, which is exactly similar to the specimen from Megiddo.

Since then Sir Robert Mond has brought home a few specimens which are evidently from the same locality. Sir Arthur Smith Woodward tells me that when he was at Ma'an a few years ago natives brought in some pieces of the bone bed. But these, like all the specimens I have seen, were fragmentary and, except for occasional pieces of horn cores, specifically indeterminate.

It has been suggested that this vast accumulation of animal bones represents a kitchen midden or a great sacrificial mound, but the final explanation, and also the important question

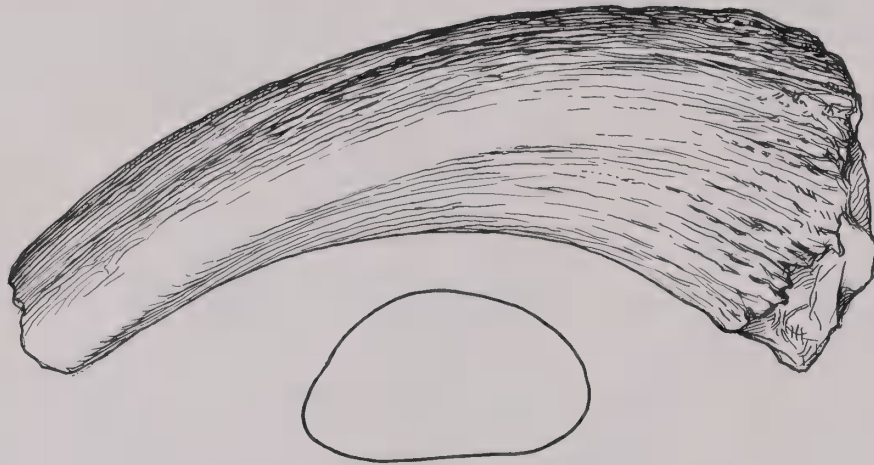

FIG. 206.—*Ovis* SP. LEFT HORN CORE, DORSAL VIEW AND TRANSVERSE SECTION. TWO-THIRDS NATURAL SIZE

of the exact dating, seem to await solution. The goat remains seem to have been accumulated prior to the lava flow and therefore suggest a very recent date for this volcanic activity.

*Ovis* SP.

A spiral horn core of a large sheep (Fig. 206) was obtained from T. 910. It has a maximum width of 6.3 cm. and a thickness of 4 cm. The ventral border is gently rounded, not keeled as in *Ovis vignei*. It differs in form from the horn cores of wild sheep, but resembles that of a Recent sheep which I have seen from a late deposit at Badari. It therefore may be presumed that the Megiddo horn core is that of a domestic race.

*Sus* SP.

Fragmentary remains of pig were found in nearly all the deposits, and their small size suggests that they represent a domestic race.

*Canis* SP.

Portions of skulls of a *Canis* about the size of a Recent jackal were found in T. 903 and T. 910. There seems to be some shortening of the skull and mandible, which suggests domestication; but more complete specimens are needed to decide this.

<sup>10</sup> *Ibid.* p. 56.

*Panthera leo*

The distal end of the humerus of a lion was found in T. 903 Upper, which I understand was a general burial hole; therefore the animal was not deliberately placed with a single human skeleton.

Lions survived in Palestine until a much later date than the Chalcolithic, as witness a number of references in Bible narratives.<sup>11</sup> Professor M. Boule has recorded that they occurred in Palestine up to the time of the Crusades.<sup>12</sup>

The mosaics found in the temple of Bacchus at Apamea, North Syria, are dated about 300 B.C. These include one which gives a realistic picture of a charging lion.<sup>13</sup> Dr. Bodenheimer has figured an animal mosaic from Tyre which includes a picture of a lion chasing a fallow deer.<sup>14</sup>

*Ursus arctos*

The brown bear is known from the same deposit (T. 903 Upper) as the lion and is also represented by a single imperfect humerus. This specimen resembles the corresponding bone of a Recent large bear from Syria in the British Museum collection.

<sup>11</sup> See H. B. Tristram, *The Natural History of the Bible* (9th ed.; London, 1898) p. 115.

<sup>12</sup> See *Annales de paléontologie* I (Paris, 1906) 92.

<sup>13</sup> Photograph published in the (London) *Times*, Dec. 31, 1932, p. 12.

<sup>14</sup> F. S. Bodenheimer, *Animal Life in Palestine* (Jerusalem, 1935) p. 115.



## INDEX OF TOMBS

Tomb No.	Page	Tomb No.	Page	Tomb No.	Page	Tomb No.	Page
1	100-101	40	106	219	87	911	64-68
2	101	41	29	221	121, 125	912	69-72
3	72	42	51	232	132	913	45
4	101	43-46	52	233	55	921	87
5	127	47	127	234	56	922	45
6	72	48	106	236	133	950	134
7	27	49-50	54	237	126	989	40
8	101	51	55	244	56	1014	47
9	20	52	20, 22	247	57	1090	126
11	116	53	55	251	57-59	1098	43
13	101, 103	56	55	252-54	59	1100	88-89
14	116	58	29	255	60	1101-2	24-27
15-16	29	59	106-8	257	60	1103	18
17	117	61-62	119	258	61	1106	22
18	72	63	108-11	644-45	61	1119-20	47
19	129-31	64	127	854	134	1122	18-20
20	72, 74	66	132	855-56	87	1126-27	12
21	74	67	29	857	134	1128	20
24	48-50	71-72	121	868	61	1141	94
25-26	103	73	111-13, 115	876	87	1145	94-99
27	127	75	82	877	33-36	1178	99-100
28	103	76	127	878	40-41	1250	116
29-30	117	77	82	880	40-41	1265	192
31	106	78	85	884	41-43	1276-77	192
36	106	79	29, 31	891	43-45	1291	192
37	74-81	80	127, 129	903	9-12		
38	82	84	115	907	132		
39	117-19	217	31	910	12, 17-18		



## INDEX OF SKELETON NUMBERS

Skeleton	Page etc.	Skeleton	Page etc.
H 1 (T. 1101 B Lower)	192, Figs. 26, 193	H 102 (T. 1100 A)	192, Figs. 109-10, Table VI
H 2 (T. 1101 B Lower)	192, Figs. 26, 194, Table VI	H 103 (T. 1100 A)	88, 192, Table VI
H 3-5 (T. 1101 B Lower)	192, Fig. 26	H 104 (T. 1100 A)	192, Figs. 110, 195, Table VI
H 6 (T. 1101 B Lower)	Fig. 26	H 105 (T. 1100 A)	88, 192
H 7-10 (T. 1101 B Lower)	192, Fig. 26	H 107 (T. 1100 A)	192, Figs. 108-9, Table VI
H 11-13 (T. 1101 B Lower)	Fig. 26	H 108 (T. 1100 A)	192, Fig. 108
H 14 (T. 1103)	192, Fig. 16, Table VI	H 109 (T. 1100 A)	192, Figs. 109-10, Table VI
H 15 (T. 1103)	192, Figs. 16, 203:1, Table VI	H 110 (T. 1100 A)	192, Fig. 196, Table VI
H 16 (T. 1103)	192, Figs. 16, 203:2, Table VI	H 111 (T. 1100 A)	88
H 17-18 (T. 1103)	Fig. 16	H 116 (T. 911 A1)	64-65, 192, Fig. 72, Table VI
H 23 (T. 1103)	192, Fig. 192, Table VI	H 121 (T. 911 A1)	192, Fig. 203:4, Table VI
H 24 (T. 1103)	192	H 130-31 (T. 1145 B)	95, Figs. 118-20
H 26 (T. 910 A)	192, Figs. 13, 191, Table VI	H 132 (T. 1145 B)	95, Figs. 119-20
H 27 (T. 910 A)	192, Fig. 13	H 133-38 (T. 1145 B)	95, Fig. 120
H 28 (T. 910 A)	Fig. 13	H 140 (T. 1141)	Fig. 113
H 31 (T. 910 B)	Fig. 187:1	H 141 (T. 1178)	99, Figs. 121, 187:6
H 33-39 (T. 903 Upper)	Fig. 4	H 142 (T. 1178)	99-100, Fig. 121
H 40 (T. 903 Upper)	192, Figs. 5, 189, Table VI	H 143 (T. 855)	87, Fig. 100
H 41-42 (T. 903 Upper)	Fig. 5	H 144 (T. 856)	87, Figs. 100, 187:7
H 43 (T. 903 Upper)	192, Fig. 5, Table VI	H 145 (T. 950)	134, 192, Table VI
H 44-45 (T. 903 Upper)	Fig. 5	H 153 (T. 1265)	192, Fig. 199
H 46 (T. 903 Upper)	192, Figs. 5, 190, Table VI	H 154 (T. 1277)	192, Table VI
H 47-50 (T. 903 Upper)	Fig. 5	H 155 (T. 1291)	192
H 51-52 (T. 903 Upper)	192, Fig. 5, Table VI	H 156 (T. 1276)	192, Fig. 203:5, Table VI
H 53-54 (T. 903 Upper)	192, Fig. 5	H 157 (T. 1276)	192
H 55-57 (T. 903 Upper)	Fig. 5	H 160 (T. 1090 C)	192, Fig. 155, Table VI
H 58 (T. 903 Upper)	192, Fig. 5, Table VI	H 161 (T. 1090 C)	192, Fig. 155
H 59-61 (T. 903 Upper)	Fig. 5	H 162 (T. 1090 C)	192, Fig. 155, Table VI
H 62 (T. 903 Upper)	192, Figs. 5, 203:3, Table VI	H 163 (T. 1090 C)	192, Fig. 198, Table VI
H 63 (T. 903 Upper)	192, Fig. 5, Table VI	H 167 (T. 232)	132, 192, Figs. 161, 200, Table VI
H 64-65 (T. 903 Upper)	Fig. 5	H 168 (T. 232)	132, 192, Figs. 161-62, 201
H 66 (T. 903 Upper)	192, Fig. 5, Table VI	H 169 (T. 232)	132, 192, Figs. 162, 202
H 67-69 (T. 903 Upper)	Fig. 5	H 173 (T. 921)	192, Fig. 103
H 70-71 (T. 903 Upper)	Figs. 5-6	H 179 (T. 25)	103, 192, Table VI
H 72 (T. 903 Upper)	192, Figs. 5-6, Table VI	H 180 (T. 25)	103, 192
H 73 (T. 903 Upper)	Fig. 5	H 181-83 (T. 36)	106, 192, Table VI
H 75-76 (T. 903 Upper)	Fig. 6	H 184 (T. 36)	106, 192, Fig. 197, Table VI
H 77 (T. 903 Upper)	192, Fig. 6, Table VI	H 185 (T. 36)	106, 192, Table VI
H 78 (T. 903 Upper)	192, Figs. 6, 188, Table VI	H 187 (T. 903 Upper)	Fig. 187:2
H 79-80 (T. 903 Upper)	192, Fig. 6	H 188 (T. 903 Upper)	Fig. 187:3
H 84-86 (locus 1184)	192	H 189 (T. 903 Upper)	Fig. 187:4
H 87 (T. 1127)	192, Figs. 8-9	H 190 (T. 903 Upper)	Fig. 187:5
H 88 (T. 1126)	192, Figs. 8, 10		



## GENERAL INDEX

In some instances references to plates are actually to material included in the descriptions opposite the plates instead of to objects illustrated on the plates.

- Abbott, Nabia, Pl. 171  
 Abiba'al, inscription of, p. 174  
 Abū Hawām, Tell (Palestine), pp. 111, 154, 157, 165, 168, 172, 177-78, 182, 184  
 Abu Yusef, p. x  
 Abū Zureik, Tell (Palestine), p. 144  
 Abydos (Egypt), pp. 145, 147  
 Adah, Tell (Syria), p. 148  
 adz head, "bronze," Pl. 90  
 adzes, p. 168  
 Aegean culture, pp. 153, 157, 160; *see also* Minoan and Mycenaean cultures  
 Aegean peoples, p. 158  
 Affūlah (Palestine), p. 144  
 Ahab, period of, p. 129  
 Ahiram, inscription of, pp. 174-76  
 Aḥmad ibn Ṭūlūn, p. 127, Pl. 171  
 Ain el-Kubbi (Palestine), p. 4  
 Ain Shems (Palestine), pp. 174-76  
 Ainsworth, William, & Sons (Denver, Colorado), p. 4  
 air-photographs, p. 2  
 Ajūl, Tell el- (Palestine), pp. 152, 164, 167-68, 173, 177-78, 188, 209  
 alabaster, *see* Egyptian "alabaster"  
 Albright, W. F., pp. x, 145-46, 149-50, 162  
 Aleppo (Syria), p. 151  
 Alexander, Christine, pp. 177, 189  
 Alishar (Anatolia), pp. 163, 168-69, 186  
 Allen, T. George, p. xi  
 Alpines, p. 192  
 Amārnah, Tell el-, pp. 4, 103, 155, 179; — letters, p. 162  
 Amenhotep I, time of, p. 185  
 Amenhotep III, p. 162  
 Amenhotep IV, p. 162  
 Amer, Mustapha, p. 144  
 American School of Oriental Research in Baghdad, p. 182  
 American University at Beirut, pp. 111, 211  
 amethyst beads, Pls. 136, 138, 147; — scarab, p. 185, Pl. 107; — scaraboids, Pl. 113  
 Amon, representation of, on scarab, Pl. 95:31  
 Amon-Re, name of, on scarabs, Pls. 100:8, 131:3, 165:7, 176:6  
 amulets, pp. 177-79; carnelian —, Pl. 157; fayence —, Pls. 94, 95, 115, 161, 165, 171, 173; pottery —, Pl. 163; silver —, Pl. 161; *see also* pendants  
 Anatolian culture, pp. 162-63, 165, 168-69, 186; *see also* Asia Minor  
 animal remains, pp. xi, 9, 12, 27, 40, 45, 59, 61, 67, 74, 89, 95, 99, 177, 209-13, Pl. 115:11  
 animals, representations of, pp. 177, 179, Pls. 156, 161, 165, 171-72, 176; *see also* amulets; figurines, animal; and pendants  
 Apamea (Syria), p. 213  
 ape amulets, p. 179  
 ape-back scarabs, p. 186  
 Arabic inscription on coin, Pl. 171  
 Aramaic inscriptions on Assyrian seals, p. 173  
 Armageddon (Megiddo, Tell el-Mutesellim), p. 1  
 Armenia, p. 162  
 armor scales, "bronze," Pl. 176  
 arrowheads, bronze, Pl. 167; "bronze" —, Pls. 89, 90, 107, 120, 123, 126, 135, 145, 153, 155-57, 167  
 As, Tell (Syria), p. 148  
 Asia, pp. 150, 153  
 Asia Minor, pp. 162-63  
 Asmar, Tell (Iraq), p. 162  
 ass remains, p. 210  
 Assur, p. 182  
 Assyrian culture, p. 152; *see also* Mesopotamian culture  
 Assyrian seals, p. 173  
 Assyroid facial features, p. 192  
 Astarte, representation of, Pl. 154:2  
 astragali, p. 177; model —, Pl. 115:24  
 Atshānah, Tell (Syria), p. 153  
 awls, bone, Pls. 110, 153, 155, 157  
 ax, miniature carnelian, Pl. 157:1  
 axheads, pp. 167-68; bronze —, Pl. 122; "bronze" —, Pls. 118, 133, 163  
 Babylonian culture, p. 165; *see also* Mesopotamian culture  
 Badari, pp. 144, 212  
 bail handle, iron, Pl. 161  
 Baker, G. W., Table II  
 basalt drill-sockets, Pls. 85, 135, 153; — grinders, p. 170, Pls. 76, 119, 135, 154, 173; — hammer-rubbers, Pls. 119, 158, 162; — maceheads or loom weights, Pls. 76, 85, 96, 174; — pestles, p. 170, Pls. 112, 154, 156, 164; — rubber-hammer, Pl. 162; — rubbers, Pls. 112, 130, 135-36, 154, 156, 173; — sockets, Pls. 121, 154, 157; — tournettes, Pls. 153, 164; unclassified — objects, Pls. 123, 156, 158, 173; — vessels, p. 186, Pls. 113-14, 123, 140-41, 153-54, 157, 162, 173, 175; — whetstone, Pl. 100  
 Bastet, basket of, Pl. 131:1  
 Bate, Dorothea M. A., p. xi  
 bathtub, pottery, p. 77  
 beads, pp. vii, 179-81, Pl. 161 (material unknown); amethyst —, Pls. 136, 138, 147; bone —, Pl. 152; "bronze" —, Pls. 136-38, 161; carnelian —, Pls. 68, 84, 95, 98, 100, 110, 132, 135-38, 147, 152, 157, 161, 165, 168, 171; chalcedony —, Pls. 135, 165; composition —, Pls. 110, 138, 161, 165, 171; diorite —, Pl. 168; fayence —, Pls. 90, 95, 100, 101, 110, 113, 115, 119, 121, 136-38, 145, 147, 157, 161, 165, 171, 174-75; glass —, Pls. 95, 96, 100, 110, 132, 135-36, 138, 148, 161, 165, 173; gold —, Pl. 132, 166, 168; jasper —, Pl. 161; limestone —, Pls. 101, 136; malachite —, Pl. 161; marble —, Pls. 135-36, 138; opal (hyalite) —, Pl. 152; pottery —, Pl. 89; quartz —, Pl. 132; serpentine —, Pls. 100, 132; shell —, Pls. 114, 135, 138, 145-46, 148, 171, 173; silver —, Pl. 132; stone —, Pl. 132  
 bear remains, pp. 210, 213  
 Beaumont, Ernest F., p. ix  
 Beisān (Palestine), pp. 111, 144-46, 155, 168, 182  
 Beit Mirsim, Tell (Palestine), pp. 55, 111, 147, 149-51, 168  
 Bes amulets, pp. 178-79, Pls. 94:5, 95:1-2, 165:14  
 Bible, references to lions in, p. 213  
 Billah, Tell (Iraq), pp. 153, 182-84  
 bird bones, Pls. 155, 157  
 Bittel, Kurt, p. 168  
 blades, "bronze," pp. 167-68, Pls. 89, 114; *see also* adzes, axheads, daggers, and knives  
 Bodenheimer, F. S., p. 213  
 Boghazköy (Anatolia), pp. 163, 168  
 Bolu (Anatolia), p. 168  
 bone awls, Pls. 110, 153, 155, 157; — beads, Pl. 152; — inlays, p. 186, Pls. 100, 113, 130, 145, 152-53, 166; — pin, Pl. 115; — spindles, pp. 170-72, Pls. 84, 95, 100, 156-58, 173; unclassified — objects, Pls. 76, 121; — whorls, p. 170, Pls. 84, 95, 98, 100, 114, 119, 132, 153, 157, 166, 171  
 borers, "bronze," Pls. 101, 107, 126; copper —, p. 137, Pl. 102  
 Boule, M., p. 213  
 Bowman, R. A., p. 173  
 boxes, ivory, Pls. 104, 142  
 bracelets, p. 177; "bronze" —, Pls. 127, 133, 135, 138, 161, 173; glass

- , Pl. 171; iron —, Pls. 137, 170; silver —, Pl. 145
- bread, preparation of, p. 25
- Breasted, James Henry, pp. xi, 1, 2
- Breasted, James Henry, Jr., p. ix
- British Museum, pp. xi, 188, 213
- bronze, pp. 7, 143, 153, 160–62; — arrowhead, Pl. 167; — axhead, Pl. 122; — daggers, Pls. 122, 133, 146; — knife, Pl. 120; — nail, Pl. 167; — spearheads, Pls. 122, 133, 146
- “bronze,” definition of, p. 6; — adz, Pl. 90; — armor scales, Pl. 176; — arrowheads, Pls. 89, 90, 107, 120, 123, 126, 135, 145, 153, 155–57, 167; — axheads, Pls. 118, 133, 163; — beads, Pls. 136–38, 161; — blades, pp. 167–68, Pls. 89, 114; — borers, Pls. 101, 107, 126; — bracelets, Pls. 127, 133, 135, 138, 161, 173; — buckles, Pls. 127, 157; — chains, Pl. 127; — chisels, Pls. 127, 145, 163, 163; — clasp, Pl. 126; — coin, Pl. 171; — daggers, Pls. 89, 96, 118, 125, 149, 154, 156, 158; — earrings, Pls. 128, 135, 161; — ear-stud, p. 177, Pl. 127; — figurine, Pl. 128; — hooks, Pls. 126, 157; — knives, Pls. 89, 90, 94, 119, 123, 125, 167; — nails, Pls. 89, 156, 167; — needles, Pls. 145, 148, 155, 175; — offering-stand, p. 188, Pl. 119; — peg, Pl. 138; — pins, Pls. 84, 94, 114–15, 120, 126, 136, 142, 145–46, 148, 150, 155, 168, 171; — plaques, Pls. 89, 148, 152; — rings, Pls. 95, 100, 105–6, 112, 120, 122, 128, 136, 145, 165–66, 169, 173; — scale-pans, Pls. 125, 167; — spear butt, Pl. 94; — spearheads, Pls. 118, 122, 125, 137, 145, 149, 163; — spoon, Pl. 126; — statuette, Pl. 153; — toggle pins, Pls. 89, 96, 103, 107, 113, 118, 126, 136, 145, 148, 150, 152, 167; — tongs, Pl. 125; — tweezers, Pls. 126, 176; unclassified — objects, Pls. 99, 126; — vessels, p. 188, Pls. 90, 119–20, 123–25, 133, 164, 168; — weights, Pl. 129
- Brunton, Guy, p. 185
- buckles, “bronze,” Pls. 127, 157
- Buisson, R. du Mesnil du, pp. 148, 162
- burial positions, pp. 135, 137–38, Table I
- burials in pottery vessels, pp. 137–38, Table I
- burnish, definition of, p. 6
- button, glass, Pl. 95; gold —, Pl. 145
- Byblos, pp. 89, 144, 147–49, 151, 164, 168, 173–76
- Cairo, p. 144
- Cameron, G. G., p. vii
- “Cappadocian” or “royal” sign, pp. 119, 163, Pl. 166
- Carmel Ridge, pp. 1, 24, 154
- carnelian, pp. 178–79, 185–86; — amulet, Pl. 157; — beads, Pls. 68, 84, 95, 98, 100, 110, 132, 135–38, 147, 152, 157, 161, 165, 168, 171; — pendants, Pls. 95, 96, 100, 132; — scaraboids, Pls. 95, 131; — scarabs, Pls. 100, 131
- Caucasus, pp. 162, 168
- cenotaph, pp. 56, 137
- chains, “bronze,” Pl. 127
- chalcedony beads, Pls. 135, 165
- Chatal Hüyük (Syria), p. 153
- chert hammers, Pls. 116, 162; — weights, Pl. 129
- Chiera, Edward, pp. x, 184, Pl. 90
- Child sacrifice, p. 57
- Childe, V. Gordon, p. 165
- chimney, p. 25
- chisels, “bronze,” Pls. 127, 145, 163
- Christian, V., p. 146
- chronology, pp. 7–8
- cisterns, pp. 18, 22, 41, 64, 68, 79, 80, 127
- clasp, “bronze,” Pl. 126
- cloth, p. 79, Pl. 138
- coin, “bronze,” Pl. 171; silver —, Pl. 171
- colors of antiquities, p. 6
- comb, ivory, Pl. 166
- comb-decorated pottery, p. 147
- composition (material), definition of, p. 6; — beads, Pls. 110, 138, 161, 165, 171; — cylinder seal, Pl. 90; — scarab, Pl. 176
- Concannon, T. A. L., p. ix
- copper, pp. 6, 143, 160–62; — borer, p. 137, Pl. 102; — daggers, Pls. 86, 122–23, 133; — kohl-stick, Pl. 86; — oxide stain on skull, p. 88; — pins, Pls. 101, 123; — ring, Pl. 86; — spearheads, Pls. 86, 120; — toggle pins, Pls. 86, 102; unclassified — object, Pl. 76
- cow figurines, Pls. 96:20, 128:13
- cow remains, pp. 9, 12
- crab, representation of, p. 156
- crater-shaped bowls, pp. 157–59
- crested pendant, pp. 177–78, Pl. 152; crescent-shaped dagger pommels, p. 165
- Crete, pp. 144, 149, 158, 164
- crocodile pendant, p. 179, Pl. 165:15
- Crowfoot, Mr. and Mrs. J. W., p. x
- Crusades, time of, p. 213
- cuneiform inscription, Pl. 90
- cupmarks, pp. 22, 103; *see also* pot-holes
- “cups and saucers,” pp. 5, 155, 159
- cylinder seals and impressions, pp. 145–47, 153, 182–84; composition or lapis lazuli —, Pl. 90; fayence —, Pls. 94, 95, 131, 152, 176; serpentine —, Pls. 95, 148
- Cypriote culture, pp. 151, 153–55, 158, 160, 165, 169, 182, 184; — ware, Pls. 11, 14, 16, 19, 20, 24, 30, 35, 38, 41–43, 45, 47–50, 55, 56, 59, 60, 62–64, 66, 67, 74, 135, 160
- dagger pommels, pp. 164–65; ivory —, Pl. 89; limestone —, Pls. 133, 146, 163, marble —, Pls. 118, 122, 149, 174
- daggers, pp. 164–65; bronze —, Pls. 122, 133, 146; “bronze” —, Pls. 89, 96, 118, 125, 149, 154, 156, 158; copper —, Pls. 86, 122–23, 133; iron —, Pls. 87, 158
- Damascus, p. 127
- Day, A. E., pp. 211–12
- Debevoise, N. C., p. vii, Pl. 171
- deer remains, p. 209
- DeLoach, Edward L., p. ix
- Delta of the Nile, p. 144
- descriptions of antiquities, pp. x, 6, 7
- designs on painted pottery, pp. 152–53, 156–57, 160
- dimensions of antiquities, p. 6; *see also* measurement
- diorite bead, Pl. 168; — vessel, p. 186, Pl. 140
- disk, ivory, Pl. 87; pottery —, Pl. 115
- Dnēbi (Syria), p. 148
- dog remains, pp. 210, 212
- domestic occupations, pp. 2, 7, 9, 17, 18, 20, 22, 24, 25, 27, 59, 74, 87, 101, 106, 111, 113, 127, 135, 145
- door socket, basalt, Pl. 121
- drain, pottery, Pl. 66
- drill-sockets, basalt, Pls. 85, 135, 153; gypsum —, Pl. 158; limestone —, Pls. 119, 141; *see also* sockets
- Drüse, Jebel ed- (Syria), p. 211
- duck-shaped toilet boxes, p. 188, Pls. 104, 142
- Dunand, Maurice, pp. x, 89, 174
- Duweir, Tell ed- (Palestine), pp. 149, 152, 156, 173, 175–76, 178–79
- Early Dynastic period (Mesopotamia), p. 145
- earrings, p. 177; “bronze” —, Pls. 128, 135, 161; electrum —, Pl. 95; gold —, Pls. 115, 119, 128, 166; silver —, Pls. 128, 167
- ear-stud, “bronze,” p. 177, Pl. 127
- Egypt, pp. 1, 158, 162, 211
- Egyptian “alabaster,” definition of, p. 6; — vessels, pp. 152, 186, 188, Pls. 87, 94, 107, 114, 119, 130, 135, 140–41, 145, 148, 172
- Egyptian culture, pp. 7, 103, 116, 129, 143–48, 150–55, 160, 162, 164–65, 168, 170, 178–79, 185–86, 188
- Egyptian hieroglyphic inscriptions on scarabs, p. 185, Pls. 95, 100, 105–6, 114–16, 119, 131, 137–38, 148, 152, 165, 176
- Egyptian language, p. 162
- Egyptian University, p. 144
- Elagabalus, p. 127, Pl. 171
- electrum earring, Pl. 95; — ring bezel, Pl. 120:10
- Eleusis (Greece), p. 186
- Engberg, M. J., Table II
- Engberg, R. M., pp. ix, x
- Esdraelon, Plain of, pp. 1, 154, 159
- Europe, p. 212
- European cultures, pp. 167, 170

- Fara, Tell (Palestine), pp. 55, 156, 168, 178, 186
- fayence, pp. 7, 185-86; — amulets, Pls. 94, 95, 115, 161, 165, 171, 173; — beads, Pls. 90, 95, 100, 101, 110, 113, 115, 119, 121, 136-38, 145, 147, 157, 161, 165, 171, 174-75; — cylinder seals, Pls. 94, 95, 131, 152, 176; — inlays, Pls. 132, 140; — pendants, Pls. 115, 121, 156; — scaraboids, Pls. 110, 131; — scarabs, Pls. 95, 119, 131, 165; — statuette, Pl. 174; unclassified — object, Pl. 130; — vessels, p. 188, Pls. 130, 168, 173
- feluccas, p. 7, Pls. 135-36, 138, 140, 154-56, 158
- figurines, animal, p. 9, Pls. 76, 85, 86, 96, 114, 128, 172; human —, p. 179, Pls. 89, 99, 107, 139, 153, 155, 163, 171, 174, 176; mold for —, Pl. 176
- fireplaces, pp. 24, 25; *see also* pot-holes
- fish-back scarab, p. 185, Pl. 100:8
- Fisher, Clarence S., pp. vii, ix, 2, 77
- Fisher, Stanley, p. ix
- FitzGerald, G. M., pp. x, 5, 144-45
- flint implements, p. 170, Pls. 68, 76, 79, 80, 83-85, 88, 89, 94, 98, 100, 101, 110, 112, 115-16, 120-21, 135, 142, 148, 150, 156, 158, 162, 169-71, 173-75; — weight, Pl. 168
- flue system in kiln, p. 77
- food, preparation of, p. 25
- foreign relationships, Table V; *see also* Aegean, Anatolian, Cypriote, Egyptian, Mesopotamian, Minoan, Mycenaean, and Syrian cultures
- fossil gastropod, p. 179, Pl. 173
- Frankfort, Henri, pp. x, 144, 146, 168
- funnels, pottery, pp. 106, 155, Pls. 13, 16, 35, 37, 54, 60, 93, 156
- Gad, William Effendi, p. ix
- Gaillard, Claude, p. 211
- gaming-pieces, ivory, Pl. 161; limestone —, Pl. 132; pottery —, Pl. 90
- Garrod, Dorothy, pp. x, 24
- Garstang, John, p. 145
- gastropod, Pl. 173
- Gauthier, H., Pl. 106:4
- Gâvurkalesi (Anatolia), p. 168
- Gaza (Palestine), p. 151
- gazelle remains, p. 210
- Gelb, I. J., p. vii
- Gerar (Palestine), p. 129
- German Hospital in Haifa, p. x
- Gezer (Palestine), pp. 115, 150-53, 156, 182, 184
- Ghassulian culture, p. 145
- Ghurāb (Egypt), p. 185
- Gjerstad, Einar, pp. 151, 153-54
- glass, pp. 52, 177, 179-80, 186; — beads, Pls. 95, 96, 100, 110, 132, 135-36, 138, 148, 161, 165, 173; — bracelet, Pl. 171; — button, Pl. 95; — inlay, Pl. 132; — knob, Pl. 156; — pendants, Pl. 175; — ring setting, p. 173, Pl. 175:12; — scarab, Pl. 165; unclassified — object, p. 132; — vessels, p. 189, Pl. 175
- Glueck, Nelson, p. x
- goat remains, pp. 95, 99, 209-12
- gold beads, Pls. 132, 166, 168; — button, Pl. 145; — earrings, Pls. 115, 119, 128, 166; — medallion, p. 163, Pl. 166; — pendant, Pl. 166; — rings, Pls. 128, 165-66, 175; — toggle pins, Pl. 168; unclassified — object, Pl. 166
- gold foil plaques, Pls. 128, 165, 168; unclassified — objects, Pls. 95, 120, 168
- gold plating, p. 162
- goldwork, p. 173
- Gournia (Crete), p. 149
- grain measures, p. 12
- grain-washing on pottery, p. 143
- granite rubber, Pl. 135
- grape-cluster pendants, pp. 178-79, Pl. 156
- gray burnished ware, pp. 143-45, 186
- Greece, pp. 157, 186
- Greek inscription on coin, Pl. 171
- Greek lamps, p. 127, Pls. 74, 172
- Grimme, Hubert, p. 176
- grinders, basalt, p. 170, Pls. 76, 119, 135, 154, 173
- Gurley, W. & L. E. (Troy, N. Y.), p. 4
- gypsum drill-socket, Pl. 158
- Guy, P. L. O., pp. 144, 149, 188
- Haifā (Palestine), pp. x, 1, 4, 111, 154 halberd, p. 168
- Ḥamāh (Syria), p. 144
- Hamid, Hamid Ahmed, p. x
- Hamilton, R. W., pp. ix, 111, 168
- hammer-rubbers, p. 7; basalt —, Pls. 119, 158, 162
- hammers, pp. 7, 170; basalt —, Pl. 162; chert —, Pls. 116, 162; limestone —, Pls. 116, 161-62
- Handakūḫ, Tell (Transjordan), p. 144
- handle, iron, Pl. 161
- handles on pottery, pp. 150, 159; *see also* ledge handles
- Ḥasī, Tell el- (Palestine), p. 152
- Hassan, Hassan Effendi, p. ix
- Hathor, horns of, Pl. 131:1
- Hauser, A. R., p. vii
- Hauser, Elizabeth, p. vii
- hearths, *see* fireplaces
- Heberieh (Syria), p. 211
- Hebrew language, p. 176
- Hellenistic pottery, Pl. 42:31
- hematite figurine, Pl. 128; — rubber, Pl. 130; — weights, Pls. 129, 168
- Higgins, Daniel F., p. ix
- Hilzheimer, Max, p. 209
- Hittite culture, pp. 152, 163, 168-70, 186
- Hittites, pp. 158, 162
- Hoffman, Dr., p. x
- holes in tomb walls and floors, pp. 33, 40, 43, 47, 48, 67, 89, 137-38; objects found in —, pp. 47, 89, 137-38, Pls. 120, 122, 149
- hooks, "bronze," Pls. 126, 157
- horse remains, pp. 209-10
- Horsfield, George, and wife, p. x
- Hrdlička, Aleš, p. xi
- Horus, representation of, Pl. 165:6
- Hubert, Henri, p. 168
- Hucklesby, C. M., p. ix
- human skeletal remains, chap. v
- "Hurrian" motifs on pottery, pp. 151, 153-54, 182, 184
- hyaena remains, p. 209
- hyalite, *see* opal
- Hyksos deposits, pp. 50, 55, 81, 119, 148-53, 161, 164, 167-68, 170, 184-86, Pls. 95, 105-6, 137, 165, 167, 176
- Ialysos (Rhodes), pp. 165, 188
- illustrations of antiquities, pp. vii, ix, x, 4, 5
- imitations of foreign wares, pp. 36, 113, 115, 155, 157-58, Table V; *see also* foreign relationships
- imports, Table V; *see also* foreign relationships
- inlays, p. 186; bone —, Pls. 100, 113, 130, 145, 152-53, 166; fayence —, Pls. 132, 140; glass —, Pl. 132; ivory —, Pls. 108-9, 111, 166, 172
- Ionic volute, p. 186
- inscriptions, *see* Arabic, cuneiform, Egyptian hieroglyphic, Greek, Old Canaanite
- Iraq, *see* Mesopotamian culture
- iron, pp. 162-63; — bail handle, Pl. 161; — bracelets, Pls. 137, 170; — daggers, Pls. 87, 158; — knife, Pl. 167; — rings, Pls. 128, 166; — sickle, Pl. 136; — wedge, Pl. 139
- Irwin, W. A., p. 173
- Isis, representation of, Pl. 131:9
- Itayim, W., Table II
- ivory boxes, Pls. 104, 142; — comb, Pl. 166; — dagger pommel, Pl. 89; — disk, Pl. 87; — gaming-piece, Pl. 161; — inlays, Pls. 108-9, 111, 166, 172; — kohl-stick, Pl. 175; — spoon, Pl. 168; unclassified — object, Pl. 166; — vessels, p. 188; — whorls, Pl. 95
- jackal remains, pp. 210, 212
- jasper bead, Pl. 161; — scarab, p. 185, Pl. 106
- Jemdet Naṣr period, pp. 145-46
- Jenin (Palestine), p. 116
- Jericho, pp. 144-45, 147, 151, 164, 167
- Jerusalem, pp. x, 131
- Jordan Valley, p. 144
- Judaidah, Tell el- (Syria), p. 153
- Judea, p. 1
- Kadesh (Syria), p. 158
- Kamare Cave (Crete), p. 149
- Kent, Charles, p. ix
- Khafājah (Iraq), p. 162
- Khān Sheikhūn (Syria), p. 148

- Khepri, representation of, Pls. 131:9, 165:13
- Khirbet Kerak ware, pp. 20, 147, Pl. 10:1
- "killed" objects, pp. 26, 67, 68, 89, 101, 137-38, Pls. 87, 90, 118, 122, 149, 153, 166; *see also* holes in tomb walls and floors
- kilns, pp. 27, 77, 81, 82, 103
- Kirkuk style cylinder seals, pp. 182-84
- Kish, p. 210
- Kishon Pass, p. 154
- kitchen midden, p. 212
- knives, p. 165; bronze —, Pl. 120; "bronze" —, Pls. 89, 90, 94, 119, 123, 125, 167; iron —, Pl. 167; *see also* daggers
- knob, glass, Pl. 156
- Knossos (Crete), p. 158
- kohl-stick, copper, Pl. 86; ivory —, Pl. 175
- kohl tube, glass, Pl. 175
- Kosseiri, Ali el-, p. x
- Kültepe (Anatolia), pp. 163, 168
- Lacheman, E. R., Pl. 90
- Lamon, Robert S., p. ix
- lapis lazuli cylinder seal, Pl. 90
- lead weight, Pl. 168
- ledge handles, pp. 36, 143-49
- levels, pp. 4, 5
- limestone beads, Pls. 101, 136; — dagger pommels, Pls. 133, 146, 163; — drill-sockets, Pls. 119, 141; — gaming-pieces, Pl. 132; — hammers, Pls. 116, 161-62; — palette, Pl. 163; — rubber-hammers, Pls. 162, 173; — rubbers, Pls. 76, 135, 154, 162; — tournette, Pl. 158; unclassified — object, Pl. 76; — vessel, Pl. 83; — weights, Pls. 157, 161, 168; — whorls, Pls. 85, 157
- Lind, Olaf E., pp. ix, x
- lion remains, pp. 210, 213
- Little, Charles, p. ix
- locus, pp. 4, 5, 7
- loom weights, mud, Pl. 152; pottery —, Pl. 145; *see also* maceheads or loom weights
- lotus seed-vessels, carnelian, p. 178, Pls. 95, 96, 100, 132
- Lucas, A., p. 162
- Ma-ādī, el- (Egypt), p. 144
- Ma'an (Transjordan), p. 212
- Macalister, R. A. S., p. 152
- maceheads or loom weights, basalt, Pls. 76, 85, 96, 174
- Mackay, Ernest, p. x
- Mahmoud, p. x
- malachite bead, Pl. 161
- Mallon, Alexis, p. x
- Malta, p. 144
- Mamber goat, pp. 210-12
- Mantah, Tell (Transjordan), p. 144
- marble beads, Pls. 135-36, 138; — dagger pommels, Pls. 118, 122, 149, 174; — rubber, Pl. 135
- Marduk, p. 184, Pl. 90:8
- May, Herbert G., pp. ix, x
- measurement, definition of, p. 5; *see also* dimensions of antiquities
- medallion, gold, p. 163, Pl. 166
- Mediterranean physical type, p. 192
- Melia (Cyprus), p. 154
- Menghin, Oswald, p. 144
- Merenptah, time of, p. 158
- Mesnil du Buisson, R. du, pp. 148, 162
- Mesolithic period, p. 209
- Mesopotamia, p. 1
- Mesopotamian culture, pp. 144-47, 152-53, 162, 165, 168-69, 173, 182-84
- metal analyses, pp. 7, 9, 143, 160-62, Table II
- Metropolitan Museum of Art, pp. 177, 189
- Minet el-Beidā (Syria), pp. 111, 153, 155, 165, 188
- Minoan culture, pp. 144, 149, 158, 164
- Mishrifé, el- (ancient Qaṭna, Syria), p. 148, 162, 164, 168
- Mitanni, p. 162
- Mochlos (Crete), pp. 149, 164
- Möller, Georg, p. 165
- mold for female head, Pl. 176
- Mond, Sir Robert, p. 212
- Morgan, W. R., p. 179
- mouthpieces, *see* plaques
- mud loom weight, Pl. 162
- Mughāret el-Wādī (Palestine), p. 24
- mummification, pp. 67, 138
- Mut amulet, Pl. 173:3
- Mutesellim, Tell el- (Armageddon, Megiddo), p. 1
- mutilated objects, *see* "killed" objects
- Mycenaean culture, pp. 111, 154, 157-58, 160, 188; — ware, Pls. 14, 17, 32, 34, 35, 56, 62, 64, 75, 124
- nails, bronze, Pl. 167; "bronze" —, Pls. 89, 156, 167
- Naḳādah II, p. 143
- Natufian period, p. 24
- needles, "bronze," Pls. 145, 148, 155, 175
- Neferhotep II, name of, Pl. 106:4
- "Nehebkau," representation of, Pl. 171:18
- Negro, representation of, Pl. 174:12
- Negroid facial features, p. 192
- Nelson, Harold H., pp. x, 1
- Neolithic period, pp. 144, 209-11
- Nephthys, representation of, Pl. 131:9
- Newton, T. E., p. 212
- Nin-Egal, p. 162
- numbers, field and registration, pp. vii, 4
- Nuzi type cylinder seals, pp. 153, 182-84
- offering-place, p. 56
- offering-stand, "bronze," p. 188, Pl. 119
- ointment spoon, Pl. 168
- Old Canaanite script, pp. 173-76, Pl. 128:15
- olives, p. 134
- Olmstead, A. T., p. vii
- Omri, period of, p. 129
- opal (hyalite) bead, Pl. 152
- ossuaries, p. 135, Table I
- Osten, H. H. von der, pp. 163, 169, Pl. 176
- ovens, pp. 61, 77; *see also* fireplaces and pot-holes
- ox remains, pp. 209-10
- painted pottery, pp. 146, 150-52, 154, 156-57, 160
- Palestine Government, pp. x, 5, 116, Table II
- palette, limestone, Pl. 163
- Parker, Ralph B., pp. ix, x
- Parmelee, C. W., p. 179
- peg, "bronze," Pl. 138
- Peloponnesus, p. 157
- pendants, pp. 177-79; carnelian —, Pls. 95, 96, 100, 132; fayence —, Pls. 115, 121, 156; fossil —, Pl. 173; glass —, Pl. 175; gold —, Pl. 166; silver —, Pl. 152; *see also* amulets
- Pendlebury, J. D. S., pp. x, 111
- Perkins, Ann L., p. vii
- Persia, p. 162
- Persson, Axel W., p. 162
- pestles, basalt, p. 170, Pls. 112, 154, 156, 164
- Petrie, Sir Flinders, pp. x, 111, 115, 144, 165, 168, 178-79, 209, Pls. 95, 105:10
- pets, p. 100
- Philistine culture, pp. 115, 157-59, 162; — ware, Pls. 8:22, 37: x 119
- Phillips, Dudley W., p. xi
- Phoenicia, p. 1
- Phoenician inscriptions, pp. 173-76
- Phrygian deposits, p. 168
- Phythian-Adams, W. J., pp. x, 157-58
- Piepkorn, Arthur C., p. ix
- pig (sow) amulet, p. 179, Pl. 161:2; — remains, pp. 210, 212
- pins, bone, Pl. 115; "bronze" —, Pls. 84, 94, 114-15, 120, 126, 136, 142, 145-46, 148, 150, 155, 168, 171; copper —, Pls. 101, 123
- pits in tomb floors, pp. 18, 22, 41, 64, 68, 72, 74, 82, 106, 110, 125, 127
- plaques, "bronze," Pls. 89, 148, 152; gold foil —, Pls. 128, 165, 168; silver —, Pls. 119-20
- plastron, Pl. 150
- Pleistocene period, p. 209
- polish on pottery, definition of, p. 6
- pomegranate pendants, p. 179, Pl. 166:9
- pot-holes, pp. 20, 22, 24, 27, 135
- pottery amulet, Pl. 163; — bathtub, p. 77; — bead, Pl. 89; — disk, Pl. 115; — drain, Pl. 66; — figurines, p. 179, Pls. 76, 85, 86, 89, 96, 99,

- 107, 114, 139, 155, 163, 171-72, 176;  
— funnels, pp. 106, 155, Pls. 13, 16,  
35, 37, 54, 60, 93, 156; — gaming-  
piece, Pl. 90; — loom weight, Pl.  
145; — marks, p. 12; — ring bezel,  
Pl. 93; — smelting-brazier, Pl. 12;  
— stars, Pls. 85, 154; unclassified  
— objects, Pls. 4, 60, 63, 138, 156,  
158, 161; — wheel, Pl. 85; — whorls,  
Pls. 88, 110, 112, 142, 153, 161, 163
- Prost, Claude, p. x
- Ptah, representation of, Pl. 131:1 and  
3; name of —, Pl. 165:11
- Ptah-Sokar, representation of, p. 179,  
Pl. 165:13
- Qaṭna, *see* el-Mishrifé
- quartz, definition of, p. 7; — bead, Pl.  
132; — scarab, Pl. 131
- Raḍaymah (Syria), p. 211
- Ramses II, p. 162, Pl. 131:3 and 10;  
name of —, p. 185, Pls. 95:31, 100:  
5; time of —, pp. 40, 157-58, 176,  
182
- Ramses III, time of, p. 158
- Ranke, Hermann, p. x
- Ras Shamra, pp. 111, 151, 153, 164,  
168
- Re, representation of, Pl. 131:6
- Recent period, pp. 212-13
- Reshef statuette, p. 101, Pl. 153
- Rhodes, pp. 144, 165, 188
- ring bezel, pottery, Pl. 93
- rings, pp. 173-76; "bronze" —, Pls.  
95, 100, 105-6, 112, 120, 122, 128,  
136, 145, 165-66, 169, 173; copper  
—, Pl. 86; gold —, Pls. 128, 165-66,  
175; iron —, Pls. 128, 166; silver —,  
Pls. 107, 163
- Rockefeller, John D., Jr., pp. 1, 2
- Roman deposits, pp. 127, 129-32, 177,  
186, 189, Pls. 171-72, 175
- Romig, W. W., p. vii
- Rowe, Alan, p. x, Pl. 131:3
- "royal" or "Cappadocian" sign, pp.  
119, 163, Pl. 166
- rubber-hammers, pp. 7, 170; basalt  
—, Pl. 162; limestone —, Pls. 162,  
173
- rubbers, pp. 7, 170; basalt —, Pls.  
112, 130, 135-36, 154, 156, 173;  
granite —, Pl. 135; hematite —,  
Pl. 130; limestone —, Pls. 76, 135,  
154, 162; marble —, Pl. 135
- sacred eye, Egyptian, p. 178, Pl. 95
- sacrifice, child, p. 57
- Šāfi, Tell es- (Palestine), p. 188
- Šakḳārah (Egypt), p. 211
- Salameh, p. x
- Samaria, pp. 129, 186
- Samsun (Anatolia), p. 168
- sandstone whetstone, Pl. 130
- Šarafand (Syria), p. 111
- scale-pans, "bronze," Pls. 125, 167
- scales, Pl. 127:6
- scaraboids, pp. 184-86; amethyst —,  
Pl. 113; carnelian —, Pls. 95, 131;  
fayence —, Pls. 110, 131; steatite  
—, Pls. 100, 107, 137, 152, 165
- scarabs, pp. xi, 150, 153, 157, 173,  
184-86; amethyst —, Pl. 107;  
carnelian —, Pls. 100, 131; composi-  
tion —, Pl. 176; fayence —, Pls.  
95, 119, 131, 165; glass —, Pl. 165;  
green jasper —, Pl. 106; quartz —,  
Pl. 131; steatite —, Pls. 95, 100,  
105-6, 110, 113-16, 131, 137-38,  
148, 152, 165, 176
- Schaeffer, C. F. A., pp. x, 111
- Scheil, V., p. 183
- Schumacher, G., pp. 2, 132, 134, 156-  
57, 188
- "Sea Peoples," p. 158
- seals, *see* cylinder seals and stamp  
seals
- Sebek, representation of, Pl. 131:9
- Sedment (Egypt), pp. 152, 154
- seeds, p. 134
- Seele, Keith C., p. 179
- Sekhanre, name of, Pl. 105:2
- Sekhmet, representation of, p. 178,  
Pls. 95:3, 131:1, 173:3
- Semite, representation of, Pl. 174
- Semitic languages, pp. 173-76
- serpentine bead, Pls. 100, 132; —  
cylinder seals, Pls. 95, 148; —  
weights, Pl. 168; — whorls, Pls.  
157, 166
- Sesostris I, name of, Pl. 105:13
- Sesostris II, name of, Pl. 116:8
- Set, representation of, Pl. 165:6
- shaft tombs, pp. 135-37, 149, Table I
- Sharon, p. 1
- shaving of pottery, p. 155
- Shechem (Palestine), p. 209
- sheep figurines, Pls. 86:7, 128:12 and  
14; — remains, pp. 59, 61, 74, 95,  
99, 210, 212, Pl. 115:11
- shell beads, Pls. 114, 135, 138, 145-  
46, 148, 171, 173
- shells, Pls. 76, 94, 123, 130, 161, 166,  
170, 174
- Shephelah, p. 156
- Sheshonk I, time of, p. 129
- Shipton, Geoffrey M., pp. ix, x, 145,  
149
- Siamon, name of, Pl. 131:10
- sickle, iron, Pl. 136
- Sidon, p. 111
- silver amulet, Pl. 161; — bead, Pl.  
132; — bracelet, Pl. 145; — coin,  
Pl. 171; — earrings, Pls. 128, 167;  
— pendant, Pl. 152; — plaques,  
Pls. 119-20; — rings, Pls. 107, 163;  
— toggle pins, Pls. 107, 136, 168; —  
wire, Pl. 132
- Sinaitic inscriptions, pp. 173-76
- slate whorls, Pls. 154, 171; — weight,  
Pl. 168
- slip on pottery, definition of, p. 6
- smelting-brazier, pottery, Pl. 12
- Smith, Sir George Adam, p. 1
- sockets, basalt, Pls. 121, 154, 157;  
stone —, p. 80; *see also* drill-sockets
- Sorial, Labib Effendi, p. ix
- spear butt, "bronze," Pl. 94
- spearheads, pp. 163-64; bronze —,  
Pls. 122, 133, 146; "bronze" —, Pls.  
118, 122, 125, 137, 145, 149, 163;  
copper —, Pls. 86, 120
- Speiser, E. A., pp. 153, 182
- spindles, bone, pp. 170-72, Pls. 84,  
95, 100, 156-58, 173
- spoon, "bronze," Pl. 126; ivory —,  
Pl. 168
- square, definition of, p. 5
- stairs in tombs, pp. 47, 94, 110, 121,  
126, 135, 138
- stamp seals, p. 148
- Stanley, W. F., & Co. (London), pp.  
4, 5
- Staples, William E., pp. ix, x
- Starkey, J. L., p. x
- Starrett, L. C., Co. (Athol, Massa-  
chusetts), p. 5
- stars, pottery, Pls. 85, 154
- state of preservation of antiquities,  
p. 5
- statues, Egyptian, p. 150
- statuette, "bronze," Pl. 153; fayence  
—, Pl. 174
- steatite, pp. 185-86; — scaraboids,  
Pls. 100, 107, 137, 152, 165; —  
scarabs, Pls. 95, 100, 105-6, 110, 113-  
16, 131, 137-38, 148, 152, 165, 176;  
— whorls, Pls. 84, 98, 100, 119, 132
- Stein, Sir Aurel, p. x
- stone, *see* basalt, diorite, granite,  
gypsum, hematite, limestone, sand-  
stone, serpentine, and steatite;  
— bead, Pl. 132; — socket, p. 80
- Stone Age, p. 145
- storage pits, *see* pits in tomb floors
- stratum, definition of, p. 5
- Sukenik, E. L., p. x
- Sumer, p. 162
- Sykes, Sir Mark, pp. 211-12
- Syria, pp. 1, 210, 212-13
- Syrian culture, pp. 29, 36, 89, 111,  
144, 147-49, 151-55, 158, 162, 164-  
65, 168, 170, 173-76, 186, 188-89
- Syro-Hittite art, p. 152
- Ta'annak, Tell (Palestine), pp. 152,  
156
- Tchoub, Serge, p. x
- "teapots," pp. 29, 36, 47, 148-49
- Tell . . . , *see* . . . , Tell
- Tepe Gawrā (Iraq), p. 146
- Terentieff, J., p. ix
- terminology, inconsistency of, pp. 7-8
- Thoth ape, representation of, p. 179,  
Pl. 165:13
- thunderbolt symbol, p. 163
- Thutmose III, p. 153; name of —, p.  
185, Pls. 131:4, 165:1; time of —,  
p. 185
- tin, pp. 160-62
- toggle pins, pp. 168-70; "bronze" —,  
Pls. 89, 96, 103, 107, 113, 118, 126,  
136, 145, 148, 150, 152, 167; copper

- , Pls. 86, 102; gold —, Pl. 168;  
silver —, Pls. 107, 136, 168
- toilet boxes, ivory, p. 188, Pls. 104,  
142
- tomb types, summary of, Table I
- tongs, "bronze," Pl. 125
- tool marks, pp. 12, 17, 31, 47, 64, 72,  
88, 101, 115, 137
- tournette sockets, basalt, Pls. 121,  
154, 157
- tournettes, basalt, Pls. 153, 164; lime-  
stone —, Pl. 158
- Transjordan, pp. 122, 144
- tree-of-life pattern, pp. 152, 156-57,  
160
- Troy, pp. 165, 168, 186
- Ṭūkh (Egypt), p. 211
- Turkey, *see* Anatolia
- turtle (plastron) remains, Pl. 150
- Tushratta, p. 162
- Tut-ankhamon, tomb of, p. 162
- tweezers, "bronze," Pls. 126, 176
- Tyre, pp. 111, 213
- United States Consulate-General in  
Jerusalem, p. x
- United States National Museum, p.  
xi
- University of Illinois, p. 179
- Ur, pp. 162, 165, 210
- Uruk period, pp. 144, 146
- ventilation, p. 20
- vessels, basalt, p. 186, Pls. 113-14,  
123, 140-41, 153-54, 157, 162, 173,  
175; "bronze" —, p. 188, Pls. 90,  
119-20, 123-25, 133, 164, 168;  
burials in pottery —, pp. 137-38,  
Table I; diorite —, p. 186, Pl. 140;  
Egyptian "alabaster" —, pp. 152,  
186, 188, Pls. 87, 94, 107, 114, 119,  
130, 135, 140-41, 145, 148, 172;  
fayence —, p. 188, Pls. 130, 168,  
173; glass —, p. 189, Pl. 175; ivory  
—, p. 188, Pls. 104, 142; limestone  
—, Pl. 83; zoomorphic —, Pl. 156
- Vincent, Hugues, p. x
- Violleaud, Charles, p. 162
- walking charms, Pl. 163
- wash, definition of, p. 6
- weapons, pp. 67, 68, 137, 153
- wedge, iron, Pl. 139
- weights, p. 7; "bronze" —, Pl. 129;  
chert —, Pl. 129; flint —, Pl.  
168; hematite —, Pls. 129, 168;  
lead —, Pl. 168; limestone —, Pls.  
157, 161, 168; serpentine —, Pl.  
168; slate —, Pl. 168
- wet-smoothed, definition of, p. 6
- wheel, pottery, Pl. 85
- whetstone, basalt, Pl. 100; sandstone  
—, Pl. 130
- whitewashing of pottery, p. 116
- whorls, pp. 170-72; bone —, Pls. 84,  
95, 98, 100, 114, 119, 132, 153, 157,  
166, 171; ivory —, Pl. 95; lime-  
stone —, Pls. 85, 157; pottery —,  
Pls. 88, 110, 112, 142, 153, 161, 163;  
serpentine —, Pls. 157, 166; slate  
—, Pls. 154, 171; steatite —, Pls.  
84, 98, 100, 119, 132
- Wilensky, Emanuel, pp. ix, x
- Wilson, John A., p. ix
- wine, p. 89
- Winsor & Newton color chart, p. 6
- wire, silver, Pl. 132
- wood, pp. 132, 165, 186, Pls. 118, 125-  
26, 130
- Woodley, Ruby, pp. ix, x
- Woodward, Sir Arthur Smith, p. 212
- Woolley, Sir Leonard, p. x
- Woolman, Laurence C., p. ix
- Wright, G. Ernest, pp. 145, 148
- Yahūdiyyah, Tell el-, jugs, pp. 150-51
- Yazilikaya (Anatolia), p. 165
- Yeivin, S., p. x
- Zenjirli (Syria), p. 165
- zoomorphic vessel spout, Pl. 156

PLATES









No.	Field No.	Designation	Description	Date*
TOMB 903 UPPER (STAGES IV-V)				
1	P 3581	Bowl	Few minute mixed grits, poorly made, naples yellow 2	Stages IV-VII. Col. 20 A
2	P 3577	Bowl	Some light grits, poorly made, burnt umber 2 core, light red 3 to naples yellow 3 surface	Stages IV-VII. Col. 20 A
3	P 3583	Bowl	Few minute mixed grits, well made, roman sepia 3 core, naples yellow 2 inside surface, indian red 1 wash outside and over rim, close horizontal burnishing (see p. 143)	Stages III-V. Col. 14 C
4	P 3579	Bowl	Fine ware, many minute mixed grits, well made, well fired, blue-black 2 core, light red 2 surface, close horizontal burnishing outside and over rim (see pp. 143 and 146). See Pl. 76:1 for photograph.	Stages III-IV. Col. 22 B
5	P 3580	Bowl	Permanent brown 3 core, indian red 2 wash, close horizontal burnishing outside and over rim	Stages IV-VII. Col. 13 D
6	P 3578	Jug	Many minute mixed grits, well made, naples yellow 3, traces of indian red 2 wash	Stage V. Col. 28 F
7	P 3576	Jar	Well made, naples yellow 2, indian red 1 wash outside and over rim. See Pl. 76:2 for photograph.	Stages IV-VII. Col. 26
8	P 3582	Jar	Rim d. .22, coarse ware, many mixed grits, roman sepia 2 core, naples yellow 2 inside surface, light red 3 wash outside and over rim (see p. 143)	Stages IV-V. Col. 16 F
TOMB 903 LOWER (STAGES V-VII)				
9	P 4543	Bowl	Few minute dark grits, naples yellow 2, light red 2 wash (see p. 143)	Stages IV-VII. Col. 20 A
10	P 4545	Bowl	Few minute dark grits, naples yellow 2, blackened by fire around rim. See Pl. 76:8 for photograph.	Stages IV-VII. Col. 20 A
11	P 4544	Bowl	Same as No. 9. See Pl. 76:9 for photograph. Fragments of many other specimens of this type were found, some with rims blackened by fire, suggesting use as lamps.	Stages IV-VII. Col. 20 A
12	P 5236	Bowl	D. .33, few dark grits (calcite), permanent brown 3, blue-black 3 wash outside and over rim, close horizontal burnishing	Stages IV-VII. Col. 19 A
13	P 5225	Bowl	D. .31, some mixed grits, brown ocher 2 core, naples yellow 3 inside surface, indian red 1 wash outside and over rim, traces of horizontal burnishing	Stages IV-VII. Col. 19 A
14	P 5232	Bowl	D. .31; same as No. 13 except for naples yellow 3 core	Stages IV-VII. Col. 19 A
15	P 5231	Bowl	D. .32, permanent brown 3 core, naples yellow 2 inside surface, faded indian red 1 wash outside and over rim (see p. 143)	Stages IV-VII. Col. 19 A
16	P 5227	Bowl	D. .32, some minute dark grits, naples yellow 2 core, lighter inside surface, light red 2 wash outside and over rim, burnished, incised decoration (cf. Pl. 78:8)	Stages IV-VII. Col. 19 A
17	P 5237	Bowl	Same as No. 16 except for no decoration	Stages IV-VII. Col. 19 A
18	P 4536	Bowl	D. .30, some minute mixed grits, brown ocher 3 core, indian red 1 wash outside and over rim, spaced horizontal burnishing	Stages IV-VII. Col. 19 A
19	P 5228	Bowl	D. .36, many minute mixed grits, blue-black 3, light red 2 wash outside and over rim, incised decoration. See Pl. 78:7 for photograph.	Stages IV-VII. Col. 19 A
20	P 5233	Bowl	D. .31, some minute dark grits, naples yellow 2, light red 2 wash outside and over rim, incised decoration	Stages IV-VII. Col. 19 A
21	P 5235	Bowl	D. .31, blue-black 3, purple madder 3 wash	Stages IV-VII. Col. 19 A
22	P 5289	Bowl	D. .12; same as No. 27 except for no burnishing	Stages IV-VII. Col. 17 A
23	P 5288	Bowl	D. .20; same as No. 27	Stages IV-VII. Col. 17 A
24	P 5287	Bowl	D. .36; same as No. 27	Stages IV-VII. Col. 17 A
25	P 5290	Bowl	D. .44; same as No. 27 except for blue-black 3 core	Stages IV-VII. Col. 17 A
26	P 4546	Bowl	Same as No. 31 except for no burnishing (see p. 143)	Stages IV-VII. Col. 17 A
27	P 5286	Bowl	D. .24; naples yellow 2 core, lighter surface, close horizontal burnishing; gray burnished ware	Stages IV-VII. Col. 17 A
28	P 5230	Bowl	D. .36; same as No. 27 except for naples yellow 2 to blue-black 3 surface	Stages IV-VII. Col. 17 A
29	P 4520	Bowl	D. .34; same as No. 27	Stages IV-VII. Col. 17 A
30	P 5229	Bowl	D. .30; same as No. 27	Stages IV-VII. Col. 17 A
31	P 4540	Bowl	Naples yellow 3, close irregular burnishing; gray burnished ware (see pp. 143 f.). See Pl. 76:10 for photograph.	Stages IV-VII. Col. 18 A
32	P 4541	Bowl	Same as No. 31 except for no burnishing (see pp. 143 f.). See Pl. 76:11 for photograph.	Stages IV-VII. Col. 18 A
33	P 4487	Bowl	Many mixed grits, naples yellow 2, light red 2 wash outside and over rim. See Pl. 76:12 for photograph.	Stages IV-VII. Col. 13 A
34	P 4530	Jar	Many minute dark grits, well made, naples yellow 2, light red 2 wash outside and over rim (see p. 143). See Pl. 76:14 for photograph.	Stages IV-VII. Col. 23 C
35	P 4539	Jar	Brown ocher 3 core, naples yellow 2 surface, faded light red 3 wash outside and over rim	Stages IV-VII. Col. 26
36	P 4486	Jar	Many mixed grits, well made, blue-black 3 core, naples yellow 2 surface, indian red 2 trickle wash largely discolored to sepia (see p. 143). See Pl. 76:13 for photograph.	Stages III-VII. Col. 12 N
37	P 5262	Jar	Rim d. .13; same as No. 42	Stages IV-VII. Col. 12 P
38	P 5261	Jar	Rim d. .13, many minute mixed grits (calcite), brown ocher 2 core, naples yellow 1 surface, indian red 2 wash outside and over rim	Stages IV-VII. Col. 12 P
39	P 5260	Jar	Rim d. .13, many light grits, brown ocher 2 core, naples yellow 2 surface, faded burnt umber 2 wash outside and over rim	Stages IV-VII. Col. 12 P
40	P 5259	Jar	Rim d. .24; same as No. 45 except for calcite grits	Stages IV-VII. Col. 16 L
41	P 5258	Jar	Rim d. .23, many mixed grits (calcite), blue-black 3 core, naples yellow 2 surface	Stages V-VII. Col. 16 P
42	P 5263	Jar	Rim d. .17, many mixed grits, brown ocher 2 core, naples yellow 3 inside surface, chiefly indian red 2 wash outside and over rim	Stages VI-VII. Col. 16 K
43	P 5264	Jar	Rim d. .09; same as No. 42	Stages IV-VII. Col. 23 C
44	P 5265	Jar	Rim d. .17, many minute mixed grits (calcite), blue-black 3 core, naples yellow 2 surface	Stages VI-VII. Col. 16 K
45	P 5266	Jar	Rim d. .14, many dark grits, permanent brown 1 core, naples yellow 3 inside surface, chiefly light red 2 wash outside and over rim	Stages IV-VII. Col. 12 G
46	P 4529	Jug	Many minute dark grits, well made, naples yellow 2, traces of light red 2 wash. See Pl. 76:16 for photograph.	Stages IV-VII. Col. 24
47	P 4549	Jug	Same as No. 46 except for brown ocher 3 core	Stages IV-VII. Col. 24
48	P 4532	Jug	Same as No. 46	Stages IV-VII. Col. 24
49	P 4531	Jug	Same as No. 46; no indication of a second handle (see p. 143). See Pl. 76:15 for photograph.	Stages IV-VII. Col. 23
50	P 4537	Bowl	Many large grits, sepia 2 core, burnt umber 3 surface, wheelmade; intrusive	LB I
		Sherds	With pottery marks (see p. 12 and Fig. 7)	Chalcolithic

\* "Stages" do not date a given piece but indicate the duration of its type. See SAOC No. 10, pp. 52-65. For references to columns see *ibid.* chart.

TOMB 903 UPPER

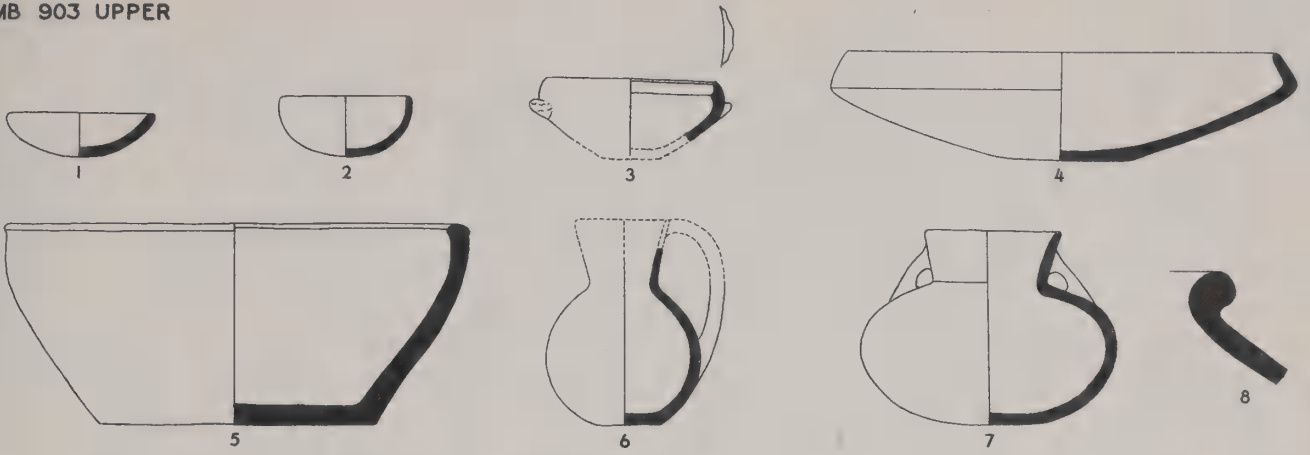

TOMB 903 LOWER

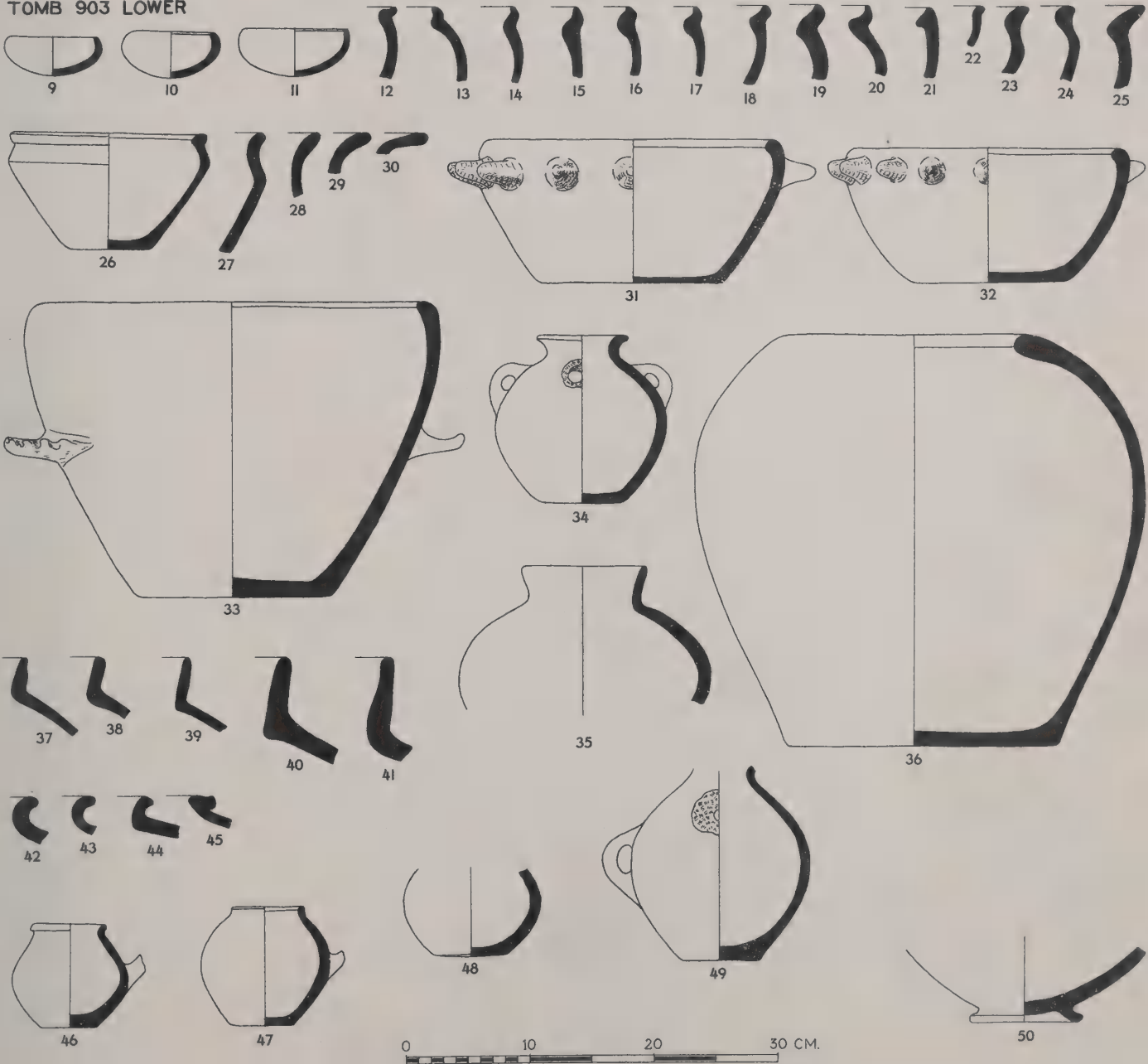

HANDMADE CHALCOLITHIC (EXCEPT NO. 50) POTTERY FROM TOMB 903 (SEE PP. 9-12). SCALE, 1:5

No.	Field No.	Designation	Description	Date*
TOMB 910 A ROCK (STAGES V-VI)				
1	P 5029	Bowl	D. .12, some minute dark grits, lightly fired, warm sepia 3 core, naples yellow 3 inside surface, indian red 2 wash	Stages IV-VII. Col. 20 A
2	P 5030	Jar	Rim d. .12, some minute dark grits, brown ocher 1, indian red 2 wash outside and over rim	Stages VI-VII. Col. 16 K
3	P 5028	Jar	Rim d. .18, coarse ware, many large mixed grits, poorly made, well fired, burnt umber 2, indian red wash faded to sepia outside and over rim	Stages IV-VI. Col. 16 L
4	P 5027	Jar	Rim d. .20, coarse ware, many mixed grits, brown ocher 2, light red 1 wash	Stages IV-V. Col. 16 E
TOMB 910 A FILL				
5	P 5018	Bowl	Fine ware, some light grits, well made, blue-black 3 core, naples yellow 3 inside surface, light red 1 wash outside and over rim, spaced irregular burnishing, wheelmade	Stages III-IV. Col. 21 B
6	P 5015	Bowl	Fine ware, some minute mixed grits, well made, burnt umber 2, light red 1 wash, spaced irregular burnishing, wheelmade	Stages IV-VII. Col. 21 C
7	P 5019	Bowl	D. .27, fine ware, many minute mixed grits, well made, well fired, blue-black 3 core, naples yellow 2 inside surface, brown 2 wash outside and over rim, spaced irregular burnishing, wheelmade	Stages III-IV. Col. 21 B
8	P 5017	Bowl	D. .31, well made, naples yellow 2, light red 1 wash outside and over rim, spaced irregular burnishing	Stages III-IV. Col. 21 A
9	P 5016	Bowl	Fine ware, few minute mixed grits, permanent brown 3 core, naples yellow 2 inside surface, light red 3 wash, wheelmade	Stage V. Col. 21 D
10	P 5021	Bowl	D. .15, some minute light grits, well made, blue-black 3 core, davy's gray 3 to blue-black 3 surface, horizontal burnishing	Stages IV-VII. Col. 17 A
11	P 5025	Jar	Rim d. .11, many mixed grits, lightly fired, brown ocher 3, indian red 2 wash outside and over rim	Stages IV-VII. Col. 26
12	P 5014	Jar	Rim d. .190, coarse ware, many mixed grits, blue-black 3 core, brown ocher 2 surface, indian red 2 grain wash	Stages IV-V. Col. 16 E
13	P 3770	Jar	Coarse ware, many minute mixed grits, lightly fired, burnt umber 1, blackened by fire. See Pl. 83:1 for photograph.	Stages I-III. Col. 12 C
TOMB 910 B FILL				
14	P 5320	Bowl	Same as No. 6	Stages IV-VII. Col. 21 C
15	P 5318	Bowl	D. .31, well made, blue-black 3 core, naples yellow 3 inside surface, light red 1 wash, close horizontal burnishing	Stages III-IV. Col. 21 B
16	P 5323	Bowl	D. .26, many dark grits, davy's gray 3, traces of light red 2 wash and horizontal burnishing; gray burnished ware	Stages IV-VII. Col. 17 A
17	P 5315	Jar	Rim d. .21, naples yellow 3, chiefly indian red 2 grain wash	Stages V-VII. Col. 16 G
18	P 5031	?	Many mixed grits, blue-black 3 core, naples yellow 2 inside surface, indian red 2 wash outside and over rim	?
TOMB 910 C FILL				
19	P 5034	Bowl	D. .290, fine ware, few mixed grits, well made, blue-black 3 core, naples yellow 1 outside surface, light red 2 wash inside and over rim, blackened inside to blue-black 2, close horizontal burnishing on rim, spaced vertical burnishing inside, wheelmade	Stages III-IV. Col. 21 B
20	P 5326	Bowl	D. .32, many minute grits, well made, permanent brown 3 core, naples yellow 3 inside surface with close horizontal burnishing, indian red 3 wash with irregular burnishing outside and over rim	Stages III-IV. Col. 21 B
21	P 5324	Jar	Rim d. .18, permanent brown 3 core, naples yellow 3 surface, blackened by fire	Stages IV-VII. Col. 12 G
TOMB 910 D FILL				
22	P 4910	Jar	Well made, brown ocher 2, indian red 2 wash outside and over rim, traces of burnishing. See Pl. 83:2 for photograph.	Stages IV-VII. Col. 14 G
23	P 5327	Jar	Rim d. .15, blue-black 3, indian red 2 wash outside and over rim	Stages III-VII. Col. 12 N
24	P 5328	Jar	Rim d. .20; same as No. 12	Stages IV-V. Col. 16 E
TOMB 910 E FILL				
25	P 5040	Bowl	Same as No. 12	Stages IV-VII. Col. 13 A
26	P 5335	Bowl	D. .35; same as No. 12 except for lighter wash	Stages IV-VII. Col. 13 A
27	P 5332	Bowl	D. .28; same as No. 29	Stages IV-VII. Col. 13 A
28	P 5334	Jar	Rim d. .40; same as No. 22 except for blue-black 2 and indian red 1 grain wash outside and over rim	Stages III-VII. Col. 12 N
TOMB 910 E UPPER				
29	P 5039	Bowl	D. .20, some minute mixed grits, well made, blue-black 3 core, naples yellow 2 inside surface, light red 1 wash outside and over rim, spaced irregular burnishing. A fragment of this vessel was found in T. 910 G Fill.	Stages III-IV. Col. 21 B
30	P 5038	Jar	Intact; some minute mixed grits, brown ocher 2 surface, incised decoration. See Pl. 83:3 for photograph.	?
TOMB 910 G FILL				
31	P 5341	Bowl	Same as No. 29	Stages IV-VII. Col. 21 C
32	P 5043	Bowl	D. .11; same as No. 15 except for lighter wash; wheelmade	Stages III-IV. Col. 21 A
33	P 5343	Bowl	D. .33, some minute mixed grits, permanent brown 3 core, naples yellow 3 inside surface, chiefly indian red 2 wash outside and over rim, spaced horizontal burnishing	Stages IV-VII. Col. 19 A
34	P 5344	Bowl	D. .25, few minute mixed grits, permanent brown 3 core, naples yellow 3 surface, horizontal burnishing; gray burnished ware	Stages IV-VII. Col. 17 A
35	P 5346	Bowl	Same as No. 29 except for naples yellow 3 core	Stages III-IV. Col. 21 B
36	P 5042	Jar	Blue-black 3 core, permanent brown 3 surface	Stages III-VII. Col. 25 B
37	P 5340	Jar	Rim d. .13; same as No. 33	Stages IV-VII. Col. 26
38	P 5339	Jar	Same as No. 33 except for close burnishing	Stages IV-VII. Col. 23 A
39	P 5046	?	Coarse ware, permanent brown 1 core, burnt umber 2 surface, traces of indian red 2 wash, raised rope decoration	?
TOMB 910 H				
40	P 5351	Bowl	D. .14, some minute mixed grits, permanent brown 3, wheelmade, string-cut base	Stages I-IV. Col. 2
41	P 5349	Bowl	Naples yellow 3, indian red 2 wash reduced to sepia 2 on rim; found in wall	?
42	P 5348	Jar	Roman sepia 2 core, burnt umber 1 surface; found in wall	Stages IV-V. Col. 12 K
	P 5350	Bowl	Gray burnished ware; found in wall	Stages IV-VII. Col. 17 A

\* "Stages" do not date a given piece but indicate the duration of its type. See SAOC No. 10, pp. 52-65 and chart.

TOMB 910 A ROCK

TOMB 910 A FILL

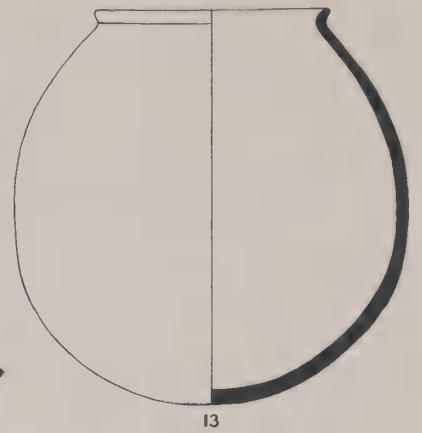
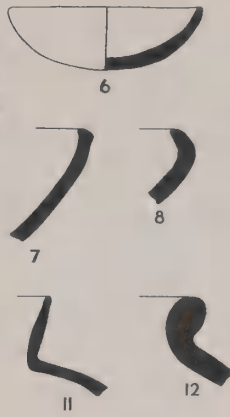
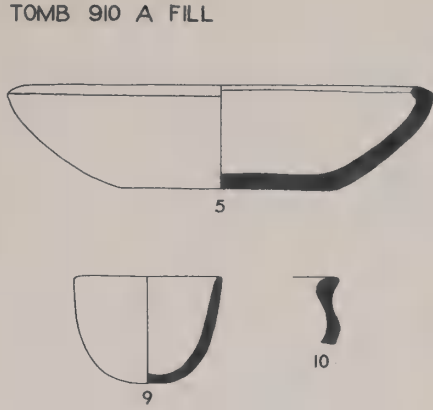
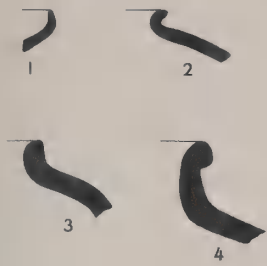

TOMB 910 B FILL

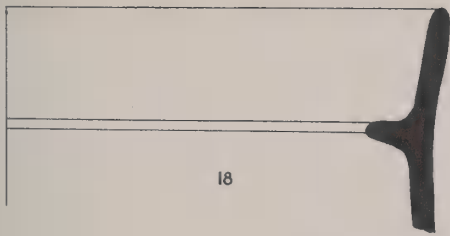
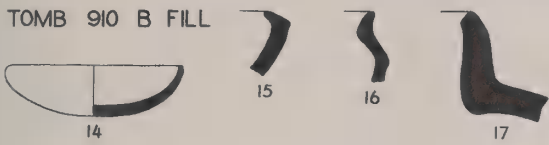

TOMB 910 C FILL



TOMB 910 D FILL

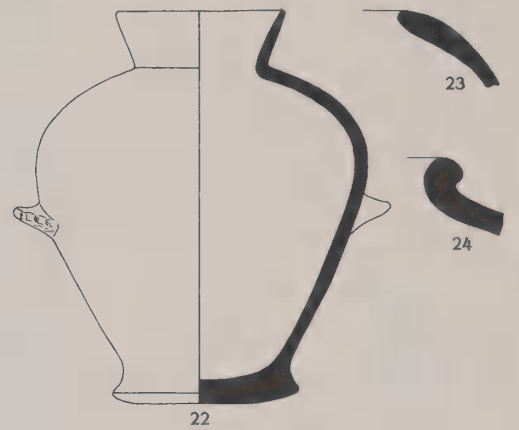

TOMB 910 E FILL

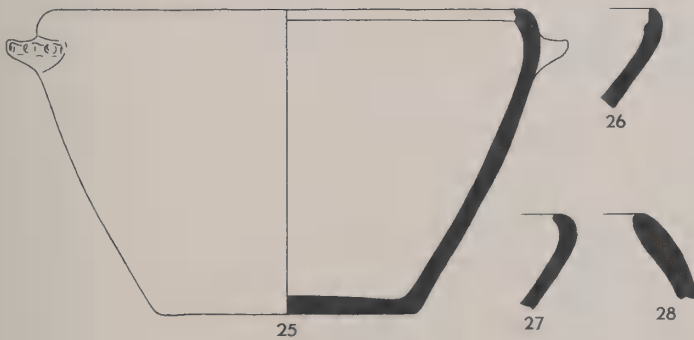

TOMB 910 E UPPER

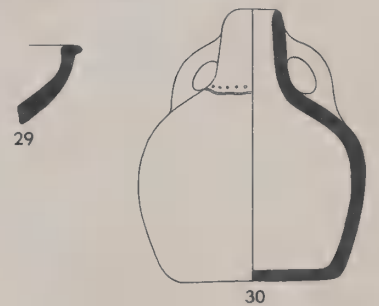

TOMB 910 G FILL



TOMB 910 H

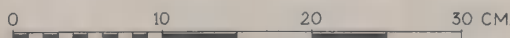
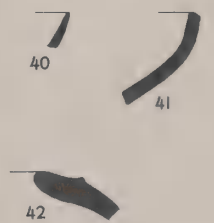

No.	Field No.	Designation	Description	Date*
TOMB 1122 SHELF (STAGES IV-VII)				
1	P 4081	Jar	Some minute mixed grits, well made, brown ocher 3, indian red 3 wash outside, handmade	Stages IV-VII. Col. 26
2	P 4076	Jug	Some minute dark grits, naples yellow 3, light red 2 wash outside and over rim, handmade	Stage V. Col. 28 <i>F</i>
3	P 4082	Bowl	D. .275, many minute mixed grits, naples yellow 2, indian red 2 wash outside and over rim, handmade	Stages IV-VII. Col. 13 <i>A</i>
TOMB 1122 UPPER				
4	P 4074	Bowl	Complete, many mixed grits, brown ocher 2 surface	LB II
	P 4075	Bowl	Same type as No. 4	LB II
5	P 4073	"Cup and saucer"	Many light grits, poorly made, permanent brown 3 core, brown ocher 2 surface	LB II
6	P 4072	Jar	Many light grits, blue-black 3 core, burnt umber 2 surface	LB II
7	P 4080	Jar	Few light grits, permanent brown 3 core, burnt umber 2 surface, permanent yellow 3 slip, pottery mark on handle	LB II
	P 4079	Jar	Same type as No. 7	LB II
	P 4078	Jar	Same shape as No. 7, many mixed grits, blue-black 3 core, brown ocher 2 surface	LB II
TOMB 1128†				
8	P 4045	Jar	Fine ware, well made, chiefly naples yellow 3, light red 2 wash outside and over rim, decorative vertical burnishing, handmade. See Pl. 84:23 for photograph.	Stage IV
9	P 4047	Jug	Same as No. 8 except for minute grits. See Pl. 84:24 for photograph.	Stage IV
10	P 4046	Jug	Same as No. 8 except for no grits. See Pl. 84:25 for photograph.	Stage IV
11	P 4050	Bowl	Fine ware, few minute grits, well made, naples yellow 3, light red 2 wash outside and over rim, close vertical burnishing outside, handmade. See Pl. 84:22 for photograph.	Stage IV
12	P 4051	Bowl	Same as No. 11 except for horizontal burnishing and closely burnished base. See Pl. 84:20 for photograph.	Stage IV
	P 4052-53	Bowls	Same type as No. 12	Stage IV
13	P 4048	Bowl	Same as No. 12 with one horizontally pierced lug handle. See Pl. 84:21 for photograph.	Stage IV
TOMB 1128 FILL				
14	P 4063	Bowl	Few minute grits, naples yellow 2, light red 2 wash outside down to carination and inside slightly farther, spaced horizontal burnishing outside, widely spaced irregular burnishing inside, handmade	?
15	P 4065	Platter	Some minute mixed grits, black lead 3 core, naples yellow 3 surface, handmade	Stages I-IV. Col. 1 <i>B</i>
16	P 4064	Bowl	Few minute grits, permanent brown 3 core, naples yellow 3 surface, string-cut base	Stages I-IV. Col. 2
17	P 4060	Jar	Many light grits, blue-black 3 core, brown ocher 2 and naples yellow 2 surface, handmade; probably the rim of Pl. 7:11	Stages I-II. Col. 16 <i>A</i>
Sherds				MB I, LB, MI

\* "Stages" do not date a given piece but indicate the duration of its type. See SAOC No. 10, pp. 52-65 and chart.

† See *ibid.* pp. 23-24 and Fig. 7.

TOMB 1122 SHELF

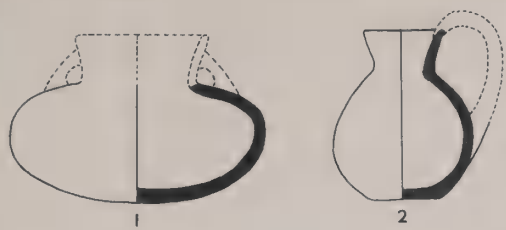

TOMB 1122 UPPER

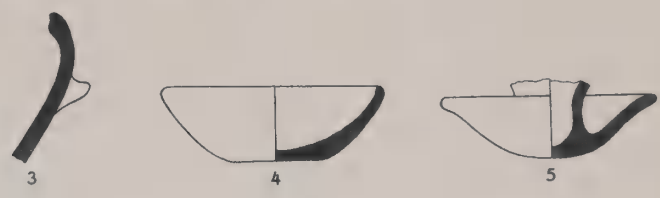

TOMB 1122 UPPER

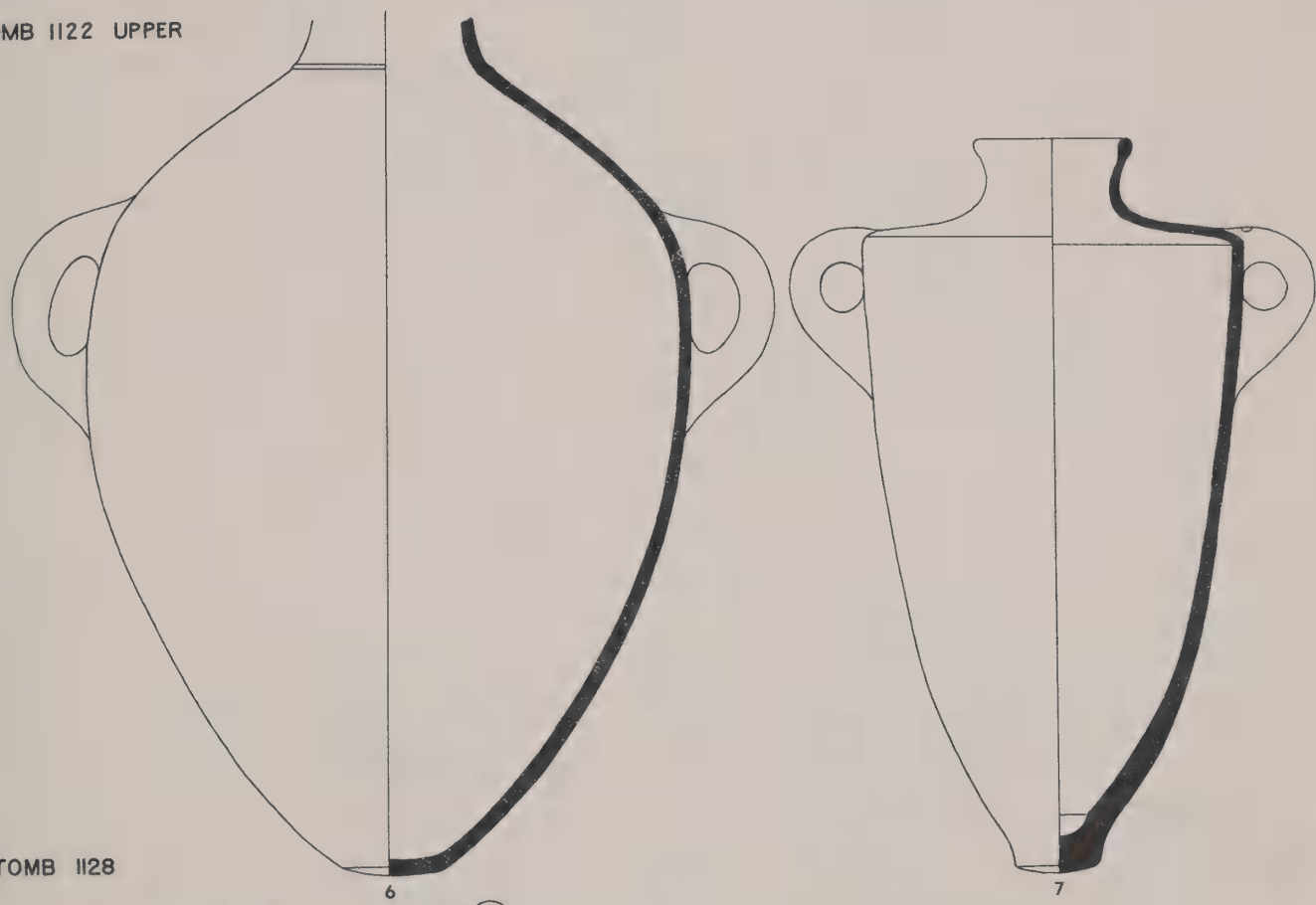

TOMB 1128

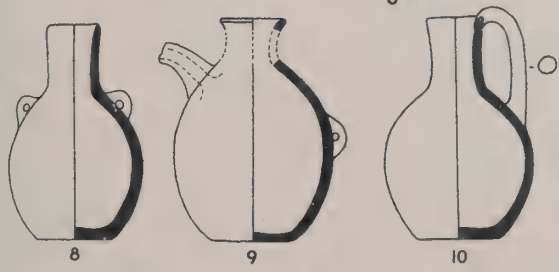

TOMB 1128 FILL

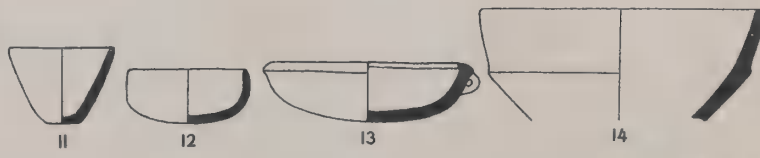

TOMB 1128 FILL

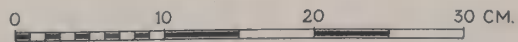
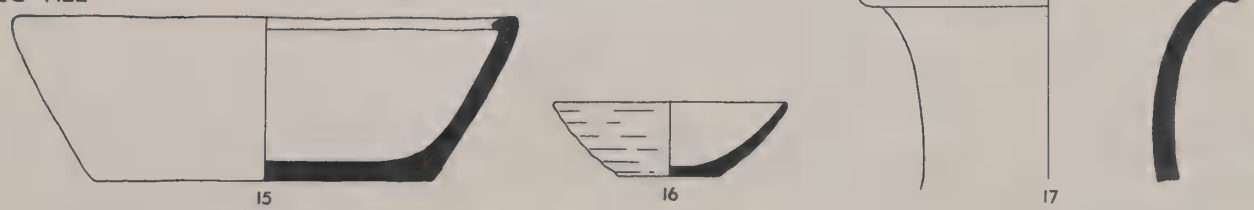

No.	Field No.	Designation	Description	Date*
TOMB 52				
1	x 1796	Bowl	Brown ocher 3, indian red 2 decoration, handmade (see p. 146). See Pl. 85:3 for photograph.	Probably Stages I-III. Cf. Col. 6.
2	x 1896	Bowl	Brown ocher 3, indian red 3 slip outside and over rim, handmade	Probably Stages I-III
3	x 01895	Bowl	Brown ocher 3, indian red 2 decoration (see p. 146)	Stages I-III. Col. 6 A
4	1797	Jar	Brown ocher 3, indian red 3 decoration, string-cut base, crude ledge handles (see p. 146). See Pl. 85:1 for photograph.	Stages I-III. Col. 5 A
5	0935 a	Jug	Naples yellow 1 (see p. 146)	Stages I-III. Col. 3
6	x 1902	Jug	Charcoal gray 3 core, brown ocher 3 surface. See Pl. 85:4 for photograph.	LB II
7	x 1901	Jug	Brown ocher 3. See Pl. 85:5 for photograph.	MI
		Sherds		LB II, MI
TOMB 1106				
8	P 4498	Bowl	Blue-black 3 core, naples yellow 2 surface (see p. 146)	Stages I-IV. Col. 1 A
9	P 4494	Jar	Many minute light grits (calcite), naples yellow 3, traces of trickle wash, drilled pottery mark, handmade	?
10	P 4496	Jar	Many minute light grits, naples yellow 2, indian red 2 trickle wash outside, raised rope decoration, handmade	?
11	P 4492	Jar	Many predominantly dark grits (calcite), burnt umber 2, raised rope decoration, handmade	?
12	P 4499	Jar	Many minute dark grits, naples yellow 2, pottery mark, handmade	Stages III-V. Col. 14 D
13	P 4495	Jar	Minute mixed grits, permanent brown 2 core, warm sepia 3 surface, pottery mark, handmade (see p. 146)	Stages I-III. Col. 12 B
14	P 4493	Jar	Minute grits (calcite), permanent brown 2, traces of reddish trickle wash, pottery mark, handmade	Stages IV-VII. Col. 12 D
15	P 4488	Bowl	Many minute dark grits, well made, naples yellow 2 to 3, close horizontal burnishing outside and over rim, base blackened by fire, handmade; gray burnished ware; found with No. 16 (see Fig. 20) in hole in floor below skeletons	Stages IV-VII. Col. 17 A
16	P 4489	Bowl	Complete; same as No. 15	Stages IV-VII. Col. 17 A
	M 3647	Vessel	Basalt (Fig. 21)	Chalcolithic
TOMB 1101 A LOWER (EB, STAGE 0-I)				
17	P 4140	Jar	Naples yellow 2 (see p. 147)	Stage 0-I
18	P 4144	Bowl	Some minute mixed grits, naples yellow 3, light red 2 decoration (see p. 146)	Stages I-III. Col. 6 A
19	P 4143	Platter	Few minute mixed grits, naples yellow 2 (see p. 146)	Stages I-IV. Col. 1 B
TOMB 1101 B LOWER (EB, STAGE 0-I)				
20	P 5352	Bowl	Few minute mixed grits, naples yellow 3, traces of light red 3 wash, handmade; probably intrusive	Stages IV-VII. Col. 20 A
21	P 4126	Bowl	Permanent brown 3 core, naples yellow 2 surface, string-cut base (see p. 146)	Stages I-IV. Col. 2
	P 4134	Bowl	Same type as No. 21	Stages I-IV. Col. 2
22	P 4123	Bowl	Many minute mixed grits, naples yellow 2, traces of light red 2 wash, handmade, hole in base (see p. 147). See Pl. 85:16 for photograph.	Stage 0-I
	P 4132	Bowl	Same type as No. 22	Stage 0-I
23	P 4135	Bowl	Many light grits, lightly fired, burnt umber 2 core, burnt umber 3 surface, handmade. See Pl. 85:17 for photograph.	Stage 0-I
24	P 5282	Platter	Permanent brown 2 core, naples yellow 2 inside surface, indian red 2 wash outside and over rim, handmade (see p. 146)	Stages I-IV. Col. 1 C
25	P 5246	Platter	Same as No. 24 except for naples yellow 2 core	Stages I-IV. Col. 1 A
26	P 4138	Jug	Some minute light grits, brown ocher 1, light red 1 wash outside and over rim, spaced irregular burnishing, handmade	Stages I-IV. Col. 11 D
27	P 4136	Jar	Many minute light grits, brown ocher 3, incised decoration, handmade (see p. 147)	Stage 0-I
28	P 4142	Jar	Many minute mixed grits, brown ocher 2, incised decoration, handmade; traces of an awkward spout close to rim (see p. 147)	Stage 0-I
29	P 4120	Jar	Many minute mixed grits, blue-black 2 core, brown ocher 3 surface, handmade (see p. 147). See Pl. 85:18 for photograph.	Stage 0-I
30	P 4124	Jar	Many minute mixed grits, naples yellow 2, incised decoration, handmade (see p. 147)	Stage 0-I
31	P 4122	Jar	Many minute mixed grits, permanent brown 3 core, brown ocher 3 surface, incised decoration, handmade (see p. 147). See Pl. 85:19 for photograph.	Stage 0-I
	P 4128	Platter	Same type as No. 19; mending hole	Stages I-IV. Col. 1 B

\* "Stages" do not date a given piece but indicate the duration of its type. See SAOC No. 10, pp. 52-65 and chart.

TOMB 52

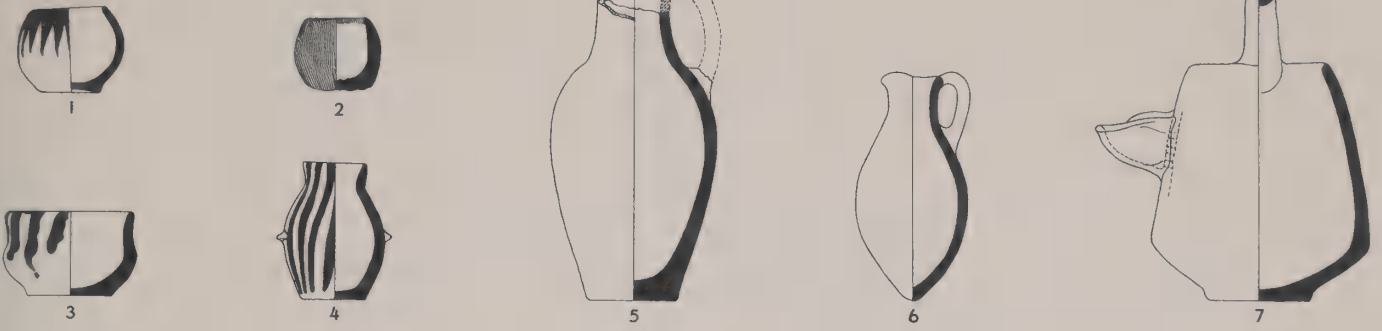

TOMB 1106

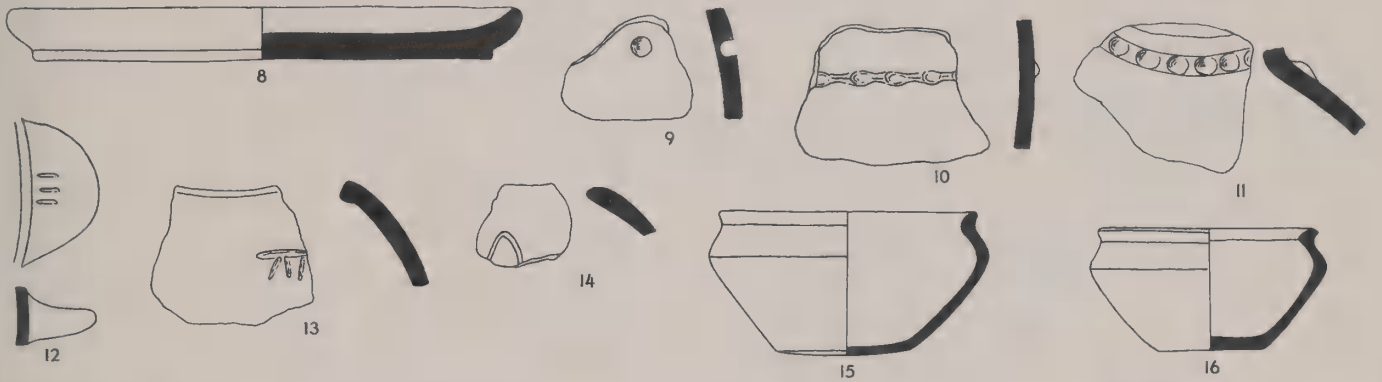

TOMB 1101 A LOWER



TOMB 1101 B LOWER

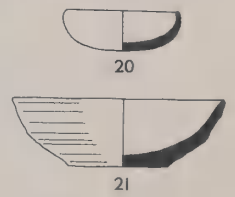

TOMB 1101 B LOWER

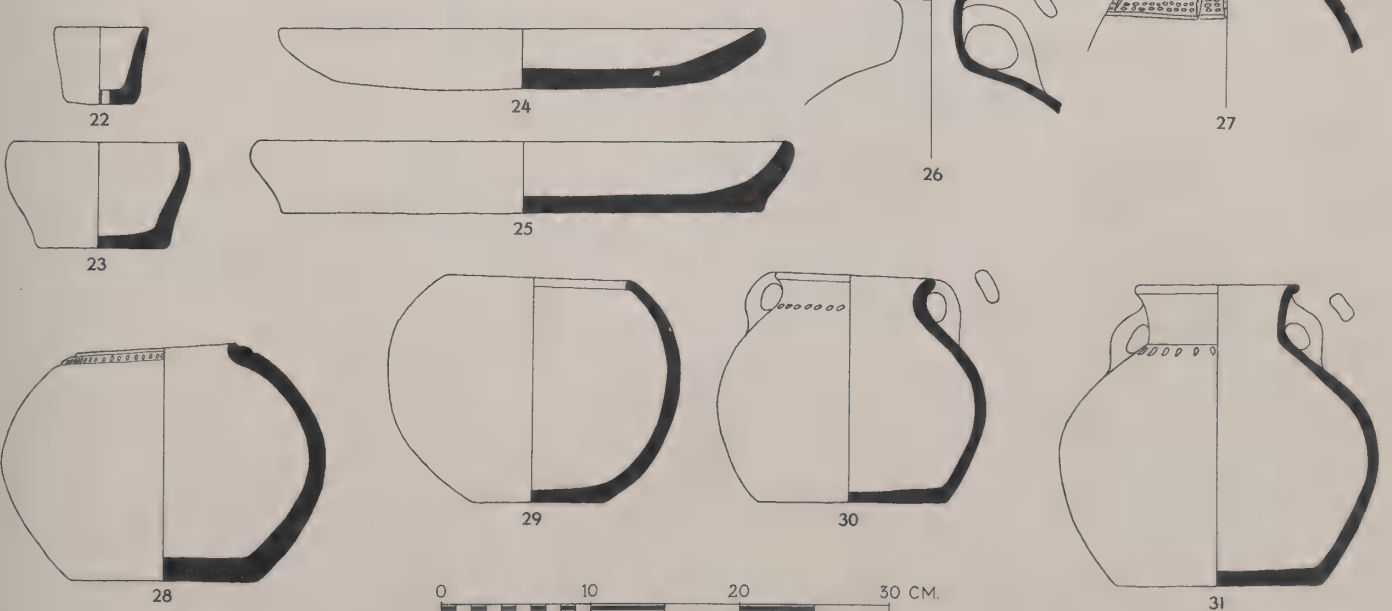

No.	Field No.	Designation	Description	Date*
TOMB 1101 B LOWER (EB, STAGE 0-I)				
1	P 4139	Jar	Many minute mixed grits, well fired, permanent brown 3 core, brown ocher 2 surface, handmade (see p. 147)	Stage 0-I. Col. 25 A
2	P 4131	Jar	Many minute mixed grits, permanent brown 3 core, naples yellow 2 surface, partially folded ledge handles, handmade (see p. 147)	Stage 0-I. Col. 14 AA
3	P 4121	Jar	Many minute mixed grits, brown ocher 2, partially folded ledge handles, handmade (see p. 147)	Stage 0-I. Col. 14 AA
4	P 4137	Jar	Many large mixed grits, black lead 3 core, naples yellow 2 surface, handmade (see p. 146)	Stages I-III. Col. 12 Q
5	P 4133	Jar	Many mixed grits, blue-black 3 core, brown ocher 2 surface, pottery mark, handmade (see p. 146)	Stages I-IV. Col. 12 A
6	P 4125	Jar	Many mixed grits, brown ocher 1, handmade (see p. 146). For probable shape see Bliss and Macalister, <i>Excavations in Palestine</i> , Pl. 23:1 S.	Stages I-II. Col. 16 A
7	P 4141	Plate	D. .35, naples yellow 2, handmade; probably reused base of jar (see p. 146)	Stage 0-I
8	P 4130	Jar	Rim d. .205, many mixed grits, brown ocher 3, handmade (see p. 147)	Stages I-IV. Col. 12 A
TOMB 1102 LOWER (EB, STAGE 0-I)				
9	P 4485	Bowl	Many mixed grits, brown ocher 1, handmade (see p. 147)	Stage 0-I
10	P 4632	Platter	Few minute mixed grits, black lead 3 core, naples yellow 2 surface	Stages I-IV. Col. 1 A
11	P 4633	Jar	Many light grits, blue-black 3 core, brown ocher 2 surface, handmade; probably the base of Pl. 5:17 (cf. Bliss and Macalister, <i>loc. cit.</i> )	Stages I-II. Col. 16 A
12	P 4631	Jar	Rim d. .14, some minute mixed grits, warm sepia 3, pottery mark, handmade	Stages I-IV. Col. 12 A
13	P 4482	Jar	Many minute mixed grits, permanent brown 2 core, brown ocher 3 surface, partially folded ledge handles, handmade (see p. 147). See Pl. 85:11 for photograph.	Stage 0-I. Col. 14 AA
14	P 4484	Jar	Many minute light grits, permanent brown 3 core, brown ocher 2 to naples yellow 1 surface, incised decoration, handmade (see p. 147)	Stage 0-I. Col. 25 A
15	P 4483	Jar	Many minute dark grits, naples yellow 2, handmade (see p. 147)	Stage 0-I. Col. 25 A

\* "Stages" do not date a given piece but indicate the duration of its type. See SAOC No. 10, pp. 52-65 and chart.

TOMB 1101 B LOWER

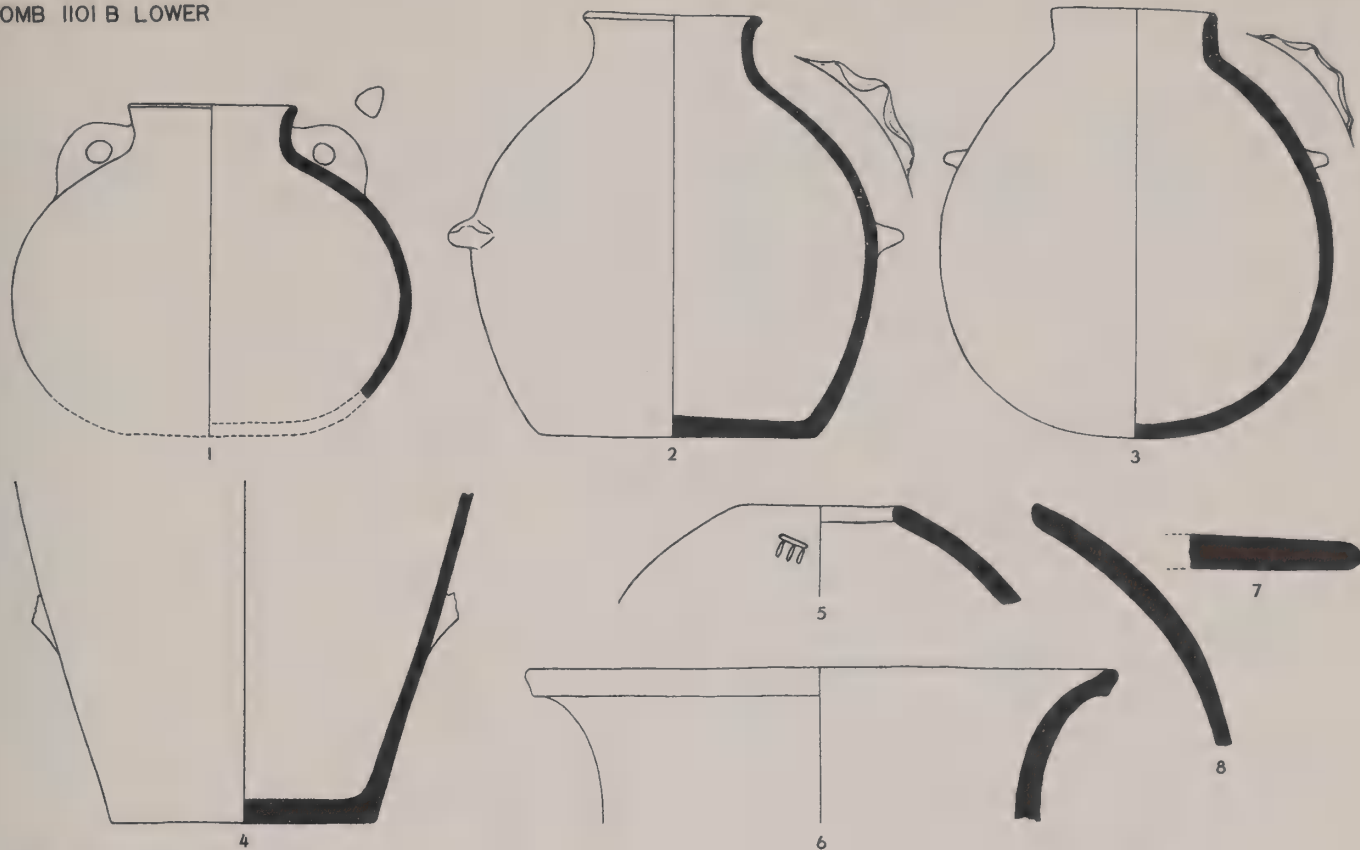

TOMB 1102 LOWER

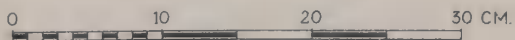
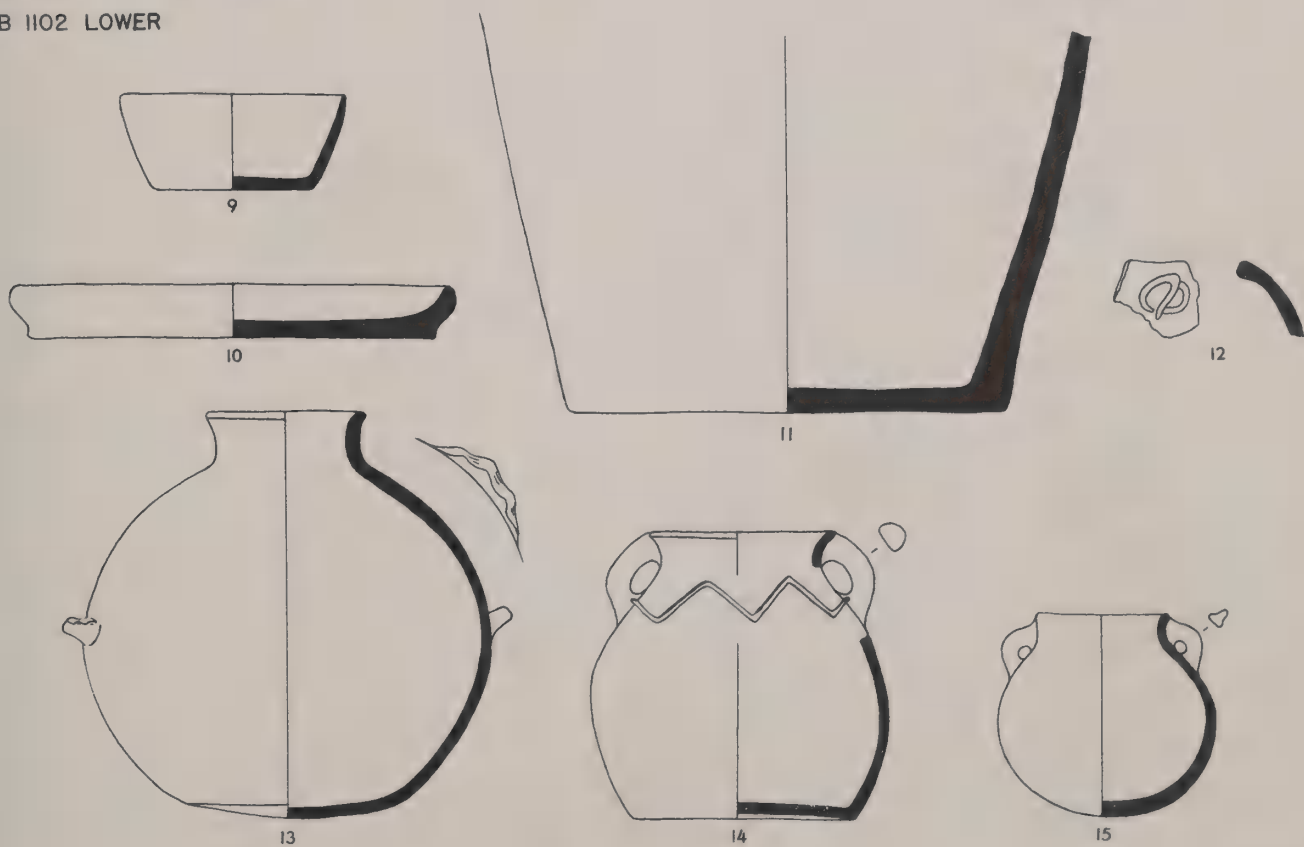

EB (STAGE 0-1) POTTERY FROM TOMBS 1101-2 (SEE PP. 24-27). SCALE, 1:5

No.	Field No.	Designation	Description
<b>TOMB 1101 A UPPER</b>			
1	P 4089	Jug	D. .35, some dark grits, well made, brown ocher 3, naples yellow 1 slip, close horizontal burnishing, brown 1 to near light red 1 decoration (broken-line spiral represents traces of erased decoration, probably an unsuccessful attempt of the artist); Aegean(?) (see p. 160). See Pl. 87:2 for photograph.
2	P 4086	Flask	T. .055, brown ocher 3 core, naples yellow 3 surface, indian red 2 decoration (spiral around ringed dot)
	P 4085	Flask	Same type as No. 2 except for brown ocher 2 surface; EI I
3	P 4087	Chalice	Poorly made, blue-black 3 core, brown ocher 2 surface (see p. 159)
4	P 4088	Lamp	Blue-black 3 core, burnt umber 3 surface
<b>TOMB 1101 B UPPER</b>			
5	P 4091	Bowl	Rim d. .20, blue-black 3 core, burnt umber 3 surface, spaced horizontal burnishing, indian red 2 and purple madder 2 decoration, pottery mark on one handle. See Pl. 87:9 for photograph.
6	P 4093	Bowl	Permanent brown 3 core, brown ocher 2 surface. See Pl. 87:8 for photograph.
	P 4094	Bowl	Same type as No. 6 except for naples yellow 2 core and surface; EI I
7	P 4095	Bowl	Permanent brown 3 core, chiefly burnt umber 2 surface
8	P 4099	Bowl	Permanent brown 3 core, brown ocher 3 surface. See Pl. 87:3 for photograph.
	P 4098	Bowl	Same shape as No. 8, large grits, blue-black 3 core, naples yellow 2 surface; EI I
9	P 4097	Bowl	Many mixed grits, permanent brown 3 core, naples yellow 2 surface, 8 handles
10	P 4092	Bowl	Many mixed grits, well fired, naples yellow 2
11	P 4101	Jug	Permanent brown 1 core, chiefly naples yellow 2 surface, indian red 3 decoration
12	P 4102	Jug	Blue-black 3 core, brown ocher 1 surface, close vertical burnishing, faded sepia and indian red 2 decoration (see p. 159). See Pl. 87:4 for photograph.
	P 4108	Jug	Same type as No. 12 except for no burnishing or decoration; EI I
13	P 4096	Jug	Many mixed grits, well fired, permanent brown 3 core, burnt umber 2 to naples yellow 3 surface (see p. 159)
14	P 4105	Chalice	Few mixed grits, naples yellow 2 (see p. 159)
	P 4104	Chalice	Same type as No. 14; EI I
15	P 4106	Lamp	Naples yellow 2
16	P 4107	Flask	Blue-black 3 core, naples yellow 2 surface (see p. 159)
	P 4103	Jug	Same type as No. 18; EI I
<b>TOMB 1101 C</b>			
17	P 4113	Flask	Some minute mixed grits, burnt umber 3, indian red 2 spiral decoration (see p. 159)
18	P 4112	Jug	Few minute mixed grits, blue-black 3 core, brown ocher 2 surface, close vertical burnishing
19	P 4117	Bowl	Some minute mixed grits, burnt umber 3, spaced irregular burnishing inside and over rim (see p. 159)
20	P 4111	Bowl	Poorly made, blue-black 3 core, brown ocher 3 surface (see p. 159)
21	P 4116	Bowl	Blue-black 3 core, naples yellow 2 surface (see p. 159)
22	P 4115	Bowl	Few minute mixed grits, permanent brown 3 core, naples yellow 2 surface, blue-black 2 decoration, horizontal loop handles; Philistine ware (see pp. 159 and 162)

TOMB 1101 A UPPER

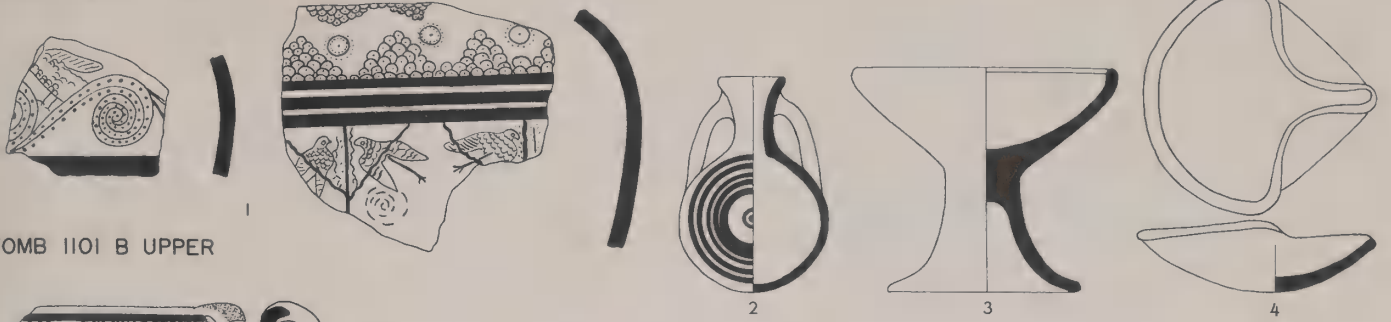

TOMB 1101 B UPPER

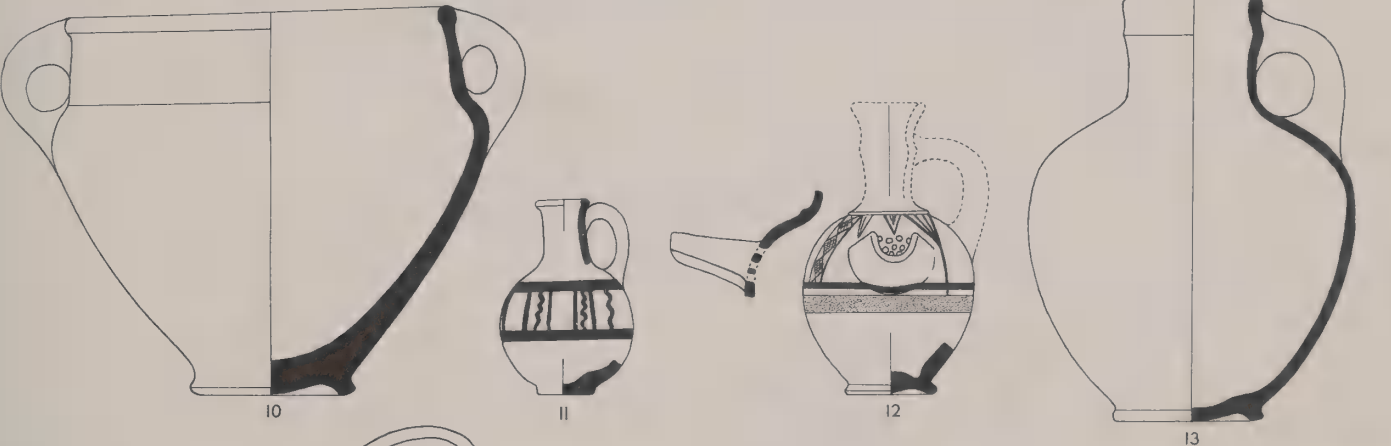
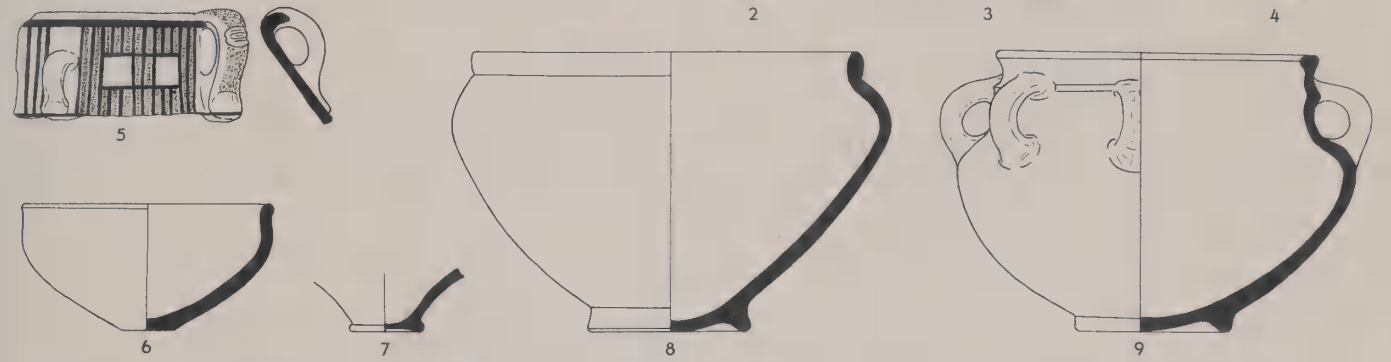

TOMB 1101 C

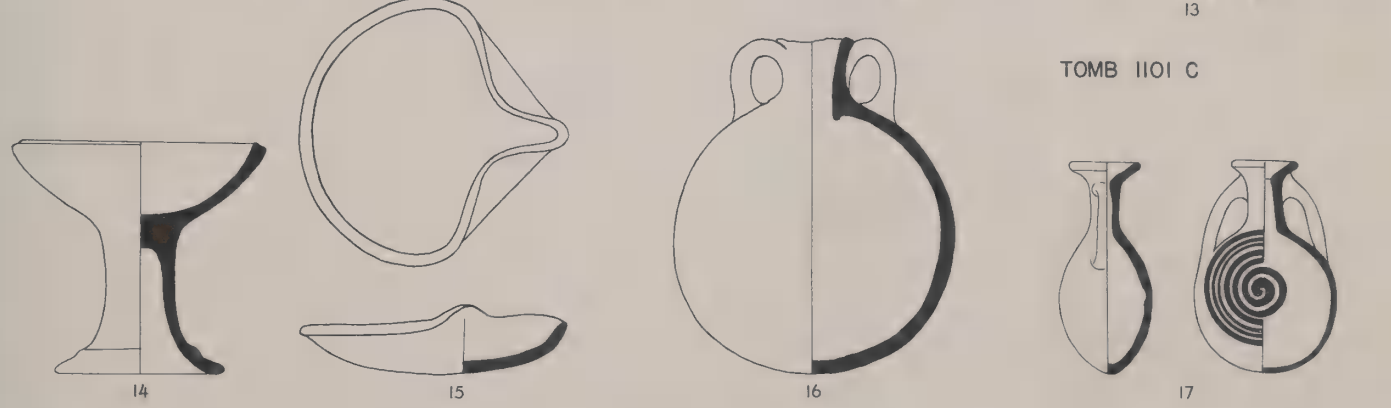

TOMB 1101 C

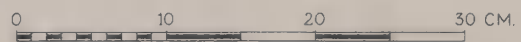
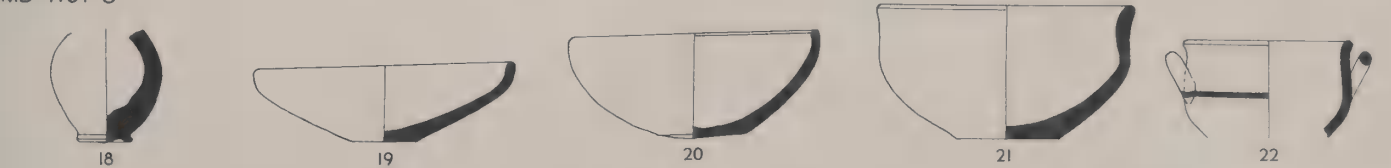

EI I POTTERY FROM TOMB 1101 (SEE PP. 24-27). SCALE, 1:5

No.	Field No.	Description
TOMB 1101 C		
1	P 4110	Some minute mixed grits, naples yellow 2
2	P 4118	Many light grits, black lead 3 core, naples yellow 2 surface, indian red 2 decoration
3	P 4119	Many minute mixed grits, well fired, blue-black 2 core, brown ocher 2 to naples yellow 2 surface, light red 2 decoration, 12 handles; part found in T. 1102 Upper (see Figs. 24-25)
	P 4109	Bowl; same shape as Pl. 8:8, blue-black 3 core, brown ocher 3 surface (see Fig. 24); EI I
TOMB 1102 UPPER		
4	P 4145	Some minute mixed grits, naples yellow 2, traces of indian red 2 decoration. See Pl. 87:10 for photograph.
	P 4147	Bowl; same shape as Pl. 8:20, few minute mixed grits, blue-black 3 core, naples yellow 2 surface; EI I
	P 4146	Flask; same shape as Pl. 8:2, brown ocher 2, indian red 2 decoration (see Fig. 25); EI I

TOMB 1101 C

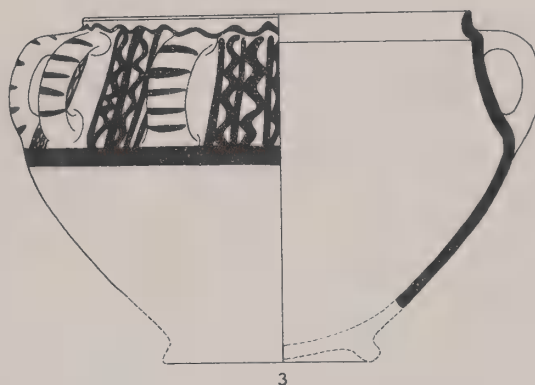
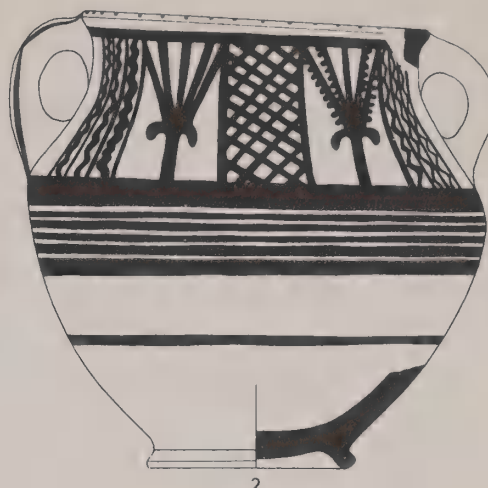
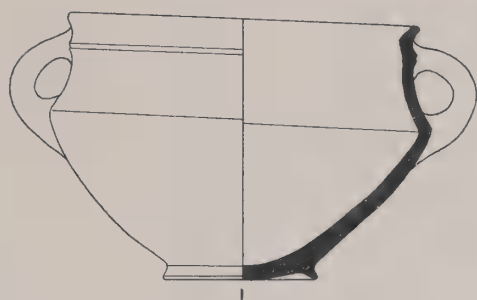

TOMB 1102 UPPER

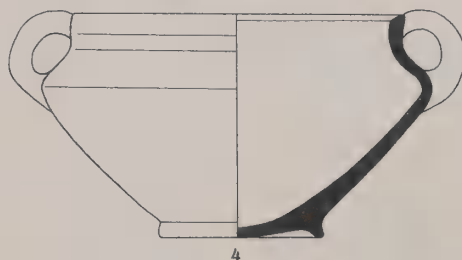

No.	Field No.	Designation	Description	Date*
TOMB 9				
1	x 2863	Bowl	Brown ocher 1 core, charcoal gray 3 and blue-black 3 surface, extremely well polished; Khirbet Kerak ware (see p. 147)	EB
TOMB 41				
2	x 802	Bowl	Brown ocher 3, handmade. See Pl. 88:1 for photograph.	MB I
3	x 803	"Teapot"	Brown ocher 3, indian red 1 wash outside and over rim. See Pl. 88:4 for photograph.	MB I
4	x 804	"Teapot"	Indian red 3. See Pl. 88:5 for photograph.	MB I
5	x 801	"Teapot"	Indian red 3 core and inside surface, blue-black 3 outside surface, Naples yellow 3 decoration (see pp. 29 and 148). See Pl. 88:3 for photograph.	MB I
6	x 805	Jug	Brown ocher 3, indian red 3 wash outside and over rim, handmade	MB I
7	x 5	Jar	Brown ocher 2, handmade	MB I
8	x 0806 a	Jar	Naples yellow 2, handmade	MB I
9	x 0806	Jar	Permanent yellow 3, incised decoration, folded ledge handles, handmade (see p. 148). See Pl. 88:7 for photograph.	MB I
	x 6	Jar	Same type as No. 9	MB I
10	x 0806 b	Jar	Permanent yellow 3, folded ledge handles, handmade. See Pl. 88:6 for photograph.	MB I
	x 9	Jar	Same type as No. 10	MB I
	x 2	Bowl	Same type as Pl. 68:12	EI I
TOMB 67 A				
11	P 23	Jug	Indian red 3, burnt umber 3 wash inside and over rim	MB I
12	P 24	Jar	Permanent brown 3	MB I
13	P 21	"Teapot"	Naples yellow 3	MB I
14	P 22	Jug	Charcoal gray 2 core, burnt umber 3 surface; probably intrusive	LB?
15	3995	Jug	Burnt umber 3; intrusive	MB II (cf. Pl. 28:41)
	3996	Jug	Burnt umber 1, burnt umber 3 wash, irregular hand burnishing; intrusive	EI II
TOMB 217 B				
16	P 286	Bowl	Some light grits, poorly made, brown ocher 3. See Pl. 90:19 for photograph.	MB I
17	P 352	Bowl	Same as No. 16. See Pl. 90:20 for photograph.	MB I
18	P 288	Jar	Well fired, permanent brown 3, roman sepia 2 decoration. See Pl. 90:16 for photograph.	MB I
19	P 289	Jar	Some dark grits, poorly made, well fired, permanent brown 3	MB I
20	P 291	Jar	Permanent brown 1 core, brown ocher 3 surface, indian red 3 wash outside and over rim. See Pl. 90:17 for photograph.	MB I
21	3493	Jug	Lightly fired, burnt umber 3	MB I
22	3635	Jug spout	Some dark grits, sepia 3, intensive light red 1 wash, burnished, handmade; intrusive	Stages IV-VII. Col. 23
23	P 284	Jar	Same as No. 20. See Pl. 90:15 for photograph.	MB I
24	P 269	"Teapot"	Same as No. 20. See Pl. 90:10 for photograph.	MB I
25	P 295	"Teapot"	Some minute dark grits, well fired, burnt umber 3. See Pl. 90:14 for photograph.	MB I
26	5537	Jug	Some dark grits, burnt umber 3	MB I
27	3644	Lamp	Some light grits, burnt umber 2 (see p. 149)	MB I
28	P 271	Lamp	Coarse ware, some large dark grits, poorly made, lightly fired, permanent brown 3 (see p. 149). See Pl. 90:21 for photograph.	MB I

\* "Stages" do not date a given piece but indicate the duration of its type. See SAOC No. 10, pp. 52-65 and chart.

TOMB 9

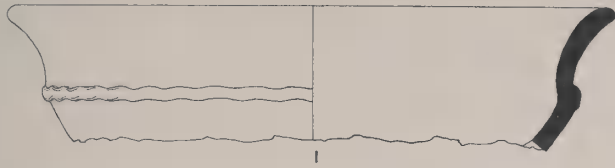

TOMB 41

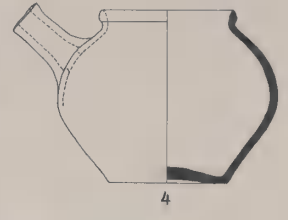
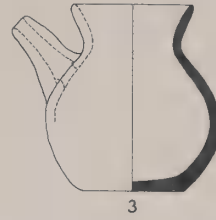
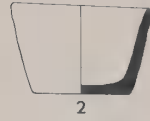

TOMB 41

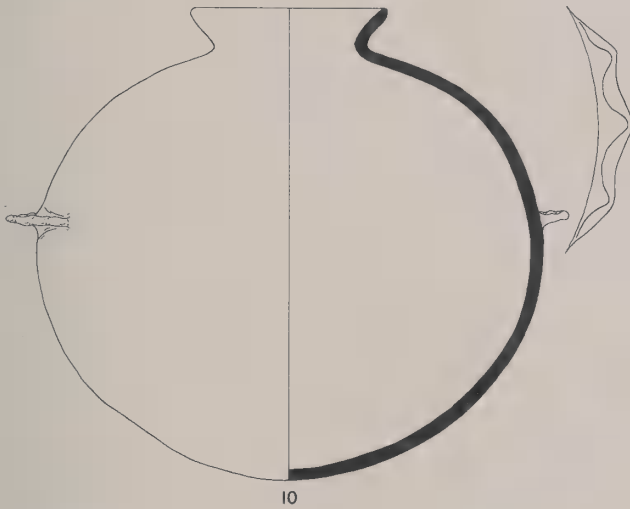
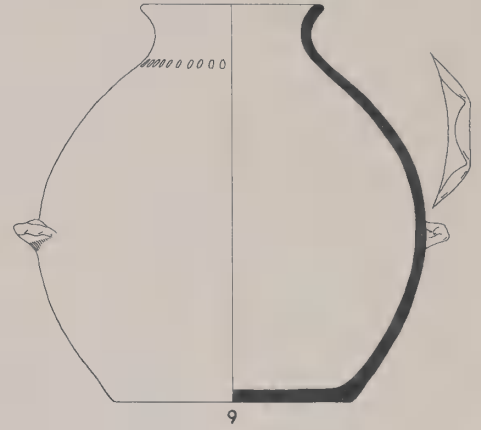
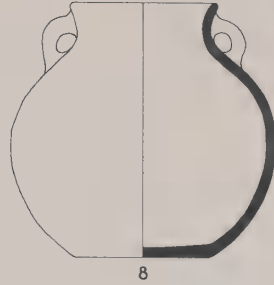
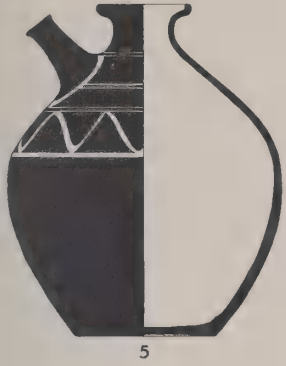

TOMB 67 A

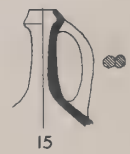
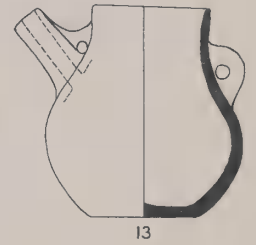
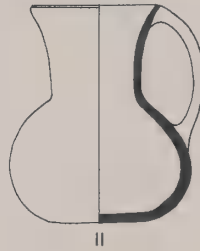

TOMB 217 B

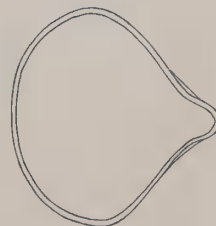
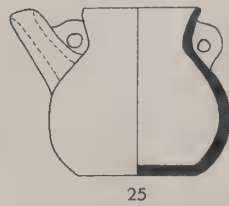
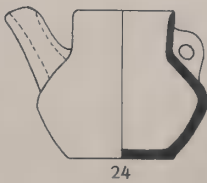
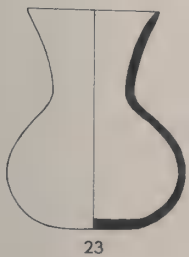
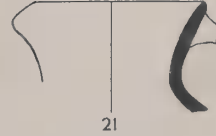
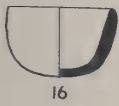

POTTERY FROM TOMBS 9, 41, 67 A, AND 217 B (SEE PP. 20, 29, AND 31). SCALE, 1:5

No.	Field No.	Designation	Description	Date
TOMB 217 C				
1	P 270	Bowl	Some light grits, permanent brown 2 core, burnt umber 3 surface. See Pl. 91:8 for photograph.	LB I
2	P 279	Bowl	Intact, some light grits, well fired, burnt umber 3 surface. See Pl. 91:9 for photograph.	LB I
3	P 280	Bowl	Same as No. 1 except for burnt umber 3 core. See Pl. 91:10 for photograph.	LB I
4	P 283	Bowl	Same as No. 1. See Pl. 91:11 for photograph.	LB I
5	3612	Milk bowl handle	Same as No. 8	LB
6	P 272	Bowl	Same as No. 1. See Pl. 91:12 for photograph.	LB I
7	P 281	Bowl	Intact; same as No. 1 except for burnt umber 3 core. See Pl. 91:14 for photograph.	LB II
8	3610	Milk bowl	D. .22, fine ware, some minute light grits, well made, well fired, roman sepia 3 core, burnt umber 2 surface, horizontal burnishing, handmade; Cypriote	LB
9	3613	Milk bowl	D. .15, fine ware, few minute light grits, well made, davy's gray 1 core, davy's gray 3 slip, roman sepia 2 decoration, handmade; Cypriote	LB
10	P 353	Jar	Burnt umber 2. See Pl. 91:1 for photograph.	LB I
11	P 268	Bilbil	Same as No. 12 except for incised and davy's gray 3 decoration	LB
12	P 285	Bilbil	Fine ware, some minute mixed grits, well made, well fired, blue-black 3 core, brown ocher 2 surface, blue-black 2 wash outside and over rim, raised decoration, handmade; Cypriote. See Pl. 91:6 for photograph.	LB
13	3492	Bilbil	Same as No. 12	LB
14	3605	Flask	Fine ware, well fired, blue-black 3 core, burnt umber 2 surface, handmade; Cypriote base-ring ware	LB
15	P 354	Jug	Burnt umber 2	LB II
16	P 287	Jug	Some dark grits, poorly made, well fired, permanent brown 3, vertical shaving. See Pl. 91:7 for photograph.	LB II
17	P 277	Lamp	Some light grits, burnt umber 3	LB I
	P 278	Lamp	Same type as No. 17 except for sepia 3 core	LB I
18	P 276	Lamp	Some light grits, blue-black 3 core, burnt umber 3 surface. See Pl. 91:5 for photograph.	LB I
TOMB 877 A 2				
19	P 2994	Jug	Same as No. 21 except for incised decoration (see p. 148). See Pl. 91:15 for photograph.	MB I
20	P 2993	Jug	Same as No. 21 except for lighter wash (see p. 148). See Pl. 91:16 for photograph.	MB I
21	P 2941	Jug	Many minute mixed grits, brown ocher 3, light red 1 wash outside and over rim, handmade (see p. 148). See Pl. 91:17 for photograph.	MB I
22	P 2991	Jug	Same as No. 21 except for permanent brown 3 core and lighter wash	MB I
23	P 2992	Jug	Same as No. 21 except for blue-black 3 core	MB I
24	P 2939	Jug	Same as No. 21. See Pl. 91:18 for photograph.	MB I
25	P 2929	Jug	Intact; same as No. 21 except for lighter wash	MB I
26	P 2989	Cup	Fine ware, many light grits, well made, well fired, blue-black 3, naples yellow 3 decoration (see p. 148). See Pl. 92:3 for photograph.	MB I
27	P 2988	Cup	Fine ware, many light grits, well made, well fired, indian red 3 core and inside surface, blue-black 3 and indian red 3 outside surface, naples yellow 3 decoration (see p. 148). See Pl. 92:2 for photograph.	MB I
28	P 2930	"Teapot"	Complete; same as No. 26. See Pl. 91:22 for photograph.	MB I
29	P 2934	"Teapot"	Intact; same as No. 26 except for reddish surface (see p. 148)	MB I
30	P 2940	"Teapot"	Same as No. 26. See Pl. 91:25 for photograph.	MB I
31	P 2932	"Teapot"	Same as No. 27 except for reddish outside surface; badly warped. See Pl. 91:23 for photograph.	MB I
32	P 2938	"Teapot"	Intact; same as No. 27 except for reddish outside surface. See Pl. 92:1 for photograph.	MB I
33	P 2990	"Teapot"	Same as No. 27 except for reddish outside surface. See Pl. 91:26 for photograph.	MB I
34	P 2937	"Teapot"	Same as No. 26 except for indian red 3 core and no decoration	MB I
35	P 2931	"Teapot"	Same as No. 26 except for no decoration	MB I

TOMB 217 C

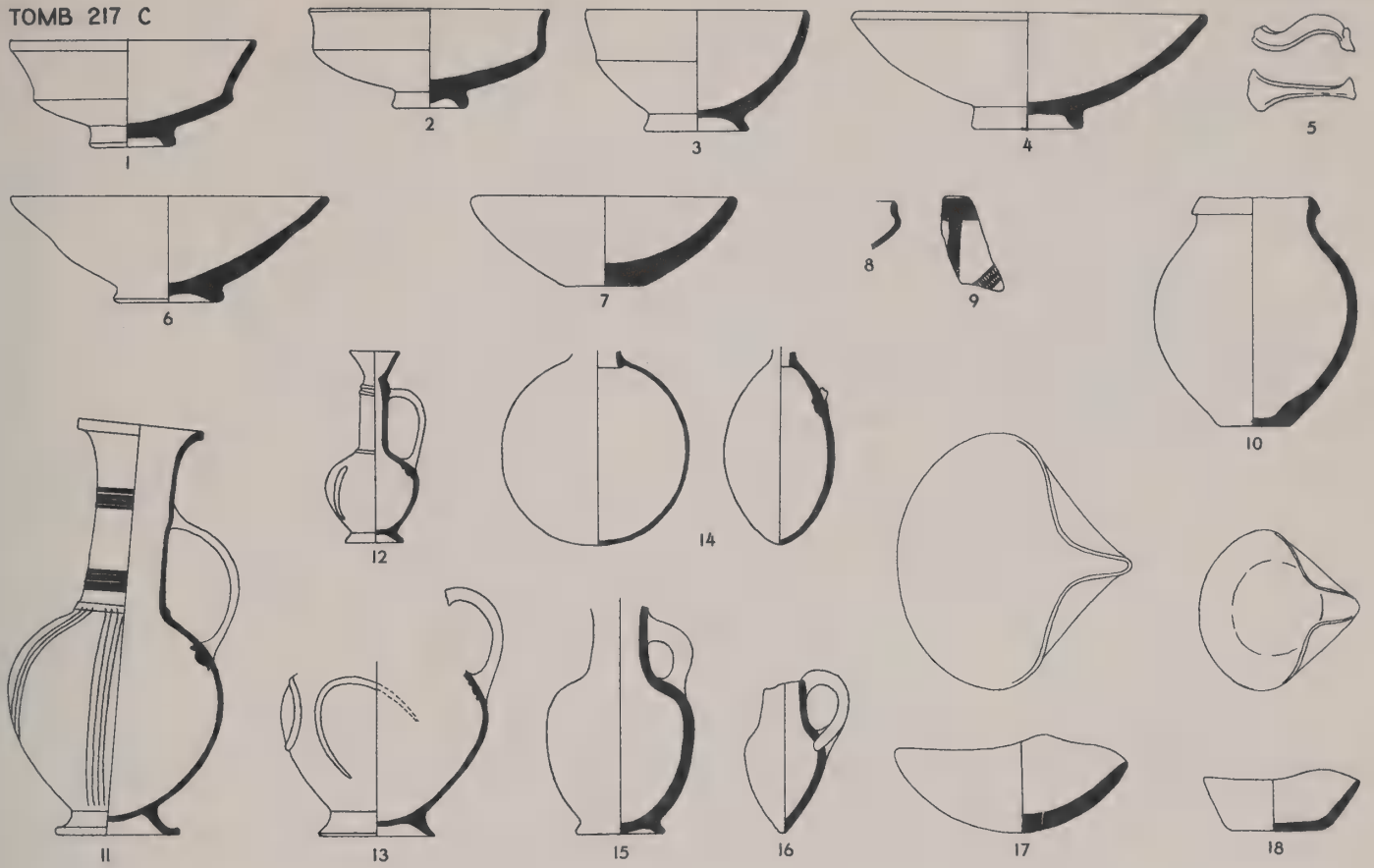

TOMB 877 A 2

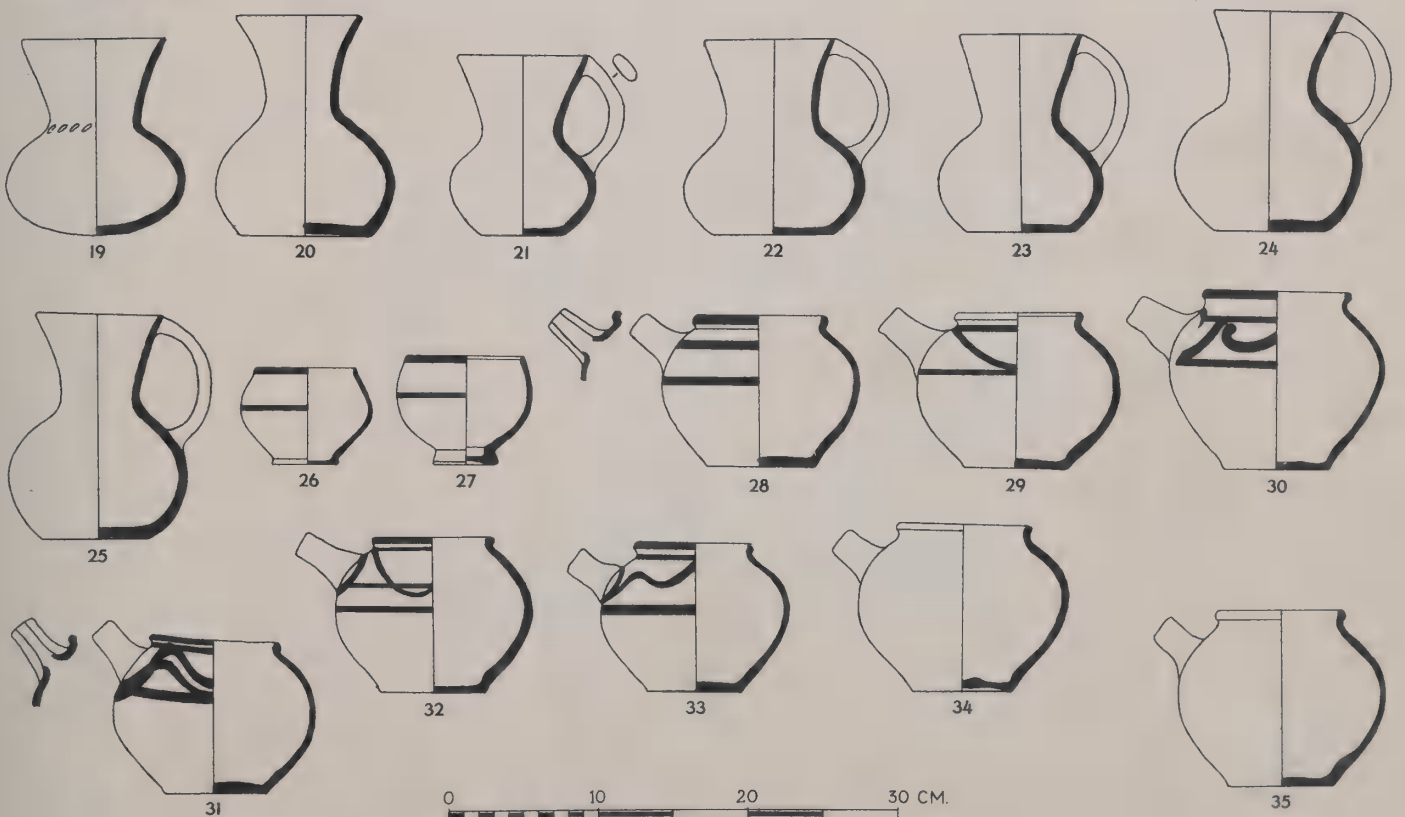

No.	Field No.	Designation	Description	Date
TOMB 877 A 2				
1	P 2936	"Teapot"	Intact, fine ware, many light grits, well made, well fired, blue-black 3, naples yellow 3 decoration. See Pl. 91:24 for photograph.	MB I
2	P 2943	"Teapot"	Many minute mixed grits, naples yellow 2, handmade. See Pl. 91:21 for photograph.	MB I
3	P 2935	"Teapot"	Many minute mixed grits, naples yellow 1, handmade	MB I
4	P 2933	"Teapot"	Many mixed grits, well fired, brown ocher 2, brown ocher 1 wash outside, handmade. See Pl. 91:20 for photograph.	MB I
5	P 2927	Jug	Many minute mixed grits, permanent brown 3 core, brown ocher 2 surface, handmade. See Pl. 91:19 for photograph.	MB I
6	P 2928	Jar	Many mixed grits, poorly made, well fired, permanent yellow 3, incised decoration, folded ledge handles, handmade (see p. 36); warped. See Pl. 91:27 for photograph.	MB I
	P 2942	Jar	Same shape as No. 6, many minute mixed grits, burnt umber 3 core, naples yellow 2 surface, folded ledge handles, handmade	MB I
TOMB 877 B 2				
7	P 2961	"Teapot"	Fine ware, many mixed grits, well made, well fired, indian red 3, naples yellow 2 decoration. See Pl. 93:1 for photograph.	MB I
8	P 2997	Jug	Many minute mixed grits, brown ocher 3, light red 1 wash outside and over rim, handmade. See Pl. 93:2 for photograph.	MB I
9	P 2996	Jug	Many minute mixed grits, roman sepia 3 core, naples yellow 2 inside surface, brown ocher 1 wash outside and over rim, handmade	MB I
TOMB 877 C 2				
10	P 3010	Lamp	Many light grits, chiefly permanent brown 3 core, brown ocher 3 surface (see p. 149)	MB I
11	P 2972	Lamp	Intact, many mixed grits, well fired, brown ocher 3 surface (see p. 149). See Pl. 93:6 for photograph.	MB I
12	P 2965	"Teapot"	Fine ware, many minute mixed grits, well made, well fired, blue-black 3 core, light red 3 to naples yellow 2 surface, naples yellow 3 decoration. See Pl. 93:3 for photograph.	MB I
13	P 2960	"Teapot"	Same as No. 12 except for indian red 3 core and surface. See Pl. 93:5 for photograph.	MB I
14	P 2967	"Teapot"	Many minute light grits, burnt umber 3, handmade (see p. 148). See Pl. 93:4 for photograph.	MB I
15	P 2962	Jug	Many minute mixed grits, permanent brown 3 core, naples yellow 2 surface, handmade	MB I
16	P 2974	Jug	Many minute light grits, brown ocher 3, light red 1 wash outside and over rim, handmade	MB I
TOMB 877 A FILL				
17	P 2897	Smelting-brazier?	Blue-black 3 core, brown ocher 2 surface, spaced horizontal burnishing. See Pl. 93:7 for photograph (cf. Bliss and Macalister, <i>Excavations in Palestine</i> , pp. 99 f. and Fig. 38).	LB II
18	P 2896	Bowl	Many light grits, blue-black 3 core, burnt umber 2 surface, burnt umber 1 wash	LB II
TOMB 877 A 1				
19	P 2924	Jug	Brown ocher 2. See Pl. 93:14 for photograph.	LB II
20	P 2923	Jug	Roman sepia 2 core, brown ocher 2 surface	LB II
21	P 2911	Jug	Brown ocher 2, indian red 3 decoration. See Pl. 93:11 for photograph.	LB II
22	P 2985	Jar	Same as No. 21 (see p. 157). See Pl. 93:12 for photograph.	LB II
23	P 2904	Jar	Intact, well fired, naples yellow 2 surface, decoration faded to vandyke brown 3 (see p. 155). See Pl. 93:13 for photograph.	LB II
24	P 2925	Jug	Intact, brown ocher 3 surface. See Pl. 93:19 for photograph.	LB II

TOMB 877 A 2

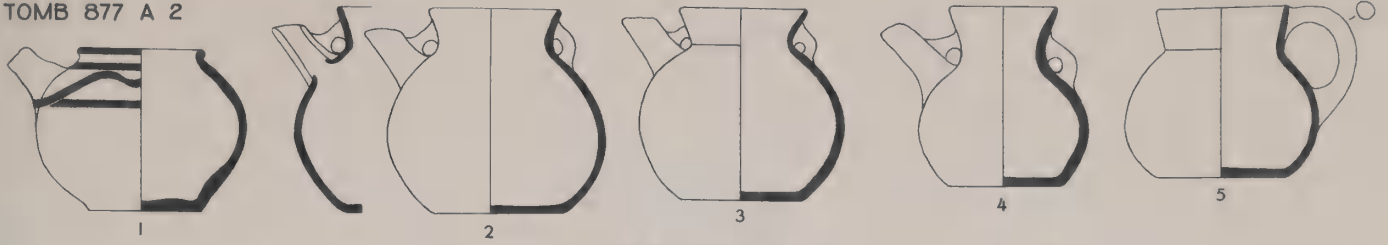

TOMB 877 B 2

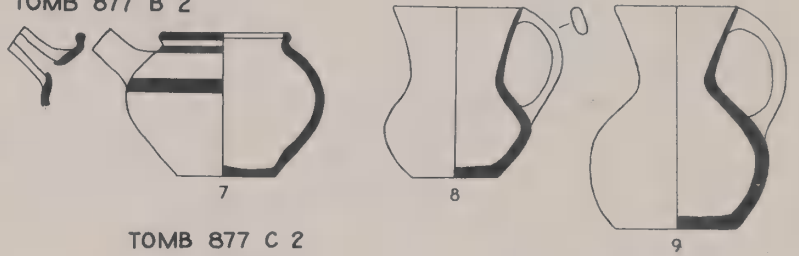

TOMB 877 C 2

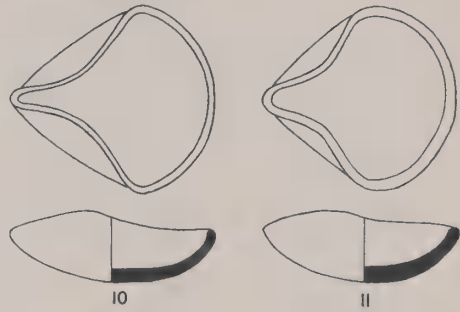

TOMB 877 C 2

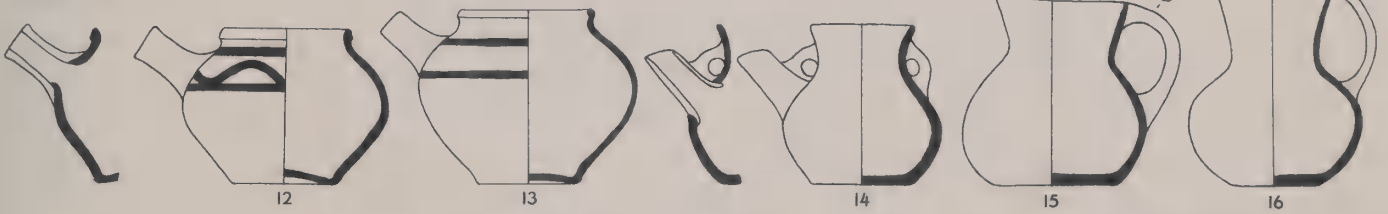

TOMB- 877 A 1

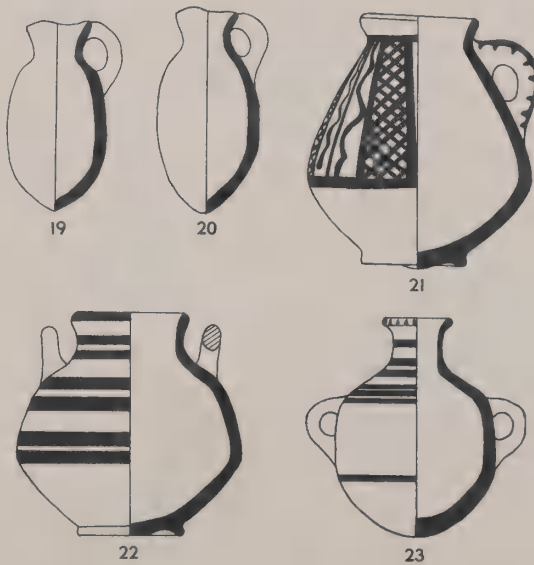

TOMB 877 A FILL

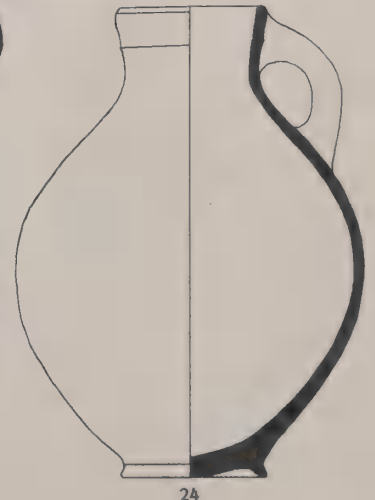
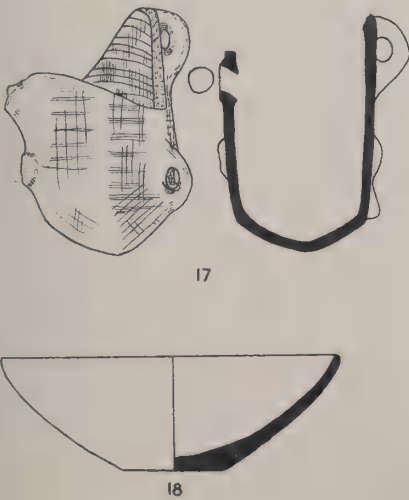

No.	Field No.	Designation	Description
TOMB 877 A 1			
1	P 2907	Bowl	Intact, brown ocher 2 slip
	P 2905 P 2916 P 2919 P 2982	Bowls	Same type as No. 1; traces of burning inside of P 2982 (see Fig. 23); LB II
2	P 2912	Bowl	Intact, brown ocher 2 surface
3	P 2981	Bowl	Same as No. 2 except for large grits and blue-black 3 core
	P 2908	Bowl	Same shape as No. 3, intact, brown ocher 3 surface; LB II
4	P 2913	Bowl	Intact; same as No. 2
5	P 2983	Bowl	Brown ocher 3
6	P 2926	Bowl	Some large mixed grits, poorly made, blue-black 3 core, brown madder 2 surface
	P 2915	Bowl	Same shape as No. 6, large grits, burnt umber 3 core, brown ocher 2 slip; LB II
7	P 2910	Bowl	Intact, many large mixed grits, well made, brown ocher 2 surface, spaced horizontal burnishing outside and on rim. See Pl. 93:9 for photograph.
8	P 2917	Bowl	Intact, many small mixed grits, brown ocher 2 surface
9	P 2986	Bowl	Some large mixed grits, burnt umber 3 core, brown ocher 3 surface, spaced horizontal burnishing outside, light red 2 decoration
10	P 2918	Funnel	Intact, well fired, burnt umber 2 surface. See Pl. 93:15 for photograph.
11	P 2902	Lamp	Well fired, blue-black 3 core, brown ocher 2 surface, blackened by fire. See Pl. 93:16 for photograph.
	P 2903 P 2909	Lamps	Same type as No. 11; LB II
12	P 2921	Jar	Many mixed grits, brown ocher 3. See Pl. 93:20 for photograph.
13	P 2922	Jar	Blue-black 3 core, naples yellow 2 surface, pottery mark
14	P 2920	Jar	Intact; same as No. 12. See Pl. 93:18 for photograph.
TOMB 877 B 1			
15	P 2977	Funnel	Many large light grits, well fired, naples yellow 2 core, naples yellow 1 surface
16	P 2948	Bowl	Many mixed grits, well fired, brown ocher 3 core, naples yellow 2 surface
17	P 2978	Bowl	Intact; same as No. 15
18	P 2958	Bowl	Many mixed grits, poorly made, well fired, brown ocher 3 core, naples yellow 2 to brown ocher 2 surface
19	P 2947	Bowl	Intact, many large light grits, poorly made, well fired, brown ocher 2 surface
20	P 2944	Bowl	Intact; same as No. 19 except for smaller grits
21	P 2951	Bowl	Many large light grits, well fired, blue-black 2 core, brown ocher 2 surface. See Pl. 94:10 for photograph.
22	P 2957	Bowl	Some large light grits, brown ocher 2, thumb handle. See Pl. 94:11 for photograph.
23	P 2950	Bowl	Same as No. 18 except that it is fairly well made
24	P 2956	Bowl	Complete, many light grits, well made, well fired, brown ocher 3 surface, indian red 3 decoration (see p. 157). See Pl. 94:14 for photograph.
	P 2953	Bowl	Same shape as No. 24, chiefly brown ocher 3; LB II

TOMB 877 A I

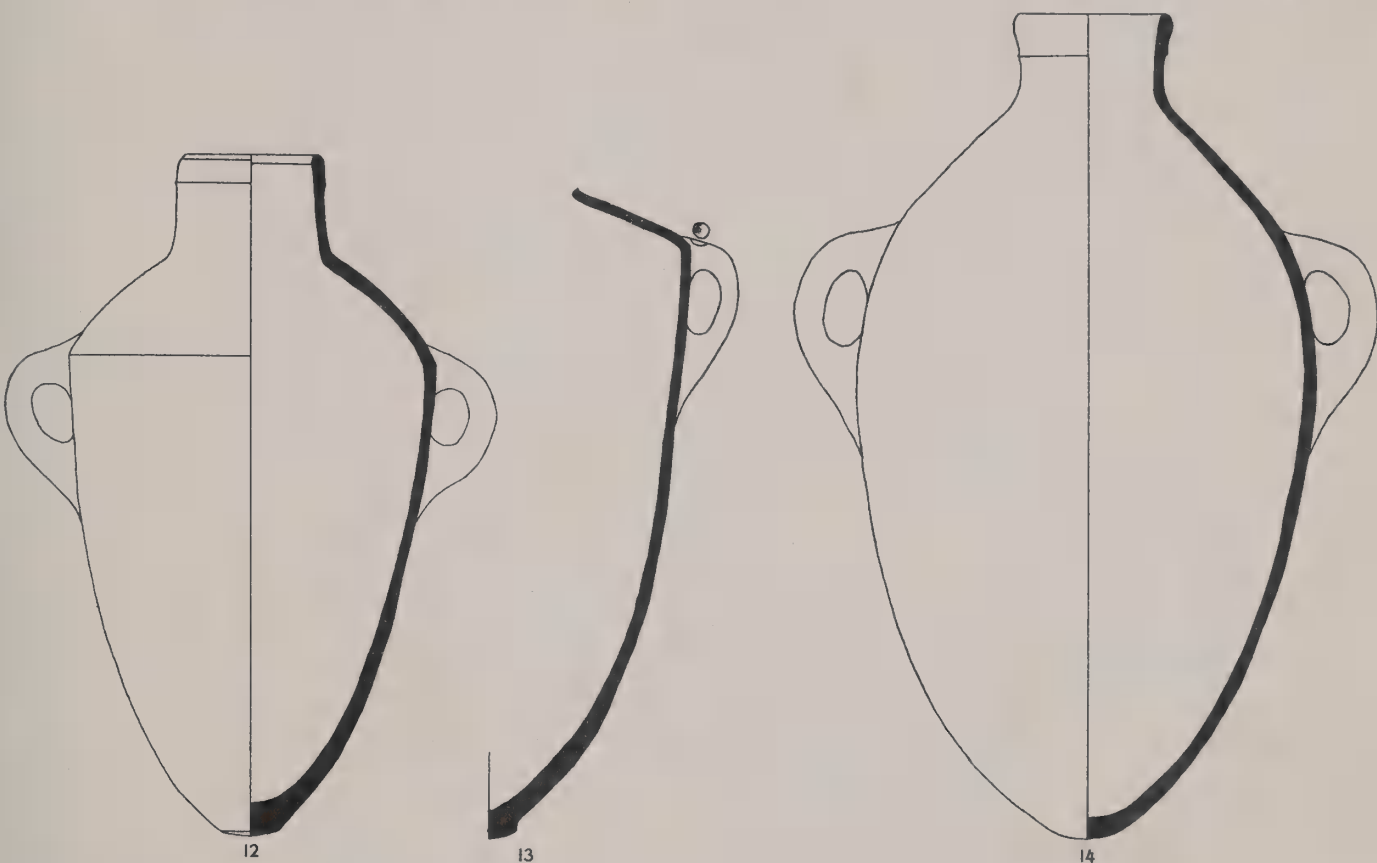
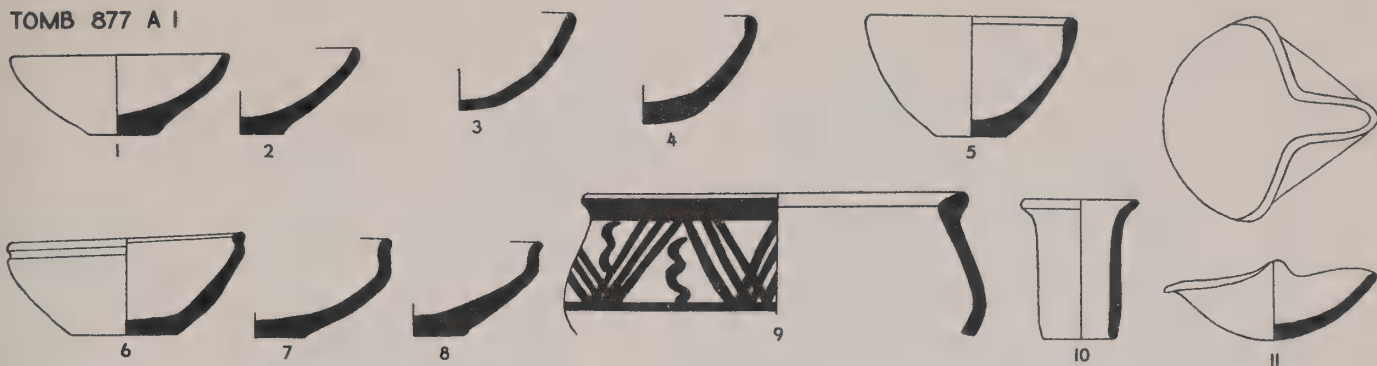

TOMB 877 B I

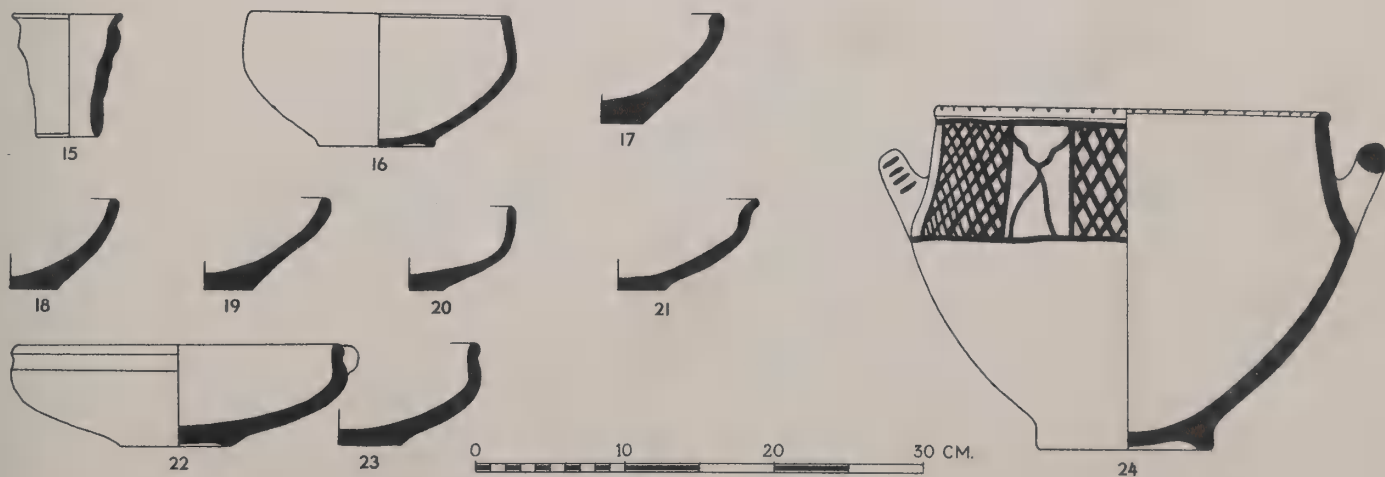

LB II POTTERY FROM TOMB 877 (SEE PP. 33-36). SCALE, 1:5

No.	Field No.	Designation	Description	Date
TOMB 877 B 1				
1	P 2980	Jug	Complete, many mixed grits, brown ocher 2 surface, traces of close vertical burnishing, indian red 3 decoration. See Pl. 94:16 for photograph.	LB II
2	P 2954	Jug	Intact, many mixed grits, well made, well fired, naples yellow 2 to brown ocher 2 surface, spaced vertical burnishing. See Pl. 94:15 for photograph.	LB II
3	P 2946	Jug	Intact, many mixed grits, well fired, brown ocher 3 surface, vertical shaving. See Pl. 94:12 for photograph.	LB II
4	P 2955	Lamp	Complete, well fired, brown ocher 3 surface, lip blackened by fire	LB II
5	P 2952	Jar	Intact, many light grits, well made, well fired, brown ocher 3 surface, indian red 3 decoration (see pp. 155 and 157). See Pl. 94:17 for photograph.	LB II
6	P 2979	Flask	Many light grits, poorly made, well fired, blue-black 2 core, brown ocher 3 surface, indian red 3 decoration	LB II
	P 2945	Flask	Same type as No 6	LB II
7	P 3005	Stirrup cup	Fine ware, few minute mixed grits, well made, brown ocher 3, close horizontal burnishing, indian red 3 decoration; Mycenaean (see p. 157)	LB II
		Sherd	Mycenaean	LB II
TOMB 877 C 1				
8	P 2969	Jug	Same as No. 13. See Pl. 96:11 for photograph.	LB I
9	P 3271	Bowl	Complete, many mixed grits, permanent brown 3 core, brown ocher 3 surface. See Pl. 96:5 for photograph.	LB I
10	P 2975	Bowl	Many large light grits, well fired, blue-black 2 core, brown ocher 2 surface	LB II
11	P 2971	Bowl	Intact, many mixed grits, well fired, brown ocher 2 surface. See Pl. 96:4 for photograph.	LB I
12	P 2964	Bowl	Intact, some large mixed grits, poorly made, well fired, brown ocher 2 surface	LB II
13	P 2976	Jug	Fine ware, many minute mixed grits, well made, well fired, naples yellow 2. See Pl. 96:9 for photograph.	LB I
14	P 2970	Jug	Same as No. 13 except for brown ocher 2 core and surface. See Pl. 96:10 for photograph.	LB I
15	P 2959	Jug	Fine ware, few minute mixed grits, well made, chiefly permanent brown 2 core, roman sepia 3 surface, spaced vertical burnishing. See Pl. 96:6 for photograph.	LB I
16	P 2963	Jug	Some minute mixed grits, chiefly blue-black 3 core, permanent brown 3 surface	LB I
17	P 2973	Jug	Many mixed grits, well fired, brown ocher 2. See Pl. 96:12 for photograph.	LB II
18	P 3312	Jug	Burnt umber 3	LB II
19	P 3270	Jug	Many mixed grits, brown ocher 2, roman sepia 1 and indian red 1 decoration	LB I
20	P 2968	Jug	Few minute mixed grits, lightly fired, near blue-black 3 core, brown ocher 3 surface	LB I
21	P 3007	Jug	Fine ware, some minute light grits, well fired, blue-black 3 core, brown ocher 1 surface, traces of darker wash, vertically ribbed decoration, handmade; Cypriote <i>bucchero</i> ware. See Pl. 96:8 for photograph.	LB II
22	P 2966	Jug	Same as No. 19 except for decoration faded to roman sepia 2 and light red 3. See Pl. 96:7 for photograph.	LB I
23	P 3008	Jug	Same as No. 16	LB II
24	P 3009	Jar	Many large light grits, naples yellow 2 core, naples yellow 2 to brown ocher 2 surface	LB II

TOMB 877 B I

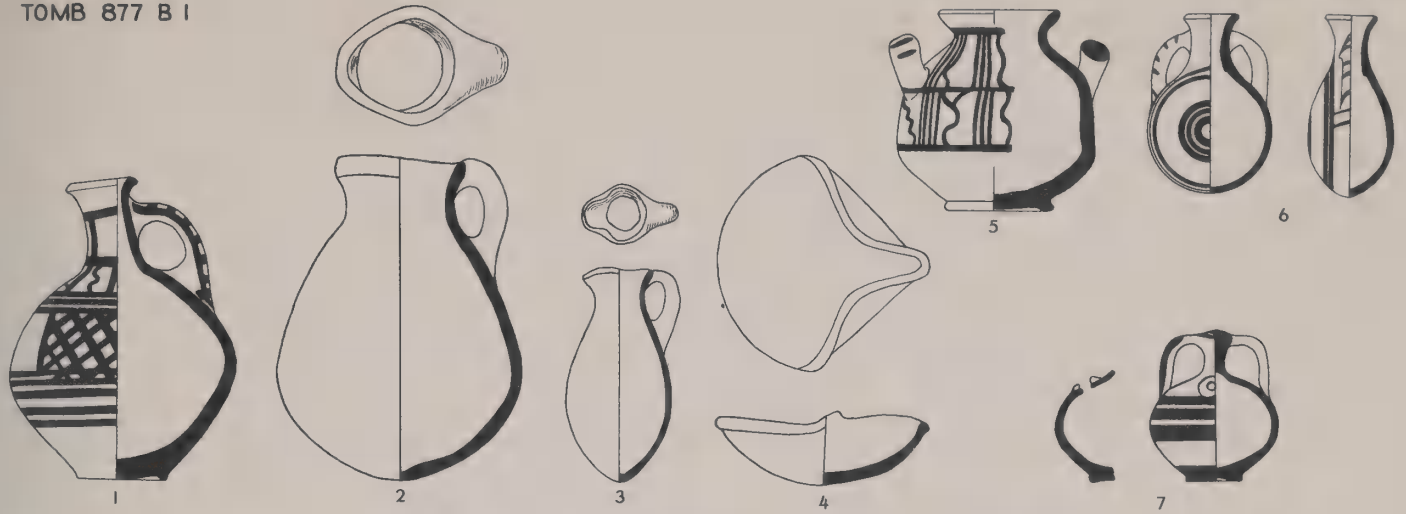

TOMB 877 C I

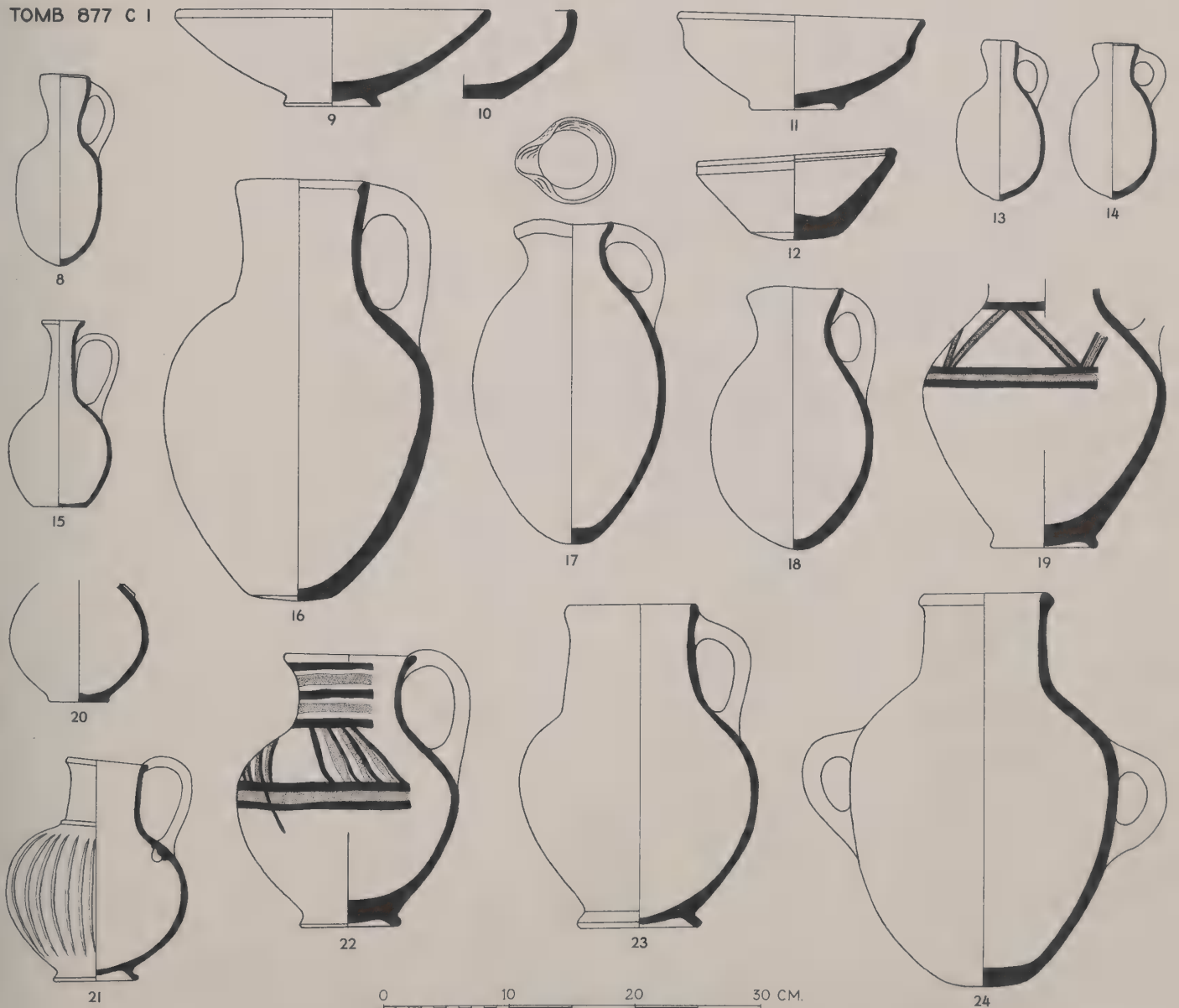

0 10 20 30 CM.

LB POTTERY FROM TOMB 877 (SEE PP. 33-36). SCALE, 1:5

No.	Field No.	Designation	Description	Date
TOMB 989 A 2				
1	P 3304	"Teapot"	Fine ware, many minute light grits, well made, well fired, indian red 3 core, blue-black 3 surface, naples yellow 3 decoration. See Pl. 97:1 for photograph.	MB I
2	P 3305	"Teapot"	Same as No. 1	MB I
3	P 3394	Jar	Many minute mixed grits, well fired, permanent yellow 3, folded ledge handles, handmade	MB I
TOMB 989 B 2				
4	P 3382	Jug	Many minute mixed grits, brown ocher 2, light red 1 wash outside and over rim, handmade	MB I
5	P 3381	Jug	Same as No. 4	MB I
TOMB 989 C 2				
6	P 3172	"Teapot"	Intact; same as No. 1. See Pl. 97:2 for photograph.	MB I
7	P 3171	"Teapot"	Same as No. 1 except for blue-black 3 core. See Pl. 97:3 for photograph.	MB I
TOMB 989 D 2				
8	P 3220	"Teapot"	Intact; same as No. 1. See Pl. 97:4 for photograph.	MB I
9	P 3221	"Teapot"	Same as No. 1. See Pl. 97:5 for photograph.	MB I
10	P 3393	Jar	Same as No. 3 except that it is wheelmade	MB I
TOMB 989 SHAFT				
11	P 3358	Bowl	Many light grits, blue-black 3 core, naples yellow 2 surface	LB II
12	P 3361	Jar	Few large mixed grits, naples yellow 2	LB II
13	P 3356	Jug	Many light grits, blue-black 3 core, naples yellow 2 to brown ocher 2 surface	LB II
TOMB 989 A 1				
14	P 3205	Bowl	Many light grits, blue-black 3 core, brown ocher 2 surface, thumb handle (see p. 155)	LB II
15	P 3301	Bowl	Many large light grits, blue-black 3 core, burnt umber 3 surface, thumb handle	LB II
16	P 3337	Bowl	Same as No. 14 except for brown ocher 3 core (see p. 155)	LB II

TOMB 989 A 2

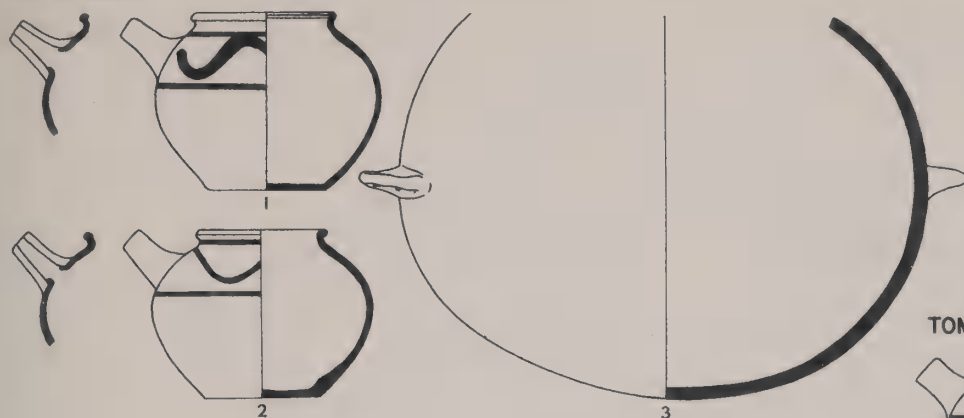

TOMB 989 B 2

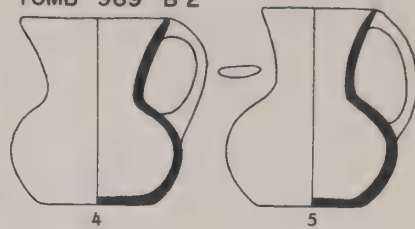

TOMB 989 C 2

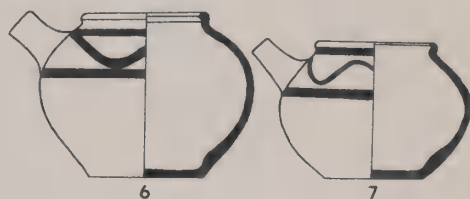

TOMB 989 D 2



TOMB 989 SHAFT

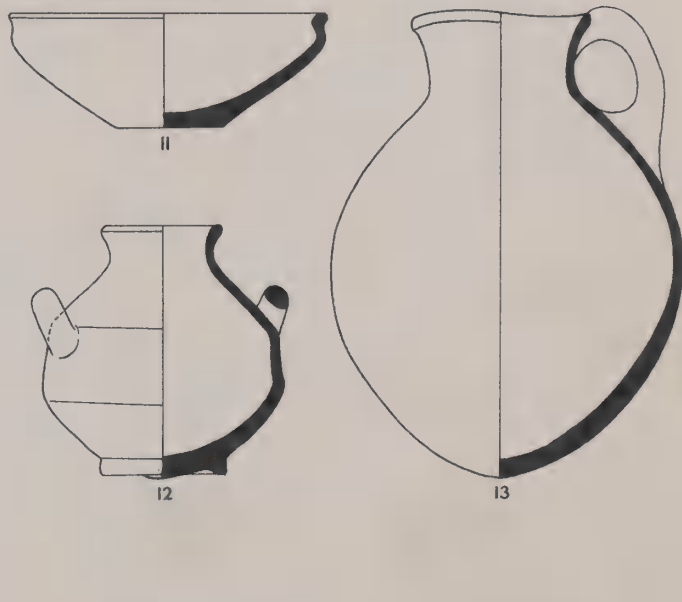

TOMB 989 A 1

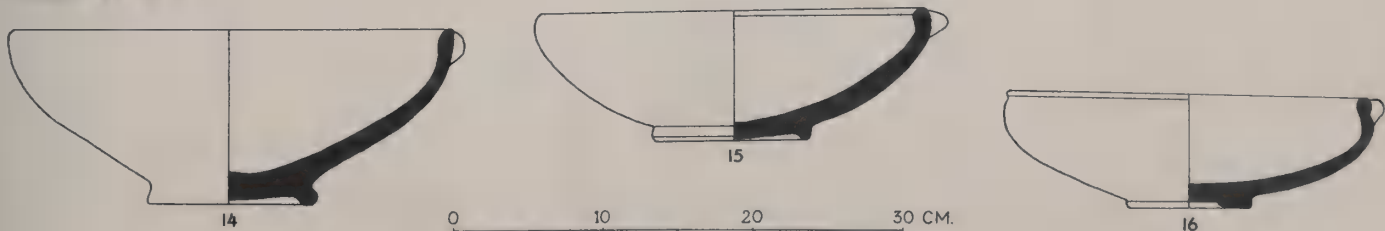

No.	Field No.	Designation	Description	Date
1	P 3156	Bowl	Many mixed grits, well fired, brown ocher 2	LB II
2	P 3153	Bowl	Many mixed grits, blue-black 3 core, brown ocher 3 surface, thumb handle	LB II
	P 3222	Bowl	Same type as No. 2 except for large light grits and no handle	LB II
3	P 3298	Bowl	Many predominantly light grits, brown ocher 2; badly warped	LB II
	P 3168	Bowls	Same type as No. 3 with minor variations in grits and core (see Fig. 38)	LB II
	P 3339			
	P 3346-47			
	P 3353			
	P 3370			
	P 3375			
	P 3377			
4	P 3294	Bowl	Brown ocher 2	LB II
	P 3167	Bowls	Same type as No. 4 with minor variations in grits and surface (see Figs. 38-39)	LB II
	P 3203-4			
	P 3223			
	P 3324			
5	P 3200	Bowl	Brown ocher 2 (see p. 154)	LB II
6	P 3318	Bowl	Many light grits, naples yellow 2; intrusive(?)	LB I
7	P 3374	Cooking bowl	Some minute mixed grits, roman sepia 2 core, burnt umber 1 surface (see p. 155)	LB II
8	P 3157	Funnel	Many light grits, well fired, burnt umber 3	LB II
9	P 3376	Chalice	Few minute mixed grits, roman sepia 3 core, brown ocher 2 surface(see p. 154)	LB II
10	P 3296	Chalice	Some light grits, brown ocher 2 (see p. 154). See Pl. 98:1 for photograph.	LB II
11	P 3378	Jug	Many minute mixed grits, well fired, permanent brown 2 core, burnt umber 2 inside surface, permanent yellow 3 slip outside, roman sepia 2 decoration; intrusive(?). See Pl. 98:2 for photograph. Cf. Pl. 147:6 for decoration.	LB I
12	P 3395	Jug	Fine ware, few dark grits, roman sepia 3 core, naples yellow 3 surface, purple madder 1 decoration; intrusive(?). Cf. Pl. 48:3 for decoration.	LB I
13	P 3166	Jug	Well made, brown ocher 2, indian red 2 decoration. See Pl. 98:4 for photograph.	LB II
14	P 3170	Jug	Brown ocher 1. See Pl. 98:5 for photograph.	LB II
15	P 3322	Jug	Permanent brown 3 core, brown ocher 1 surface	LB II
16	P 3297	Jug	Some minute mixed grits, brown ocher 1, spaced irregular burnishing	LB II
17	P 3150	Jug	Some minute light grits, blue-black 2 core, brown ocher 2 surface, naples yellow 3 decoration, handmade; Cypriote <i>bucchero</i> ware (see p. 158). See Pl. 98:3 for photograph.	LB II
18	P 3320	Jug	Blue-black 3 core, brown ocher 3 surface	LB II
19	P 3323	Jug	Many light grits, permanent brown 3 core, burnt umber 3 surface, indian red 1 decoration; badly warped. See Pl. 97:6 for photograph.	LB II
20	P 3368	Jug	Brown ocher 2 (see p. 155)	LB II
21	P 3206	Jug	Many predominantly light grits, brown ocher 3 (see p. 151). See Pl. 97:7 for photograph.	LB II
22	P 3299	Jug	Brown ocher 2 surface (see p. 155). See Pl. 97:8 for photograph.	LB II
23	P 3302	Jug	Many minute dark grits, naples yellow 3, vertical shaving (see p. 155). See Pl. 97:9 for photograph.	LB II
24	P 3342	Jug	Some light grits, blue-black 2 core, brown ocher 2 surface, spaced vertical burnishing	LB II
25	P 3169	Jug	Intact, many mixed grits, brown ocher 2 surface (see pp. 150 and 155). See Pl. 97:10 for photograph.	LB II
26	P 3218	Jug	Brown ocher 3, wet-smoothed after vertical shaving (see pp. 150 and 155)	LB II
	P 3162 } P 3336 }	Jugs	Same type as No. 26	LB II
27	P 3161	Jug	Intact, brown ocher 3 surface, wet-smoothed after vertical shaving (see pp. 150 and 155). See Pl. 97:13 for photograph.	LB II
	P 3207	Jug	Same type as No. 26 (see Fig. 39)	LB II
28	P 3219	Jug	Many minute light grits, poorly made, burnt umber 2 (see pp. 150 and 155). See Pl. 97:12 for photograph.	LB II

TOMB 989 A1

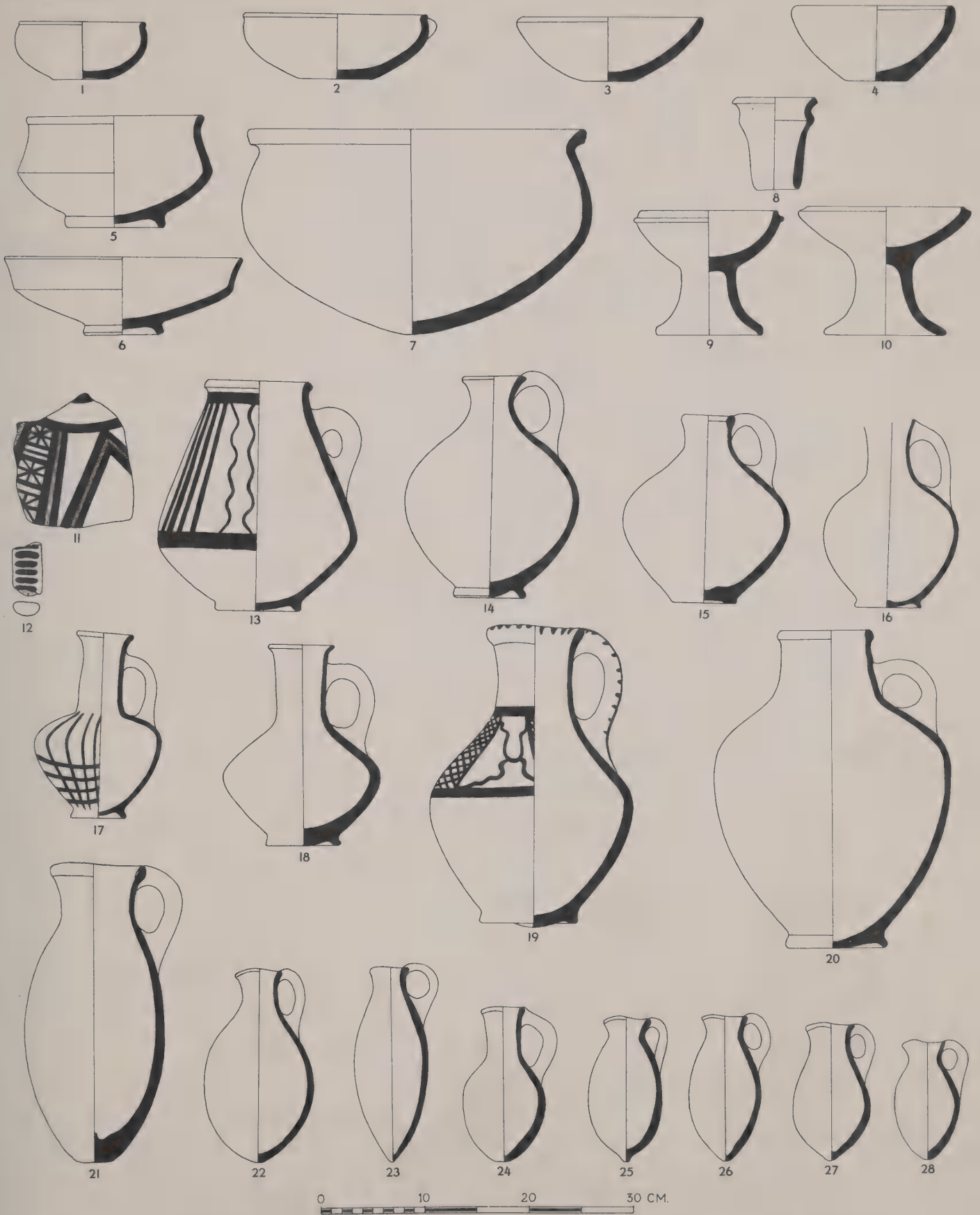

LB POTTERY FROM TOMB 989 A 1 (SEE P. 40). SCALE, 1:5

No.	Field No.	Designation	Description	Date
1	P 3201	Jug	Many mixed grits, well fired, brown ocher 2 (see p. 155)	LB II
2	P 3344	Jug	Many mixed grits, well fired, brown ocher 3 (see p. 155). See Pl. 97:11 for photograph.	LB II
3	P 3202	Jug	Intact, many predominantly light grits, well made, brown ocher 2 surface (see p. 155). See Pl. 97:15 for photograph.	LB II
4	P 3373	Jug	Blue-black 3 core, brown ocher 2 surface (see p. 155)	LB II
5	P 3392	Jug	Many large light grits, naples yellow 2 (see p. 155)	LB II
6	P 3208	Lamp	Brown ocher 3. See Pl. 97:14 for photograph.	LB II
	P 3295 } P 3303 } P 3340 }	Lamps	Same shape as No. 6, blue-black 2 core, darker surface	LB II
7	P 3325	Lamp	Same as No. 6; intrusive(?)	LB I
8	P 3369	Lamp	Blue-black 2 core, brown ocher 2 surface; intrusive(?)	LB I
9	P 3327	Stirrup cup	Fine ware, few minute light grits, well made, well fired, naples yellow 2, close burnishing, indian red 1 decoration; Mycenaean	LB II
10	P 3326	Stirrup cup	Same as No. 9 except for near vandyke brown 3 decoration	LB II
11	P 3379	Jar	Many minute mixed grits, well fired, permanent brown 2 core, burnt umber 2 inside surface, permanent yellow 3 slip outside, roman sepia 2 decoration; intrusive(?)	LB I
12	P 3155	Jar	Roman sepia 1 core, brown ocher 2 surface (see p. 155). See Pl. 97:16 for photograph.	LB II
13	P 3360	Jar	Many predominantly light grits, well fired, blue-black 2 core, chiefly naples yellow 3 surface (see p. 155). See Pl. 97:17 for photograph.	LB II
	P 3164 } P 3363 } P 3391 }	Jars	Same shape as No. 13, many mixed grits, brown ocher 2 (see Fig. 38)	LB II
14	P 3160	Jar	Well fired, burnt umber 2 core, naples yellow 2 surface (see p. 155). See Pl. 97:18 for photograph.	LB II
	P 3151 } P 3159 } P 3319 } P 3321 } P 3341 } P 3352 }	Jars	Same shape as No. 14, many minute grits, burnt umber 2 or blue-black 3 core, brown ocher 2 or burnt umber 3 surface	LB II

TOMB 989 A1

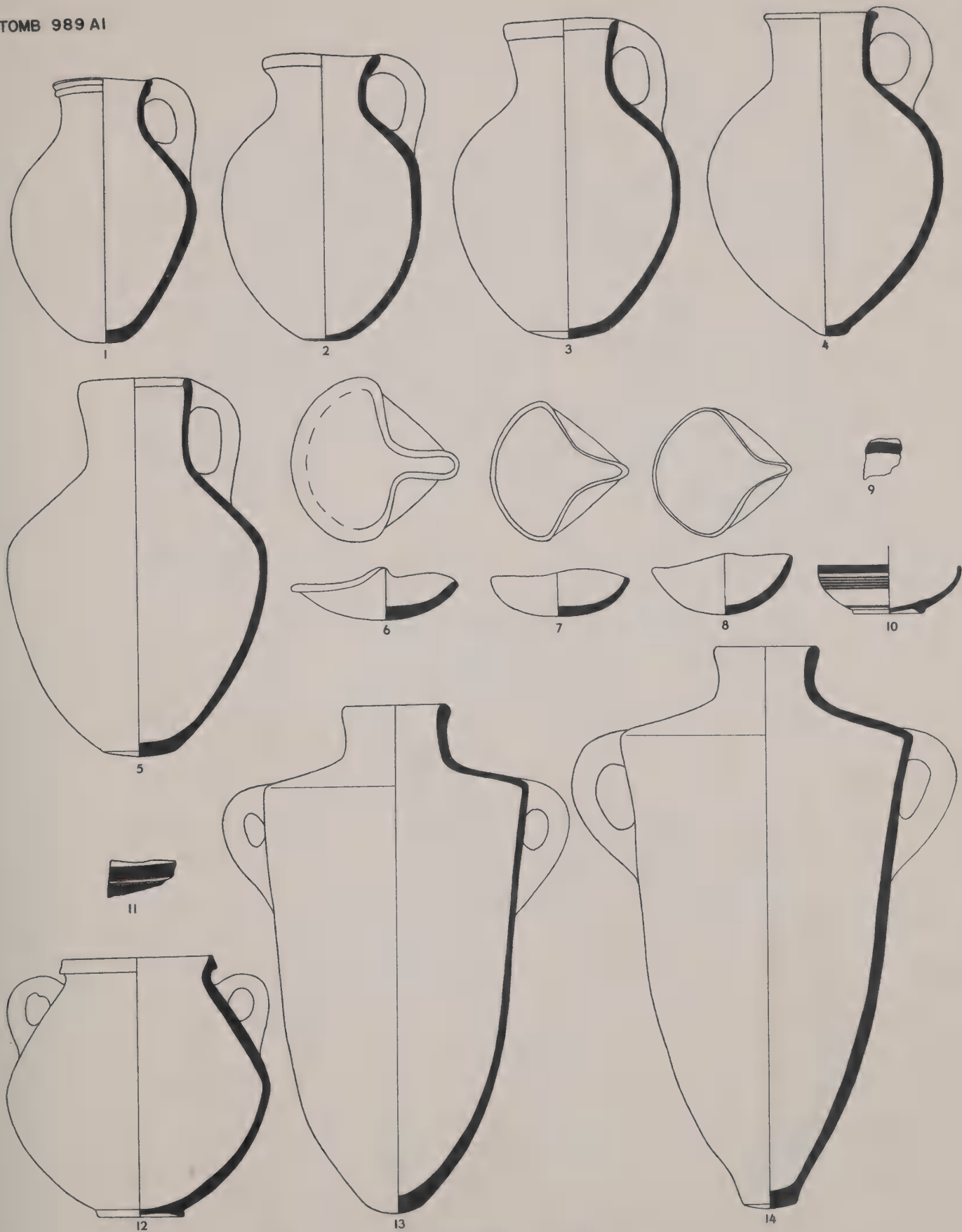

LB POTTERY FROM TOMB 989 A 1 (SEE P. 40). SCALE, 1:5

No.	Field No.	Description
TOMB 989 A 1		
1	P 3300	Brown ocher 1, indian red 1 decoration (see p. 155). See Pl. 98:7 for photograph.
	P 3343	Same type as No. 1; LB II
2	P 3154	Many mixed grits, roman sepia 2 core, brown ocher 2 surface (see p. 155)
	P 3152	Same type as No. 2 with minor variations in grits and core (see Fig. 38); LB II
	P 3158	
	P 3163	
	P 3165	
	P 3355	
	P 3357	
	P 3365	
	P 3367	
3	P 3338	Many mixed grits, chiefly blue-black 3 core, brown ocher 2 surface (see p. 155)
TOMB 989 B 1		
4	P 3313	Many minute mixed grits and few large grits, well fired, burnt umber 1 core, naples yellow 2 surface. See Pl. 98:15 for photograph.

TOMB 989 A1

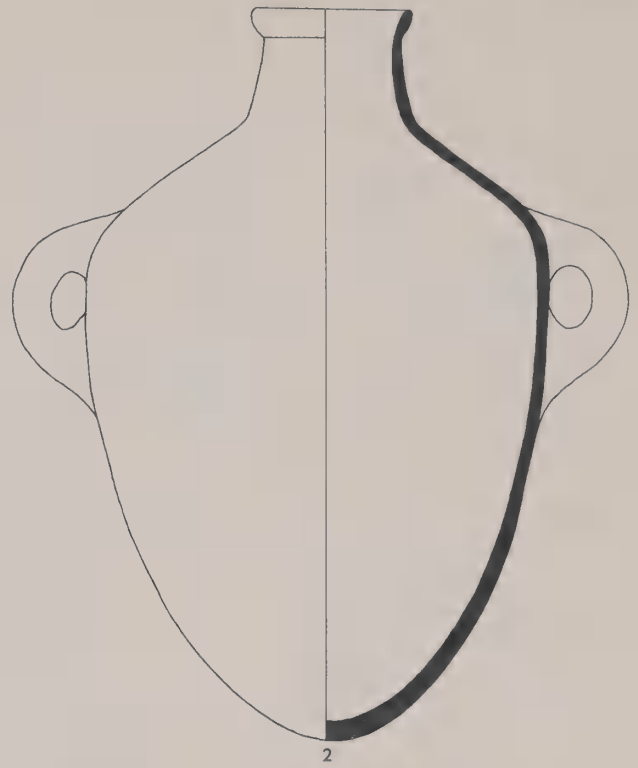
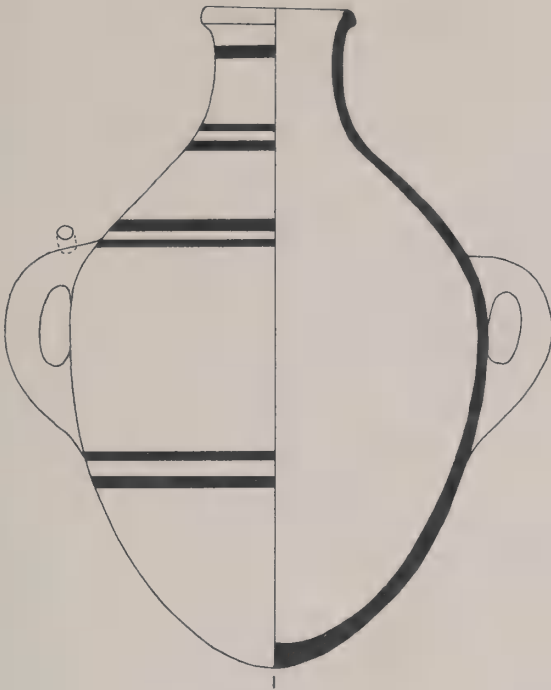

TOMB 989 B1

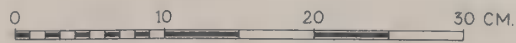
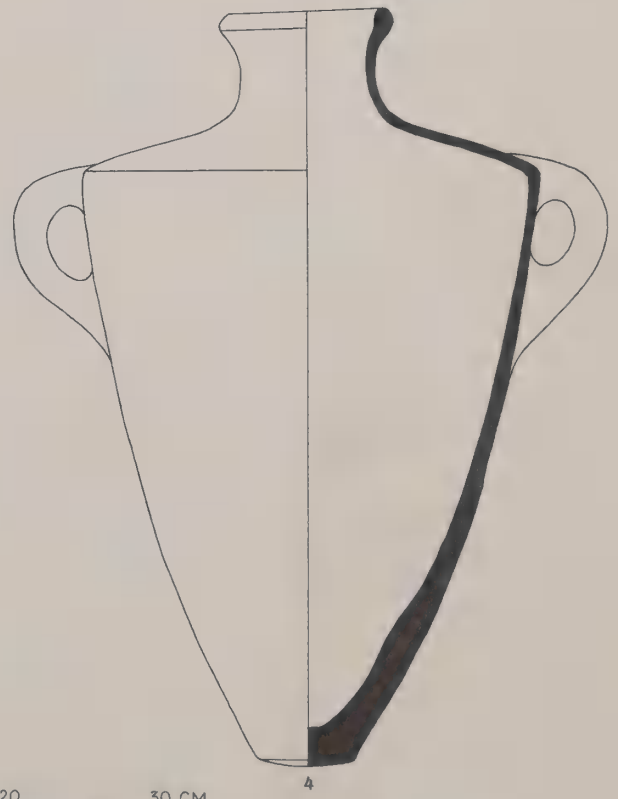
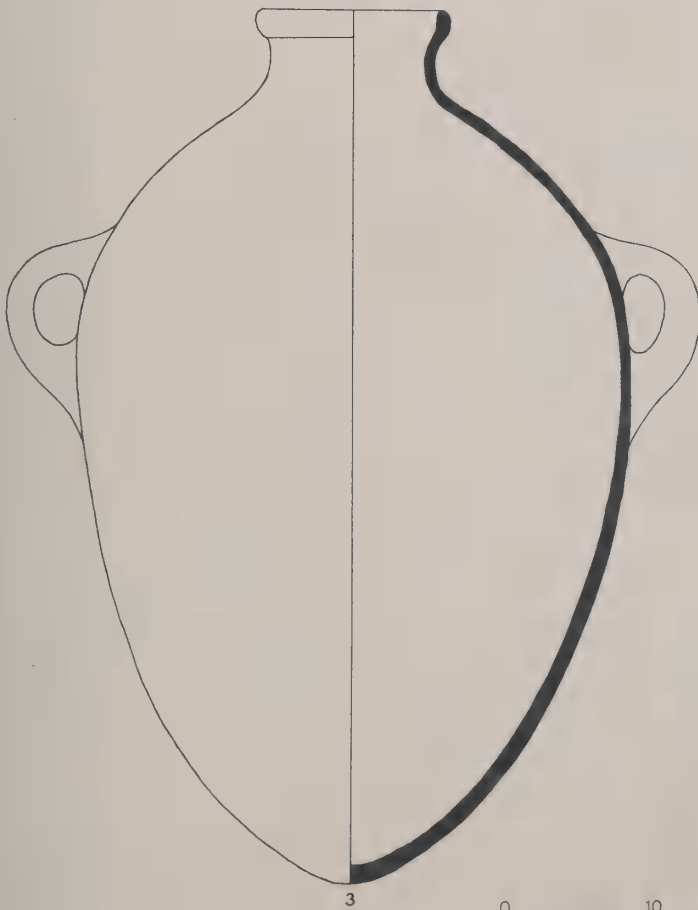

LB II POTTERY JARS FROM TOMB 989 (SEE P. 40). SCALE, 1:5

No.	Field No.	Designation	Description	Date			
TOMB 989 B 1							
1	P 3307	Bowl	Blue-black 3 core, brown ocher 2 surface. See Pl. 98:13 for photograph.	LB I			
2	P 3383	Flask	T. .080, some minute mixed grits, blue-black 3 core, brown ocher 2 surface, traces of burnishing and indian red 3 decoration	LB II			
3	P 3362	Bowl	Brown ocher 2	LB I			
4	P 3372	Bowl	Blue-black 2 core, brown ocher 2 surface	LB I			
5	P 3359	Lamp	Many light grits, permanent brown 2 core, chiefly burnt umber 3 surface. See Pl. 98:18 for photograph.	LB II			
6	P 3351	Jug	Brown ocher 2. See Pl. 98:16 for photograph.	LB II			
7	P 3380	Jug	Blue-black 3 core, brown ocher 1 surface, spaced horizontal burnishing, indian red 3 decoration	LB II			
8	P 3306	Jug	Brown ocher 2, spaced horizontal burnishing, light red 1 decoration. See Pl. 98:17 for photograph.	LB II			
TOMB 989 C 1							
9	P 3177	Bowl	Intact, many predominantly light grits, well fired, brown ocher 2 surface. See Pl. 99:7 for photograph.	LB II			
	P 3178 P 3184-85 P 3190 P 3389	Bowls	Same type as No. 9 except for minor variations in grits and naples yellow 2 surface (see Figs. 40-41)	LB II			
10	P 3189				Bowl	Intact, many large light grits, well fired, brown ocher 1 surface; badly warped. See Pl. 99:5 for photograph.	LB II
	P 3001				Bowl	Same type as No. 10 except for some mixed grits and blue-black 2 core	LB II
11	P 3176				Bowl	Blue-black 3 core, brown ocher 2 surface. See Pl. 99:4 for photograph.	LB II
12	P 2999	Bowl	Intact, many predominantly light grits, well fired, brown ocher 2 surface	LB II			
	P 2998 P 3187-88 P 3267-68	Bowls	Same type as No. 12 except for larger grits and some with naples yellow 2 surface (see Fig. 40)	LB II			
13	P 3269				Bowl	Roman sepia 2 core, burnt umber 1 surface, indian red 3 wash inside and over rim	LB II
14	P 3191	Bowl	Intact, well fired, brown ocher 2 surface, thumb handle. See Pl. 99:6 for photograph.	LB II			
15	P 3310	Milk bowl	Some minute light grits, burnt umber 1 core, brown ocher 3 slip, close horizontal burnishing, roman sepia 2 decoration, handmade; Cypriote. See Pl. 99:11 (for photograph) and p. 158.	LB II			
16	P 3175	"Cup and saucer"	Brown ocher 2 (see p. 155). See Pl. 99:10 for photograph.	LB II			
17	P 3186	Chalice	Intact, brown ocher 1 surface. See Pl. 99:9 for photograph.	LB II			
18	P 3194	Jug	Many mixed grits, blue-black 3 core, brown ocher 3 surface (see p. 155). See Pl. 99:13 for photograph.	LB II			
19	P 3311	Jug	Many mixed grits, permanent brown 3 core, brown ocher 2 surface (see p. 155)	LB II			
20	P 3192	Jug	Brown ocher 3, wet-smoothed after vertical shaving. See Pl. 99:19 for photograph.	LB II			
21	P 3180	Jug	Intact, many mixed grits, well fired, brown ocher 2 surface, indian red 2 decoration (see p. 156). See Pl. 99:17 for photograph.	LB II			
22	P 3197	Jug	Intact, many mixed grits, brown ocher 2 surface, traces of indian red 3 wash on rim and handle. See Pl. 99:18 for photograph.	LB II			
23	P 3386	Jug	Many light grits, roman sepia 3 core, brown ocher 3 surface. See Pl. 99:12 for photograph.	LB II			
24	P 3224	Jug	Some minute mixed grits, brown ocher 3, light red 2 decoration; local imitation of Cypriote <i>bucchero</i> ware. See Pl. 99:15 for photograph.	LB II			
25	P 3195	Jug	Some minute mixed grits, blue-black 3 core, chiefly burnt umber 1 surface, naples yellow 3 decoration, handmade; Cypriote <i>bucchero</i> ware (see p. 158). See Pl. 99:16 for photograph.	LB II			

TOMB 989 B I

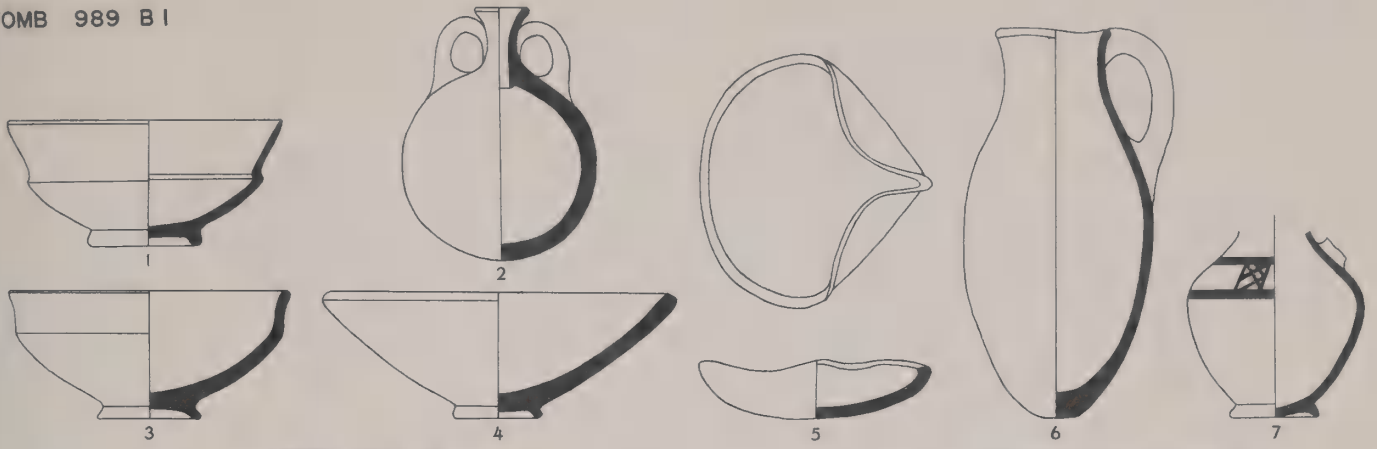

TOMB 989 C I

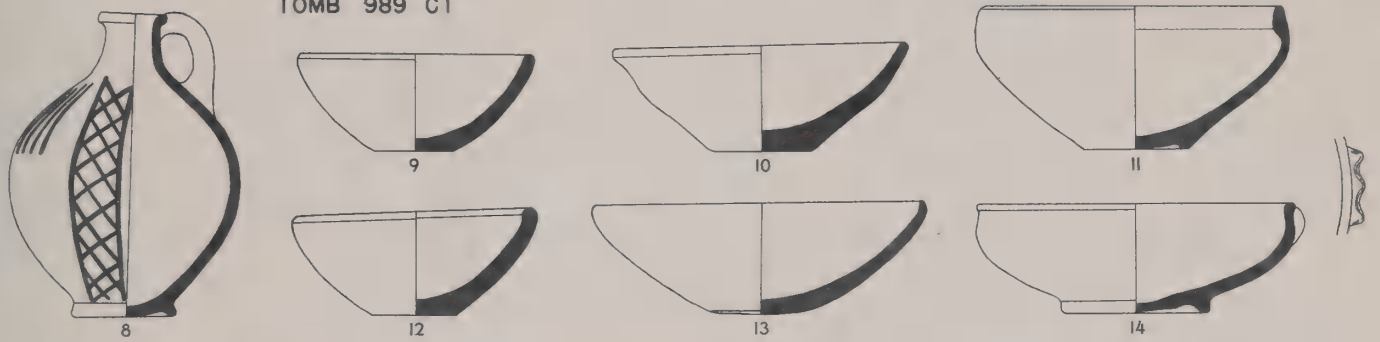

TOMB 989 C I

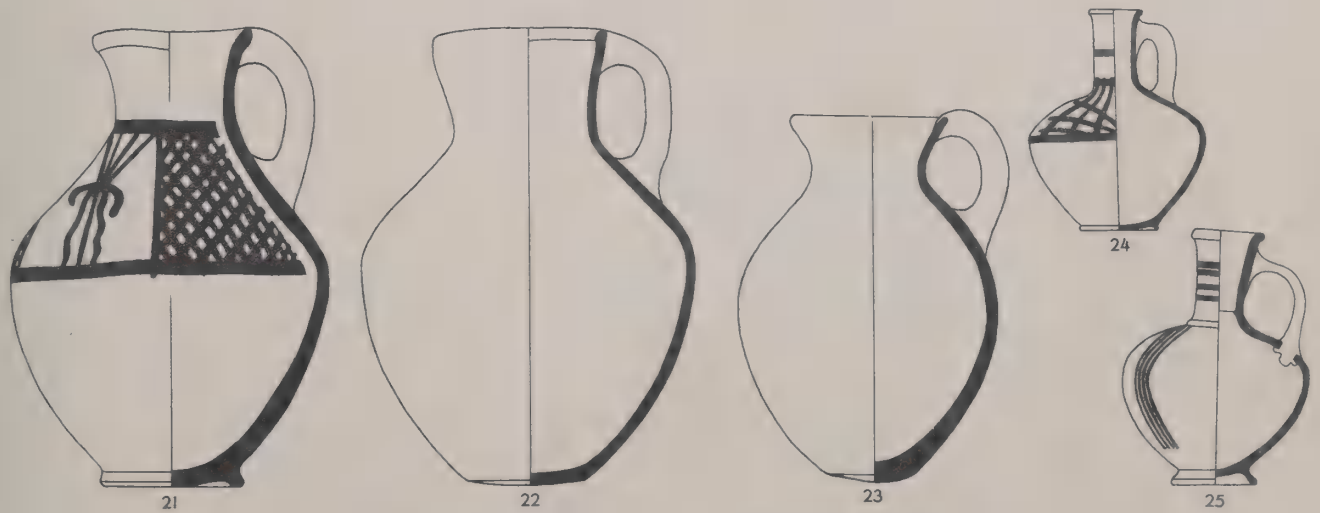
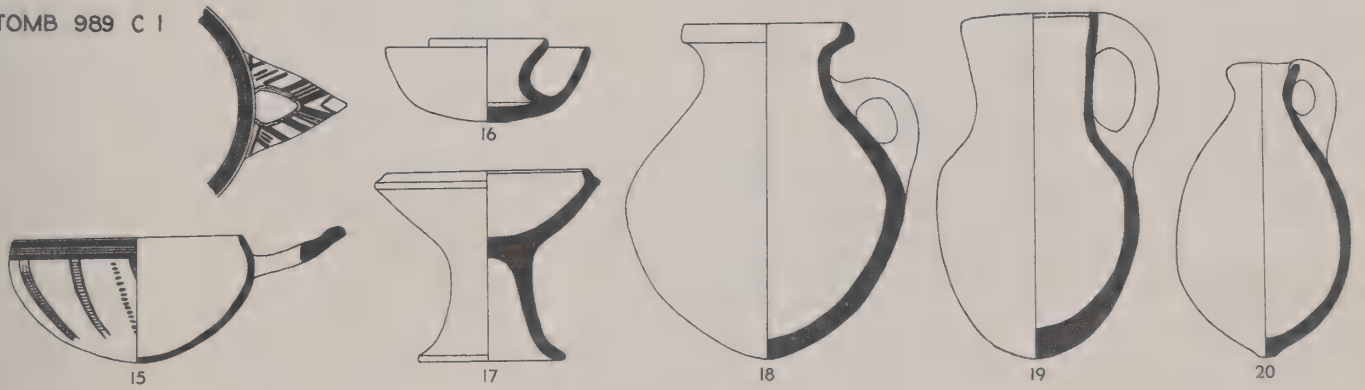

0 10 20 30 CM.

LB POTTERY FROM TOMB 989 (SEE P. 40). SCALE, 1:5

No.	Field No.	Designation	Description	Date
TOMB 989 C 1				
1	P 3173	Jug	Naples yellow 2, wet-smoothed after shaving. See Pl. 99:21 for photograph.	LB II
	P 3174	Jug	Same type as No. 1 except for brown ocher 2 surface	LB II
2	P 3183	Jug	Intact, few minute light grits, brown ocher 2 and naples yellow 2 surface, vertical shaving. See Pl. 99:20 for photograph.	LB II
	P 3387	Jug	Same type as No. 2	LB II
3	P 3198	Jug	Naples yellow 3	LB I
4	P 3179	Jug	Many mixed grits, blue-black 3 core, brown ocher 2 surface, light red 2 decoration. See Pl. 99:22 for photograph.	LB II
5	P 3002	Jar	Many mixed grits, blue-black 3 core, brown ocher 2 surface, spaced horizontal burnishing, indian red 2 decoration. See Pl. 99:14 for photograph.	LB II
	P 3003 } P 3345 }	Jars	Same type as Pl. 18:3	LB II
6	P 3182	Lamp	Intact, brown ocher 2 surface (see pp. 150 and 156). See Pl. 99:24 for photograph.	LB II
	P 3000	Lamp	Same type as No. 6	LB II
7	P 3196	Lamp	Many mixed grits, blue-black 3 core, brown ocher 2. See Pl. 99:23 for photograph.	LB I
	P 3193 } P 3199 } P 3309 }	Lamps	Same type as No. 7 except for blue-black 3 core (see Fig. 40)	LB I
TOMB 989 D 1				
8	P 3390	Jug	Many mixed grits, well fired, brown ocher 2, indian red 2 decoration	LB I
9	P 3397	Cooking bowl	Many light grits, lightly fired, blue-black 3 core, burnt umber 1 surface (see p. 155)	LB II
10	P 3400	Jug	Many mixed grits, blue-black 3 core, brown ocher 2 surface	LB II
TOMB 878 SHAFT				
11	P 3348	Bowl	Some minute mixed grits, vandyke brown 3 core, burnt umber 2 surface, handmade	MB I*
TOMB 878 A				
12	P 3333	Bowl	Fine ware, many mixed grits, brown ocher 3 core, permanent yellow 3 to brown ocher 3 surface, handmade. See Pl. 101:3 for photograph.	MB I
13	P 3552	"Teapot"	Fine ware, many minute light grits, well made, well fired, blue-black 3 core, blue-black 3 to indian red 3 surface, naples yellow 3 decoration	MB I
14	P 3332	"Teapot"	Many minute light grits, well fired, vandyke brown 3 core, roman sepia 3 surface, incised decoration, handmade	MB I
15	P 3328	"Teapot"	Many minute light grits, burnt umber 2 core, burnt umber 2 to naples yellow 2 surface, handmade (see p. 148). See Pl. 101:4 for photograph.	MB I
16	P 3331	Jug	Many mixed grits, permanent brown 2 core, brown ocher 2 inside surface, indian red 2 wash outside and over rim, handmade	MB I
17	P 3350	Jug	Many minute mixed grits, burnt umber 2 core, chiefly brown ocher 2 surface, handmade. See Pl. 101:6 for photograph.	MB I
18	P 3349	Jug	Many minute mixed grits, permanent brown 3 core, naples yellow 2 surface, handmade	MB I
19	P 3335	Jar	Many dark grits, poorly made, naples yellow 2, handmade	MB I
	P 3334	Jar	Burnt umber 2 core, naples yellow 2 surface, handmade	MB I
	P 3553	Milk-bowl handle	Handmade; Cypriote; intrusive	LB
TOMB 880 A				
20	P 3575	Jug	Many mixed grits, well fired, roman sepia 2 core, naples yellow 2 surface, handmade	MB I
TOMB 884 A				
21	P 3421	Jar	Many dark grits, poorly made, naples yellow 2, handmade	MB I
22	P 3415	Jar	Same as No. 21 except that it is fairly well made. See Pl. 101:10 for photograph.	MB I
23	P 3417	"Teapot"	Many minute mixed grits, naples yellow 1, handmade	MB I
24	P 3420	"Teapot"	Many minute mixed grits, permanent brown 3 core, brown ocher 2 inside surface, light red 1 wash outside and over rim, handmade	MB I
25	P 3418	"Teapot"	Same as No. 23. See Pl. 101:12 for photograph.	MB I
26	P 3419	Jug	Same as No. 24 except for naples yellow 2 inside surface	MB I
27	P 3414	Jug	Same as No. 24 except for indian red 2 wash	MB I
28	P 3413	Jug	Same as No. 24	MB I
29	P 3412	Jug	Same as No. 24 except for burnt umber 2 core. See Pl. 101:11 for photograph.	MB I
30	P 3410	Jar	Many minute mixed grits, permanent brown 3 core, naples yellow 2 surface, folded ledge handles, handmade	MB I

\* Described erroneously as Ghassulian in SAOC No. 10, p. 68.

TOMB 989 C I

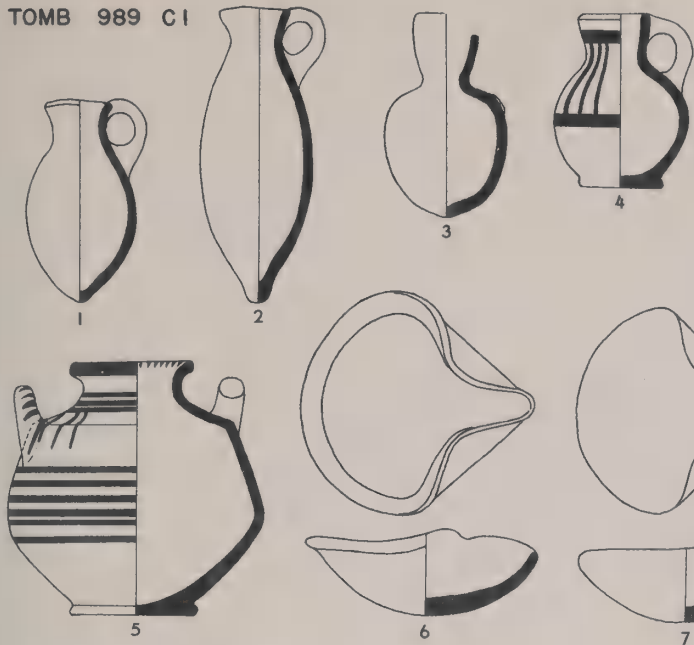

TOMB 989 D I

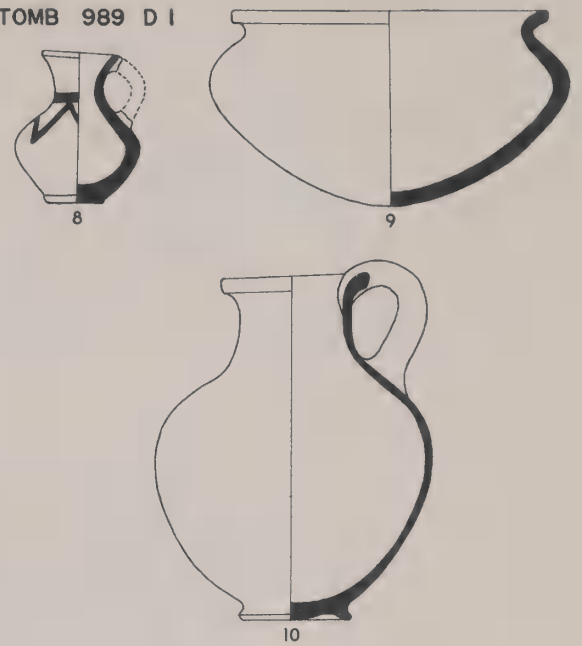

TOMB 878 SHAFT TOMB 878 A

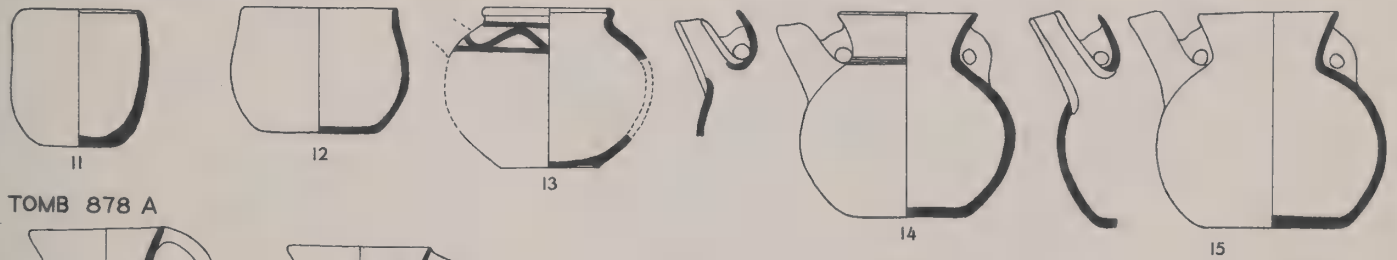

TOMB 878 A

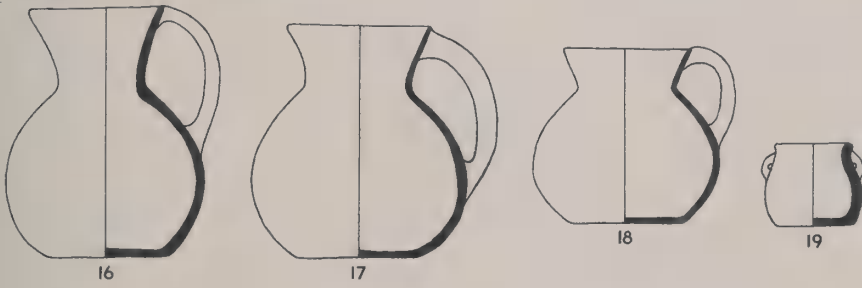

TOMB 880 A

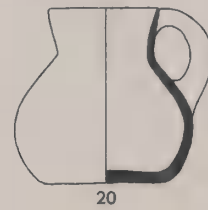

TOMB 884 A



TOMB 884 A

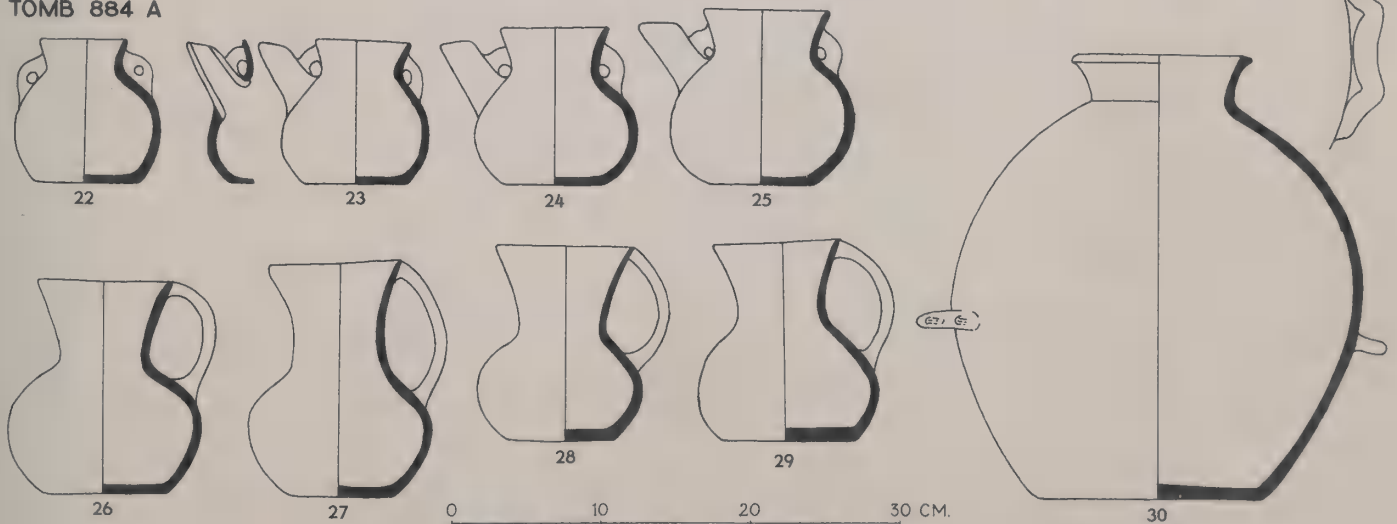

0 10 20 30 CM.

No.	Field No.	Designation	Description	Date
TOMB 884 C				
1	P 3408	Jar	Many dark grits, roman sepia 2 core, warm sepia 3 surface, raised rope decoration, handmade	MB I
TOMB 884 D				
2	P 3409	Cooking bowl	Many mixed grits, blue-black 3 core, burnt umber 1 surface, blackened by fire	LB I
3	P 3408 <i>a</i>	Jug	Many large mixed grits, blue-black 3 core, burnt umber 3 surface	LB I
TOMB 1098 SHAFT				
4	P 4039	"Teapot"	Many minute mixed grits, brown ocher 3, handmade. See Pl. 101:15 for photograph.	MB I
5	P 4044	"Teapot"	Many minute mixed grits, naples yellow 2, light red 2 wash outside and over rim, handmade	MB I
6	P 4038	Jug	Same as No. 5 except for darker wash. See Pl. 101:14 for photograph.	MB I
TOMB 1098 A				
7	P 4040	Jug	Same as No. 4 except for naples yellow 2 core and surface. See Pl. 101:17 for photograph.	MB I
8	P 4042	Jar	Same as No. 4 except for indian red 2 decoration (see p. 148). See Pl. 101:16 for photograph.	MB I
9	P 4037	Jar	Many minute mixed grits, roman sepia 3 core, brown ocher 2 surface, indian red 2 and incised rope decoration, handmade (see pp. 148 f.). See Pl. 101:20 for photograph.	MB I
10	P 4043	Jar	Many minute mixed grits, naples yellow 3 to blue-black 3 core, naples yellow 2 surface, indian red 2 and incised rope decoration, folded ledge handles, handmade (see p. 148). See Pl. 101:19 for photograph.	MB I
11	P 4041	Jar	Many minute mixed grits, permanent yellow 3, handmade; warped. See Pl. 101:18 for photograph.	MB I
TOMB 891 A				
12	P 3601	Jar	Many minute mixed grits, naples yellow 2, handmade. See Pl. 102:2 for photograph.	MB I
13	P 3604	Jar	Many minute mixed grits, brown ocher 2, traces of indian red 2 wash outside and over rim, naples yellow 2 decoration, handmade	MB I
14	P 3600	"Teapot"	Many minute mixed grits, well fired, permanent brown 1 core, lighter surface, handmade	MB I
15	P 3603	"Teapot"	Many minute mixed grits, burnt umber 2, handmade	MB I
16	P 3602	"Teapot"	Many minute mixed grits, well fired, roman sepia 2 core, brown ocher 3 inside surface, light red 1 wash outside and over rim, handmade (see p. 148)	MB I
17	P 3598	Jug	Many minute mixed grits, permanent brown 3 core, naples yellow 2 surface, handmade (see p. 148)	MB I
18	P 3599	Jug	Many minute mixed grits, burnt umber 2 core, naples yellow 1 surface, handmade (see p. 148)	MB I
19	P 3605	Jug	Same as No. 16 except for brown ocher 3 core	MB I
20	P 3614	Jar	Many minute mixed grits, well fired, brown ocher 3 core, near permanent yellow 3 surface, incised decoration, folded ledge handles, handmade. See Pl. 102:1 for photograph.	MB I
21	P 3613	Jar	Same as No. 20 except for no decoration; warped	MB I

TOMB 884 C

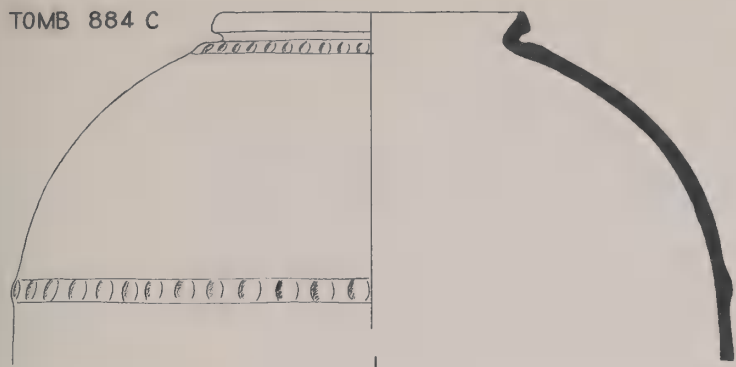

TOMB 884 D

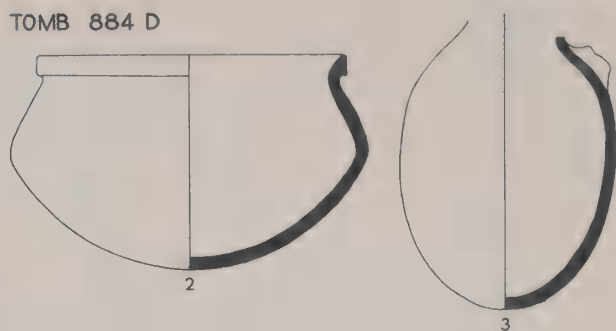

TOMB 1098 SHAFT

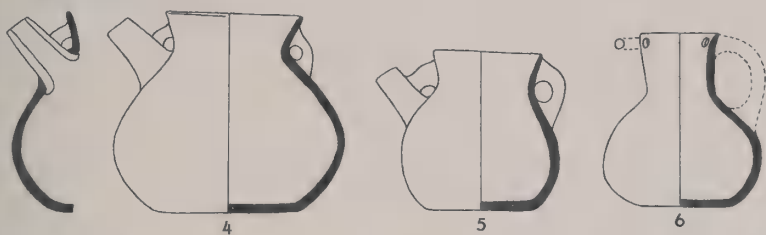

TOMB 1098 A

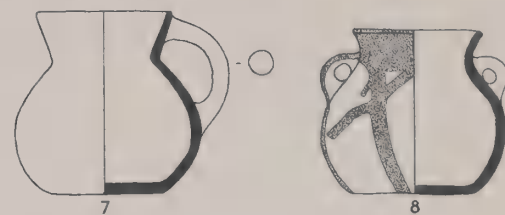

TOMB 1098 A

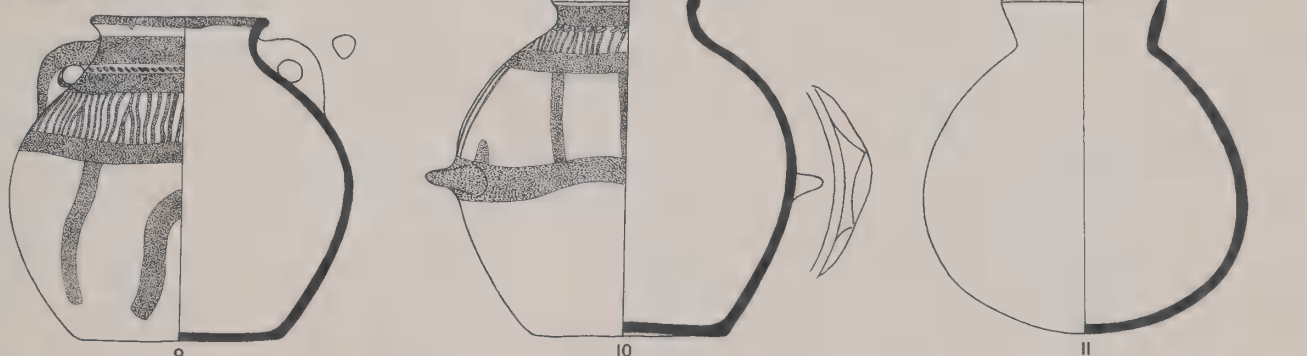

TOMB 891 A

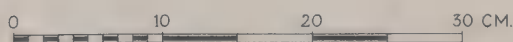
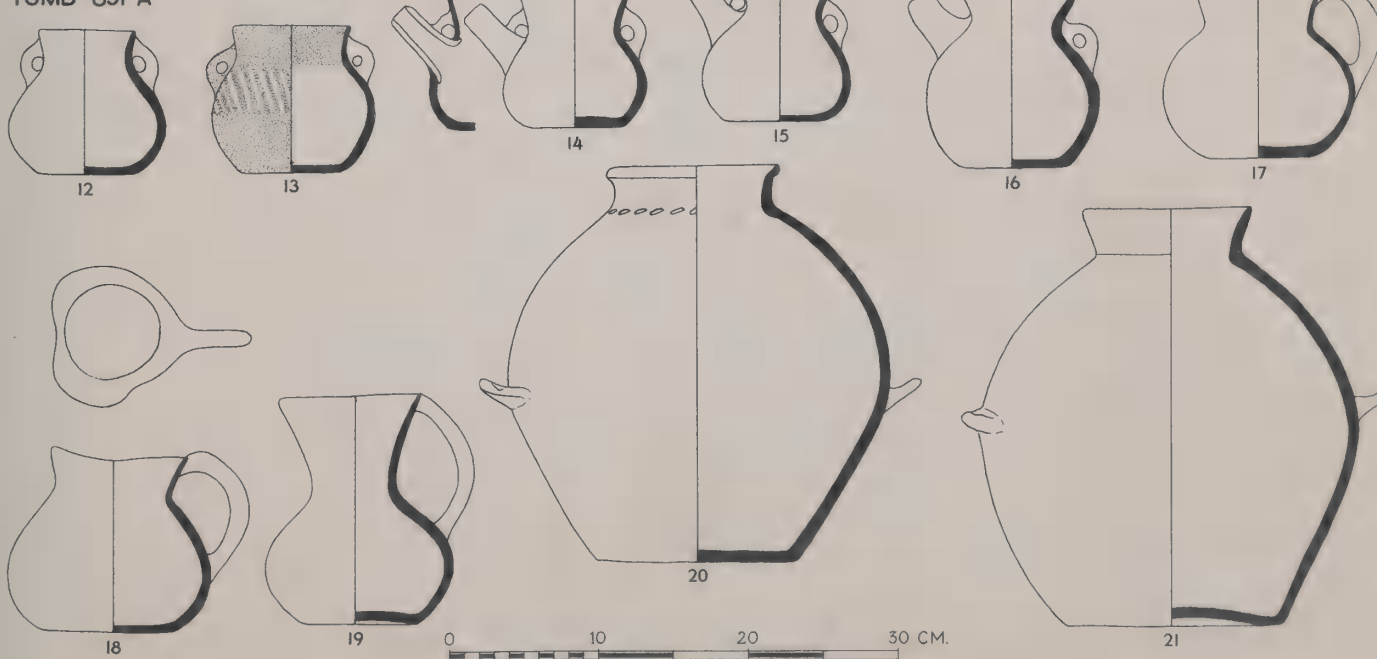

No.	Field No.	Designation	Description
TOMB 922 A			
1	P 3384	Jug	Many minute mixed grits, roman sepia 2 core, naples yellow 2 surface, indian red 2 wash outside and over rim, handmade. See Pl. 102:3 for photograph.
2	P 3385	Jar	Many minute mixed grits, brown ocher 3, handmade
TOMB 1014 A			
3	P 3608	"Teapot"	Many light grits, well made, well fired, blue-black 3 core, indian red 3 to blue-black 3 surface, naples yellow 3 decoration (see p. 148). See Pl. 102:4 for photograph.
4	P 3609	"Teapot"	Same as No. 3
5	P 3610	"Teapot"	Many light grits, well made, well fired, indian red 3 core and inside surface, blue-black 3 outside surface, naples yellow 3 decoration
6	P 3606	Jug	Many minute mixed grits, permanent brown 3 core, naples yellow 2 surface, handmade. See Pl. 102:6 for photograph.
7	P 3607	Jug	Some minute mixed grits, well made, blue-black 3 core, naples yellow 2 and brown ocher 2 inside surface, light red 1 wash outside and over rim, handmade. See Pl. 102:5 for photograph.
TOMB 1014 B			
8	P 3611	Bowl	Many minute mixed grits, brown ocher 1 (see p. 149)
9	P 3612	Jug	Many large predominantly light grits, brown ocher 2 to blue-black 3, traces of light red 2 wash and vertical burnishing, pinched lip
TOMB 1120 A			
10	P 3975	Bowl	Many minute dark grits, naples yellow 2, handmade. See Pl. 102:11 for photograph.
11	P 3976	Bowl	Many minute dark grits, blue-black 3 core, naples yellow 2 surface, handmade. See Pl. 102:12 for photograph.
12	P 3977	Bowl	Same as No. 11
13	P 3978	Jar	Many minute dark grits, poorly made, naples yellow 2, handmade
14	P 3967	Jar	Intact, many minute mixed grits, brown ocher 3 and blue-black 3 surface, handmade (see p. 148). See Pl. 102:13 for photograph.
15	P 3979	Jar	Many minute dark grits, naples yellow 2, handmade
16	P 3974	Jar	Same as No. 15
17	P 3980	Jug	Many minute light grits, brown ocher 3, indian red 2 wash outside and over rim, handmade
	P 3966	Jug	Same shape as No. 17, many minute mixed grits, naples yellow 2, light red 1 wash outside and over rim, handmade; MB I
TOMB 1120 B			
18	P 3970	Jar	Many minute mixed grits, naples yellow 2, impressed decoration, folded ledge handles, handmade. See Pl. 102:14 for photograph.
19	P 3968	Cup	Fine ware, many light grits, well made, well fired, indian red 3 core and inside surface, blue-black 3 outside surface, naples yellow 3 decoration; zigzag made by scraping off yellow paint while wet (see pp. 47 and 148). See Pl. 102:15 for photograph.
20	P 3969	Jar	Same as No. 18 except for no decoration
TOMB 1120 C			
21	P 3981	Jug	Many minute mixed grits, permanent brown 3 core, brown ocher 2 surface, traces of indian red 2 wash, handmade
TOMB 1120 D			
22	P 3971	Bowl	Many minute dark grits, poorly made, naples yellow 2, suspension(?) hole (perhaps 2 holes) near rim, handmade
TOMB 1120 E			
23	P 3972	Jug	Intact, many minute dark grits, naples yellow 2 surface, handmade. See Pl. 102:16 for photograph.
24	P 3973	Jug	Many minute dark grits, naples yellow 2, handmade. See Pl. 102:17 for photograph.

TOMB 922 A

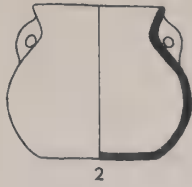

TOMB 1014 A

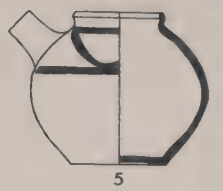
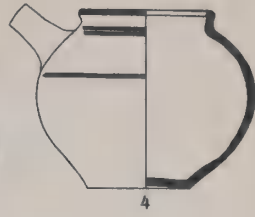
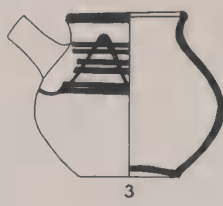

TOMB 1014 A

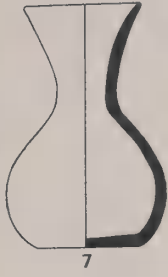
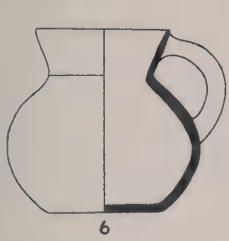

TOMB 1014 B

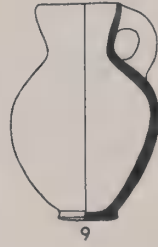
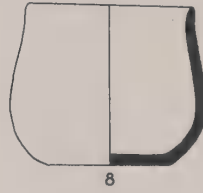

TOMB 1120 A

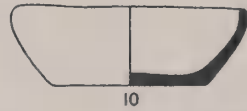

TOMB 1120 A

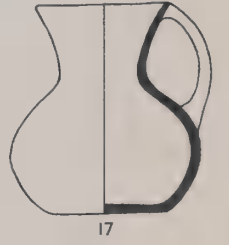
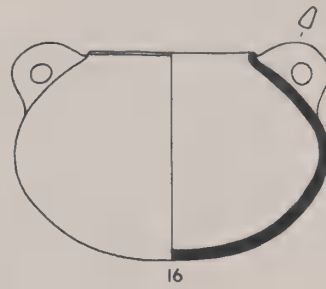
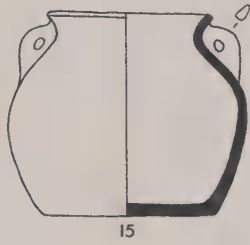
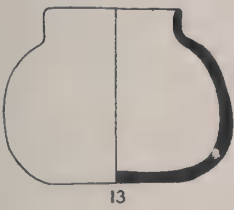

TOMB 1120 B

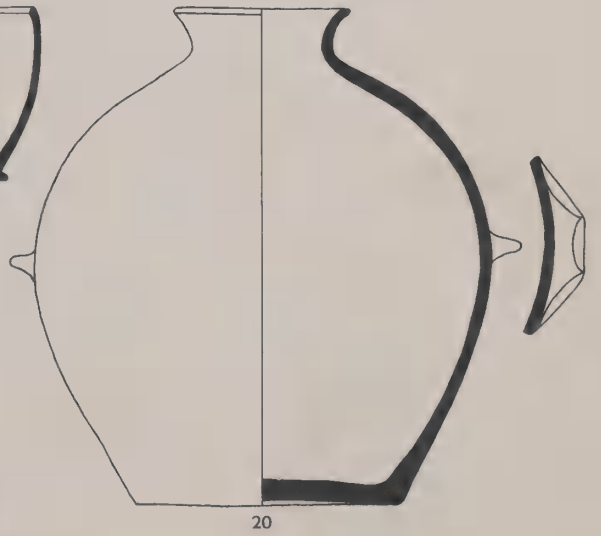
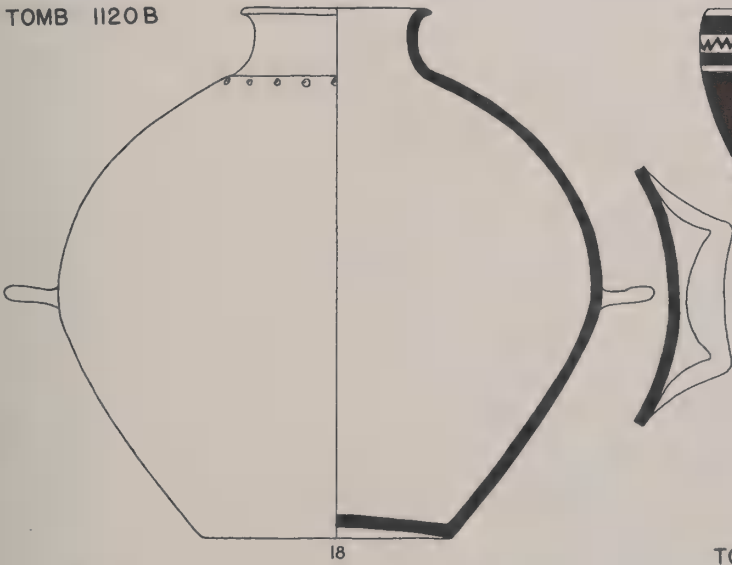

TOMB 1120 C

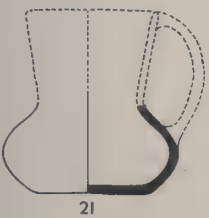

TOMB 1120 D



TOMB 1120 E

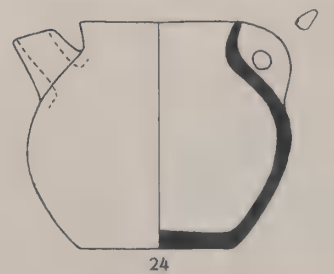

No.	Field No.	Designation	Description
1	7067	Bowl	Burnt umber 3 core, permanent yellow 3 surface
2	x 02831	Bowl	Well made, permanent brown 3 (see p. 150). See Pl. 103:1 for photograph.
3	7069	Bowl	Same as No. 2
4	02828	Bowl	Same as No. 2
5	x 2894	Bowl	Well made, brown ocher 3
6	x 2892	Bowl	Few mixed grits, well made, brown ocher 3, indian red 3 slip
	7070 } x 2907 } x 2912 }	Bowls	Same type as No. 6; MB II
7	x 2910	Bowl	Well made, brown ocher 3, hand burnishing inside toward center
	7071 } 02827 }	Bowls	Same type as No. 7; MB II
8	x 2900	Bowl	Well made, brown ocher 3, burnished (see p. 150)
	x 02903	Bowl	Same type as No. 8; MB II
9	x 2915	Bowl	Well made, charcoal gray 1 core, brown ocher 3 surface (see p. 150)
	x 93 } x 2909 }	Bowls	Same type as No. 9; MB II
10	x 2888	Bowl	Well made, charcoal gray 3 core, brown ocher 3 surface (see p. 150)
	2832 } 7083 } x 2889-90 } x 2893 } x 2895-97 } x 2899 } x 2901-6 } x 2908 } x 2914 } x 7085-86 }	Bowls	Same type as No. 10; MB II
11	7072	Bowl	Well made, charcoal gray 3 core, permanent brown 3 surface. See Pl. 103:5 for photograph.
	7073-79	Bowls	Same type as No. 11; MB II
12	x 2898	Bowl	Well made, brown ocher 3 (see p. 150)
13	x 2876	Bowl	Brown ocher 3
14	x 2877	Lamp	Brown ocher 3 (see p. 150)
15	x 2891	Jug	Many mixed grits, well made, permanent brown 3, indian red 3 wash, spaced vertical burnishing, triple handle (see p. 150). See Pl. 103:11 for photograph.
16	x 2869	Jug	Well made, brown ocher 3 core, indian red 3 surface
17	x 2870	Jug	Brown ocher 3 core, indian red 3 surface. See Pl. 103:12 for photograph.
	7081-82 } x 2871 } x 2873-74 } x 02872 }	Jugs	Same type as No. 17; MB II
18	02829	Jug	Well made, permanent brown 3 core, permanent brown 3 and burnt umber 3 surface, irregular hand burnishing. See Pl. 103:9 for photograph.
19	x 2864	Jug	Brown ocher 3, indian red 3 slip (see p. 150). See Pl. 103:16 for photograph.
20	x 2913	Jug	Brown ocher 3. See Pl. 103:7 for photograph.
21	x 2875	Jug	Brown ocher 3
22	x 2917	Jug	Permanent brown 2 core, burnt umber 3 surface. See Pl. 103:17 for photograph.
23	x 2920	Jug	Few mixed grits, well made, charcoal gray 3, incised decoration filled with white (lime?), pottery mark on base, triple handle (see p. 150)
24	x 2867	Jug	Permanent brown 3, polished
25	x 2868	Jug	Brown ocher 3, indian red 3 slip, burnished
	7089 } x 2878 } x 2883-87 }	Jugs	Same type as No. 25; MB II
26	x 94	Jug	Well made, permanent yellow 1, double handle (see p. 150)
27	x 2918	Jug	Few mixed grits, well made, permanent brown 3 core, charcoal gray 1 surface, incised decoration filled with white (lime?). See Pl. 103:14 for photograph.
28	x 2865	Jug	Brown ocher 3, indian red 3 slip, burnished, double handle (see p. 150)
	7088 } x 2866 } x 2879-82 }	Jugs	Same type as No. 28; MB II
29	7087	Jug	Few mixed grits, well made, permanent brown 3, burnt umber 3 decoration (see p. 151)
30	x 2919	Jug	Few mixed grits, well made, charcoal gray 3, incised decoration filled with white (lime?). See Pl. 103:15 for photograph.
	x 2916	Jug	Same type as Pl. 25:3; MB II
		Sherds	LB II

TOMB 24

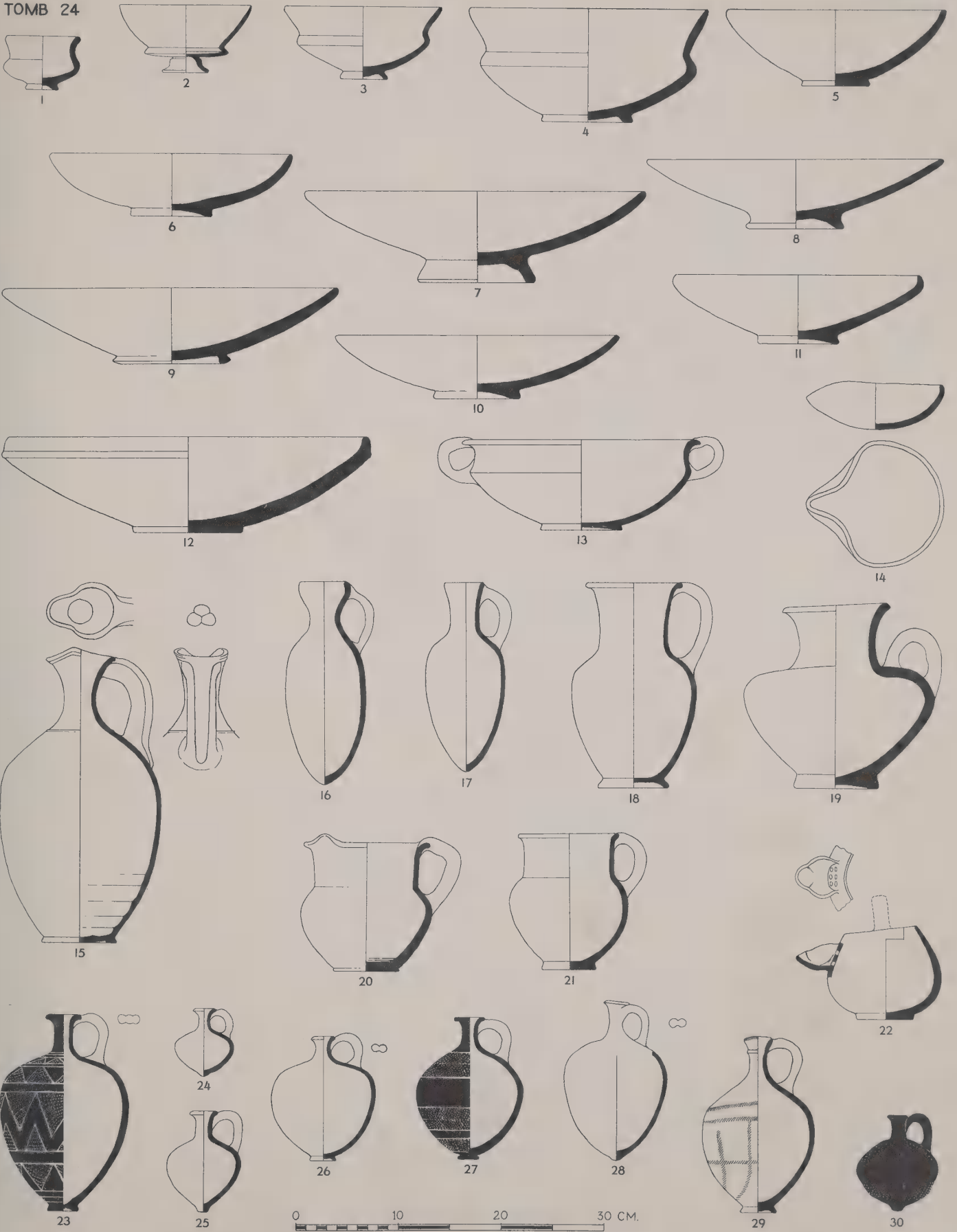

MB II POTTERY FROM TOMB 24 (SEE PP. 48-50). SCALE, 1:5

No.	Field No.	Designation	Description
TOMB 42			
1	x 884	Bowl	Brown ocher 3; warped
	x 31 x 883 x 885 x 884	Bowls	Same type as No. 1; MB II
2	x 886	Bowl	Permanent yellow 3. See Pl. 107:4 for photograph.
3	x 865	Jug	Permanent yellow 3, shaved, roman sepia 2 decoration, spout and handle thrust through, handmade; Cypriote (see p. 151). See Pl. 107:8 for photograph.
4	x 0949	Jug	Brown ocher 3
5	x 887	Jug	Permanent brown 3 core, indian red 3 surface (see p. 150). See Pl. 107:7 for photograph.
	x 32	Jug	Same type as No. 5; MB II
6	949	Jar	Brown ocher 3
	x 866	Jar	Same type as Pl. 23:25; MB II
	x 7	Lamp	Same type as Pl. 23:14; MB II
		Sherds	LB II
TOMB 43			
7	x 5	Jar	Brown ocher 3
8	x 0954	Bowl	Permanent brown 3 (see p. 150)
9	x 7	Bowl	Permanent brown 3 core, naples yellow 3 surface
	x 3	Bowl	Same type as No. 1; MB II
	x 12	Handle	Same type as that of Pl. 23:15; MB II
TOMB 44			
10	x 14	Jug	Brown ocher 3. See Pl. 110:8 for photograph.
11	x 2947	Jug	Brown ocher 3. See Pl. 110:12 for photograph.
12	x 8	Jug	Poorly made, brown ocher 3
13	x 889	Bowl	Brown ocher 3 (see p. 150). See Pl. 110:5 for photograph.
14	x 890	Bowl	Brown ocher 3. See Pl. 110:4 for photograph.
15	x 2948	Jug	Brown ocher 3. See Pl. 110:11 for photograph.
16	x 888	Jug	Brown ocher 3, indian red 3 slip, horizontal burnishing. See Pl. 110:13 for photograph.
17	x 10	Jug	Brown ocher 3. See Pl. 110:10 for photograph.
18	x 6	Jug	Brown ocher 3 (see p. 150). See Pl. 110:14 for photograph.

TOMB 42

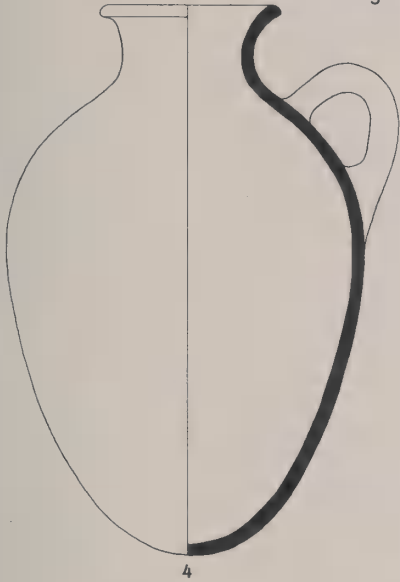
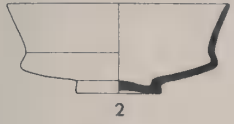
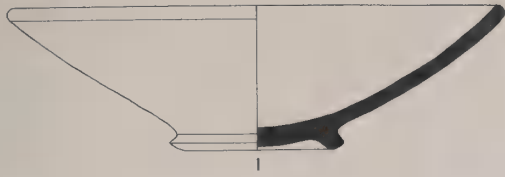

TOMB 44

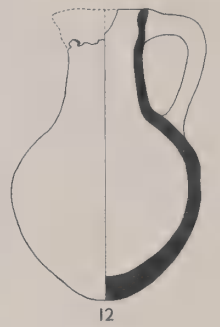
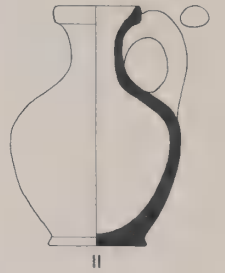

TOMB 43

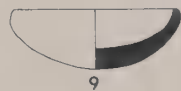
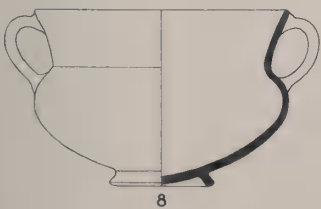
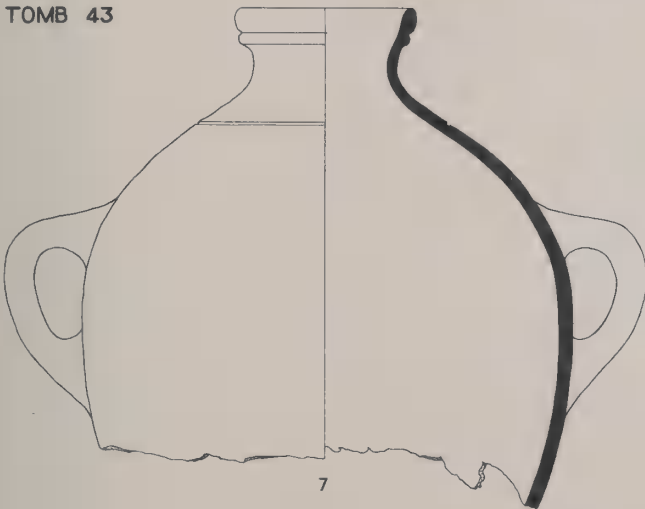

TOMB 44

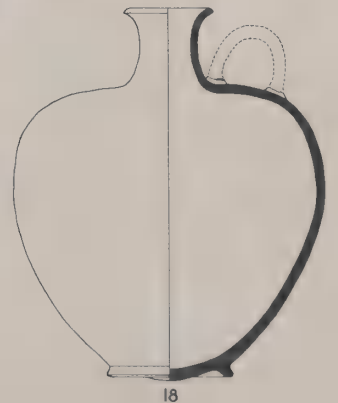
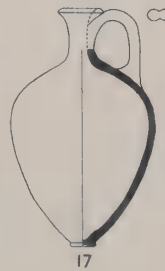
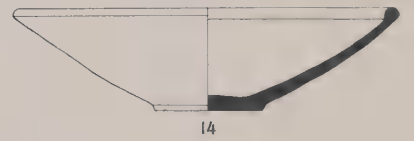
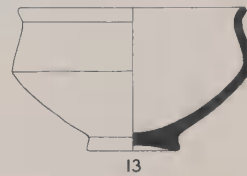

MB II POTTERY FROM TOMBS 42-44 (SEE PP. 51 F.). SCALE, 1:5

No.	Field No.	Designation	Description
TOMB 45			
1	x 0935	Jug	Permanent brown 3, indian red 3 slip, double handle
	x 0936	Jug	Same type as No. 1; MB II
2	0936 <i>a</i>	Jug	Permanent brown 3
	x 0936 <i>b</i>	Jug	Same type as No. 2; MB II
3	x 18	Jug	Permanent brown 3
4	7091	Jug	Brown ocher 3 (see p. 150)
	x 19	Jug	Same type as No. 4; MB II
	x 17	Lamp	Same type as Pl. 23:14; MB II
TOMB 49			
5	x 2950	Jug	Permanent brown 3 (see p. 150)
6	x 02962	Jug	Burnt umber 3, indian red 2 slip; may have had a handle
7	x 02958	Bowl	Burnt umber 3. See Pl. 112:4 for photograph.
8	x 2952	Bowl	Permanent brown 3 core, brown ocher 3 surface
9	x 2953	Jug	Brown ocher 3. See Pl. 112:8 for photograph.
	01969	Jug	Same type as No. 9; MB II
10	x 2958	Jug	Brown ocher 3, indian red 3 slip
11	x 2960	Jug	Brown ocher 3, naples yellow 2 slip, double handle (see p. 150)
	x 16-17	Jugs	Same type as No. 11; MB II
12	x 2954	Jug	Naples yellow 2, double handle
	x 9	Jugs	Same type as No. 12; MB II
	x 18		
	x 2955		
	x 19	Jug	Same type as No. 2; MB II
	x 02961	Lamp	Same type as Pl. 23:14; MB II
TOMB 233			
13	P 194	Bowl	Many large mixed grits, naples yellow 2 core, burnt umber 3 surface, spaced irregular burnishing, indian red 2 decoration (see p. 150)
14	4392	Jug	Many mixed grits, well fired, brown ocher 2. Cf. Pl. 114:14 for shape.
15	P 188	Jug	Permanent brown 3 core, burnt umber 3 surface (see pp. 150 f.). See Pl. 114:9 for photograph.
16	P 186	Jug	Many mixed grits, well fired, burnt umber 3, traces of light red 3 wash and vertical burnishing (see pp. 150 f.). See Pl. 114:10 for photograph.
17	P 187	Jug	Some minute mixed grits, brown ocher 2 core, chiefly naples yellow 2 surface, close vertical burnishing (see pp. 150 f.). See Pl. 114:11 for photograph.
18	P 220	Lamp	Well fired, permanent brown 3 core, burnt umber 3 surface
19	P 185	Jug	Many mixed grits, well fired, burnt umber 3 core, permanent yellow 3 surface, incised decoration (see p. 150). See Pl. 114:12 for photograph.

TOMB 45

TOMB 49

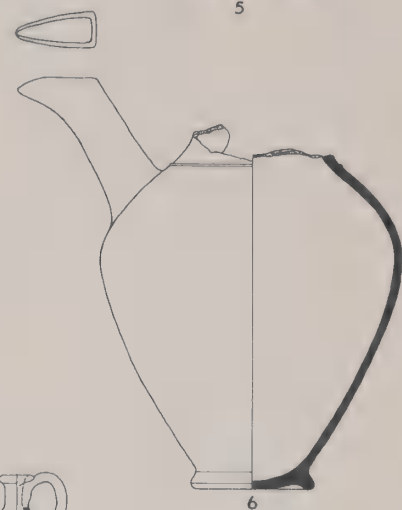
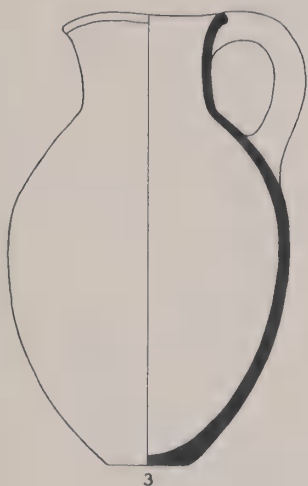
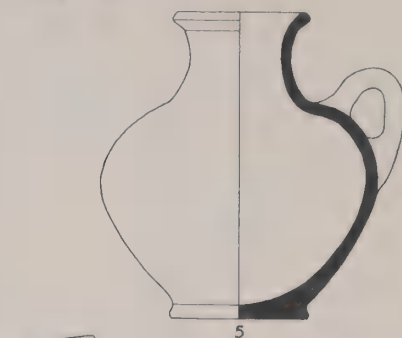
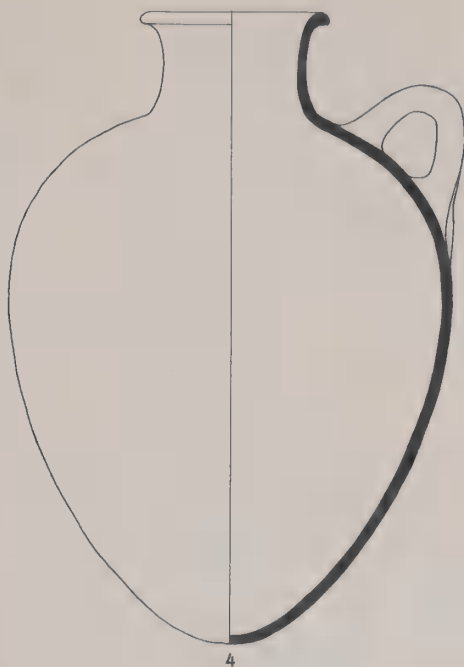
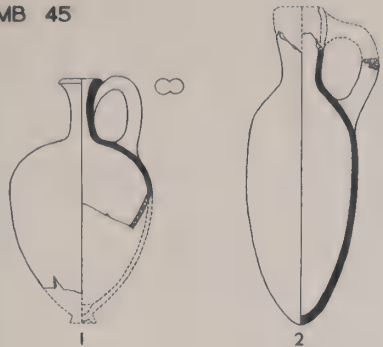

TOMB 49

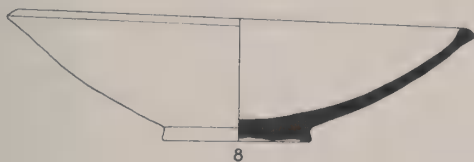
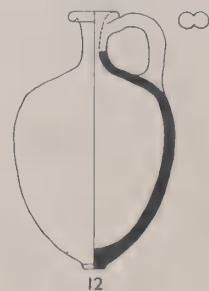
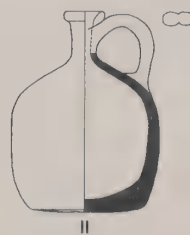
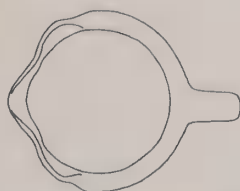

TOMB 233

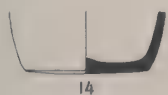
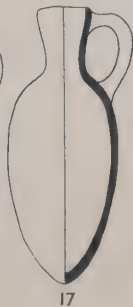
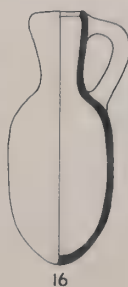
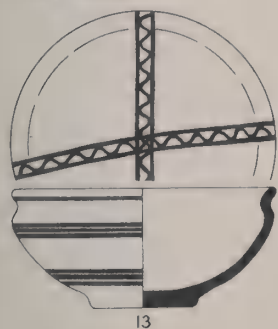

MB II POTTERY FROM TOMBS 45, 49, AND 233 (SEE PP. 52 AND 54 F.). SCALE, 1:5

No.	Field No.	Designation	Description
TOMB 233			
1	P 184	Jug	Roman sepia 3 core, burnt umber 3 and brown ocher 3 surface
2	P 183	Jug	Many minute mixed grits, well fired, blue-black 3 to naples yellow 3 core, burnt umber 2 surface
TOMB 247			
3	4630	Jug	Well made, well fired, naples yellow 3, double handle; found with No. 4 in large jar containing child burial (see Fig. 60)
4	4629	Jug	Burnt umber 3 core, burnt umber 3 to permanent brown 3 surface; found with No. 3
TOMB 234			
5	P 365	Bowl	Many mixed grits, brown ocher 3. See Pl. 114:13 for photograph.
6	P 366	Jug	Some minute mixed grits, well made, naples yellow 2, close vertical burnishing, double handle. See Pl. 114:14 for photograph.
7	P 367	Jug	Many minute mixed grits, well made, well fired, permanent yellow 3, spaced vertical burnishing. See Pl. 114:15 for photograph.
8	P 369	Jug	Many mixed grits, well fired, brown ocher 3 core, brown ocher 2 to 3 surface, spaced vertical burnishing
9	P 368	Jug	Same as No. 8 except for permanent brown 3 core and no burnishing (see p. 150)
TOMB 251			
10	P 407	Bowl	Blue-black 3 core, burnt umber 2 surface. See Pl. 115:1 for photograph.
11	P 390	Bowl	Fine ware, some minute mixed grits, well made, brown ocher 2, close horizontal burnishing outside and over rim (see p. 150). See Pl. 115:2 for photograph.
12	P 389	Bowl	Fine ware, few minute light grits, well made, well fired, davy's gray 3, naples yellow 3 slip, close ring burnishing (see p. 150). See Pl. 115:3 for photograph.
13	P 409	Jug	Fine ware, some light grits, well made, well fired, naples yellow 3, close vertical burnishing. See Pl. 115:4 for photograph.
14	P 410	Jug	Fine ware, many minute light grits, well fired, blue-black 3 core, naples yellow 3 to burnt umber 3 surface. See Pl. 115:5 for photograph.
15	P 408	Jug	Intact, few mixed grits, well fired, naples yellow 2 surface. See Pl. 115:6 for photograph.
16	P 411	Jug	Many minute mixed grits, brown ocher 2
17	P 391	Jug	Fine ware, few light grits, well made, black lead 3 core, roman sepia 1 surface, close vertical burnishing. See Pl. 115:7 for photograph.
18	P 406	Jug	Fine ware, few minute mixed grits, well made, black lead 3 core, black lead 3 to vandyke brown 3 surface, spaced vertical burnishing. See Pl. 115:8 for photograph.
19	P 405	Jug	Brown ocher 3. See Pl. 115:9 for photograph.

TOMB 233

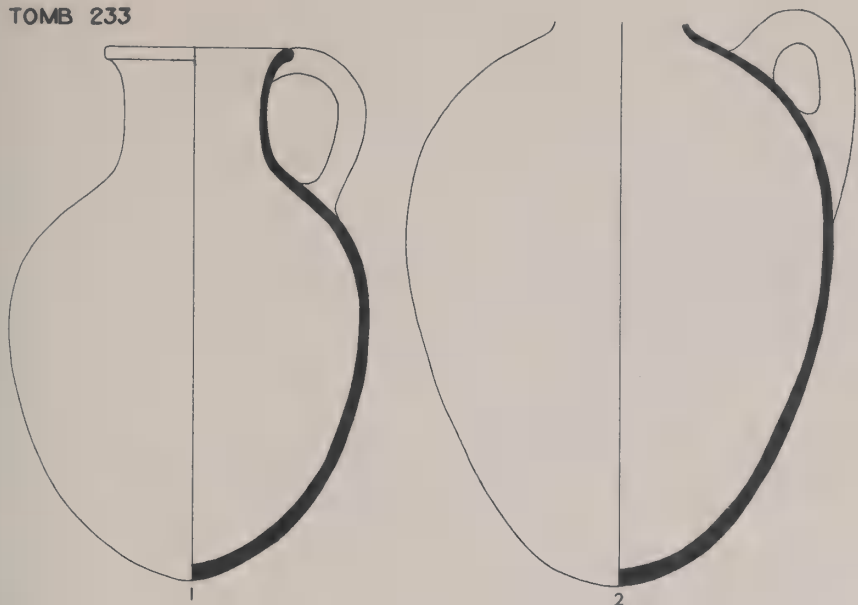

TOMB 247

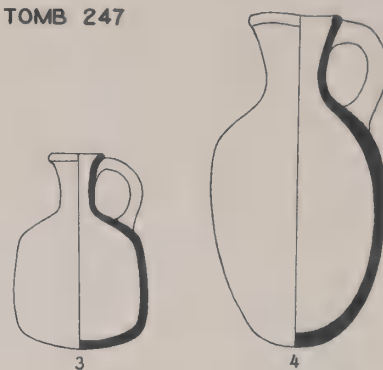

TOMB 234

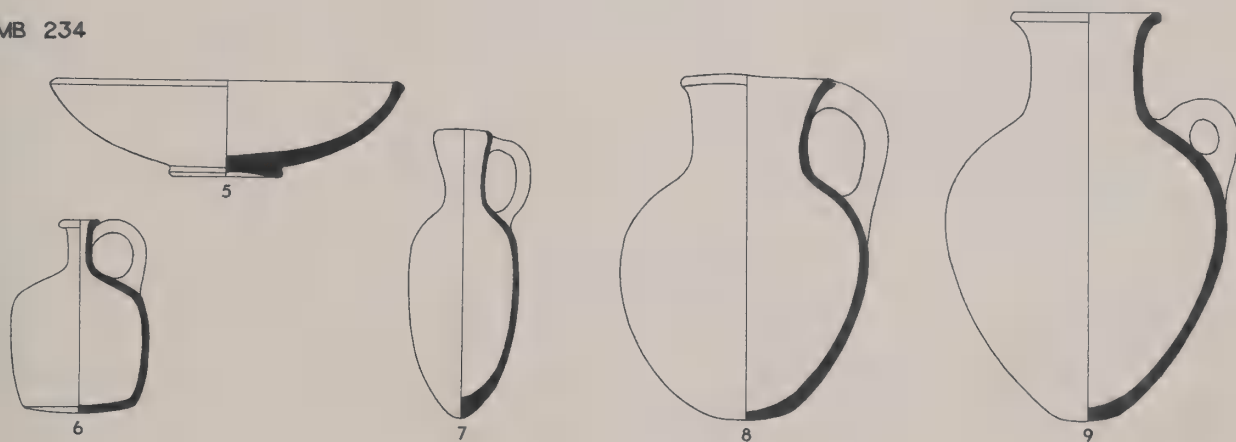

TOMB 251

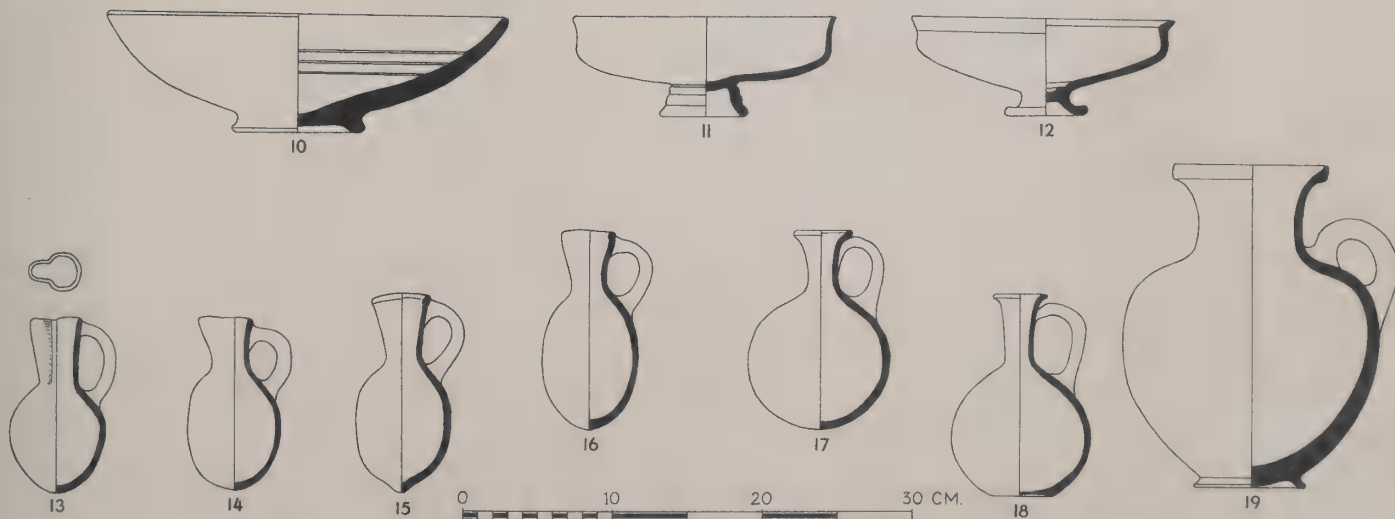

MB II POTTERY FROM TOMBS 233-34, 247, AND 251 (SEE PP. 55-59). SCALE, 1:5

No.	Field No.	Designation	Description
TOMB 253			
1	P 393	Jug	Naples yellow 2, double handle (see p. 150). See Pl. 115:16 for photograph.
2	P 392	Jug	Many mixed grits, brown ocher 3, double handle (see p. 150)
3	P 394	Jug	Fine ware, many minute mixed grits, well made, permanent brown 3 core, chiefly brown ocher 3 surface, traces of light red 3 wash, close vertical burnishing. See Pl. 115:17 for photograph.
4	4345	Jar	Some light grits, brown ocher 2, pottery mark
TOMB 254			
5	P 404	Jar	Many large light grits, brown ocher 3. See Pl. 115:18 for photograph.
		Jar	Same type as No. 5; MB II
TOMB 257			
6	P 399	Cooking bowl	Many mixed grits, burnt umber 1 (see Fig. 66)
TOMB 258			
7	P 400	Jug	Many light grits, chiefly sepia 3 core, brown ocher 3 surface, imprint of cloth binding on shoulder. See Pl. 115:21 for photograph.
8	P 401	Jug	Well made, well fired, brown ocher 2, spaced irregular burnishing. See Pl. 115:22 for photograph.
9	P 402	Jug	Fine ware, few minute mixed grits, well fired, vandyke brown 3 core, roman sepia 3 to black lead 3 surface, close vertical burnishing. See Pl. 115:23 for photograph.
TOMB 644			
10	P 2399	Jug	Many mixed grits, well made, brown ocher 2. See Pl. 116:7 for photograph.
11	P 2400	Jug	Same as No. 10
12	P 2394	Jug	Some dark grits, well fired, permanent brown 1 core, brown ocher 3 surface. See Pl. 116:6 for photograph.
13	P 2401	Jug	Some minute mixed grits, burnt umber 2, traces of light red 2 wash and burnishing; perhaps part of No. 14
14	P 2402	Jug	Same as No. 13, of which it is probably a part
15	P 2395	Bowl	Same as No. 10 except for many light grits. See Pl. 116:5 for photograph.
16	P 2390	Bowl	Few mixed grits, brown ocher 3
17	P 2389	Bowl	Same as No. 10 except for many light grits. See Pl. 116:4 for photograph.
TOMB 645			
18	P 2478	Jug	Intact, poorly made, well fired, naples yellow 2 surface (see p. 150); found with No. 19 in jar containing child burial (see Fig. 68). See Pl. 116:10 for photograph.
19	P 2479	Jug	Intact, many mixed grits, well made, naples yellow 2 surface, double handle; found with No. 18. See Pl. 116:9 for photograph.
TOMB 868			
20	P 2866	Jug	Fine ware, few minute light grits, well made, well fired, blue-black 3 core, darker surface, close vertical burnishing on body, close irregular burnishing on base
21	P 2854	Jug	Well fired, burnt umber 1 core, lighter surface
22	P 2855	Jug	Well fired, permanent brown 2 core, brown ocher 2 surface

TOMB 253

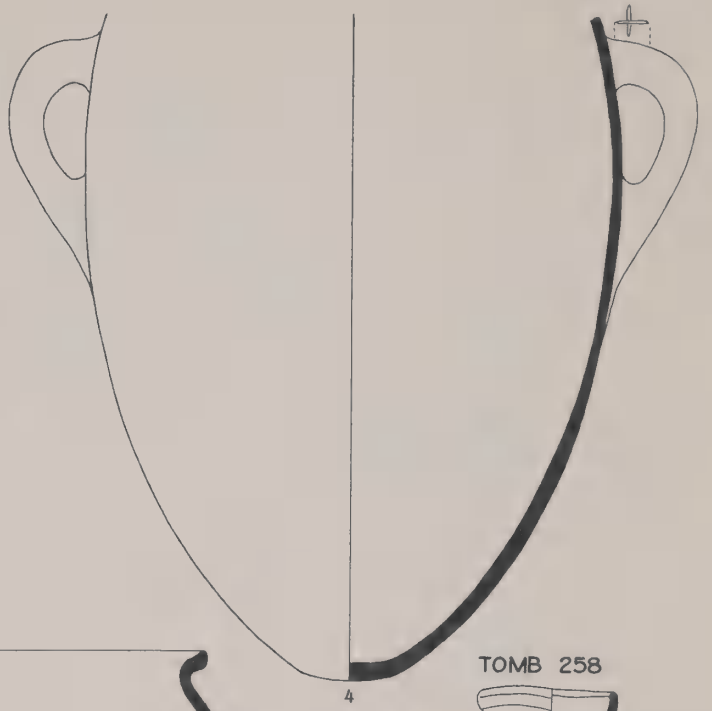
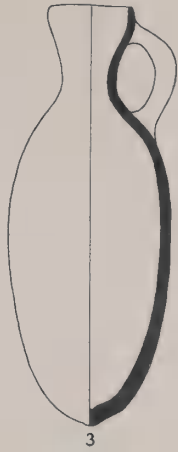
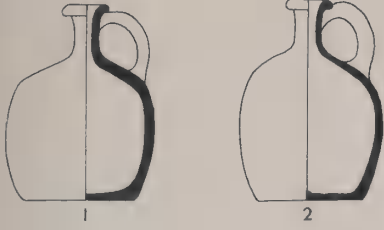

TOMB 254

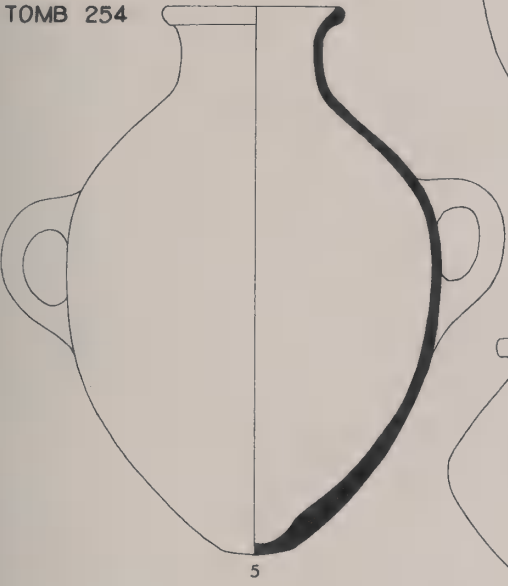

TOMB 257

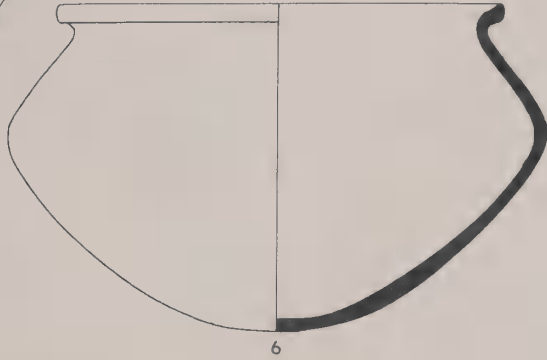

TOMB 258

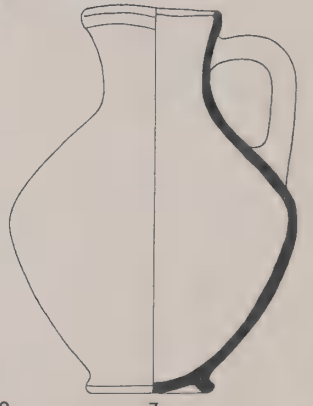

TOMB 644

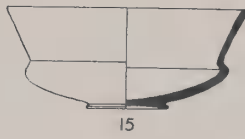
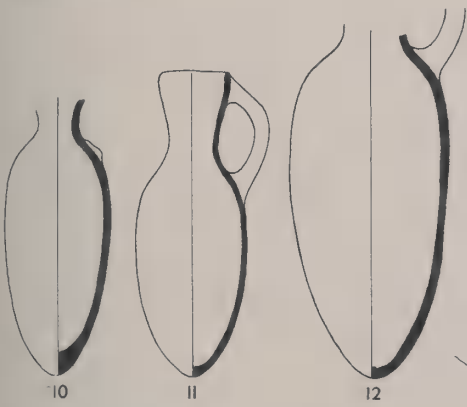

TOMB 258

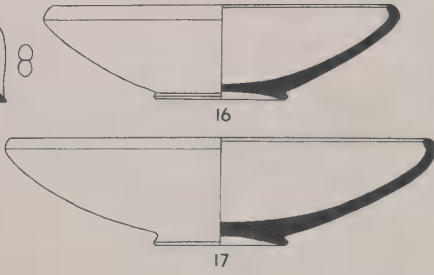
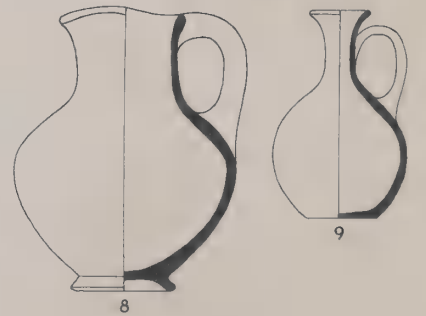

TOMB 645

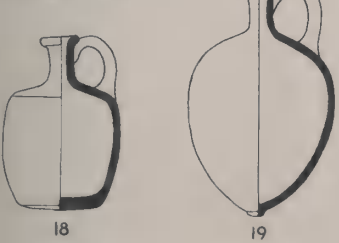

TOMB 868

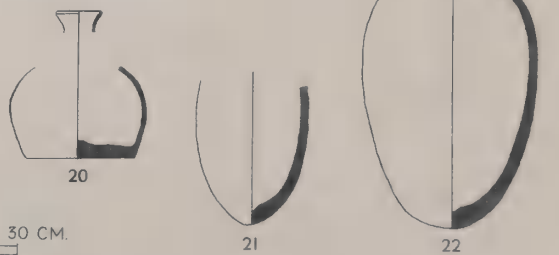

MB II (EXCEPT PERHAPS No. 6) POTTERY FROM TOMBS 253-54, 257-58, 644-45, AND 868 (SEE PP. 59-61). SCALE, 1:5

No.	Field No.	Designation	Description
1	P 3078	Bowl	Intact; same as No. 2. See Pl. 116:17 for photograph.
2	P 3098	Bowl	Many mixed grits, permanent brown 2 core, light red 2 wash over rim (see p. 150)
3	P 3254	Bowl	Same as No. 2
4	P 3096	Bowl	Same as No. 2
5	P 3054	Bowl	Same as No. 2
6	P 3090	Bowl	Same as No. 2 except for blue-black 3 core. See Pl. 116:20 for photograph.
7	P 3074	Bowl	Same as No. 2 except for no wash
8	P 3087	Bowl	Complete; same as No. 2. See Pl. 116:19 for photograph.
9	P 3260	Bowl	Same as No. 2
10	P 3143	Bowl	Same as No. 2 except for brown ocher 2 to Naples yellow 2 surface
11	P 3089	Bowl	Same as No. 2
12	P 3148	Bowl	Same as No. 2 except for Roman sepia 3 core
13	P 3103	Bowl	Same as No. 2. See Pl. 116:22 for photograph.
14	P 3086	Bowl	Same as No. 2
15	P 3085	Bowl	Same as No. 2
16	P 3145	Bowl	Same as No. 2 except for blue-black 3 core. See Pl. 116:18 for photograph.
17	P 3100	Bowl	Same as No. 2. See Pl. 116:21 for photograph.
18	P 3055	Bowl	Same as No. 2
19	P 3088	Bowl	Intact; same as No. 2
20	P 3091	Bowl	Same as No. 2
21	P 3113	Bowl	Same as No. 2 except for lighter surface and no wash
22	P 3097	Bowl	Same as No. 2 except for knobs around rim and no wash. See Pl. 116:23 for photograph.
23	P 3212	Bowl	Many mixed grits, permanent brown 3 core, brown ocher 3 surface, traces of light red 2 wash
24	P 3111	Bowl	Intact, many mixed grits, brown ocher 2 inside surface, light red 1 wash outside and over rim, spaced vertical burnishing
25	P 3064	Bowl	Many mixed grits, brown ocher 2, spaced horizontal burnishing. See Pl. 116:24 for photograph.
26	P 3141	Bowl	Same as No. 25 except for no burnishing
27	P 3261	Bowl	Same as No. 25 except for no burnishing
28	P 3062	Bowl	Same as No. 25 except for light red 2 wash over rim and traces of horizontal burnishing. See Pl. 116:25 for photograph.
29	P 3102	Bowl	Same as No. 25 except for light red 2 wash and no burnishing
30	P 3211	Bowl	Same as No. 25 except for light red 2 wash and no burnishing
31	P 3093	Bowl	Same as No. 25 except for light red 2 wash over rim. See Pl. 116:26 for photograph.
32	P 3239	Bowl	Same as No. 25 except for Indian red 3 wash outside and over rim
33	P 3146	Bowl	Few minute mixed grits, well made, Naples yellow 2, light red 1 wash outside and over rim, close horizontal burnishing on upper outside, close vertical burnishing on lower outside. See Pl. 116:27 for photograph.
34	P 3144	Bowl	Many mixed grits, well made, brown ocher 2, Indian red 3 wash outside and over rim, spaced horizontal burnishing
35	P 3147	Bowl	Many mixed grits, permanent brown 3 core, brown ocher 2 surface, light red 2 wash over rim. See Pl. 116:28 for photograph.
36	P 3230	Bowl	Same as No. 34 except for spaced horizontal burnishing on upper outside and spaced vertical burnishing on lower outside
37	P 3082	Bowl	Same as No. 35 except for brown ocher 2 core and surface
	P 3094	Bowl	Same type as No. 37; MB II
38	P 3241	Bowl	Same as No. 35 except for smaller grits and brown ocher 2 core and surface
39	P 3251	Jug	Some minute mixed grits, permanent brown 3 core, Naples yellow 3 inside surface, light red 1 wash outside, spaced vertical burnishing
40	P 3107	Jug	Many minute mixed grits, near Roman sepia 2, traces of brown 1 wash and close vertical burnishing, punctate and incised decoration filled with chalk(?)
41	P 3240	Jug	Intact, Naples yellow 2 surface, Indian red 3 wash, spaced vertical burnishing. See Pl. 116:29 for photograph.
42	P 3210	Jug	Some minute mixed grits, burnt umber 3, light red 1 wash outside and over rim
43	P 3215	Jug	Fine ware, some minute mixed grits, burnt umber 3, light red 1 wash, spaced vertical burnishing
44	P 3061	Jug	Intact, many mixed grits, well made, brown ocher 2 surface, chiefly spaced vertical burnishing, Indian red 3 decoration too indistinct for complete illustration, triple handle (see p. 150). See Pl. 117:2 for photograph.
45	P 3083	Jug	Many mixed grits, well made, permanent brown 3 core, brown ocher 2 surface, Indian red 3 wash outside and over rim, spaced vertical burnishing, quadruple handle (see p. 150). See Pl. 117:1 for photograph.
46	P 3057	Jug	Well made, brown ocher 3, quadruple handle (see p. 150). See Pl. 117:5 for photograph.
47	P 3060	Jug	Same as No. 45 except for closer burnishing and triple handle (see p. 150). See Pl. 117:4 for photograph.

TOMB 911 A I

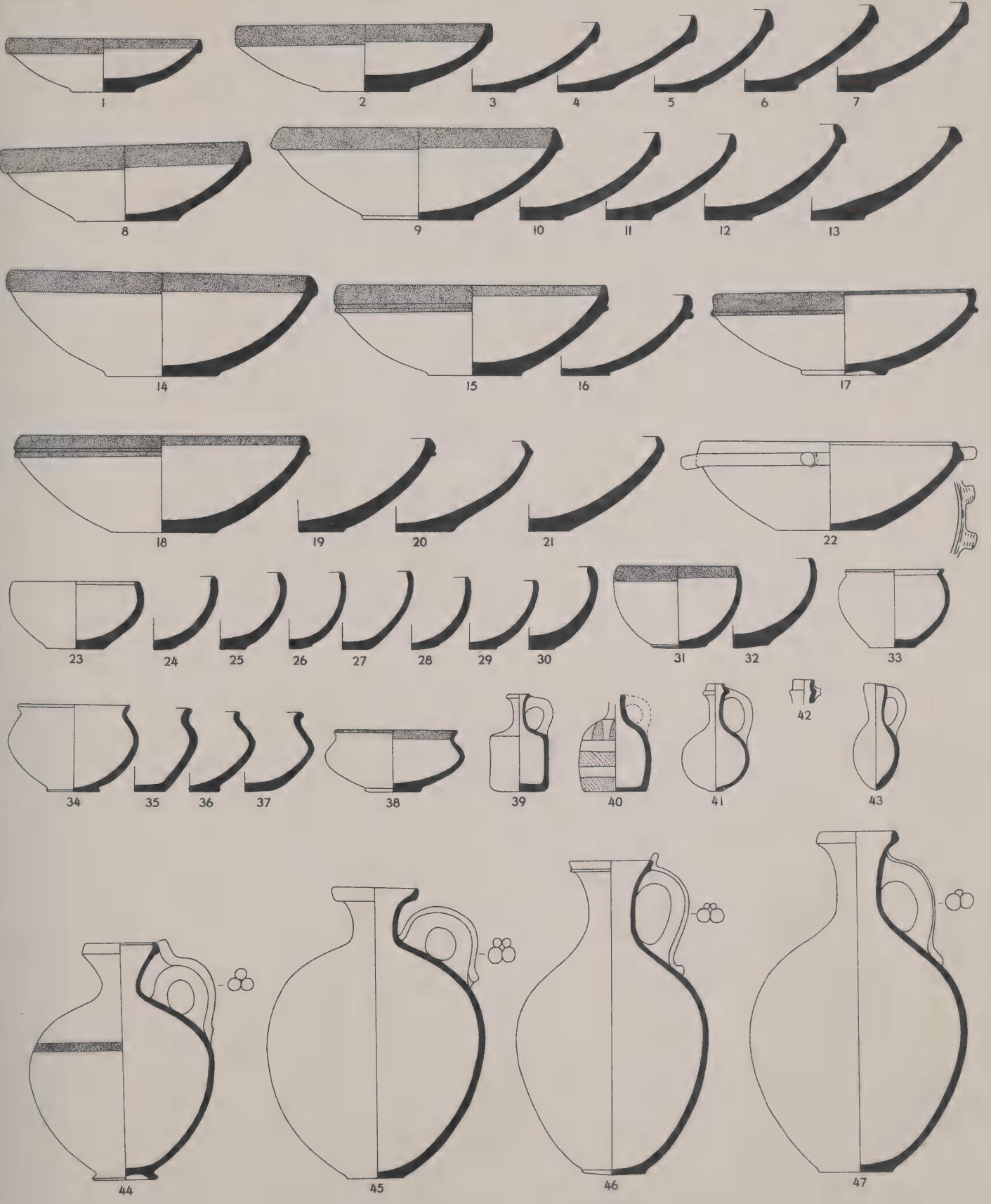

MB II POTTERY FROM TOMB 911 A I (SEE PP. 64-67). SCALE, 1:5

No.	Field No.	Designation	Description
1	P 3065	Jug	Many mixed grits, well made, brown ocher 2, light red 2 wash outside, spaced vertical burnishing on body
	P 3063 P 3072 P 3244	Jugs	Same type as No. 1; P 3063 found in P 3054 (Pl. 28:5); MB II
2	P 3104	Jug	Many mixed grits, well made, brown ocher 2, indian red 3 decoration (see p. 151)
	P 3071 P 3079 P 3095 P 3106 P 3112 P 3115 P 3225	Jugs	Same type as No. 2 (see Fig. 72); MB II
	P 3099 P 3142 P 3250 P 3253	Jugs	Same shape as No. 2 with ware like that of No. 1; MB II
3	P 3229	Jug	Same as No. 2
4	P 3213	Jug	Same as No. 2
5	P 3105	Jug	Well fired, burnt umber 3 core, burnt umber 3 to naples yellow 3 surface, indian red 3 and blue-black 3 decoration (see-p. 151). See Pl. 117:6 for photograph.
6	P 3257	Jug	Permanent brown 3, traces of indian red 2 wash and close burnishing
7	P 3058	Jug	Intact, brown ocher 2 surface. See Pl. 117:3 for photograph.
8	P 3080	Lamp	Many large mixed grits, brown ocher 3
9	P 3101	Jar	Same as No. 1. See Pl. 117:7 for photograph.
	P 3073	Jar	Same type as No. 9 except for no wash and no burnishing; MB II
10	P 3075	Jar	Many mixed grits, chiefly brown ocher 2, horizontal combing outside emphasized at shoulder for decoration
11	P 3209	Jar	Many mixed grits, burnt umber 3, indian red 3 decoration
12	P 3396	Jar	Permanent brown 3 core, naples yellow 2 surface. See Pl. 117:9 for photograph.
	P 3108	Jug	Same type as Pl. 32:1; MB II

TOMB 911 A 1

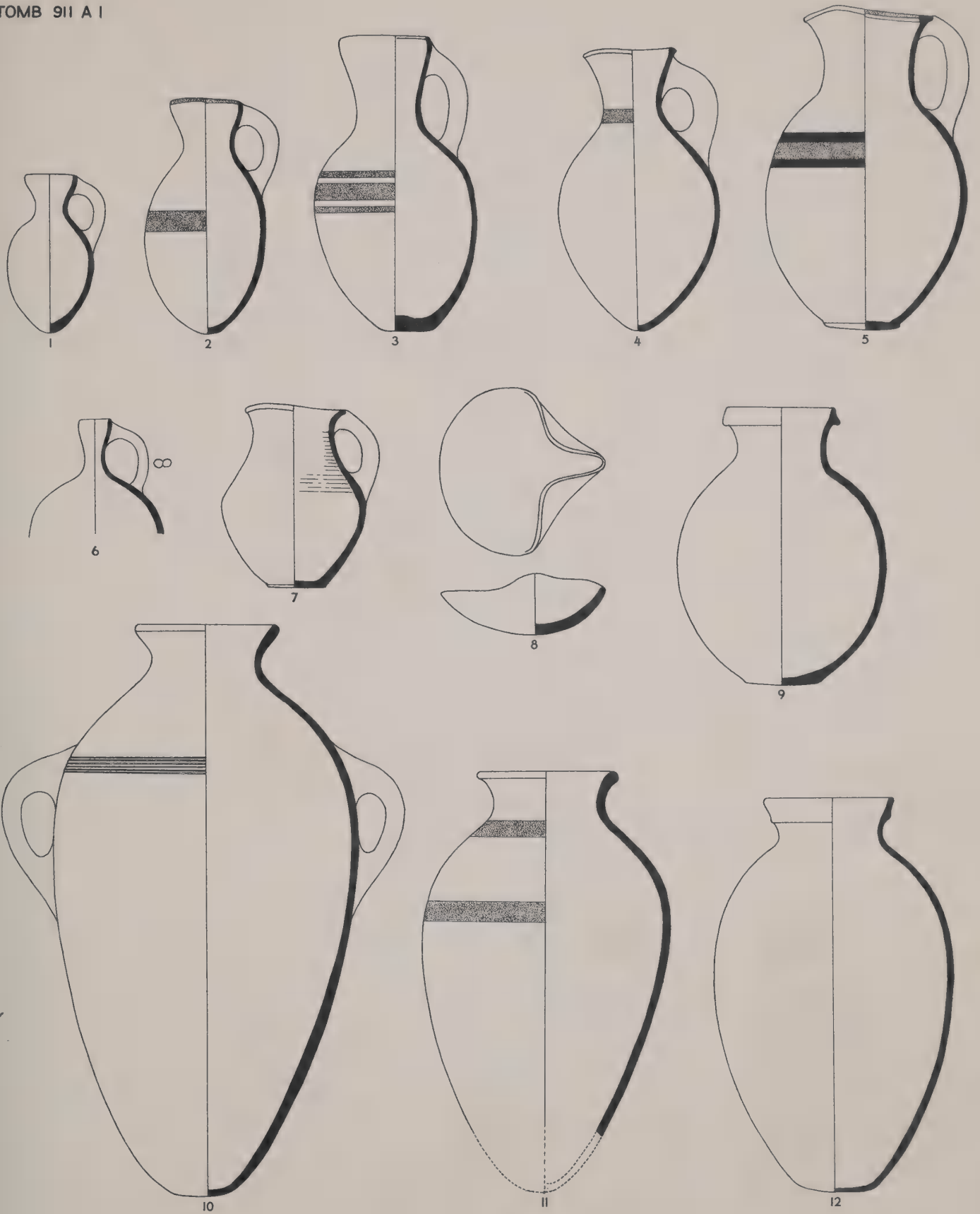

MB II POTTERY FROM TOMB 911 A 1 (SEE PP. 64-67). SCALE, 1:5

No.	Field No.	Designation	Description
1	P 3052	Bowl	Complete, many large light grits, poorly made, naples yellow 2 to burnt umber 3 surface; base discolored by oxidation from "bronze" offering-stand (Pl. 119:1) upon which it once rested. See Pl. 117:10 for photograph.
2	P 3076	Bowl	Intact, many large light grits, poorly made, burnt umber 1 to 3 surface. See Pl. 117:11 for photograph.
		Bowls (2)	Same type as No. 2; LB II
3	P 3056	Milk bowl	Fine ware, many minute mixed grits, blue-black 2 core, permanent brown 3 to brown ocher 3 surface, irregular burnishing, roman sepia 2 decoration, handmade; Cypriote (see p. 158). See Pl. 117:12 for photograph.
4	P 3053	Chalice	Well fired, permanent brown 3 core, brown ocher 2 surface. See Pl. 117:13 for photograph.
5	P 3070	Flask	Many minute mixed grits, well fired, blue-black 3 core, burnt umber 3 surface, spaced irregular burnishing, light red 2 decoration, handmade(?) (see p. 155). See Pl. 117:16 for photograph.
6	P 3066	Jug	Many mixed grits, blue-black 3 core, brown ocher 2 surface. See Pl. 117:14 for photograph.
7	P 3092	Jug	Intact, many minute dark grits, poorly made, naples yellow 2 surface, vertically shaved. See Pl. 117:15 for photograph.
8	P 3050	Jug	Same as No. 6 except for darker surface
9	P 3149	Jug	Some large mixed grits, permanent brown 3 core, chiefly burnt umber 3 surface
10	P 3077	Jug	Intact, many mixed grits, brown ocher 2. See Pl. 117:17 for photograph.
11	P 3051	Jug	Intact, brown ocher 2 surface, light red 2 decoration. See Pl. 117:18 for photograph.
12	P 3081	Jar	Same as No. 10
13	P 3067	Jar	Intact, well fired, brown ocher 2 surface
14	P 3069	Jar	Same as No. 13 except for permanent brown 3 core
15	P 3068	Jar	Blue-black 3 core, naples yellow 2 surface

TOMB 911 A 1

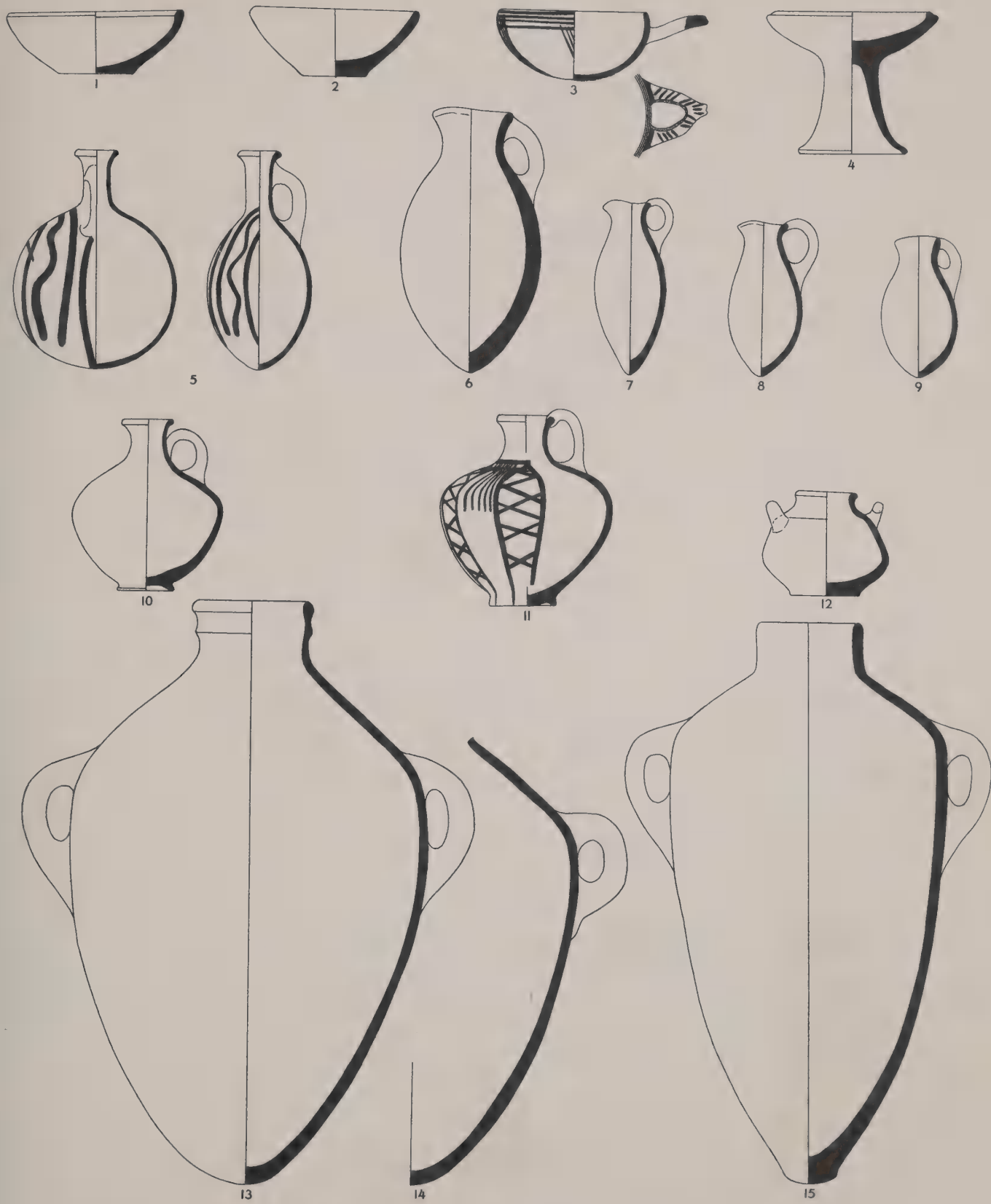

0 10 20 30 CM.

LB II POTTERY FROM TOMB 911 A 1 (SEE PP. 64-67). SCALE, 1:5

No.	Field No.	Designation	Description	Date
TOMB 911 A 2				
1	P 3114	Jug	Many minute mixed grits, naples yellow 2, handmade. See Pl. 116:16 for photograph.	MB I
	P 3217 } P 3249 }	Jugs	Same type as No. 1	MB I
2	P 3109	"Teapot"	Many minute mixed grits, burnt umber 2 core, naples yellow 2 surface, handmade. See Pl. 116:14 for photograph.	MB I
	P 3216	"Teapot"	Same type as No. 2	MB I
3	P 3110	"Teapot"	Many minute mixed grits, permanent brown 3 core, brown ocher 2 surface, handmade. See Pl. 116:15 for photograph.	MB I
TOMB 911 B				
4	P 3084	Bowl	Complete, some large mixed grits, burnt umber 1 core, brown ocher 2 surface, spaced horizontal burnishing, indian red 2 decoration (see p. 157). See Pl. 119:2 for photograph.	LB II
TOMB 911 C				
5	P 3247	Bowl	Some large light grits, poorly made, brown ocher 2. See Pl. 120:1 for photograph.	LB II
6	P 3232	Bowl	Intact, many mixed grits, brown ocher 3 surface, light red 2 wash over rim. See Pl. 120:2 for photograph.	MB II
7	P 3116	Chalice	Some large mixed grits, brown ocher 3. See Pl. 120:3 for photograph.	LB II
TOMB 911 D				
8	P 3119	Bowl	Intact, many mixed grits, brown ocher 2 surface, light red 2 wash over rim. See Pl. 121:3 for photograph.	MB II
	P 3117	Bowl	Same type as No. 8	MB II
9	P 3127	Bowl	Complete; same as No. 8	MB II
	P 3122 } P 3134 }	Bowls	Same type as No. 9	MB II
	P 3132	Bowl	Same type as No. 9, with additional band of light red 2 wash below rim	MB II
10	P 3130	Bowl	Same as No. 8 except for vertical burnishing inside	MB II
11	P 3135	Bowl	Same as No. 8 except for light red 2 wash inside. See Pl. 121:4 for photograph.	MB II
12	P 3129	Bowl	Same as No. 8	MB II
13	P 3128	Bowl	Intact; same as No. 8 except for light red 2 wash over entire inside surface and vertical burnishing. See Pl. 121:1 for photograph.	MB II
14	P 3118	Bowl	Same as No. 8 except for brown ocher 3 surface	MB II
15	P 3136	Bowl	Many mixed grits, brown ocher 3, light red 2 wash over rim, close horizontal burnishing outside	MB II
16	P 3248	Jug	Many mixed grits, brown ocher 3 core, black lead 3 surface, light red 2 to brown ocher 2 wash, close vertical burnishing	MB II
17	P 3238	Jug	Same as No. 16. See Pl. 121:9 for photograph.	MB II
18	P 3131	Jug	Many mixed grits, well made, well fired, brown ocher 2, blue-black 2 and indian red 2 decoration (see pp. 150 f.)	MB II
19	P 3125	Jug	Intact, well made, brown ocher 2 surface, indian red 2 decoration (see pp. 150 f.). See Pl. 121:5 for photograph.	MB II
20	P 3124	Jug	Many mixed grits, well made, brown ocher 2, indian red 3 wash, spaced vertical burnishing (see p. 150)	MB II
21	P 3120	Jug	Many mixed grits, well made, brown ocher 3, indian red 2 and blue-black 3 decoration (see pp. 150 f.)	MB II

TOMB 911 A 2

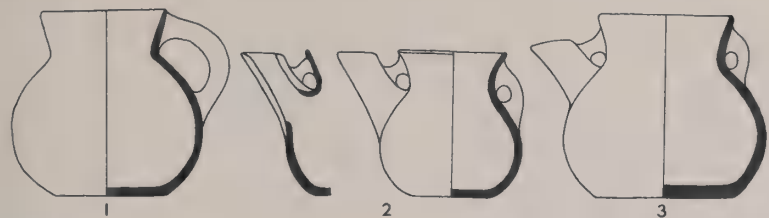

TOMB 911 B

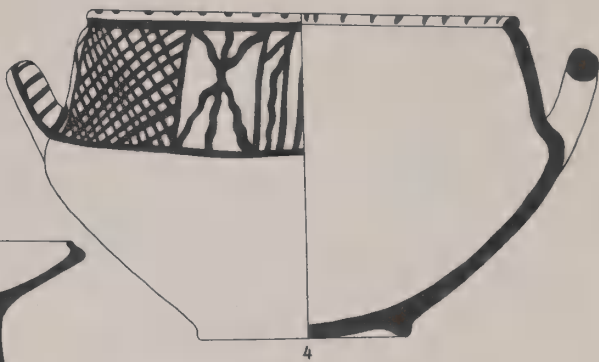

TOMB 911 C

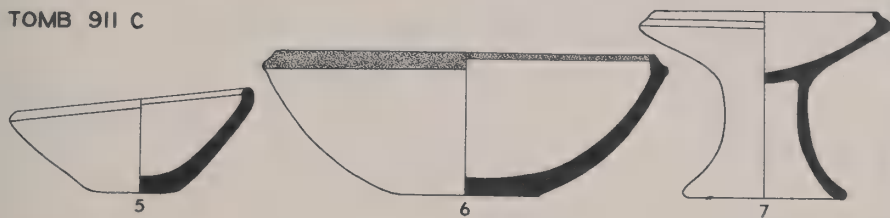

TOMB 911 D

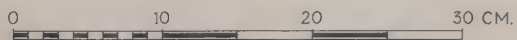
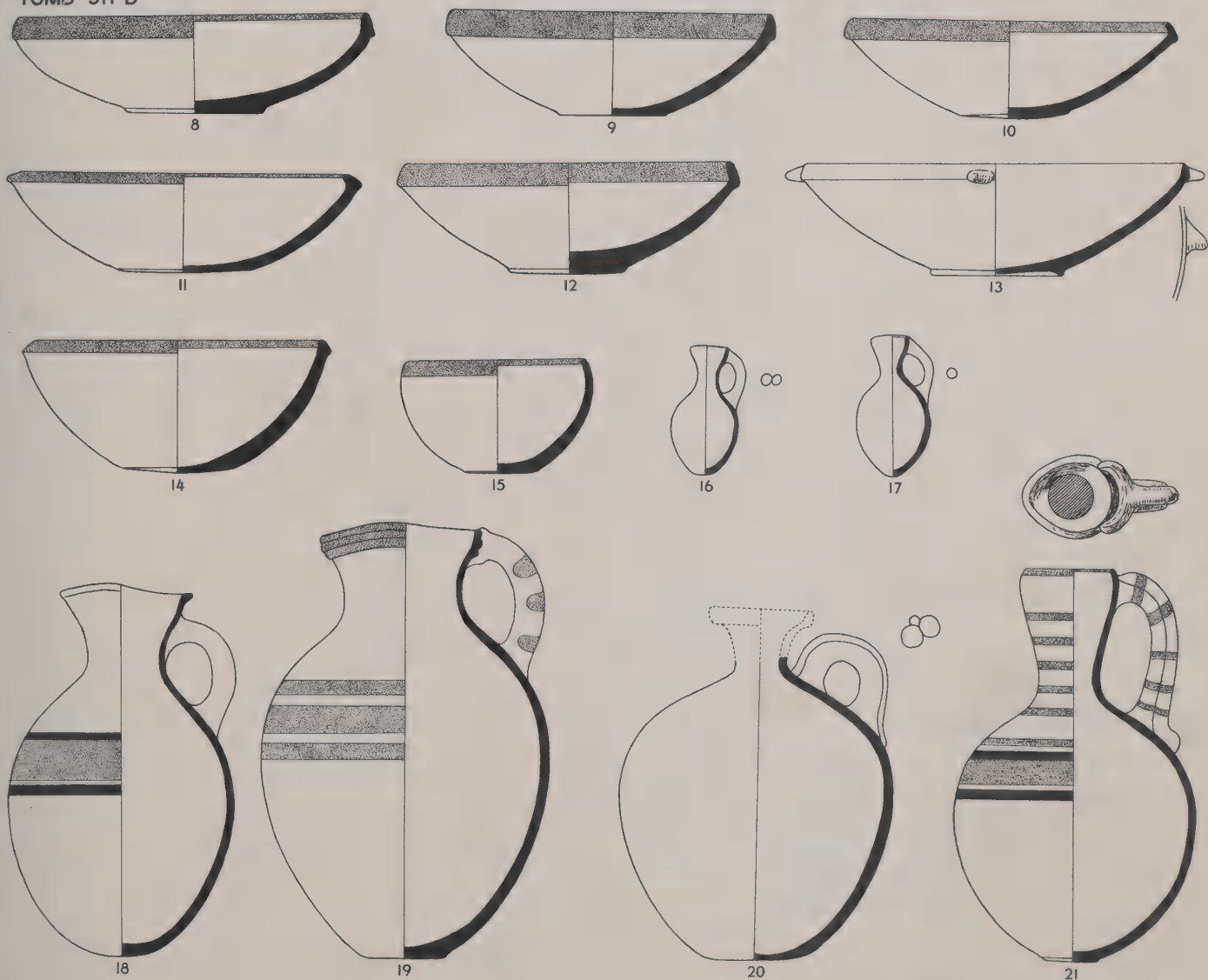

MB and LB II POTTERY FROM TOMB 911 (SEE PP. 64-68). SCALE, 1:5

No.	Field No.	Designation	Description
TOMB 911 D			
1	P 3121	Jug	Intact, many mixed grits, well fired, well made, brown ocher 2 surface. See Pl. 121:7 for photograph.
2	P 3123	Jug	Intact; same as No. 1 except for decorative combing. See Pl. 121:6 for photograph.
3	P 3133	Lamp	Many mixed grits, lightly fired, brown ocher 2. See Pl. 121:8 for photograph.
TOMB 912 SHAFT			
4	P 3139	Bowl	Brown ocher 2
	P 3138	Bowl	Same type as No. 4; LB II
5	P 3266	Bowl	Some minute mixed grits, permanent brown 3 core, brown ocher 3 surface, indian red 2 wash over rim
6	P 3549	Bowl	Permanent brown 3 core, burnt umber 3 surface, purple madder 2 decoration, double thumb handle
7	P 3550	Jar	Fine ware, some minute mixed grits, well made, permanent yellow 2, vandyke brown 3 decoration, close horizontal burnishing; Mycenaean; reconstruction theoretical
8	P 3551	"Cup and saucer"	Same as No. 4
9	P 3564	Lamp	Many mixed grits, well fired brown ocher 2
	P 3561 } P 3563 }	Lamps	Same type as No. 9; LB II
10	P 3565	Lamp	Well fired, blue-black 2 core, burnt umber 3 surface
11	P 3562	Lamp	Same as No. 10
	P 3137	Lamp	Same type as No. 11 (see Fig. 75); LB II
TOMB 912 A 1			
12	P 3432	Bowl	Many predominantly light grits, brown ocher 2 (see p. 155)
	P 3429	Bowl	Same type as No. 12; LB II
13	P 3426	Bowl	Same as No. 12. See Pl. 123:10 for photograph.
	P 3449	Bowl	Same type as No. 13; LB II
14	P 3428	Bowl	Same as No. 12
15	P 3425	Bowl	Same as No. 12 except for indian red 2 wash over rim
	P 3448	Bowl	Same type as No. 15; LB II
16	P 3433	Bowl	Intact; same as No. 12
	P 3431 } P 3435-36 } P 3438 } P 3451 }	Bowls	Same type as No. 16; LB II
17	P 3446	Bowl	Many large light grits, blue-black 2 core, burnt umber 3 surface (see p. 155)
18	P 3437	Bowl	Complete, many large mixed grits, brown ocher 2 surface (see p. 155)
19	P 3440	Bowl	Some large light grits, chiefly naples yellow 2 (see p. 155)
20	P 3427	Bowl	Intact; same as No. 12. See Pl. 123:9 for photograph.
21	P 3423	Bowl	Same as No. 12 except for permanent brown 3 core and thumb handle. See Pl. 123:8 for photograph.
22	P 3453	Bowl	Intact, many light grits, brown ocher 3 surface, faded indian red 3 decoration; contained "bronze" bowl (Pl. 123:19). See Pl. 123:12 for photograph.
23	P 3452	Bowl	Intact, many large mixed grits, chiefly burnt umber 3 surface, indian red 2 decoration

TOMB 911 D

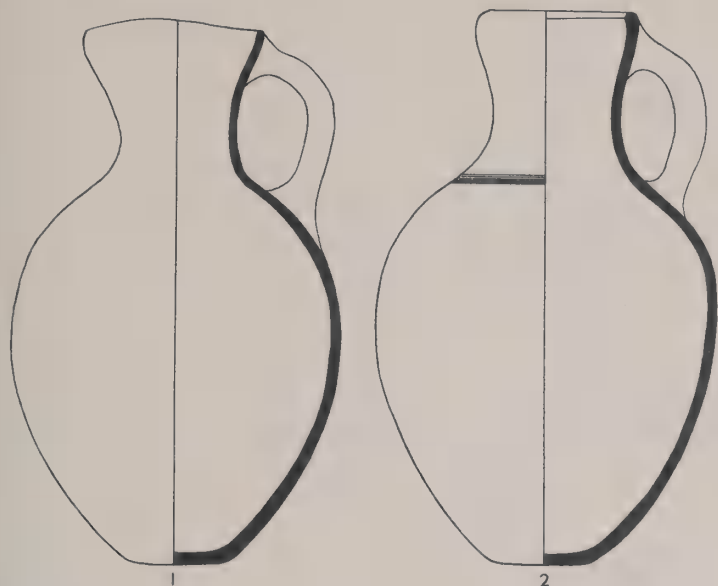

TOMB 912 SHAFT

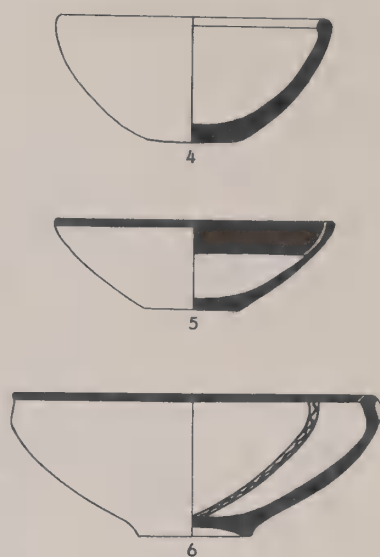

TOMB 912 SHAFT

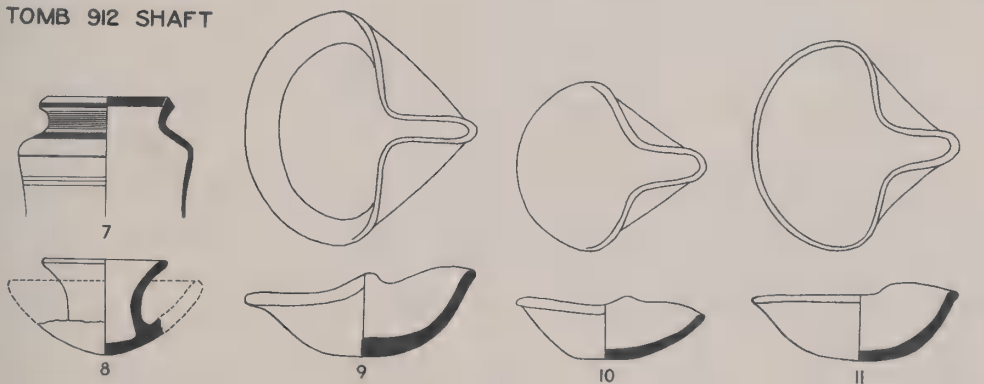

TOMB 912 A1

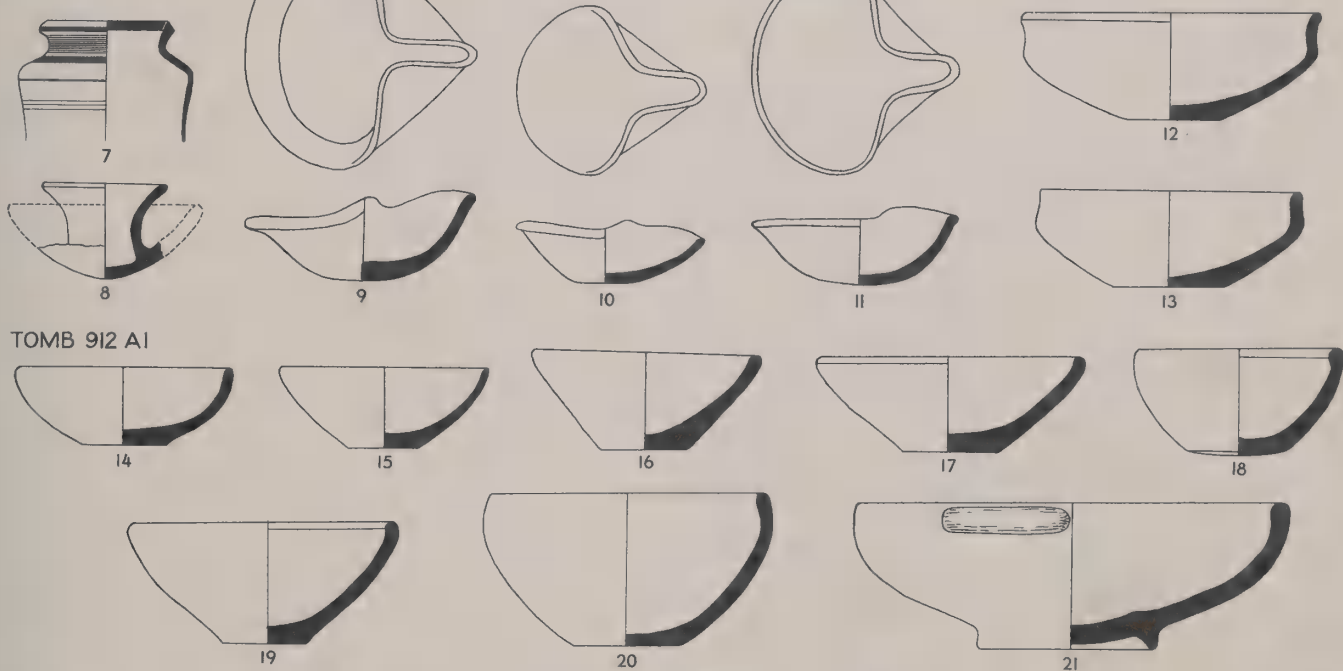

TOMB 912 A1



No.	Field No.	Designation	Description	Date
TOMB 912 A 1				
1	P 3447	Jug	Intact, few mixed grits, brown ocher 3 surface. See Pl. 123:14 for photograph.	LB II
	P 3443	Jug	Same type as No. 1	LB II
2	P 3444	Jug	Many mixed grits, brown ocher 1, traces of indian red 3 wash and vertical burnishing; probably intrusive from chamber B	MB II
3	P 3439	Jug	Intact, few minute dark grits, naples yellow 1 surface, vertical shaving	LB II
	P 3442	Jug	Same type as No. 3	LB II
4	P 3445	Jug	Blue-black 3 core, chiefly naples yellow 2 surface. See Pl. 123:17 for photograph.	LB II
5	P 3454	Jug	Brown ocher 2. See Pl. 123:16 for photograph.	LB II
6	P 3434	Lamp	Many mixed grits, burnt umber 2	LB II
	P 3450	Lamp	Same as No. 6 except for blue-black 3 core	LB II
7	P 3458	Jar	Some light grits, well fired, permanent brown 1 core, naples yellow 2 surface, pottery mark	LB II
8	P 3455	Jar	Intact; same as No. 7. See Pl. 123:13 for photograph.	LB II
TOMB 912 A 2				
9	P 3459	Jug	Many minute mixed grits, well made, burnt umber 3 core, naples yellow 2 surface, pinched lip, handmade (see p. 149). See Pl. 123:1 for photograph.	MB I
10	P 3548	"Teapot"	Fine ware, many minute light grits, well made, well fired, indian red 3 core, blue-black 3 surface, naples yellow 3 decoration (see p. 148). See Pl. 123:3 for photograph.	MB I
11	P 3460	Jar	Many minute mixed grits, naples yellow 2, inside and part of outside coated with carbonized substance, hole in base made before carbonization, handmade. See Pl. 123:2 for photograph.	MB I

TOMB 912 A 1

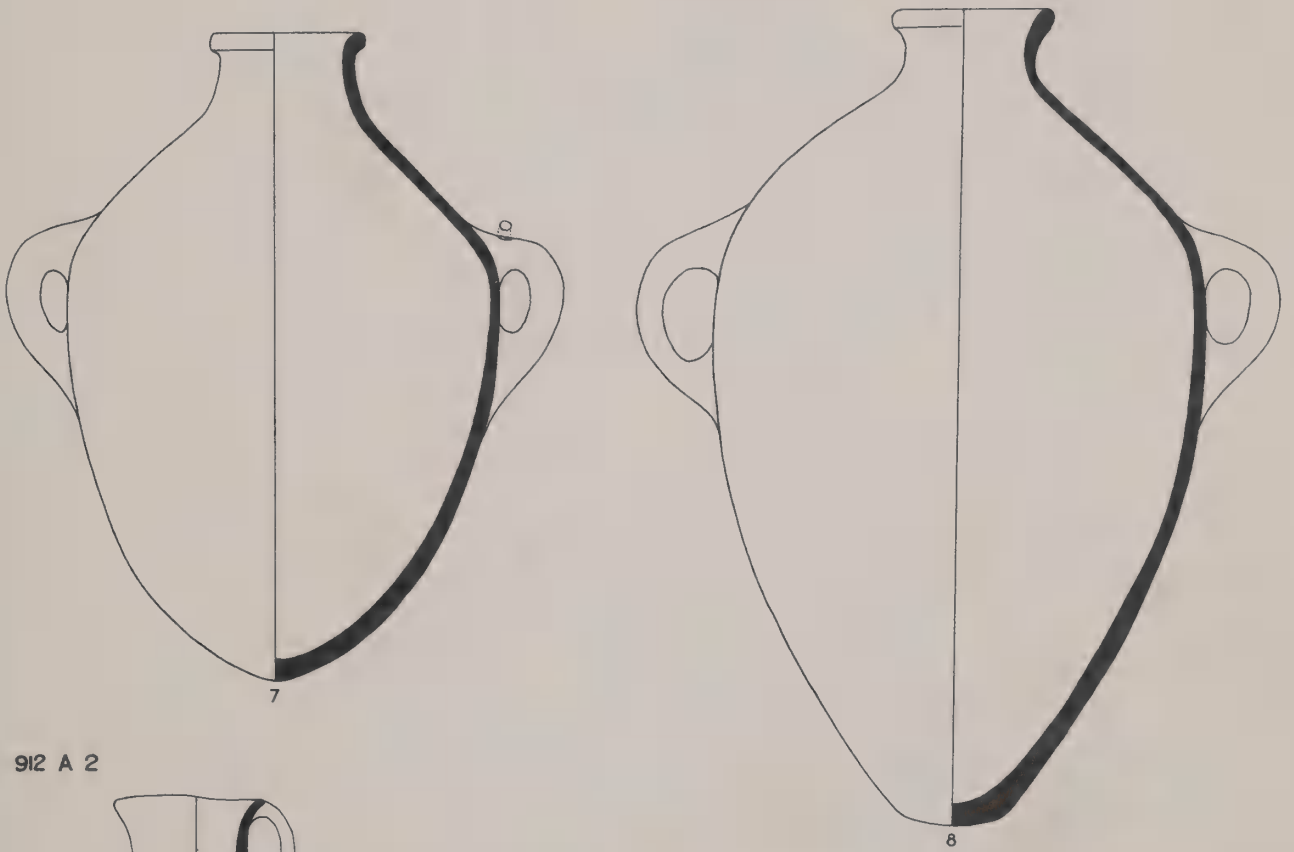
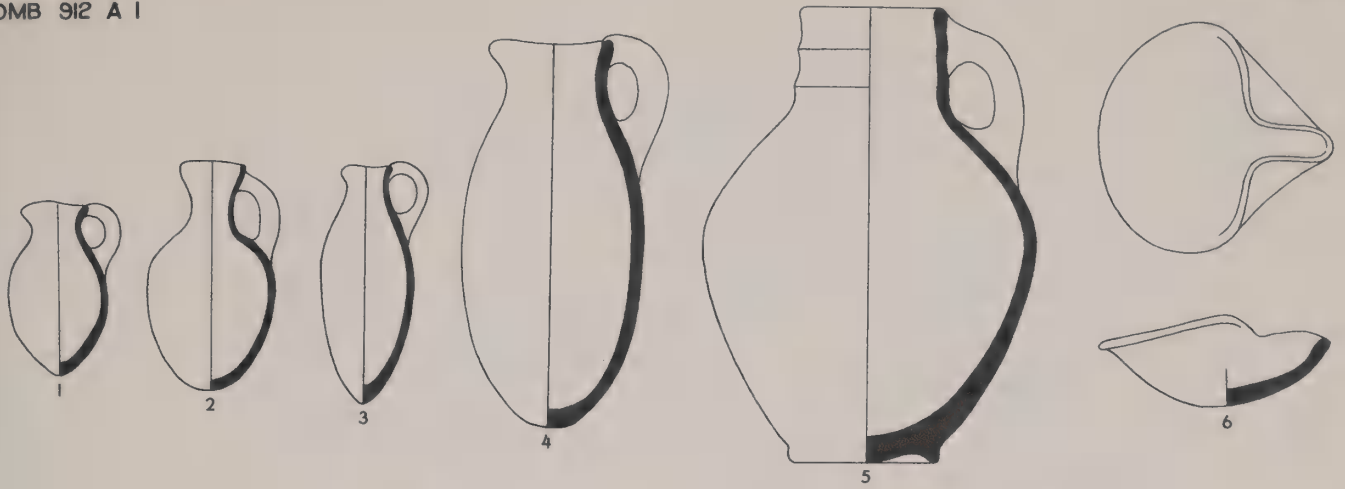

TOMB 912 A 2

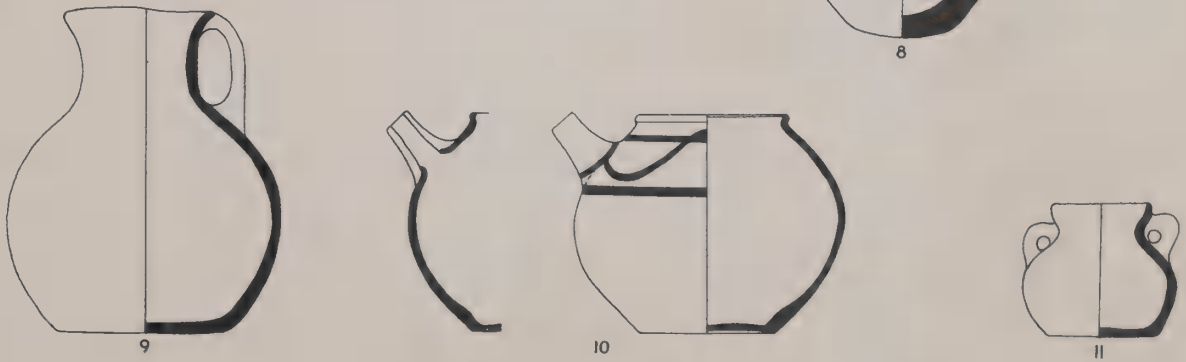

MB AND LB II POTTERY FROM TOMB 912 A (SEE PP. 69-72). SCALE, 1:5

No.	Field No.	Designation	Description
1	P 3527	Bowl	Many predominantly light grits, well fired, blue-black 3 core, burnt umber 2 surface
	P 3501 P 3515 P 3525	Bowls	Moderately fired specimens of same type as No. 1 (see Fig. 78); LB II
2	P 3535	Bowl	Intact, brown ocher 2 surface
	P 3503 P 3518 P 3529 P 3531 P 3540 P 3567	Bowls	Same type as No. 2 with minor variations in firing or color (see Fig. 78); LB II
3	P 3538	Bowl	Many mixed grits, lightly fired, brown ocher 3
4	P 3528	Bowl	Many predominantly light grits, brown ocher 2
5	P 3526	Bowl	Same as No. 4
6	P 3519	Bowl	Intact, well made, brown ocher 3 surface, spaced horizontal burnishing outside, thumb handle
	P 3533	Bowl	Same type as No. 6 except for permanent brown 3 core and traces of indian red 3 wash; contained weight (Pl. 129:10); LB II
	P 3544	Bowl	Same type as No. 6 except for blue-black 3 core; LB II
7	P 3513	Bowl	Well fired, naples yellow 3, indian red 3 decoration (see p. 157). See Pl. 124:12 for photograph.
8	P 3514	Bowl	Intact, many mixed grits, brown ocher 2 surface, indian red 2 decoration
9	P 3516	Bowl	Intact, many light grits, brown ocher 3 surface, blue-black 3 decoration superimposed on indian red 2; Mycenaean(?). See Pl. 124:8 for photograph; see Fig. 78 for association with jar-stand No. 20.
10	P 3537	Bowl	Some light grits, blue-black 2 core, brown ocher 2 surface
11	P 3502	Chalice	Light grits, permanent brown 3 core, brown ocher 2 surface (see p. 154). See Pl. 124:17 for photograph.
12	P 3521	Chalice	Intact, many mixed grits, well fired, burnt umber 2 surface, blackened by fire inside (see p. 154). See Pl. 124:16 for photograph.
13	P 3522	Flask	T. .085, burnt umber 3, traces of close burnishing, indian red 3 decoration (see p. 155)
14	P 3509	Flask	T. .057, few light grits, brown ocher 2, indian red 3 decoration (see p. 155). See Pl. 124:14 for photograph.
15	P 3524	Flask	Intact, t. .065, many light grits, brown ocher 2 surface, traces of close burnishing, indian red 3 spiral decoration (see p. 155)
16	P 3566	Flask	T. .060, many minute mixed grits, permanent brown 1 core, brown ocher 3 surface, traces of close burnishing, indian red 3 decoration (see p. 155). See Pl. 124:15 for photograph.
17	P 3523	Jug	Intact, many minute mixed grits, well made, well fired, chiefly brown ocher 3 surface, indian red 3 to sepia 1 decoration. See Pl. 124:11 for photograph.
18	P 3500	Jug	Many large mixed grits, brown ocher 2. See Pl. 124:10 for photograph.
19	P 3536	Jug	Intact, many mixed grits, brown ocher 3 surface, thumb mark. See Pl. 124:9 for photograph.
20	P 3512	Jar-stand	Intact, many mixed grits, brown ocher 2 surface. See Pl. 124:19 for photograph; see Fig. 78 for association with bowl No. 9.
21	P 3520	Stirrup cup	Fine ware, well made, brown ocher 2, traces of horizontal burnishing, indian red 2 decoration; Mycenaean (see p. 157). See Pl. 124:18 for photograph.
22	P 3546	Stirrup cup	Fine ware, few minute light grits, well made, brown ocher 3, close horizontal burnishing, indian red 2 decoration; Mycenaean (see p. 157)
	P 3510 P 3543 P 3569-71	Stirrup cups	Same type as No. 22; LB II
23	P 3517	Jar	Blue-black 3 core, brown ocher 2 surface, traces of horizontal burnishing, indian red 3 decoration (see p. 157)

TOMB 912 B

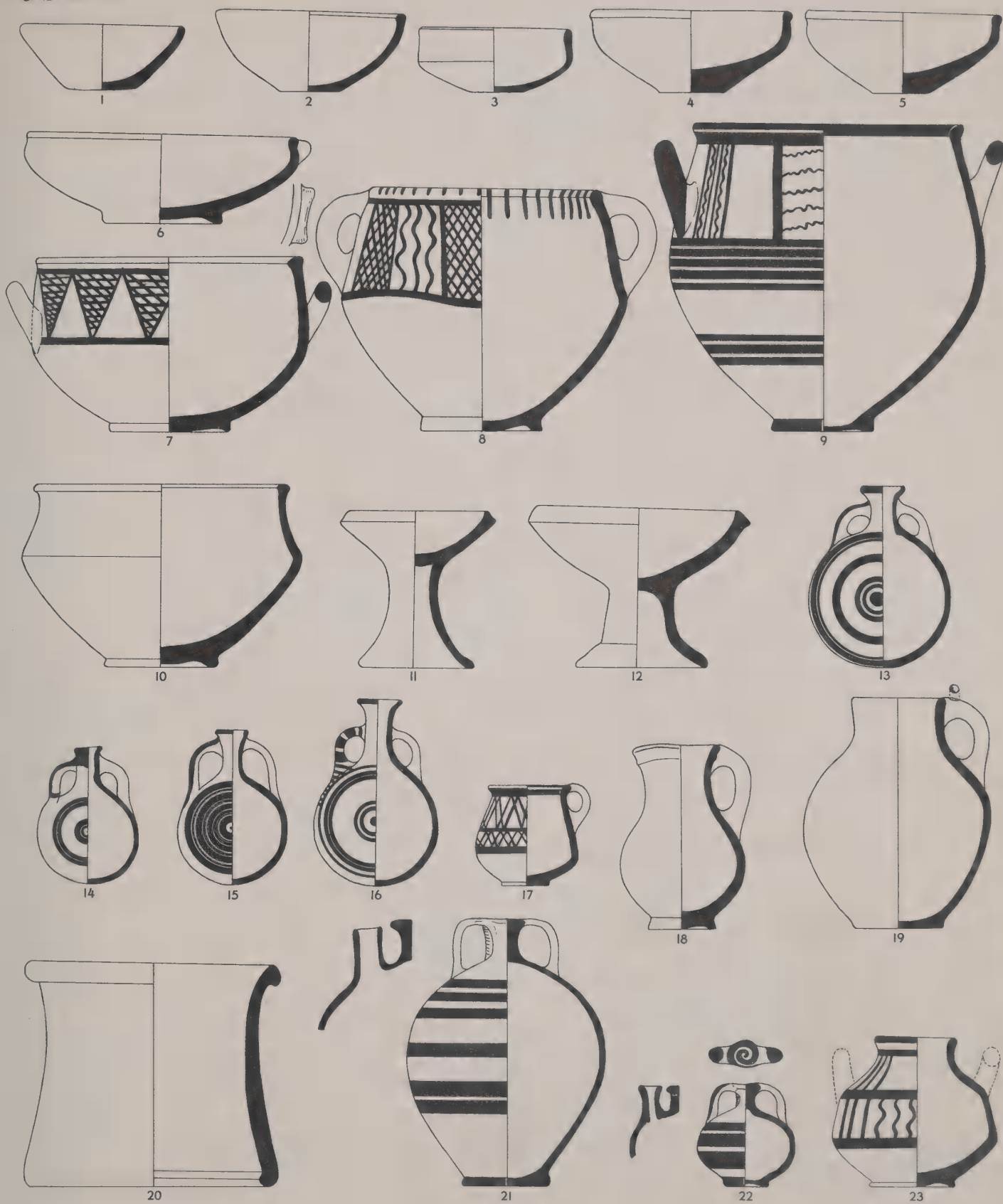

0 10 20 30 CM.

LB II POTTERY FROM TOMB 912 B (SEE P. 72). SCALE, 1:5

No.	Field No.	Designation	Description	Date
TOMB 912 B				
1	P 3530	Bowl	Many mixed grits, burnt umber 3, indian red 3 wash outside and over rim, spaced vertical burnishing, small knob outside below rim. See Pl. 124:1 for photograph.	MB II
	P 3511	Bowl	Same type as No. 1	MB II
2	P 3534	Bowl	Intact, many light grits, brown ocher 3 surface. See Pl. 124:2 for photograph.	MB II
3	P 3508	Bowl	Intact, many mixed grits, brown ocher 2 surface, light red 2 wash over rim. See Pl. 124:3 for photograph.	MB II
	P 3539	Bowl	Same type as No. 3; contained 3 "bronze" objects (Pls. 126:15, 127:4, 129:9)	MB II
4	P 3545	Bowl	Blue-black 3 core, brown ocher 2 surface, 2 handles projecting from rim	MB II
5	P 3541	Jar	Intact, well made, brown ocher 2 surface, indian red 3 decoration. See Pl. 124:7 for photograph.	MB II
6	P 3507	Jug	Same as No. 5. See Pl. 124:6 for photograph.	MB II
7	P 3532	Jug	Some minute mixed grits, well made, brown ocher 2, indian red 3 wash outside and over rim, spaced vertical burnishing. See Pl. 124:5 for photograph.	MB II
8	P 3572	Jug	Same as No. 7	MB II
	P 3547	Jug	Same type as No. 8	MB II
9	P 3573	Jug	Few minute light grits, naples yellow 2 core, warm sepia 2 surface, traces of close burnishing and indian red 3 decoration	MB II
10	P 3542	Jug	Same as No. 7. See Pl. 124:4 for photograph.	MB II
	P 3574	Jar	Light red 2 wash, spaced vertical burnishing, horizontally pierced lug handle; intrusive	EB
TOMB 912 D				
11	P 3496	Bowl	Intact, brown ocher 2 surface, light red 2 wash over rim	MB II
12	P 3555	Bowl	Fine ware, few minute light grits, well made, naples yellow 2, indian red 3 wash outside, close vertical burnishing	MB II
13	P 3556	Bowl	Many light grits, permanent brown 3 core, brown ocher 2 inside surface, indian red 3 wash outside and over rim, spaced vertical burnishing	MB II
14	P 3466	Bowl	Same as No. 3 except for no wash; contained bracelet (Pl. 133:21)	MB II
15	P 3481	Bowl	Intact; same as No. 3 except for no wash	MB II
16	P 3499	Bowl	Intact; same as No. 3 except for additional band of light red 2 wash outside and traces of vertical burnishing inside	MB II
17	P 3505	Jug	Same as No. 5	MB II
18	P 3464	Jug	Same as No. 7. See Pl. 133:2 for photograph.	MB II
19	P 3483	Jug	Same as No. 7. See Pl. 133:3 for photograph.	MB II
20	P 3487	Jar-stand	Blue-black 3 core, naples yellow 2 surface (see p. 154). See Pl. 133:14 for photograph; see Fig. 80 for association with bowl No. 30.	LB II
21	P 3467	Jar	Well fired, burnt umber 2 (see p. 157). See Pl. 133:9 for photograph.	LB II
22	P 3560	Stirrup cup	Fine ware, few minute light grits, well made, well fired, burnt umber 3 core, naples yellow 1 surface, close horizontal burnishing, indian red 1 decoration; Mycenaean	LB II
23	P 3471	Funnel	Some light grits, permanent brown 3 core, naples yellow 2 surface. See Pl. 133:13 for photograph.	LB II
24	P 3559	"Cup and saucer"	Many mixed grits, poorly made, blue-black 3 core, brown ocher 1 surface (see p. 155). See Pl. 133:18 for photograph.	LB II
25	P 3498	Milk bowl	Fine ware, few minute light grits, well made, well fired, warm sepia 3 core, brown ocher 2 surface, handmade; Cypriote (see p. 158). See Pl. 133:17 for photograph.	LB II
26	P 3461	Jar	Brown ocher 2, indian red 2 decoration. See Pl. 133:12 for photograph.	LB II
27	P 3478	Jug	Intact, many light grits, brown ocher 3 surface, wet-smoothed after shaving. See Pl. 133:10 for photograph.	LB II
28	P 3474	Chalice	Well fired, brown ocher 2 surface. See Pl. 133:15 for photograph.	LB II
29	P 3482	Lamp	Intact, some light grits, poorly made, brown ocher 2 surface (see p. 156). See Pl. 133:16 for photograph.	LB II
30	P 3484	Bowl	Intact, many light grits, well fired, burnt umber 2 surface, indian red 2 decoration (see p. 157). See Pl. 133:8 for photograph; see Fig. 80 for association with jar-stand No. 20.	LB II

TOMB 912 B

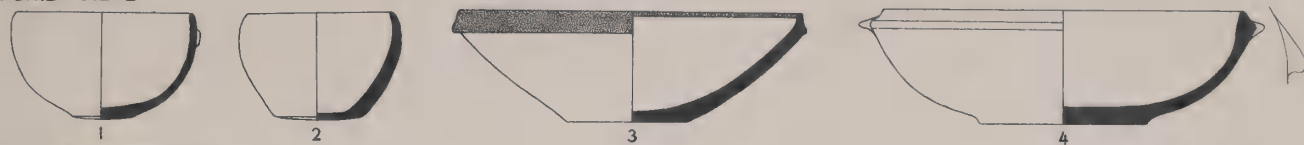

TOMB 912 D

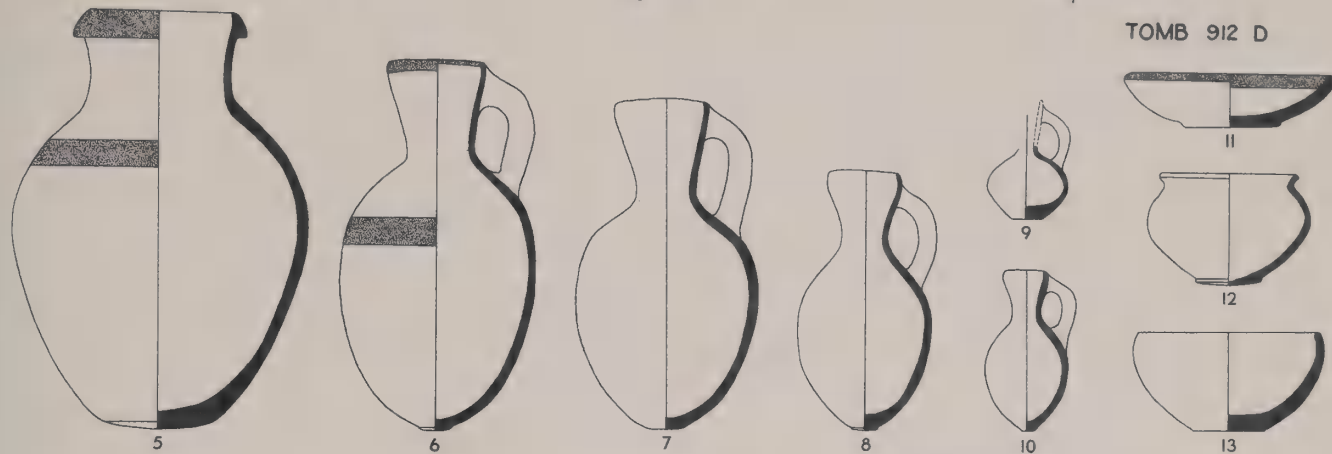

TOMB 912 D

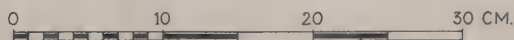
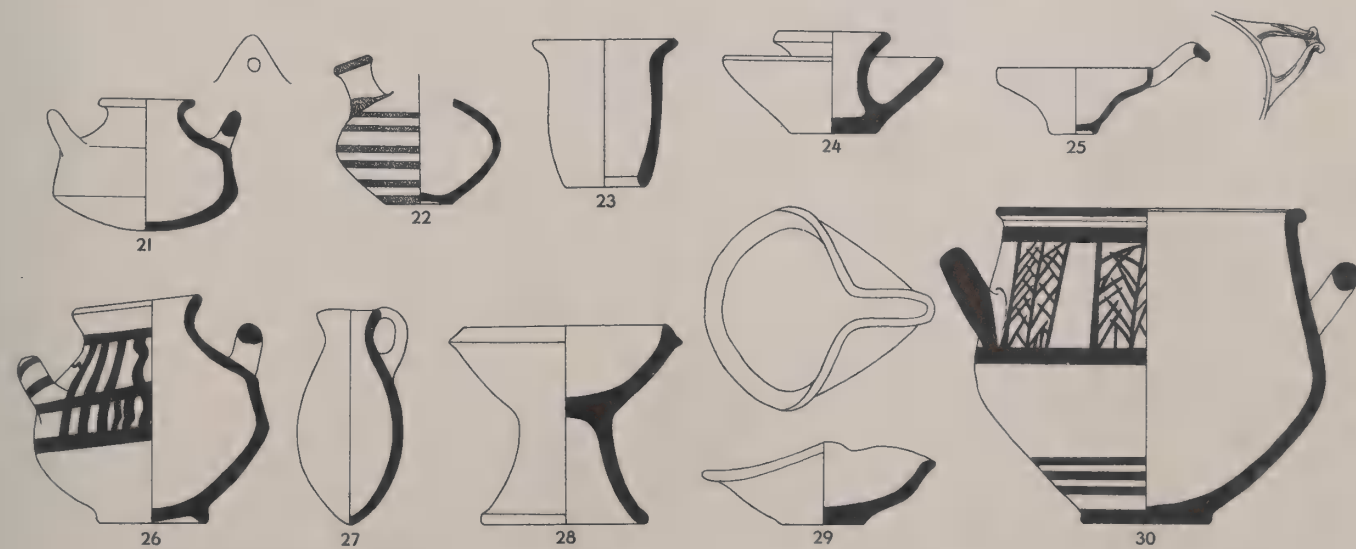
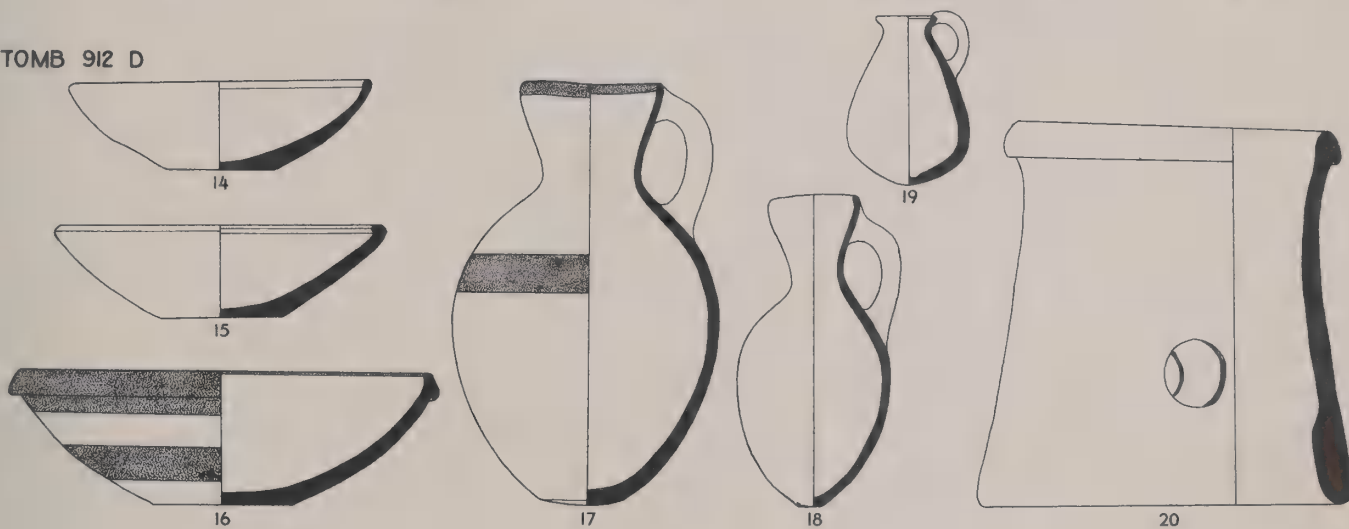

MB II AND LB II POTTERY FROM TOMB 912 (SEE PP. 69-72). SCALE, 1:5

No.	Field No.	Designation	Description
1	P 3476	Bowl	Intact, many predominantly light grits, brown ocher 2 surface (see p. 155)
	P 3465	Bowls	Same type as No. 1 with minor variations in grits and color (see Fig. 80); LB II
	P 3472		
	P 3475		
	P 3477		
	P 3485-86		
	P 3492		
	P 3557		
2	P 3463	Bowl	Intact, many light grits, well fired, burnt umber 2 surface (see p. 155)
3	P 3462	Bowl	Intact, brown ocher 1 surface (see p. 155)
4	P 3491	Bowl	Many mixed grits, well fired, blue-black 3 core, burnt umber 2 surface (see p. 155)
5	P 3480	Bowl	Intact, some light grits, well fired, brown ocher 2 surface (see p. 155)
	P 3479	Bowls	Same type as No. 5 except for many large mixed grits and roman sepia 2 core; LB II
	P 3494		
	P 3497		
6	P 3468	Bowl	Many light grits, blue-black 3 core, brown ocher 2 surface
7	P 3469	Cooking bowl	Many light grits, lightly fired, blue-black 3 core, chiefly burnt umber 1 surface, blackened by fire (see p. 155). See Pl. 133:11 for photograph.
8	P 3554	Cooking bowl	Many large light grits, lightly fired, burnt umber 1, blackened by fire (see p. 155)
	P 3470	Bowls	Same type as Pl. 35:3 with minor variations in color (see Fig. 80); LB II
	P 3473		
	P 3488-90		
	P 3495		
	P 3506		
	P 3558		

TOMB 912 D

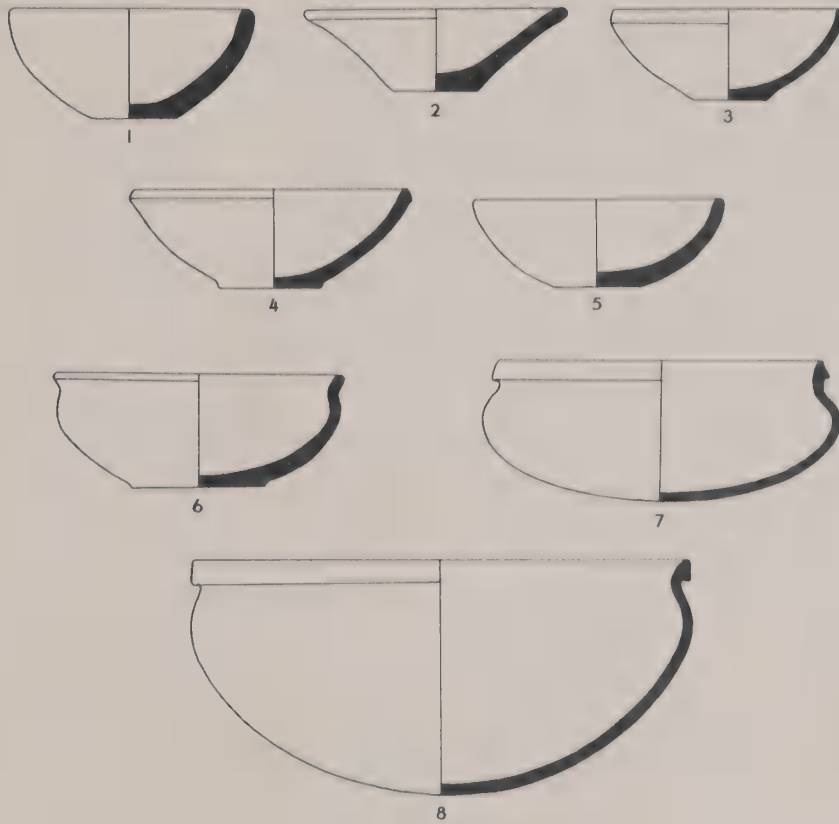

LB II POTTERY BOWLS FROM TOMB 912 D (SEE P. 72). SCALE, 1:5

No.	Field No.	Designation	Description	Date
1	x 2840	Bowl	Brown ocher 2 core, brown ocher 3 surface (see p. 152)	LB I
2	x 25	Bowl	Charcoal gray 3 core, brown ocher 3 surface	LB II
	x 11-13 x 16 x 18-20 x 23-24 x 26-27 x 48 x 62	Bowls	Same type as No. 2	LB II
3	x 2839	Bowl	Blue-black 3 core, brown ocher 3 surface, 2 handles (see p. 152)	LB I
4	x 57	Cooking bowl	Dark grits, blue-black 3 core, burnt umber 3 surface	LB
	x 38-39 x 51 x 56 x 59 x 81 x 2837	Cooking bowls	Same type as No. 4	LB
5	x 10	Bowl	Brown ocher 2 core, brown ocher 3 surface	LB II
	x 17 x 28 x 63	Bowls	Same type as No. 5	LB II
6	x 36	Cooking bowl	Dark grits, blue-black 3 core, burnt umber 1 surface	LB
7	x 2845	Bowl	Large mixed grits, blue-black 1 core, charcoal gray 3 surface (see p. 152); spout broken away. See Pl. 135:8 for photograph.	LB I
8	x 2835	Bowl	Large mixed grits, charcoal gray 3 core, brown ocher 3 surface	LB
9	x 2836	Bowl	Blue-black 2 core, brown ocher 3 surface	LB I
	x 9 x 31 x 35	Bowls	Same type as No. 9	LB I
10	x 14	Bowl	Charcoal gray 3 core, brown ocher 2 surface	LB I
11	x 4	Bowl	Large mixed grits, blue-black 3 core, brown ocher 3 surface (see p. 152)	LB I
	x 1-3 x 21 x 29-30 x 33	Bowls	Same type as No. 11	LB I
12	x 52	Jar	Many mixed grits, poorly made, charcoal gray 3 surface, handmade, possibly coil-built	LB II
13	x 54	Funnel or jar-stand*	Blue-black 2 core, light red 3 surface, handmade, coil-built	LB II
14	x 22	"Cup and saucer"	Charcoal gray 3 core, brown ocher 3 surface	LB II
15	x 84	Chalice	Brown ocher 3 core, burnt umber 2 surface	LB II
	x 79	Chalice	Same type as No. 15	LB II
	x 49 x 58	Bowls	Same type as Pl. 58:2; x 58 has a lip on the rim	LB II
	x 60	Jar	Same shape as Pl. 18:2, charcoal gray 1 core, light red 3 surface, indian red 2 decoration on shoulder and handles, coil-built	LB II
	x 61	Jar	Same type as Pl. 55:8	LB II
	x 72-73	Jars	Same type as Pl. 56:10	LB II
	x 74	Bowl	Burnt umber 3, light red 1 slip, polished horizontally outside	LB II
	x 87-88	Bilbils	Same type as Pl. 56:8	LB II
	x 89	Bowl	Same type as Pl. 56:3	LB II
	x 95	Jar	Brown ocher 2, coil-built, scraped surface	LB II
	x 98	Bowl	Same type as Pl. 32:22	LB II
	x 2841-42	Lamps	Same type as Pl. 123:11	LB II
	x 118	Bowl	Charcoal gray 1 core, light red 1 surface	LB
	x 117	Flask	Same type as Pl. 68:10	EI I
	x 119	Bowl	Same shape as Pl. 8:22, brown ocher 3 core, burnt umber 3 surface, Naples yellow 3 slip, burnt umber 2 spiral decoration on body, horizontal loop handles; Philistine (see p. 159)	EI I

\* Drawing upside down for jar-stand.

TOMB 3

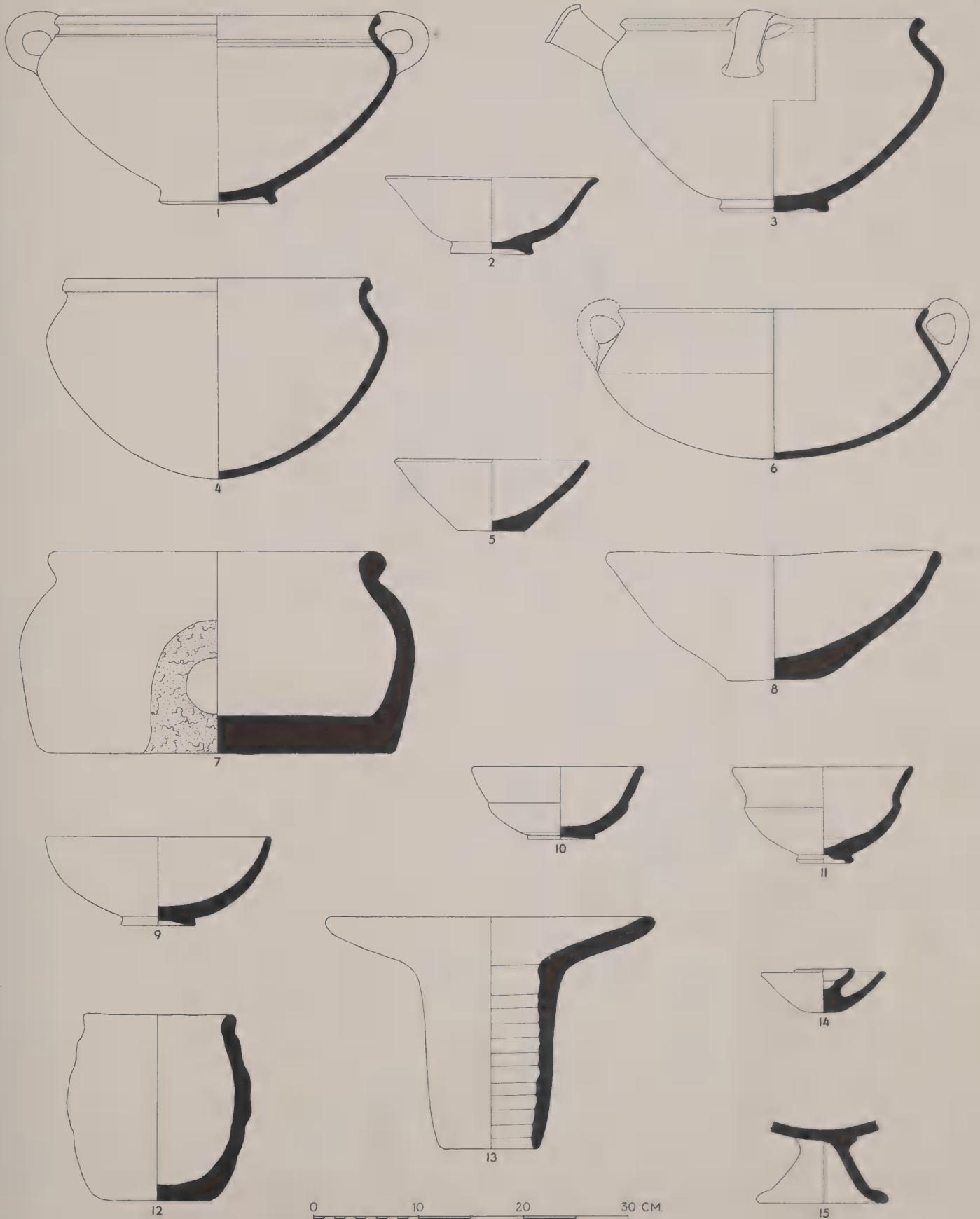

LB POTTERY FROM TOMB 3 (SEE P. 72). SCALE, 1:5

No.	Field No.	Designation	Description	Date
TOMB 18				
1	x 10	Jug	Naples yellow 3	LB I
2	x 9	Jug	Few minute mixed grits, permanent yellow 3	LB I
3	x 392	Jug	Few minute mixed grits, brown ocher 3, pellet on double handle	LB I
4	x 3	Jug	Permanent brown 3	LB I
	x 5 x 391	Jugs	Same type as No. 4	LB I
5	x 8	Jug	Brown ocher 3	LB I
6	x 393	Jug	Few minute dark grits, naples yellow 2, naples yellow 3 slip, shaved, roman sepia 2 decoration, handmade; Cypriote (see p. 153)	LB I
7	x 1	Bowl	Brown ocher 3 core, burnt umber 3 surface	LB I
8	x 2	Bowl	Predominantly light grits, permanent yellow 2	LB I
	x 7105	Bowl	Light red 1	LB I
TOMB 20				
9	x 3	Bowl	Brown ocher 3, burnished	LB I
10	x 414	Bowl	Brown ocher 3, naples yellow 3 slip, burnt umber 3 decoration	LB I
		Sherds		LB I
TOMB 21				
11	x 0442 b	Jar	Charcoal gray 3 core, brown ocher 3 surface, light red 3 slip, burnished, roman sepia 3 and burnt umber 2 decoration	LB I
12	x 444	Jar	Blue-black 3 core, burnt umber 3 surface, roman sepia 3 and burnt umber 2 decoration	LB I
13	x 0442	Jar	Fine ware, permanent brown 3, burnt umber 3 and roman sepia 2 decoration	LB I
14	x 0442 a	Jar	Fine ware, permanent brown 3, naples yellow 3 slip, burnished, burnt sienna 2 decoration	LB I
		Sherds		LB I and II
TOMB 37				
15	x 2938	Bowl	Burnt umber 3 (see p. 152)	LB I
16	x 10	Bowl	Blue-black 3 core, brown ocher 3 surface (see p. 152)	LB I
17	x 11	Cup	Many dark grits, brown ocher 3 core, permanent yellow 2 surface	LB I
18	7047	Jug	Burnt umber 3	LB I
19	02812 a	Jug	Brown ocher 3	LB I
20	2812	Jug	Burnt umber 3. See Pl. 136:1 for photograph.	LB I
21	7048	Jug	Burnt umber 3	LB I
22	2811	Jug	Permanent brown 3	LB I
23	x 02939	Jug	Fine ware, well made, well fired, charcoal gray 3 core, naples yellow 2 surface, burnished, pellet on handle	LB I
24	02812	Jug	Burnt umber 3 core, permanent yellow 2 surface	LB I
	7049	Jug	Same type as No. 24	LB I
25	x 2937	Jar	Permanent brown 3 (cf. <i>OIP XLII</i> , Pl. 11, No. 55)	MI
26	x 2939	Jar	Many dark grits, permanent brown 3 core, naples yellow 2 surface, bound with cord before firing (cf. <i>OIP XLII</i> , Pl. 11, No. 54). See Pl. 136:18 for photograph.	MI
27	x 1 a	Bowl	Permanent brown 3, indian red 3 wash inside and over rim	MI
28	x 3	Flask	Permanent yellow 3 core, naples yellow 2 surface (cf. <i>OIP XLII</i> , Pl. 36, No. 9)	MI
29	x 02939 a	Bowl	Permanent yellow 3	MI
30	x 14	Bowl	Permanent brown 3 core, naples yellow 2 surface, holes cut with knife and smoothed over with fingers (cf. <i>OIP XLII</i> , Pl. 11, No. 58 for similar holes)	MI

TOMB 18

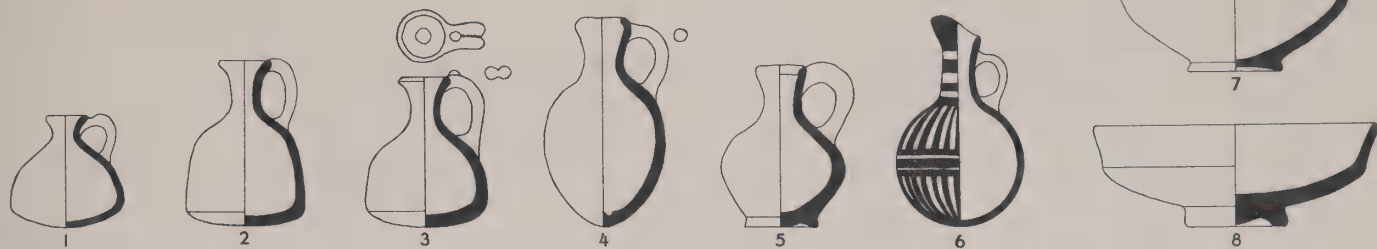

TOMB 20



TOMB 21

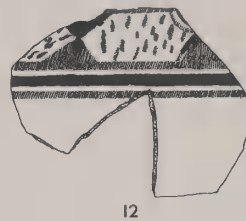

TOMB 37

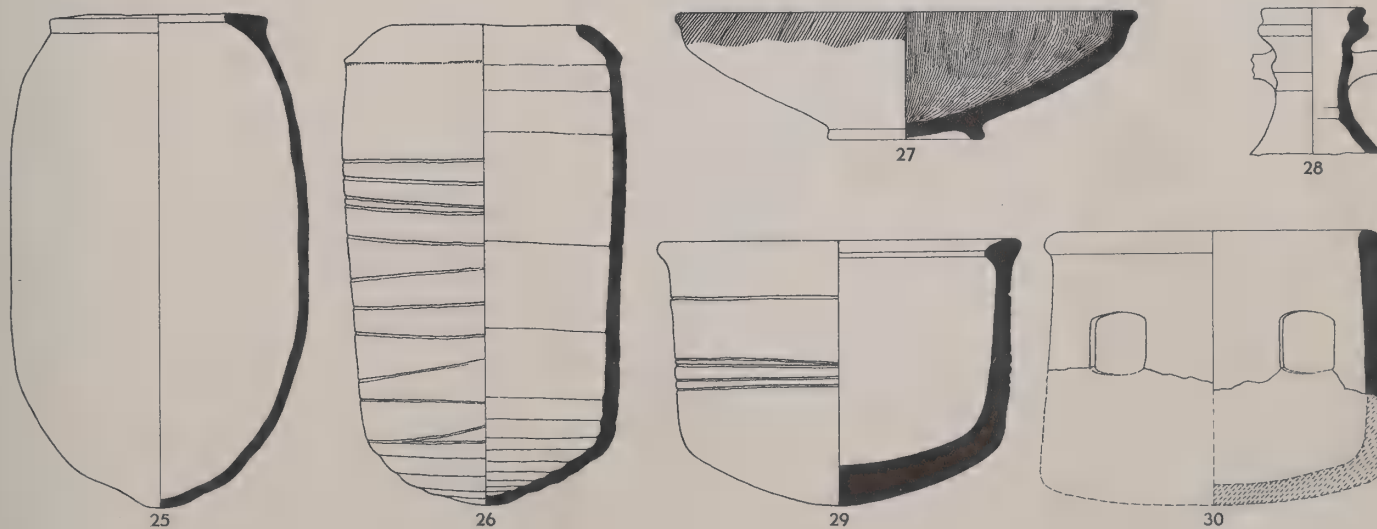
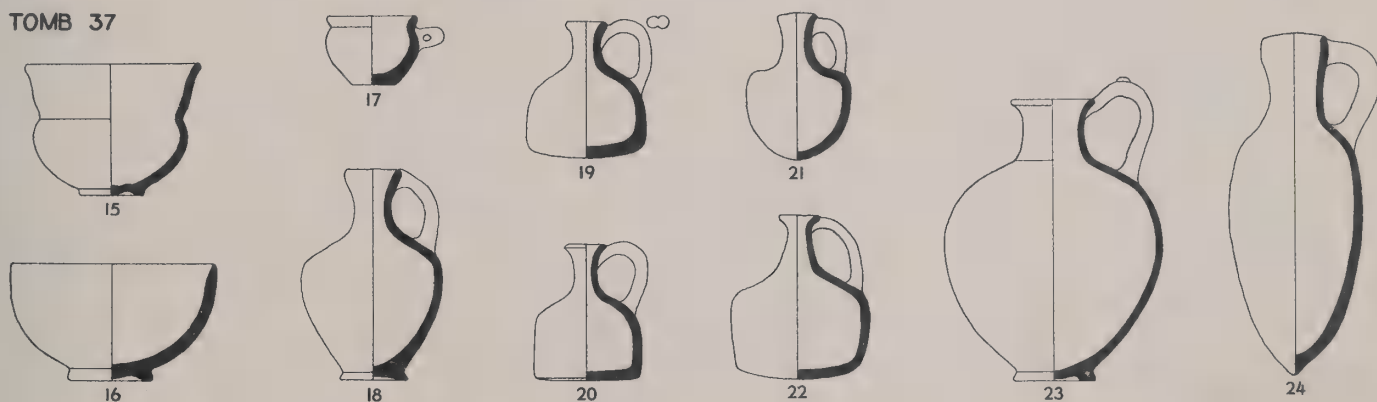

LB I AND MI POTTERY FROM TOMBS 18, 20-21, AND 37 (SEE PP. 72 AND 74-81). SCALE, 1:5

No.	Field No.	Designation	Description	Date
TOMB 37				
1	x 12	Jar-stand	Brown ocher 3 core, burnt umber 3 surface (cf. <i>OIP</i> XLII, Pl. 34, No. 10)	MI
2	x 13	Bowl	Permanent brown 3	MI
3	x 0543	Jar	Burnt umber 3 (cf. <i>OIP</i> XLII, Pl. 19, No. 98). See Pl. 136:12 for photograph.	EI II
4	x 543	Jug	Brown ocher 3, indian red 1 wash, close vertical burnishing (cf. <i>OIP</i> XLII, Pl. 5, Nos. 124-27). See Pl. 136:11 for photograph.	E-MI
5	7050	Jug	Brown ocher 3 core, indian red 3 surface, burnished. See Pl. 136:10 for photograph.	EI II
6	x 1916	Jug	Brown ocher 3, indian red 3 decoration, strainer spout with 11 holes. See Pl. 136:13 for photograph.	EI
TOMB 37 A				
7	x 2817	Jug	Permanent yellow 3	LB I
	x 2	Jug	Same type as No. 7	LB I
8	x 2819	Jug	Brown ocher 3. See Pl. 137:9 for photograph.	LB I
	x 7056-60	Jugs	Same type as No. 8	LB I
9	x 2818	Bowl	Permanent yellow 3 (see p. 151). See Pl. 137:10 for photograph.	LB I
10	x 6	Jug	Well made, charcoal gray 3 core, burnt umber 3 surface	LB I
	x 7061	Jug	Same type as No. 10	LB I
11	x 8	Bowl	Charcoal gray 3 core, burnt umber 3 surface	LB II
12	x 7	Bowl	Permanent brown 3, indian red 3 slip outside and over rim	LB I
		Sherds		MB I
TOMB 37 E				
13	x 2942	Jar	Permanent brown 3 core, indian red 3 surface, 7 handles, thumb mark on one handle (cf. <i>OIP</i> XLII, Pls. 18, No. 89, and 21, No. 125)	E-MI
14	x 02942	Jar	Blue-black 3 core, brown ocher 3 surface	EI
15	x 2944	Cooking bowl	Many dark grits, brown ocher 3 core, burnt sienna 3 surface (cf. <i>OIP</i> XLII, Pl. 40, No. 13)	E-MI

TOMB 37

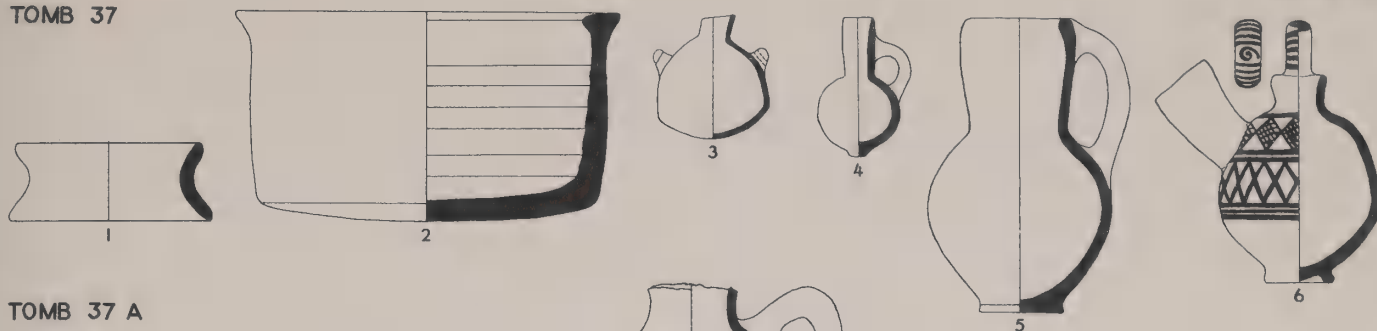

TOMB 37 A

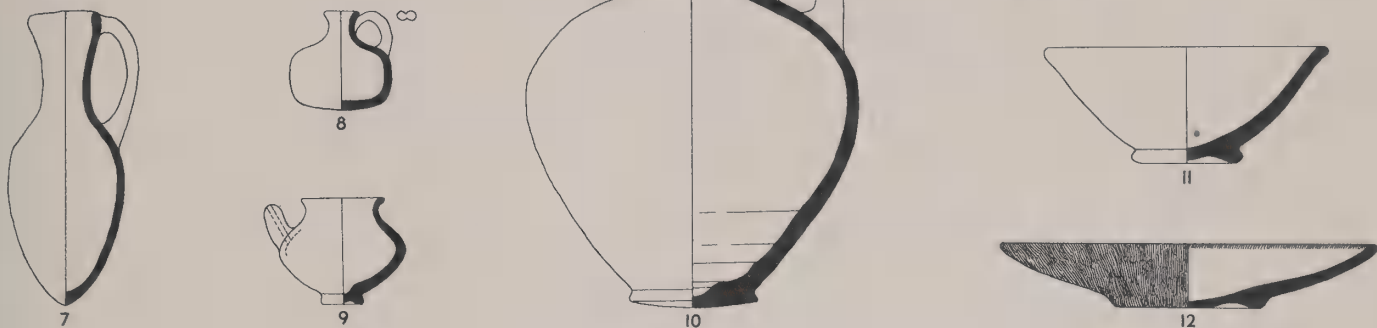

TOMB 37 E

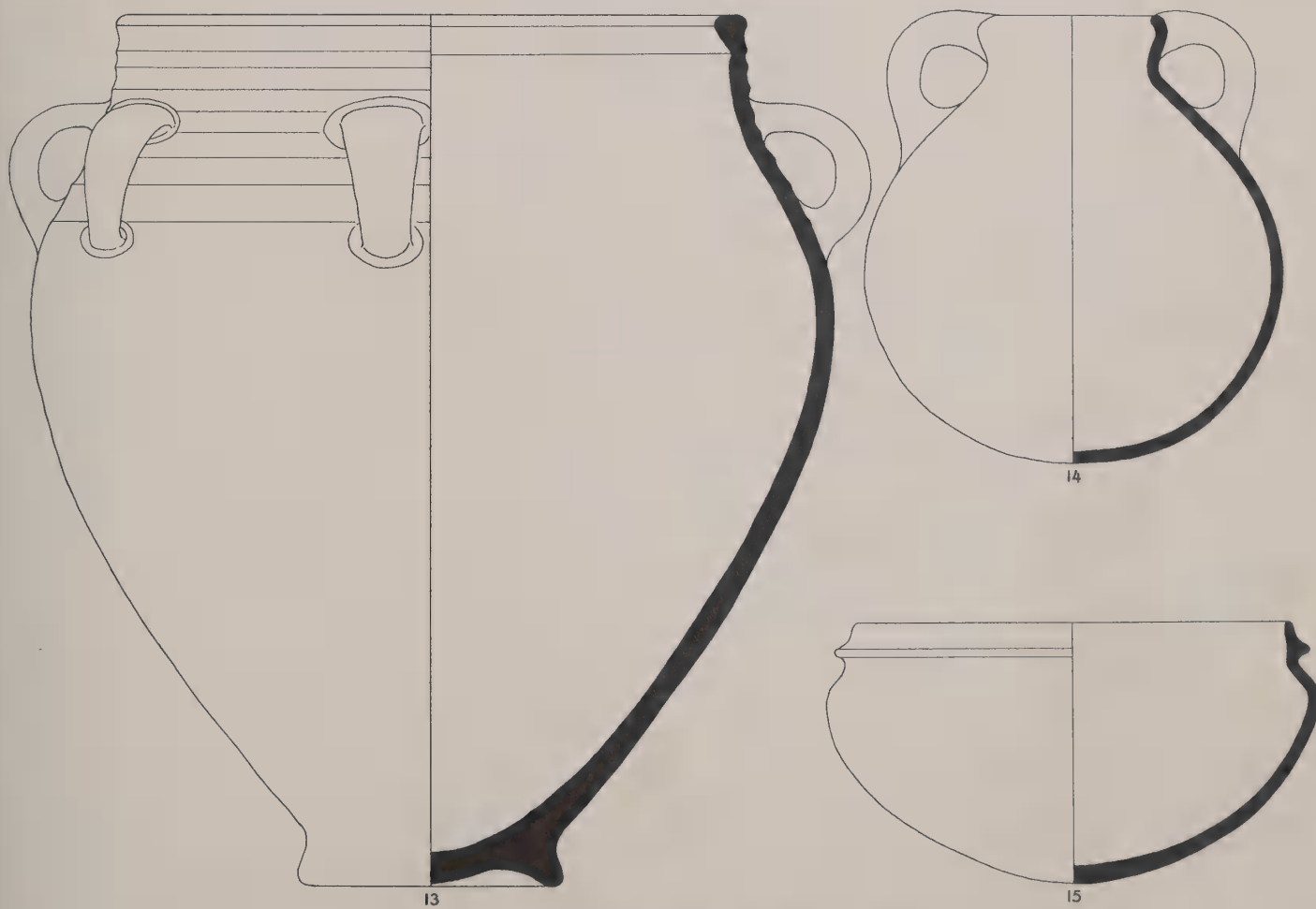

LB AND IRON AGE POTTERY FROM TOMB 37 (SEE PP. 74-81). SCALE, 1:5

No.	Field No.	Designation	Description	Date
TOMB 37 E				
1	x 2943	Jar	Permanent brown 3, pottery mark on one handle (cf. <i>OIP</i> XLII, Pl. 21, Nos. 122-23)	EI II
2	x 8	Jug	Many mixed grits, brown ocher 2 core, burnt sienna 3 surface (cf. <i>OIP</i> XLII, Pl. 5, Nos. 118-19)	E-MI
	x 9	Jug	Same type as No. 2	E-MI
3	x 02941	Jug	Blue-black 3 core, burnt umber 3 surface (cf. <i>OIP</i> XLII, Pl. 5, Nos. 118-19)	E-MI
	x 6-7	Jugs	Same type as No. 3	E-MI
4	x 2941	Jug	Blue-black 3 core, naples yellow 3 surface	EI II
5	x 13	Jar	Blue-black 3 core, brown ocher 3 surface, indian red 2 wash, burnished	EI II
		Sherds		MI
TOMB 37 F				
6	x 2945	Jar	Permanent brown 3, naples yellow 3 slip (cf. <i>OIP</i> XLII, Pl. 11, No. 55)	MI
	x 4	Jar	Same type as Pl. 171:20	MI
		Sherds		MI
TOMB 37 K 4				
7	02821	Bowl	Burnt umber 3. See Pl. 138:10 for photograph.	LB I
8	2820	Jug	Brown ocher 3. See Pl. 138:11 for photograph.	LB I
9	2821	Jug	Permanent brown 3. See Pl. 138:12 for photograph.	LB I
	x 16	Jug	Same type as Pl. 38:19	LB I
	x 30	Jar	Same type as Pl. 41:26	LB I
TOMB 38				
10	x 3398	Bowl	Brown ocher 3	LB I
	x 3362	Bowl	Same type as No. 10	LB I
11	x 3363	Bowl	Brown ocher 3, indian red 3 decoration on rim	LB I
	x 88	Bowls	Same type as No. 11	LB I
	x 90			
	x 3405-6			
	x 03404-5			
12	x 3404	Bowl	Blue-black 3 core, brown ocher 3 surface, indian red 3 and roman sepia 3 decoration	LB I
13	x 3354	Bowl	Poorly made, brown ocher 3	LB I
14	x 3353	Bowl	Poorly made, brown ocher 3	LB I
	x 3414-19	Bowls	Same type as No. 14	LB I
	x 3444-46			
	x 03414-16			
	x 03419			
15	x 3361	Bowl	Brown ocher 3	LB I
	x 3364	Bowl	Same type as No. 15	LB I
16	x 3366	Bowl	Brown ocher 3, indian red 3 decoration (see p. 151). See Pl. 139:10 for photograph.	LB I
17	x 3396	Bowl	Poorly made, brown ocher 3 (see p. 152)	LB I
18	x 03356	Bowl	Many light grits, poorly made, brown ocher 3 (see p. 152)	LB I
	x 3357-60	Bowls	Same type as No. 18	LB I
	x 3397			
19	x 3409	Cooking bowl	Many mixed grits, burnt umber 3 (see p. 152)	LB I
20	x 3351	Lamp	Brown ocher 3	LB I
	x 3355-56	Lamps	Same type as No. 20	LB I
	x 3400-3403			
	x 3447-52			

TOMB 37 E

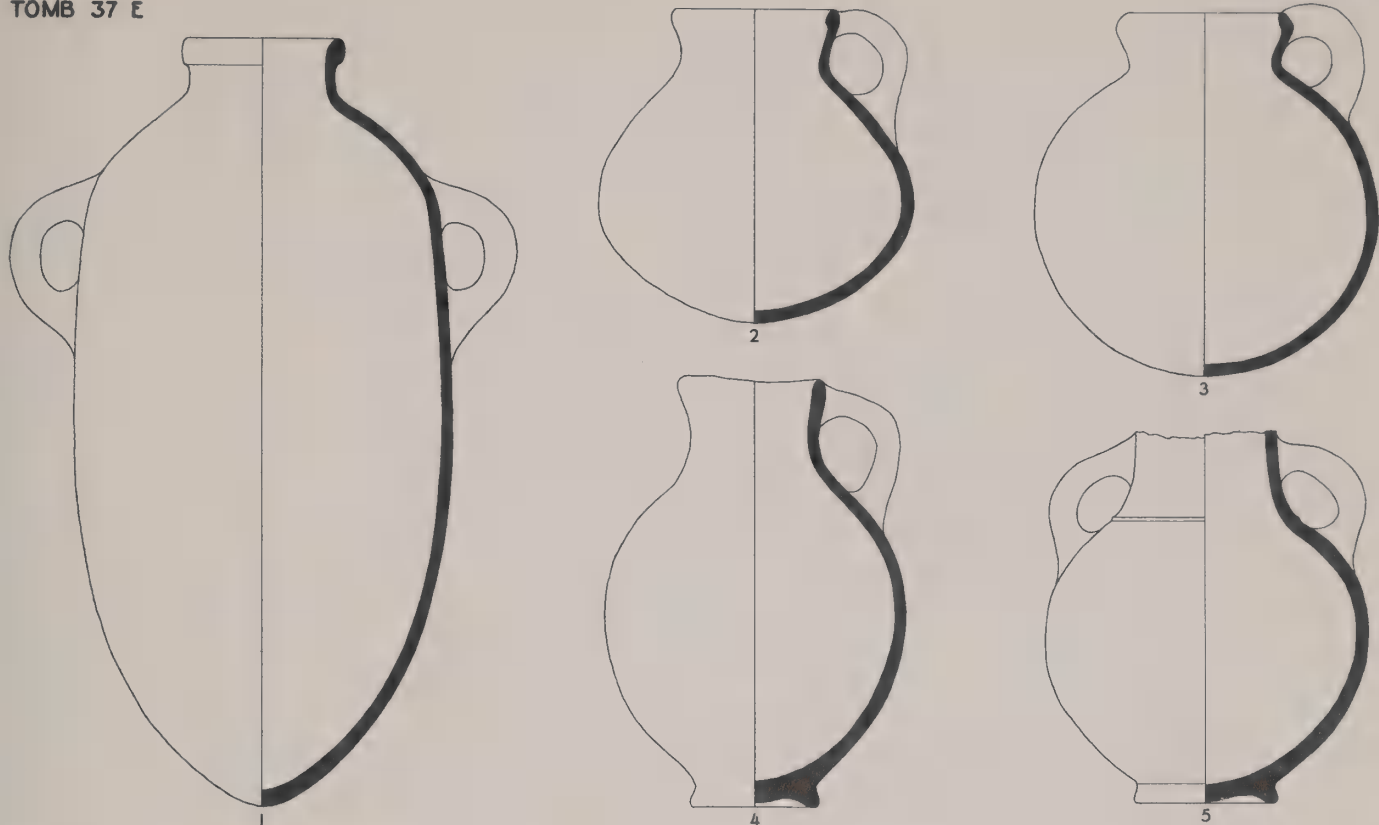

TOMB 37 F

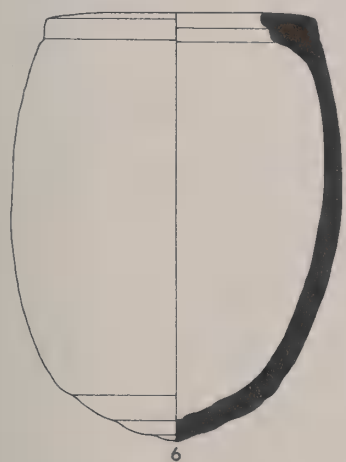

TOMB 37 K 4

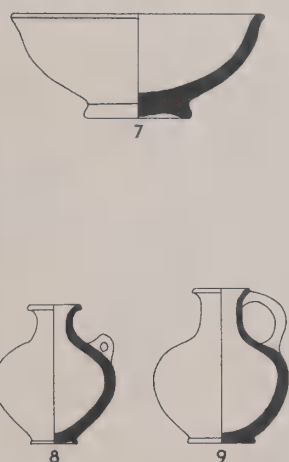

TOMB 38

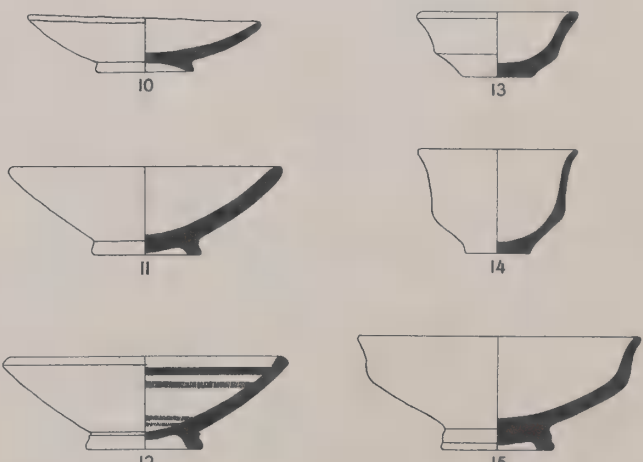

TOMB 38

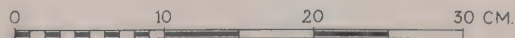

No.	Field No.	Designation	Description
TOMB 38			
1	x 03449	Jug	Many light grits, permanent brown 3 core, brown ocher 3 surface, indian red 3 decoration
	x 3433-35 x 3437-38 x 3441-42 x 03434 x 03437-38	Jugs	Same type as No. 1; LB I
2	x 3367	Jug	Brown ocher 3, naples yellow 2 slip, burnt sienna 3 and roman sepia 2 decoration. See Pl. 139:18 for photograph.
	x 3373-83 x 3429 x 3431-32 x 3453-54 x 03376 x 03380	Jugs	Same type as No. 2; LB I
3	x 3370	Jug	Brown ocher 3, indian red 3 decoration
4	x 3371	Jug	Many large light grits, brown ocher 3, indian red 2 decoration
5	x 3372	Jug	Many large light grits, brown ocher 3, indian red 3 decoration
6	x 3395	Jug	Brown ocher 3, indian red 3 decoration
	x 3369	Jug	Same type as No. 6; LB I
7	x 3421	Jug	Many light grits, brown ocher 1, indian red 3 decoration
8	x 3425	Jug	Brown ocher 3, indian red 3 decoration
	x 3420	Jug	Same type as No. 8; LB I
9	x 3426	Jug	Many light grits, brown ocher 3, roman sepia 3 and indian red 2 decoration. See Pl. 139:23 for photograph.
	x 3423 x 3427-28	Jugs	Same type as No. 9; LB I
10	x 3430	Jug	Poorly made, brown ocher 3, indian red 3 decoration
11	x 3443	Jug	Permanent brown 3, naples yellow 3 slip, indian red 3 decoration. See Pl. 139:15 for photograph.
12	x 3439	Jug	Permanent brown 3 core, brown ocher 3 surface, burnt umber 2 decoration. See Pl. 139:22 for photograph.
13	x 3368	Jug	Some light grits, charcoal gray 3 core, brown ocher 3 surface. See Pl. 139:16 for photograph.
TOMB 38 B			
14	7001	Jug	Brown ocher 3, indian red 3 decoration. See Pl. 140:12 for photograph.
15	x 3468	Jug	Many mixed grits, burnt umber 3, indian red 2 decoration. See Pl. 140:13 for photograph.
16	7002	Jug	Brown ocher 3
17	x 3467	Jar	Well made, burnt umber 3, naples yellow 3 slip, horizontal burnishing, sepia 3 decoration. See Pl. 140:11 for photograph.
18	x 3455	Bowl	Brown ocher 3. See Pl. 140:5 for photograph.
19	x 3456	Bowl	Brown ocher 3, indian red 3 decoration
	7000	Bowl	Some type as No. 19; LB I
20	x 3457	Bowl	Many large light grits, poorly made, brown ocher 3
	x 3459-60	Bowls	Same type as No. 20; LB I
TOMB 75			
21	P 179	Jug	Many light grits, well made, well fired, brown ocher 3, close vertical burnishing, indian red 1 and roman sepia 2 decoration. See Pl. 140:23 for photograph.
22	P 182	Jug	Some light grits, well fired, brown ocher 3 core, naples yellow 2 to 3 surface, close vertical burnishing. See Pl. 140:22 for photograph.
23	P 180	Jug	Fine ware, few minute mixed grits, chiefly permanent brown 3 core, black lead 2 surface, close horizontal burnishing. See Pl. 140:21 for photograph.
24	P 181	Jug	Same as No. 23 except for black lead 2 core
TOMB 77			
25	P 234	Jug	Some light grits, well fired, permanent brown 3. See Pl. 140:26 for photograph.
26	P 235	Jar	Many light grits, permanent brown 3 core, burnt umber 3 surface. See Pl. 140:33 for photograph.
27	P 232	Jug	Intact, fine ware, well made, well fired, naples yellow 3 slip, indian red 1 and sepia 2 decoration, handmade; Cypriote (see p. 153). See Pl. 140:24 for photograph.
28	P 233	Jug	Intact, some light grits, well fired, naples yellow 2 surface, sepia 1 decoration, handmade; Cypriote (see p. 153). See Pl. 140:25 for photograph.
29	5536	Jug	Fine ware, some dark grits, permanent brown 3
30	P 222	Jug	Some light grits, burnt umber 3
31	5533	Jug	Fine ware, some light grits, burnt umber 3 core, brown madder 3 surface
32	P 241	Jug	Some light grits, well fired, burnt umber 3 core, brown madder 3 surface

TOMB 38

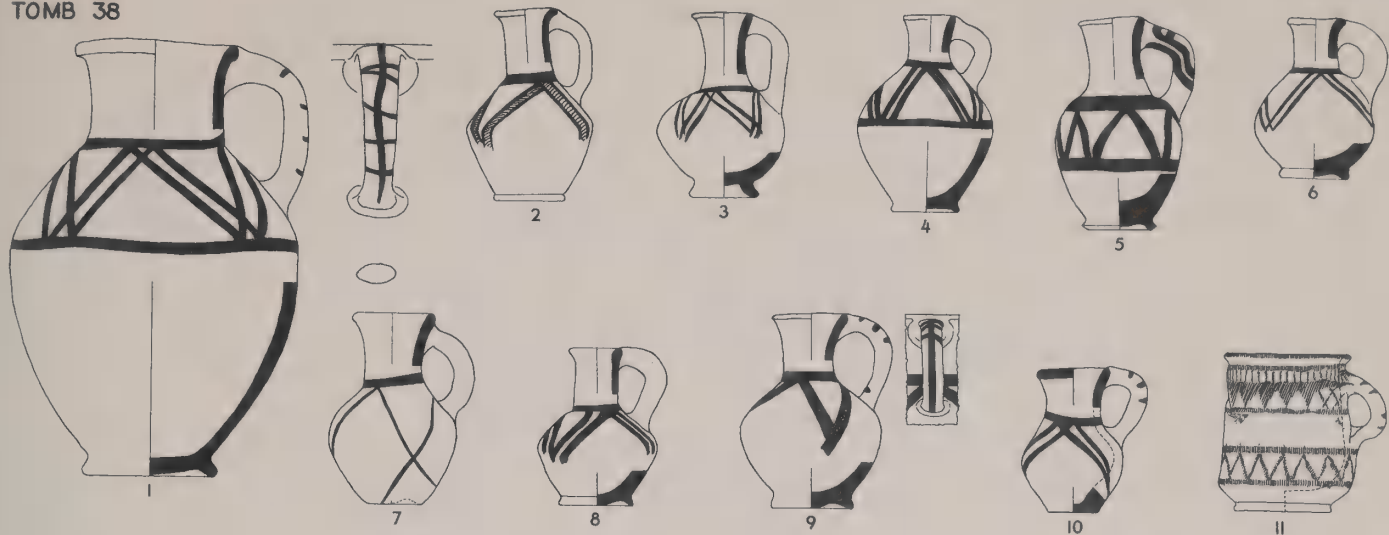

TOMB 38 B

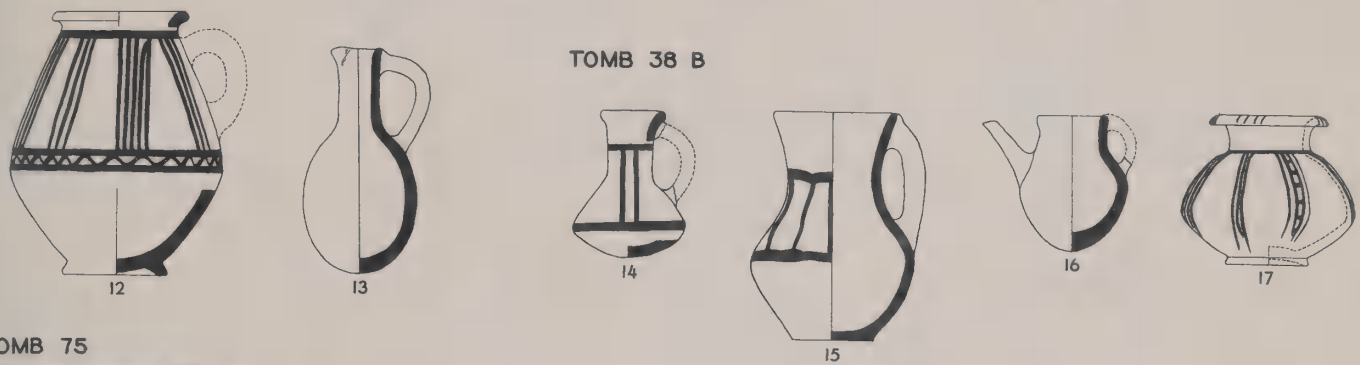

TOMB 75

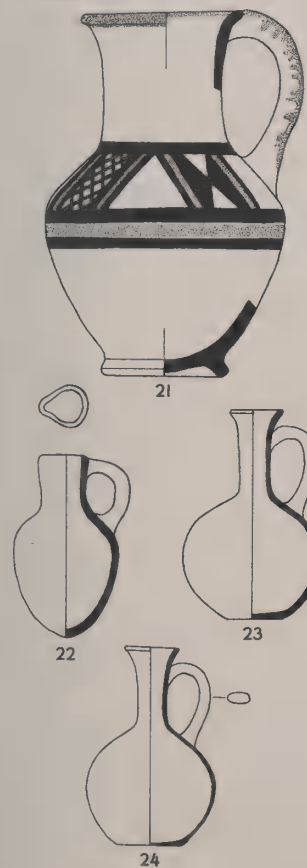

TOMB 77

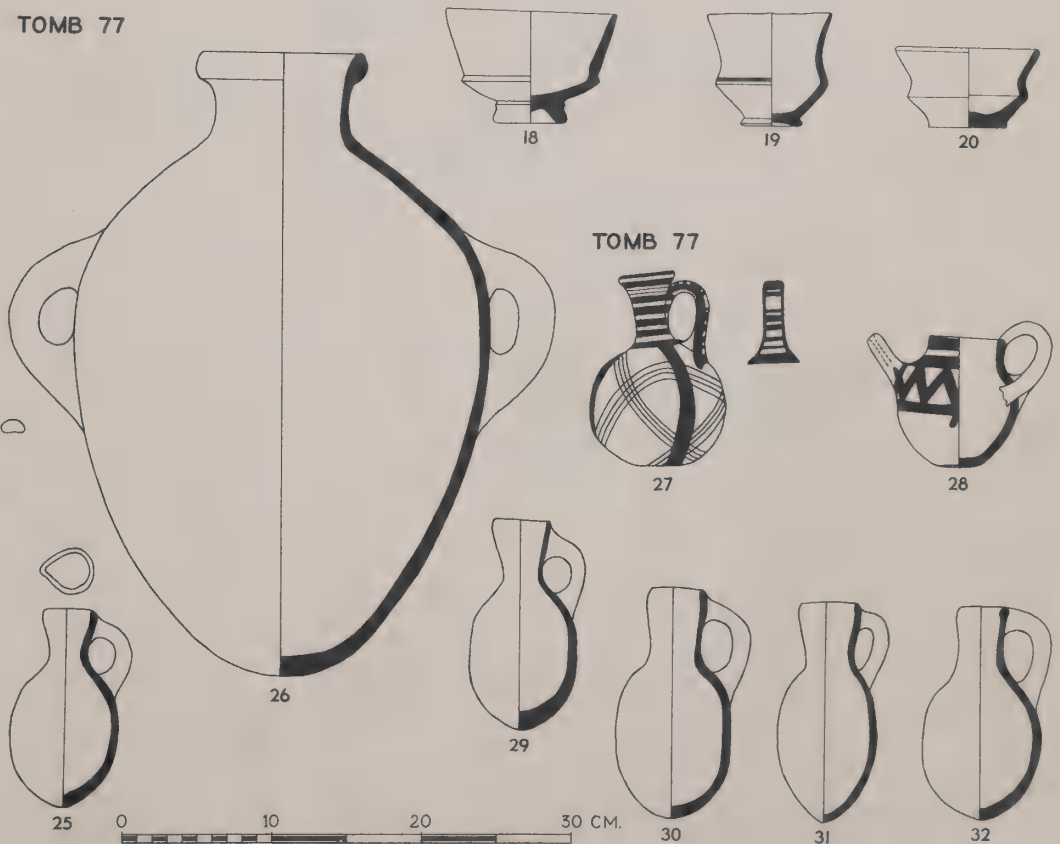

LB I POTTERY FROM TOMBS 38, 75, AND 77 (SEE P. 82). SCALE, 1:5

No.	Field No.	Designation	Description	Date*
TOMB 77				
1	P 238	Jug	Some light grits, permanent brown 3, traces of light red 3 decoration	LB I
2	P 239	Jug	Some large light grits, well fired, burnt umber 3, light red 3 decoration. See Pl. 140:27 for photograph.	LB I
3	P 240	Jug	Intact, few large light grits, poorly made, well fired, permanent brown 3, indian red 3 decoration. See Pl. 140:28 for photograph.	LB I
4	P 237	Jug	Intact, few mixed grits, well fired, burnt umber 3, light red 3 decoration. See Pl. 140:29 for photograph.	LB I
5	5534	Jug	Same as No. 3 except for no decoration	LB I
6	P 223	Jug	Same as No. 4 except for roman sepia 2 core	LB I
7	P 236	Jug	Some large mixed grits, well fired, permanent brown 3 core, burnt umber 3 surface, near indian red 3 decoration. See Pl. 140:30 for photograph.	LB I
8	P 224	Jug	Some light grits, well made, burnt umber 3, indian red 3 decoration	LB I
9	5535	Bowl	Some light grits, burnt umber 2 core, burnt umber 3 surface	LB I
10	P 242	Bowl	Same as No. 9	LB I
11	P 231	Bowl	Intact; same as No. 9. See Pl. 140:31 for photograph.	LB I
12	P 229	Milk bowl	Intact, fine ware, some light grits, well fired, burnt umber 1, light red 1 wash, handmade; Cypriote (see p. 153)	LB I
13	P 230	Milk bowl	Same as No. 12 except for brown ocher 1 core and surface	LB I
14	P 228	Milk bowl	Intact, fine ware, few light grits, well fired, brown ocher 1, indian red 2 wash, burnished, handmade; Cypriote (see p. 154). See Pl. 140:32 for photograph.	LB I
	P 429 3527-29 3602 5538	Vessels	All very fragmentary, and some definitely intrusive	
TOMB 78				
15	P 245	Jug	Intact, well made, brown ocher 3. See Pl. 141:3 for photograph.	LB I
16	3532	Jug	Many mixed grits, permanent brown 3 core, burnt umber 3 surface, pellet on double handle	LB I
17	P 243	Jug	Same as No. 15 except for blue-black 3 core and indian red 3 decoration. See Pl. 141:2 for photograph.	LB I
18	P 246	Jar	Same as No. 15 except for more grits and indian red 3 and blue-black 3 decoration. See Pl. 141:1 for photograph.	LB I
19	P 247	Lamp	Same as No. 15	LB I
20	P 244	Bowl	Well fired, blue-black 3 core, naples yellow 2 surface	LB I
21	4086	Bowl	Same as No. 15 except that it is fairly well made and has blue-black 3 core	LB I
22	3531	Bowl	D. .31, many minute dark grits, lightly fired, brown ocher 3 core, naples yellow 1 inside surface, light red 1 slip outside, handmade; intrusive	Stages IV-VII. Col. 13
23	P 248	Bowl	Many minute mixed grits, well fired, burnt umber 3, permanent yellow 3 slip outside (cf. <i>OIP</i> XLII, Pl. 23, Nos. 13-15). See Pl. 141:4 for photograph.	MI
TOMB 219				
24	3559	Bowl	Burnt umber 2. See Pl. 141:5 for photograph.	LB I
25	P 296	Bowl	Blue-black 3 core, naples yellow 2 surface. See Pl. 141:6 for photograph.	LB I
26	3558	Bowl	Same as No. 25 except for burnt umber 3 surface. See Pl. 141:7 for photograph.	LB I
27	4310	Jug	Many large mixed grits, blue-black 3 core, brown ocher 2 surface	LB I
28	3557	Jar	Many mixed grits, lightly fired, naples yellow 3, handmade. See Pl. 141:10 for photograph.	Stages I-IV
29	P 297	Jug	Many large mixed grits, lightly fired, brown ocher 3. See Pl. 141:9 for photograph.	LB II
30	4309	Jug	Fine ware, few minute mixed grits, chiefly roman sepia 3 core, brown ocher 2 surface (cf. <i>OIP</i> XLII, Pl. 2, No. 67). See Pl. 141:11 for photograph.	MI
31	P 300	Jug	Fine ware, few minute mixed grits, chiefly roman sepia 3 core, brown ocher 2 surface. See Pl. 141:12 for photograph.	Hellenistic

\* "Stages" do not date a given piece but indicate the duration of its type. See *SAOC* No. 10, pp. 52-65 and chart.

TOMB 77

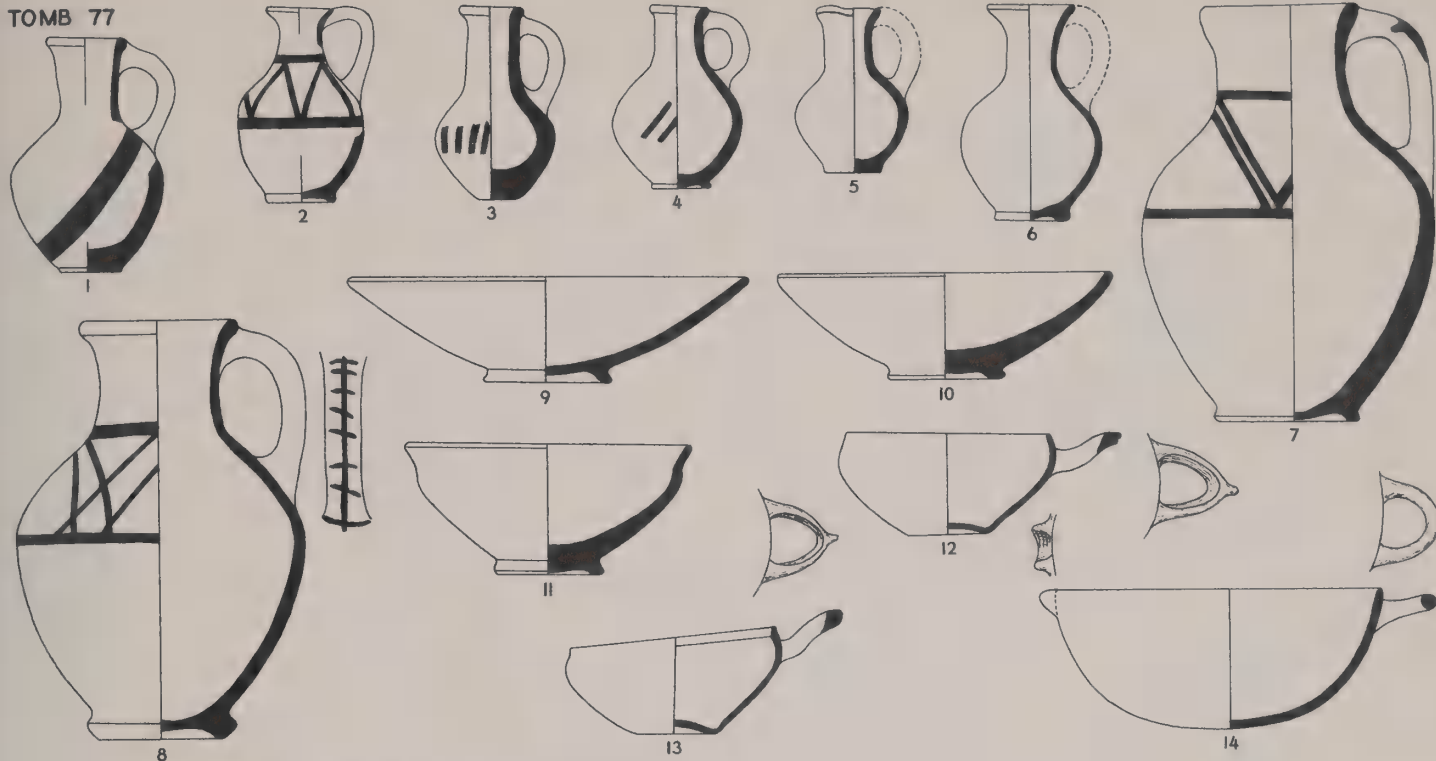

TOMB 78

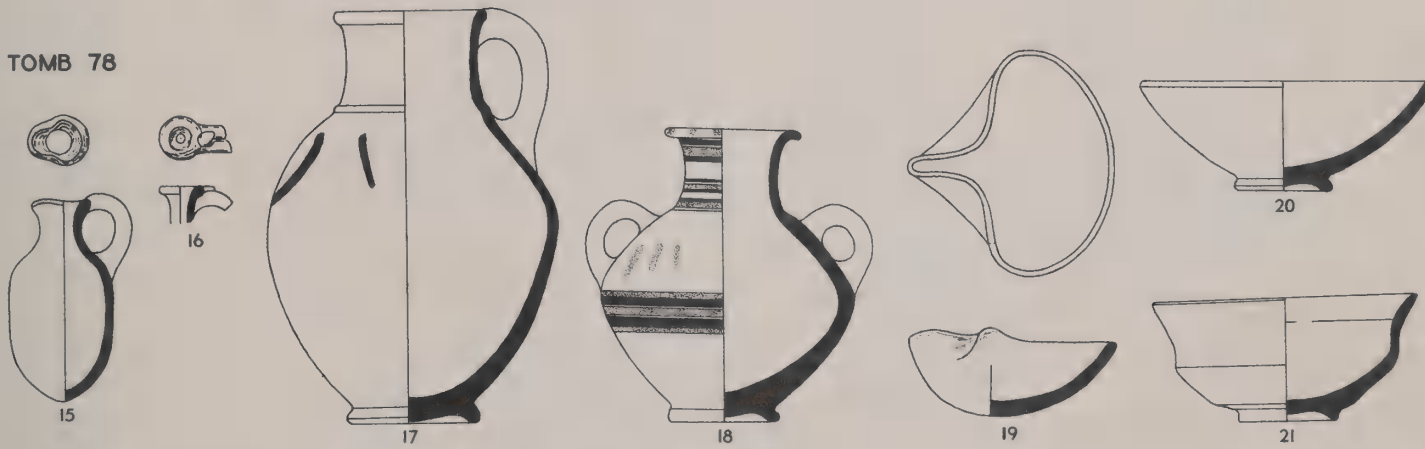

TOMB 219

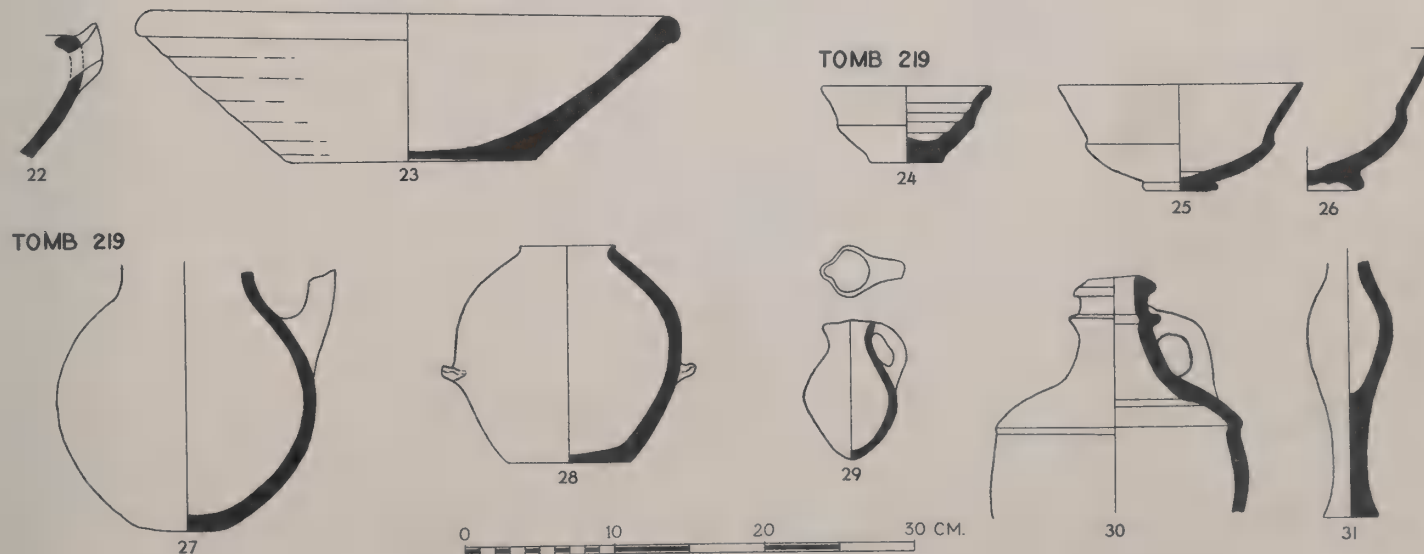

POTTERY FROM TOMBS 77-78 AND 219 (SEE PP. 82-85 AND 87). SCALE, 1:5

No.	Field No.	Designation	Description
TOMB 219			
1	3556	Bowl	Sepia 3 core, permanent brown 3 outside surface, light red 2 wash inside and over rim (cf. <i>OIP XLII</i> , Pl. 24, No. 46). See Pl. 141:8 for photograph.
2	4311	Chalice	Naples yellow 3 (cf. <i>OIP XLII</i> , Pl. 33, No. 5)
TOMB 855			
3	P 2741	Bowl	Many large light grits, brown ocher 2
4	P 2726	Bowl	Same as No. 3 except for lighter surface
5	P 2731	Jug	Fine ware, few minute dark grits, naples yellow 2, shaved, roman sepia 2 decoration, handmade; Cypriote (see p. 153). See Pl. 141:26 for photograph.
6	P 2719	Bilbil	Complete, fine ware, few minute light grits, well fired, blue-black 3 to burnt umber 2 slip, handmade; Cypriote (see p. 154). See Pl. 141:27 for photograph.
7	P 2715	Bilbil	Same as No. 6 except for sepia 3 core
8	P 2714	Bilbil	Same as No. 6 except for blue-black 3 core, naples yellow 3 decoration on body and neck, and incised decoration on handle
9	P 2716	Jug	Intact; same as No. 3 except for indian red 3 decoration. See Pl. 141:13 for photograph.
10	P 2746	Jug	Many large light grits, well fired, permanent brown 3 core, naples yellow 3 surface, decoration faded to brown ocher 2. See Pl. 141:14 for photograph.
	P 2833	Jug	Same type as No. 10; LB I
11	P 2752	Jug	Many large mixed grits, blue-black 2 core, brown ocher 2 surface, indian red 3 and sepia 3 decoration
12	P 2723	Cooking bowl	Coarse ware, many mixed grits, blue-black 2 core, burnt umber 1 surface
13	P 2771	Flask	Same as No. 6 except for permanent brown 2 core, handmade; Cypriote base-ring ware (see p. 155)
14	P 2751	Bowl	Many mixed grits, brown ocher 2, spaced horizontal burnishing, indian red 3 decoration
15	P 2750	Bowl	Same as No. 14. See Pl. 141:15 for photograph
16	P 2743	Bowl	Same as No. 17 except for brown ocher 2 core and surface and spaced ring burnishing inside; badly warped. See Pl. 141:16 for photograph.
17	P 2722	Bowl	Many large light grits, well fired, burnt umber 3
18	P 2748	Bowl	Many mixed grits, blue-black 3 core, brown ocher 2 surface
19	P 2725	Bowl	Same as No. 18 except for chiefly permanent brown 3 core. See Pl. 141:17 for photograph.
20	P 2740	Bowl	Intact; same as No. 18 but core is not visible. See Pl. 141:18 for photograph.
21	P 2742	Bowl	Same as No. 18 except for permanent brown 3 core
22	P 2749	Bowl	Fine ware, some minute mixed grits, well made, well fired, naples yellow 2 core, naples yellow 1 surface, close ring burnishing. See Pl. 141:19 for photograph.
23	P 2732	Jug	Intact, few mixed grits, well made, chiefly brown ocher 2 surface, spaced vertical burnishing on body and irregular burnishing on base. See Pl. 141:20 for photograph.
24	P 2718	Jug	Few minute light grits, well made, well fired, naples yellow 3, close horizontal burnishing on body and straight-line burnishing on base, faint traces of warm sepia 3 decoration: 3 horizontal bands around body, one around base of neck, 3 oblique lines on shoulder. See Pl. 141:21 for photograph.
25	P 2727	Jug	Many light grits, well fired, black lead 3 core, naples yellow 2 surface, spaced vertical burnishing on body and irregular burnishing on base, double handle
26	P 2744	Jug	Some light grits, permanent brown 3 core, brown ocher 2 surface, spaced horizontal burnishing
27	P 2734	Jug	Same as No. 26 except for more grits and double handle
28	P 2724	Jug	Well fired, brown ocher 3, spaced horizontal burnishing, indian red 3 and sepia 3 decoration. See Pl. 141:22 for photograph.
29	P 2717	Jug	Intact, many mixed grits, chiefly brown ocher 3 surface, spaced vertical burnishing. See Pl. 141:23 for photograph.
30	P 2721	Jug	Intact; same as No. 29. See Pl. 141:24 for photograph.
31	P 2747	Jug	Few minute mixed grits, well made, well fired, burnt umber 3, spaced vertical burnishing; found in P 2745 (see Fig. 102)
32	P 2733	Jug	Some large grits, well made, well fired, brown ocher 2, spaced vertical burnishing. See Pl. 141:25 for photograph.

TOMB 219

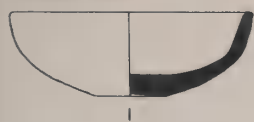

TOMB 855

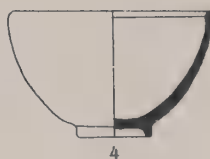
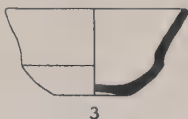

TOMB 855

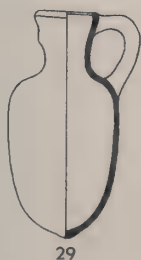
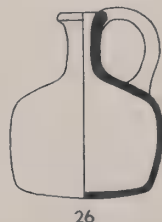
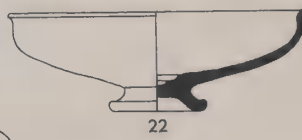
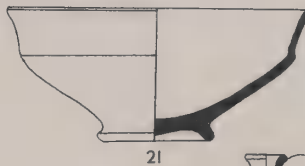
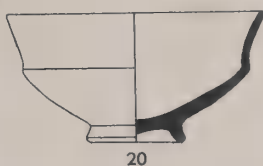
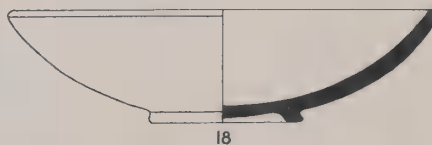
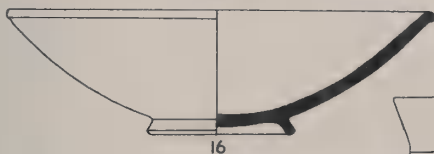
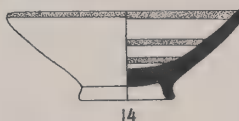
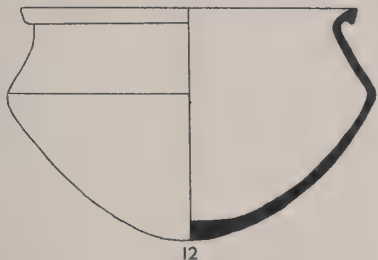
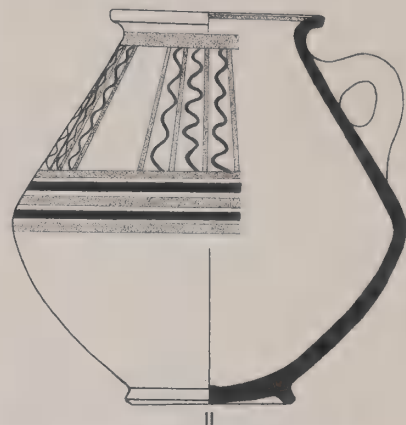
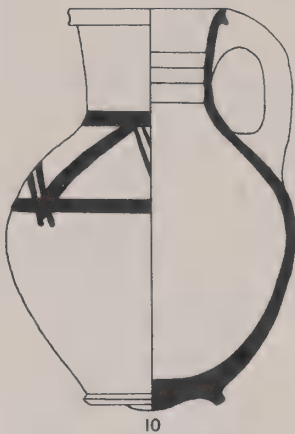
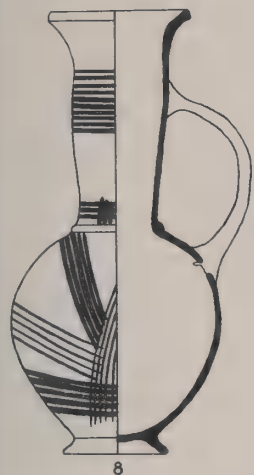

MI POTTERY FROM TOMB 219 AND LB I POTTERY FROM TOMB 855 (SEE P. 87). SCALE, 1:5

No.	Field No.	Designation	Description
TOMB 855			
1	P 2728	Jug	Many large light grits, burnt umber 3 and black lead 3 core, burnt umber 2 surface
2	P 2730	Jug	Blue-black 2 core, burnt umber 2 surface
3	P 2735	Jar	Many mixed grits, brown ocher 2, worn permanent yellow 3 slip, indian red 3 and faded roman sepia 3 decoration; rim restored from No. 2 on Pl. 53
4	P 2739	Jar	Many light grits, well fired, chiefly permanent brown 3 core, naples yellow 3 surface, incised decoration
	P 2745	Jar	Same type as No. 4 (see Fig. 102); LB I
	P 2834	Jar	Same type as No. 4; LB I
5	P 2720	Lamp	Many mixed grits, blue-black 3 core, brown ocher 2 surface, lip blackened by fire
6	P 2737	Lamp	Poorly made, brown ocher 2, lip blackened by fire. See Pl. 141:28 for photograph.
	P 2738	Jar	EB (see Fig. 102); intrusive
TOMB 856			
7	P 2754	Lamp	Same as No. 5 except for brown ocher 2 core. See Pl. 142:3 for photograph.
8	P 2797	Bowl	D. .30; same as No. 5 except for fewer grits
9	P 2799	Bowl	Blue-black 3 core, brown ocher 2 surface
10	P 2798	Bowl	Same as No. 9 except for spaced ring burnishing
11	P 2801	Bowl	Many large light grits, well made, naples yellow 2
12	P 2753	Jug	Fine ware, some minute mixed grits, well made, well fired, brown ocher 2 core, brown ocher 2 to naples yellow 3 surface, close vertical burnishing on body, close ring burnishing on base
13	P 2713	Jug	Some light grits, well fired, permanent brown 3 core, naples yellow 3 surface. See Pl. 142:4 for photograph.
14	P 2800	Jug	Blue-black 3 core, burnt umber 2 surface
TOMB 876			
15	P 3364	Jug	Many mixed grits, well made, well fired, blue-black 3 core, naples yellow 2 to brown ocher 2 surface. See Pl. 142:7 for photograph.

TOMB 855

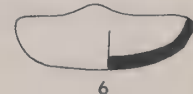
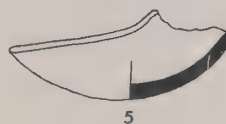
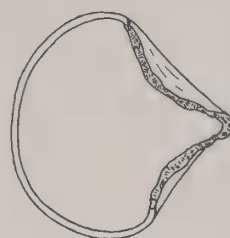
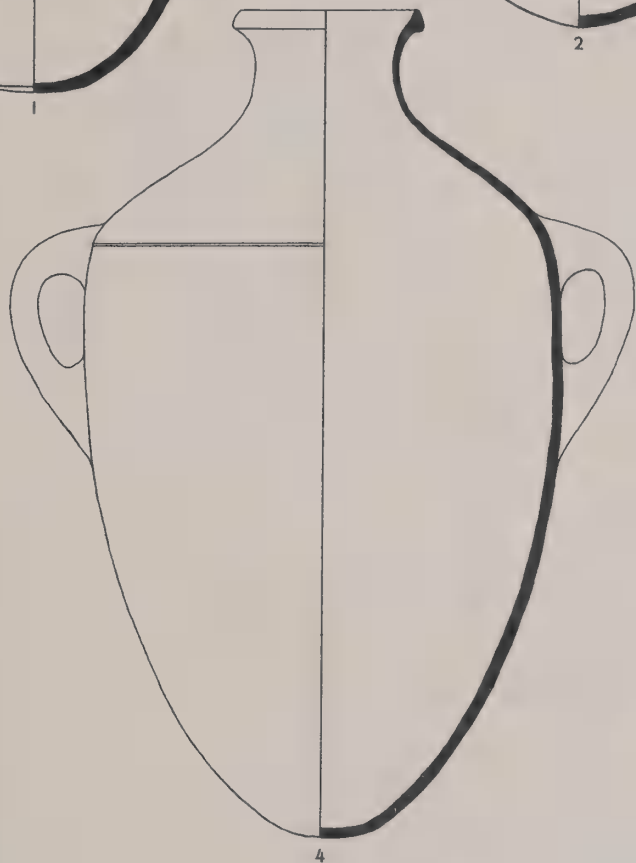
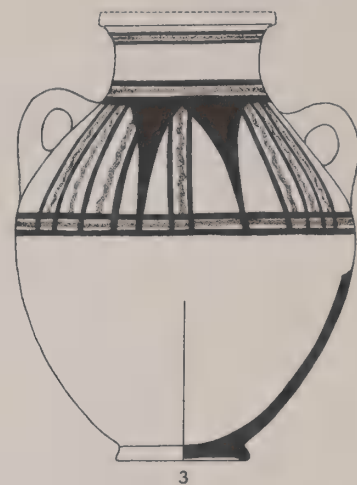
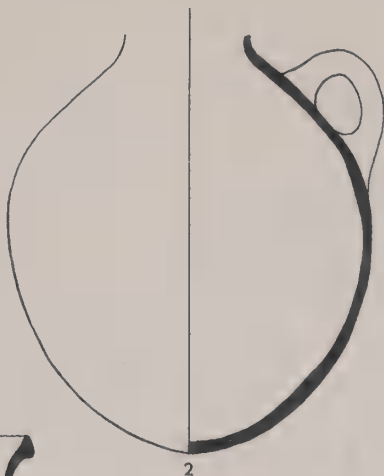
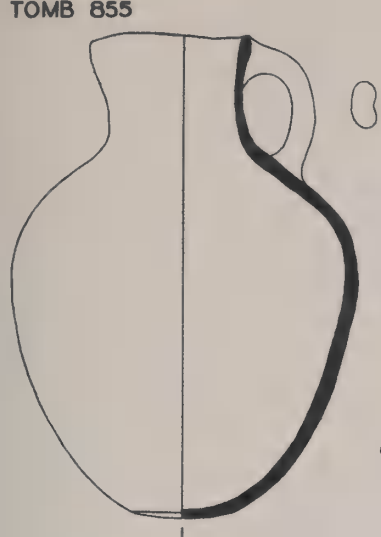

TOMB 856

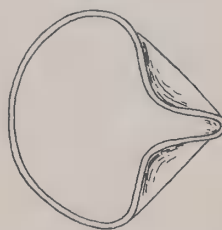

TOMB 856

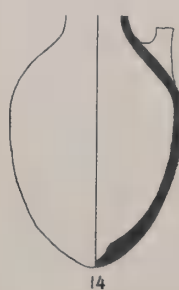
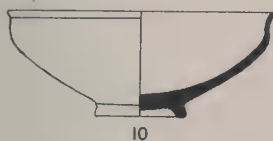

TOMB 876

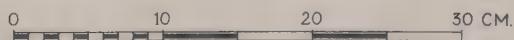
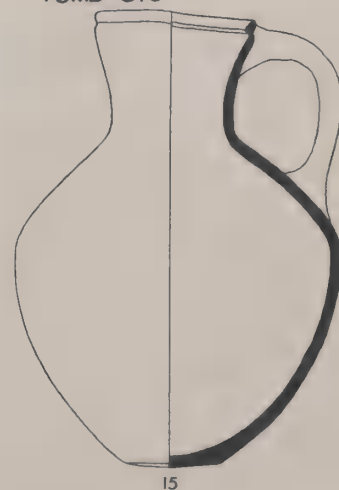

LB I POTTERY FROM TOMBS 855-56 AND 876 (SEE P. 87). SCALE, 1:5

No.	Field No.	Designation	Description
TOMB 921			
1	P 3366	Jug	Many minute mixed grits, brown ocher 2
2	P 3887	Jug	Blue-black 3 core, brown ocher 2 surface
3	P 3371	Jug	Many minute mixed grits, naples yellow 2
	P 3888	Jug	Same type as No. 3; LB I
4	P 3886	Lamp	Few minute mixed grits, brown ocher 2
TOMB 1100 A			
5	P 4387	Bowl	Many predominantly light grits, brown ocher 2, traces of spaced ring burnishing inside (see p. 152)
	P 4314 P 4319-20 P 4324-25 P 4392	Bowls	Same type as No. 5 with variations in firing and color (see Figs. 105-7 and 109); LB I
6	P 4413	Bowl	Many predominantly light grits, blue-black 2 core, naples yellow 2 surface. See Pl. 143:1 for photograph.
	P 4313 P 4385 P 4391 P 4408	Bowls	Same type as No. 6 except for brown ocher 2 surface and spaced ring burnishing inside (P 4408 outside too) (see Figs. 105-6); LB I
7	P 4386	Bowl	Many large light grits, well fired, blue-black 3 core, brown ocher 2 surface, spaced ring burnishing; badly warped. See Pl. 143:2 for photograph.
8	P 4409	Bowl	Complete, many predominantly light grits, brown ocher 2 surface, spaced ring burnishing (see p. 152). See Pl. 143:3 for photograph.
	P 4305 P 4307-11 P 4410	Bowls	Same type as No. 8 with variations in firing and color (see Figs. 105 and 107-10); LB I
9	P 4384	Bowl	Fine ware, few minute light grits, well made, well fired, blue-black 3 core, naples yellow 3 slip, close ring burnishing. See Pl. 143:4 for photograph.
10	P 4421	Bowl	Many minute light grits, well made, naples yellow 2, spaced ring burnishing outside. See Pl. 143:5 for photograph.
	P 4429 P 4431	Bowls	Same type as No. 10 except for permanent yellow 3 core and surface (see Fig. 109); LB I
11	P 4286	Bowl	Intact, fine ware, few minute light grits, well made, well fired, naples yellow 2 surface, spaced ring burnishing; warped. See Pl. 143:6 for photograph.
12	P 4285	Bowl	Intact, many minute light grits, well made, naples yellow 3 surface, traces of spaced ring burnishing. See Pl. 143:7 for photograph.
13	P 4306	Bowl	Intact, many minute light grits, well made, well fired, brown ocher 2 surface, spaced ring burnishing outside (see p. 152). See Pl. 143:8 for photograph.
14	P 4312	Bowl	Intact, many minute light grits, brown ocher 1 surface, traces of spaced ring burnishing (see p. 152). See Pl. 143:9 for photograph.
	P 4420	Bowl	Same type as No. 14; LB I
15	P 4283	Jug	Intact, many minute light grits, naples yellow 2 surface, traces of vertical burnishing
16	P 4399	Jug	Many minute light grits, brown ocher 2, close vertical burnishing on body, irregular burnishing on base. See Pl. 143:10 for photograph.
17	P 4419	Jug	Many minute mixed grits, blue-black 3 core, brown ocher 2 surface, traces of vertical burnishing
	P 4398	Jug	Same shape as No. 17, many minute mixed grits, burnt umber 3 core, blue-black 1 surface, close vertical burnishing on body and irregular burnishing on base; LB I
	P 4402 P 4405	Jugs	Same type as No. 17 except for brown ocher 2 core; P 4402 found in P 4305 (see above); LB I
18	P 4395	Jug	Many minute mixed grits, brown ocher 2, close vertical burnishing on body and ring burnishing on base, roman sepia 1 and indian red 2 decoration. See Pl. 143:11 for photograph.
19	P 4282	Jug	Intact, fine ware, few minute dark grits, well fired, permanent yellow 3 surface, black and white decoration, handmade; Cypriote (see p. 153). See Pl. 143:12 for photograph.
20	P 4396	Jug	Few minute mixed grits, black lead 3, spaced vertical burnishing (see p. 151)
	P 4424	Jug	Same type as No. 20; LB I
21	P 4381	Jug	Same as No. 20. See Pl. 143:13 for photograph.
	P 4397	Jug	Same type as No. 21; LB I
22	P 4476	Jug	Many minute mixed grits, blue-black 3 core, brown ocher 2 surface, traces of light red 2 wash or decoration
23	P 4275	Jug	Intact, many minute mixed grits, brown ocher 2 surface, spaced vertical burnishing. See Pl. 143:14 for photograph.
	P 4274 P 4475 P 4477	Jugs	Same type as No. 23 with variations in color (P 4274 not burnished); LB I
24	P 4401	Jug	Many minute light grits, blue-black 3 core, permanent yellow 3 surface, spaced vertical burnishing
	P 4321	Jug	Same type as No. 24 except for brown ocher 2 core and surface; LB I
25	P 4400	Jug	Many minute mixed grits, burnt umber 2, traces of vertical burnishing. See Pl. 143:15 for photograph.
26	P 4280	Jug	Intact, many minute mixed grits, well fired, chiefly brown ocher 2 surface, spaced vertical burnishing, vertical shaving
27	P 4278	Jug	Intact, many minute light grits, permanent yellow 3 surface, spaced vertical burnishing. See Pl. 143:16 for photograph.
	P 4277 P 4297 P 4404	Jugs	Same type as No. 27; P 4297 found in P 4380 (see opp. Pl. 46), P 4404 in P 4417 (Pl. 46:6); LB I
28	P 4403	Jug	Some minute mixed grits, brown ocher 2, spaced vertical burnishing. See Pl. 143:17 for photograph.
	P 4298 P 4426-28	Jugs	Same type as No. 28 (see Figs. 109-10); P 4298 found in No. 14; LB I
29	P 4273	Jug	Intact, some minute light grits, permanent yellow 3 surface. See Pl. 143:18 for photograph.
	P 4276 P 4293	Jugs	Same type as No. 29, with spaced vertical burnishing (see Figs. 109-10); LB I
30	P 4294	Jug	Intact, many minute mixed grits, naples yellow 2 surface, spaced vertical burnishing. See Pl. 143:19 for photograph.
	P 4272 P 4322	Jugs	Same type as No. 30 (see Fig. 110); LB I
31	P 4430	Jug	Same as No. 27
32	P 4299	Jug	Intact; same as No. 27 except for pellet on handle; found in P 4318 (Pl. 46:14). See Pl. 143:20 for photograph.
33	P 4271	Jug	Intact, many minute light grits, chiefly brown ocher 2 surface, spaced vertical burnishing
	P 4279	Jug	Same type as No. 33 except for no burnishing; LB I
34	P 4292	Jug	Intact; same as No. 27. See Pl. 143:21 for photograph.

TOMB 921

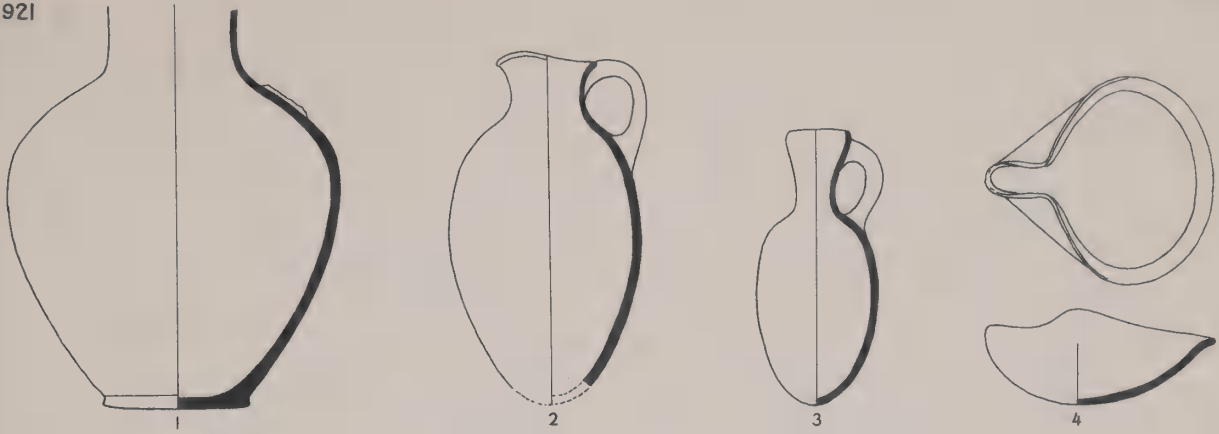

TOMB 1100 A

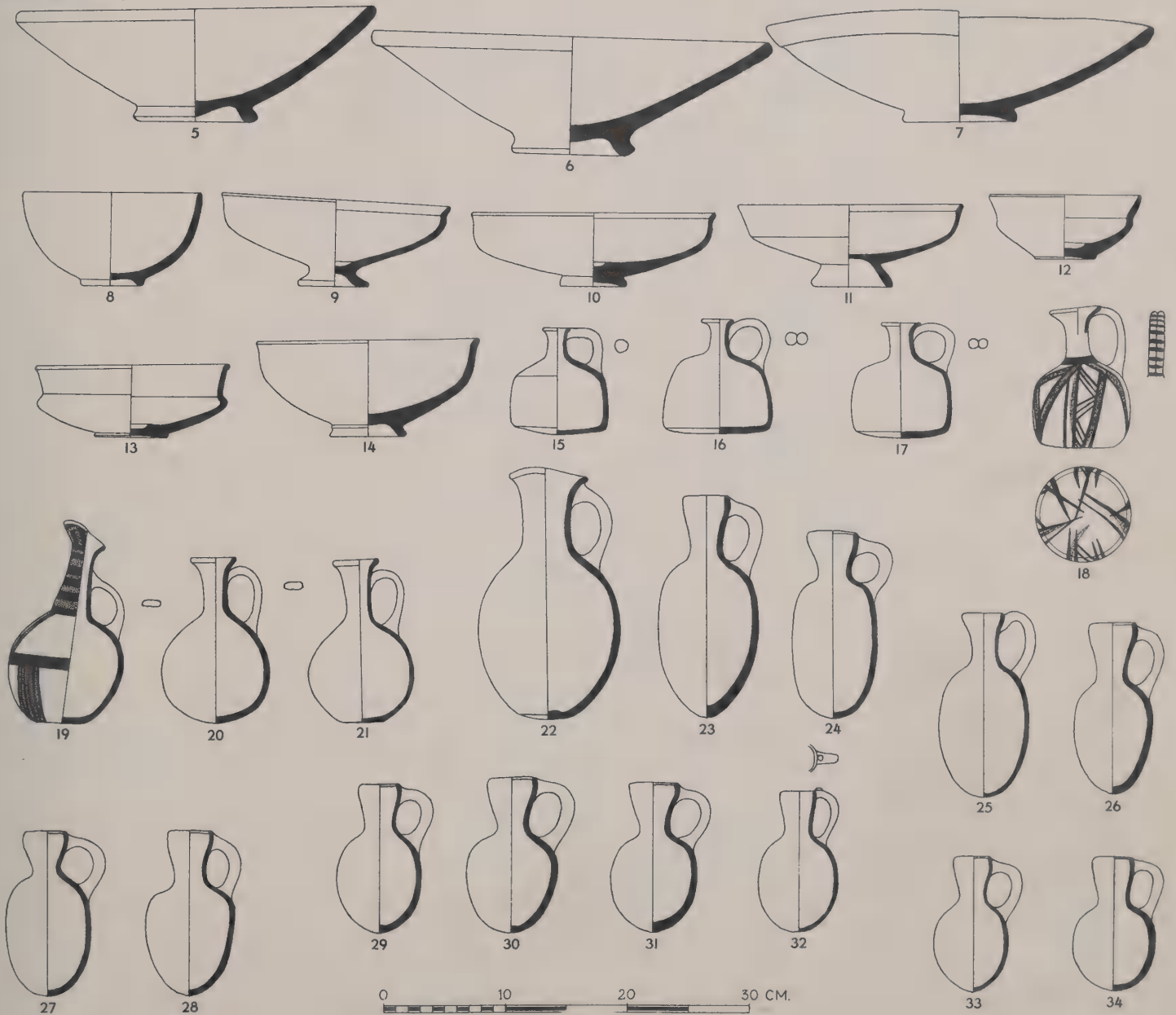

LB I POTTERY FROM TOMBS 921 AND 1100 A (SEE PP. 87-89). SCALE, 1:5

No.	Field No.	Description
1	P 4295	Intact, many light grits, well fired, permanent yellow 3 surface. See Pl. 143:22 for photograph.
2	P 4425	Many mixed grits, brown ocher 2, traces of spaced horizontal burnishing
3	P 4323	Complete, many mixed grits, permanent brown 3 core, brown ocher 3 surface, traces of spaced vertical burnishing. See Pl. 143:25 for photograph.
	P 4382	Same as No. 3 except for naples yellow 2 surface and no burnishing (see Fig. 105); LB I
4	P 4383	Many predominantly light grits, well made, brown ocher 3, traces of vertical burnishing. See Pl. 143:26 for photograph.
	P 4284 } P 4380 } P 4406 }	Same type as No. 4 (see Figs. 106-7); LB I
5	P 4377	Many light grits, well made, black lead 3 core, permanent yellow 3 surface, horizontal burnishing(?), incised decoration and pottery mark, pellet on handle (see p. 151); warped. See Pl. 143:27 for photograph.
6	P 4417	Many light grits, well made, brown ocher 3. See Pl. 143:28 for photograph.
	P 4416	Same shape as No. 6, many mixed grits, blue-black 3 core, brown ocher 2 surface (see Fig. 109); LB I
7	P 4296	Intact, many light grits, burnt umber 3 to naples yellow 3 surface, spaced vertical burnishing. See Pl. 143:23 for photograph.
8	P 4407	Many light grits, well made, blue-black 3 core, brown ocher 2 to naples yellow 2 surface, incised decoration
	P 4418	Same as No. 8 except for being well fired and without decoration (see Fig. 107); LB I
9	P 4300	Intact, many mixed grits, well made, brown ocher 3 surface. See Pl. 143:24 for photograph.
10	P 4316	Complete, some light grits, well fired, permanent yellow 3. See Pl. 144:2 for photograph.
11	P 4281	Intact, many light grits, well made, brown ocher 3 surface. See Pl. 144:6 for photograph.
12	P 4411	Many light grits, brown ocher 2, spaced vertical burnishing, roman sepia 1 and indian red 3 decoration
13	P 4394	Many predominantly light grits, naples yellow 2, spaced vertical burnishing. See Pl. 144:7 for photograph.
14	P 4318	Few minute mixed grits, well made, naples yellow 2 core, naples yellow 3 slip, close horizontal burnishing, indian red 1 decoration. See Pl. 144:5 for photograph.
15	P 4393	Many predominantly light grits, well made, brown ocher 2, roman sepia 1 and indian red 1 decoration (see Fig. 111). See Pl. 144:3 for photograph.
16	P 4303	Intact, many predominantly light grits, well made, brown ocher 2 surface, spaced vertical burnishing, roman sepia 1 and indian red 1 decoration. See Pl. 144:4 (for photograph) and frontispiece.
	P 4301	Same type as No. 16 without burnishing and decoration (see Fig. 110); LB I
	P 4302	Same type as No. 16 without decoration; LB I

TOMB 1100 A

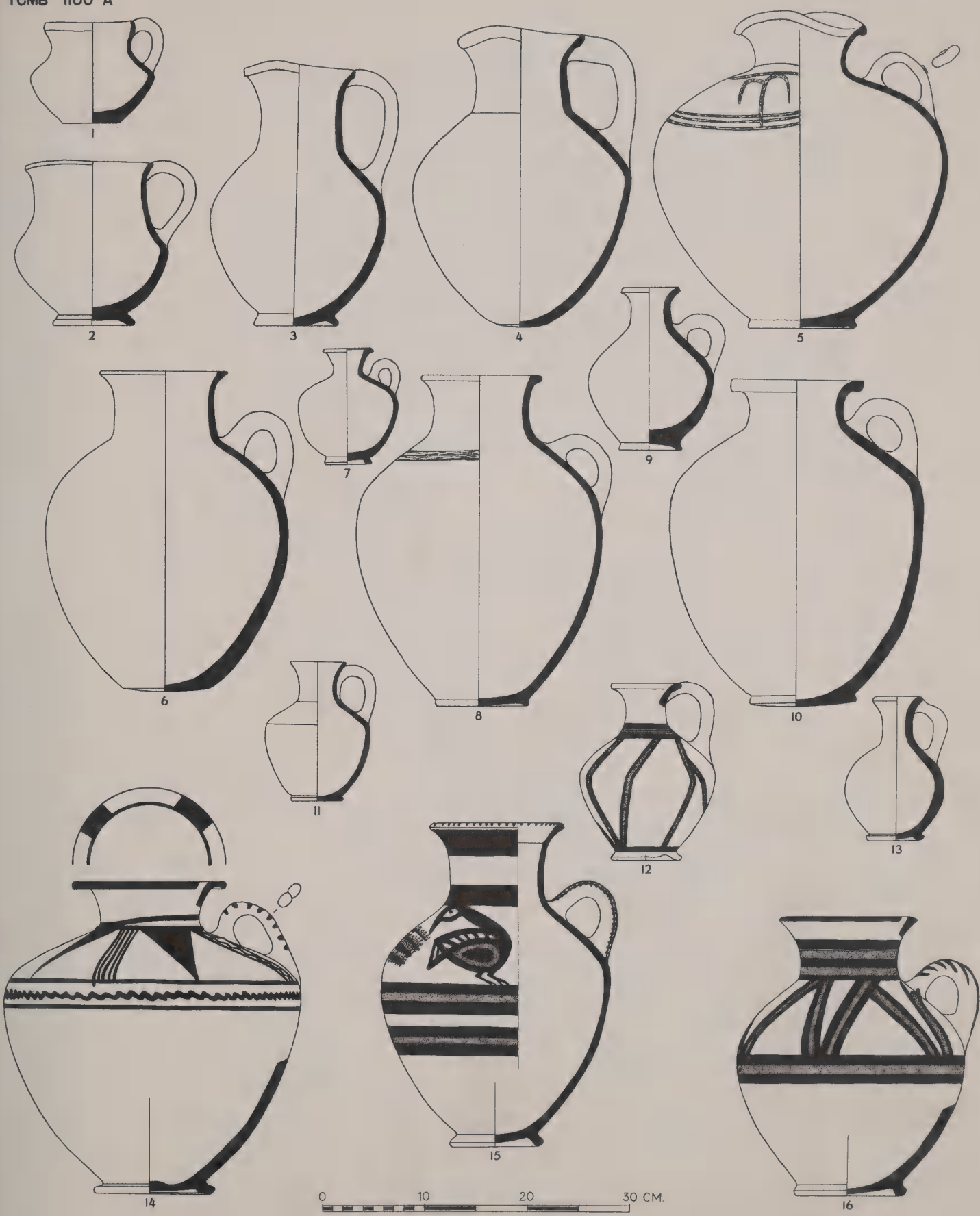

LB I POTTERY JUGS FROM TOMB 1100 A (SEE PP. 88 F.). SCALE, 1:5

No.	Field No.	Designation	Description
TOMB 1100 A			
1	P 4287	Lamp	Intact, brown ocher 3 surface (see p. 151). See Pl. 144:9 for photograph.
	P 4288-91 P 4422-23 }	Lamps	Same type as No. 1, some with many mixed grits and dark core (see Figs. 105 and 107); LB I
2	P 4479	Lamp	Many predominantly light grits, roman sepia 3 core, brown ocher 2 surface
3	P 4304	Bowl	Intact, well made, brown ocher 2 surface, spaced horizontal burnishing, 4 suspension holes (see p. 152). See Pl. 144:10 for photograph.
4	P 4412	Jar	Some minute light grits, blue-black 2, spaced horizontal burnishing on body, irregular burnishing on base (see p. 152). See Pl. 144:8 for photograph.
5	P 4388	Jar	Many predominantly light grits, well made, well fired, permanent yellow 3. See Pl. 144:11 for photograph.
	P 4378	Jar	Moderately fired specimen of same type as No. 5 except for blue-black 3 core and naples yellow 2 surface; LB I
	P 4414 } P 4480 }	Jars	Same type as No. 5 except for naples yellow 2 core and surface; LB I
6	P 4379	Jar	Well made, brown ocher 2 core, naples yellow 2 surface; warped. See Pl. 144:12 for photograph.
	P 4415	Jar	Same shape as No. 6, many light grits, well made, permanent yellow 3; LB I
	P 4478	Flask	Intrusive; LB II
TOMB 1100 B			
7	P 4435	Bowl	Fine ware, some minute light grits, well made, brown ocher 3. See Pl. 145:12 for photograph.
8	P 4444	Bowl	Fine ware, some minute light grits, well made, naples yellow 2, close ring burnishing outside. See Pl. 145:13 for photograph.
9	P 4434	Milk bowl	Fine ware, few minute dark grits, well fired, burnt umber 1 core, indian red 1 wash, handmade; Cypricote (see p. 153)
10	P 4436	Jar	Many mixed grits, well made, blue-black 3 core, brown ocher 2 surface, blue-black 2 and indian red 1 decoration. See Pl. 145:16 for photograph.
11	P 4357	Jug	Intact, few minute mixed grits, warm sepia 2 surface, close vertical burnishing, pellet on double handle (see p. 151). See Pl. 145:17 for photograph.
12	P 4440	Jug	Many mixed grits, blue-black 3, blue-black 1 and indian red 2 decoration. See Pl. 145:15 for photograph.
	P 4432-33	Bowls	Same type as Pl. 45:14; LB I
	P 4439 } P 4443 }	Bowls	Same type as Pl. 45:5; LB I
	P 4445	Bowl	Same type as Pl. 45:11; LB I
	P 4456	Jar	Same type as No. 5 above (see Fig. 106); LB I
	P 3982 } P 4356 }	Jugs	Same type as Pl. 46:4 (see Fig. 106); LB I
	P 4438	Jug	Same type as Pl. 45:17 except for no burnishing; LB I
	P 4441	Jug	Same type as Pl. 45:23 except for naples yellow 2 core and surface and no burnishing (see Fig. 106); LB I
	P 4442	Jug	Same type as Pl. 45:30; LB I
	P 4447	Jug	Same type as Pl. 45:21 except for slightly ruddy surface; LB I
	P 4437	Lamp	Same type as No. 1 above; LB I
TOMB 1100 C			
13	P 4327	Bilbil	Intact, fine ware, few minute mixed grits, well made, well fired, blue-black 2, close irregular burnishing, raised decoration, handmade; Cypricote (see p. 154). See Pl. 147:1 for photograph.
14	P 4335	Jug	Intact, some light grits, well made, chiefly brown ocher 3 surface, close horizontal burnishing, roman sepia 1 and indian red 1 decoration. See Pl. 147:3 for photograph.
15	P 4334	Jug	Intact; same as No. 14 except for naples yellow 3 surface. See Pl. 147:2 for photograph.
16	P 4337	Jug	Intact, many mixed grits, well made, brown ocher 3 surface, traces of horizontal burnishing, roman sepia 1 and indian red 1 decoration
17	P 4336	Jug	Intact; same as No. 16 except for spaced vertical burnishing. See Pl. 147:5 for photograph.

TOMB 1100A

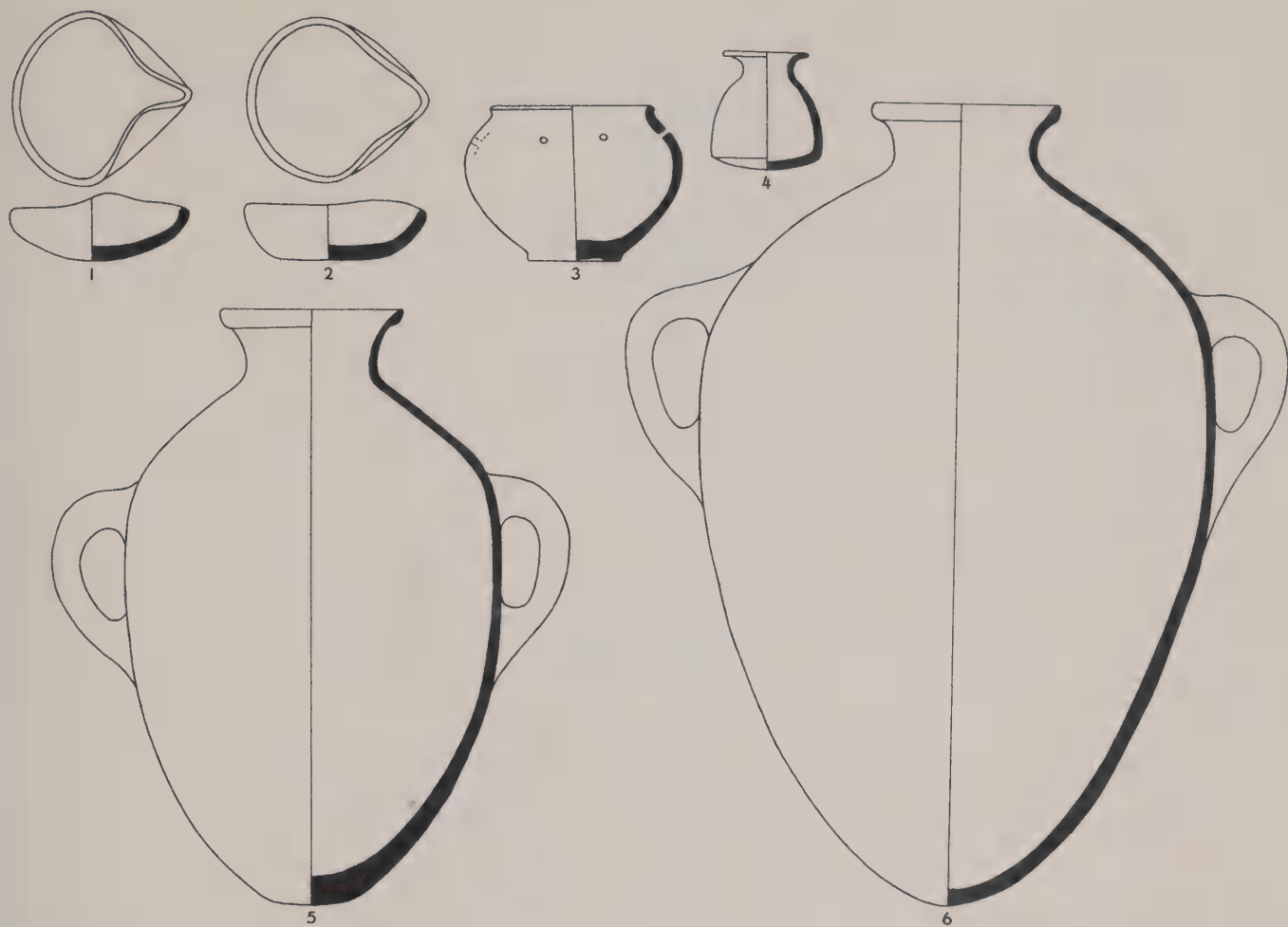

TOMB 1100B

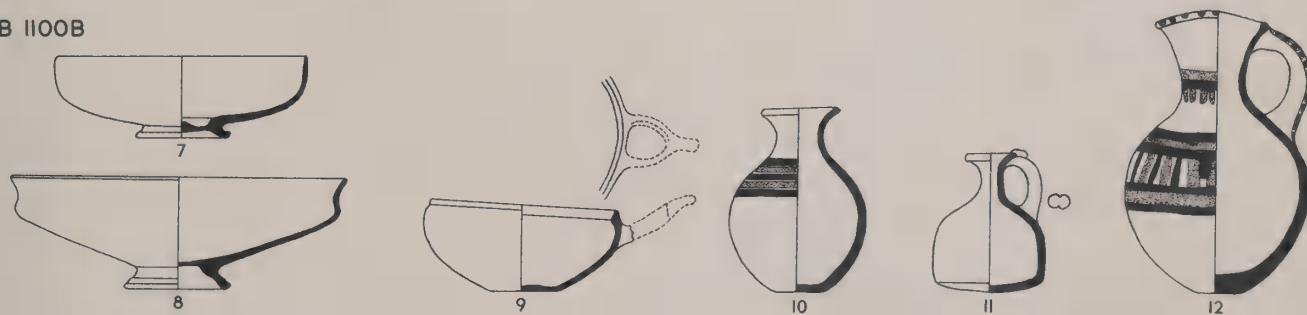

TOMB 1100C

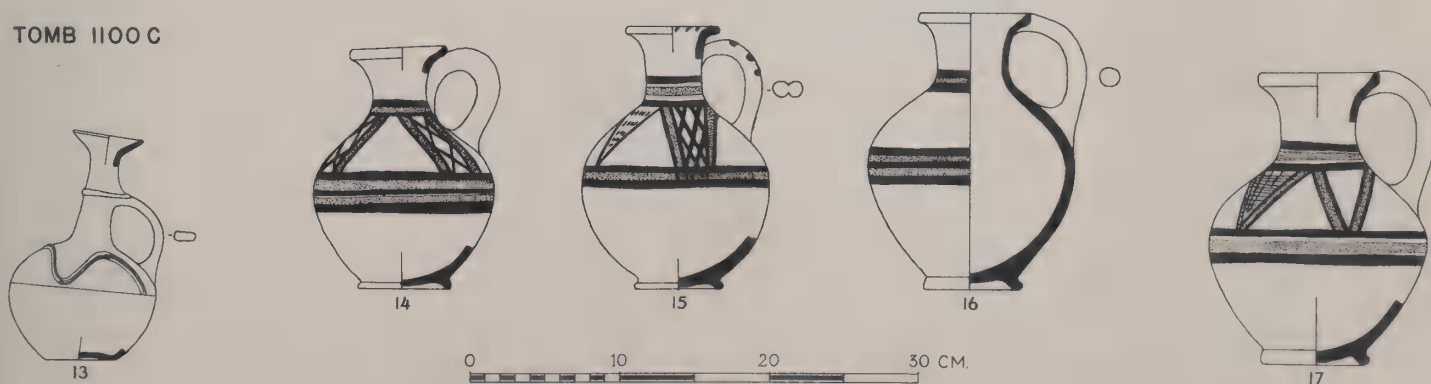

0 10 20 30 CM.

No.	Field No.	Designation	Description
TOMB 1100 C			
1	P 4346	Jug	Many mixed grits, well made, brown ocher 2, spaced horizontal burnishing, indian red 2 decoration
2	P 4329	Jug	Intact, well made, brown ocher 2 surface, close vertical burnishing, roman sepia 1 and indian red 1 decoration
3	P 4358	Jug	Complete, fine ware, few minute mixed grits, well made, well fired, permanent yellow 3 slip, close vertical burnishing, blue-black 2 and indian red 1 decoration (see p. 154). See Pl. 147:6 for photograph.
4	P 4452	Jug	Brown ocher 1. See Pl. 147:8 for photograph.
5	P 4453	Jug	Many mixed grits, brown ocher 2, traces of burnishing
6	P 4339	Jug	Intact, brown ocher 2 surface, spaced vertical burnishing. See Pl. 147:7 for photograph.
7	P 4448	Jar	Brown ocher 2, traces of burnishing, indian red 1 decoration; rim reconstructed from No. 11 on Pl. 147
8	P 4347	Milk bowl	Intact, fine ware, few minute mixed grits, burnt umber 3 surface, chiefly indian red 1 wash, handmade; Cypriote. See Pl. 147:10 for photograph.
	P 4330	Milk bowl	Same type as No. 8 (see Fig. 107); LB I
9	P 4351	Bowl	Intact, brown ocher 2 surface. See Pl. 147:9 for photograph.
10	P 4353	Bowl	Intact, many mixed grits, well fired, brown ocher 2 surface, spaced ring burnishing outside
	P 4431-32 } P 4348 } P 4450-51 }	Bowls	Same type as Pl. 45:14 with minor variations in color and some with no burnishing (see Figs. 107 and 110); LB I
	P 4349	Bowl	Same type as Pl. 45:9 (see Figs. 109-10); LB I
	P 4350	Bowl	Same type as Pl. 45:7 except for permanent yellow 3 surface; LB I
	P 4352	Bowl	Same type as Pl. 45:13 (see Fig. 110); LB I
	P 4449	Bowl	Same type as Pl. 45:10; LB I
	P 4328	Jug	Same type as Pl. 45:25 except for brown ocher 2 surface; LB I
	P 4333	Jug	Same type as Pl. 45:20 except for blue-black 2 surface; LB I
	P 4338	Jug	Same type as Pl. 144:1; LB I
	P 4340	Jug	Same type as Pl. 46:3; LB I
	P 4341	Jug	Same type as Pl. 45:28; LB I
	P 4342-43 } P 4345 }	Jugs	Same type as Pl. 45:27 (see Fig. 110); P 4345 found in P 4355 (see below); LB I
	P 4344	Jug	Same type as Pl. 46:1 except for brown ocher 2 surface; LB I
	P 4455	Jug	Same type as Pl. 45:20 except for warm sepia 3 surface; LB I
	P 4355 } P 4389 }	Jars	Same shape as Pl. 47:6, many light grits, well made, well fired, permanent yellow 3; warped (see Fig. 107); LB I
	P 4354	Lamp	Same shape as Pl. 47:1, many minute mixed grits, well fired, permanent yellow 3 (see Fig. 110); LB I
	P 4454	Lamp	Same type as Pl. 47:1; LB I
TOMB 1100 D			
11	P 4460	Bowl	Fine ware, few minute grits, well made, well fired, brown ocher 2 core, naples yellow 3 slip, close ring burnishing (see p. 151). See Pl. 148:7 for photograph.
12	P 4459	Bowl	Same as No. 11 except for naples yellow 2 core. See Pl. 148:8 for photograph.
13	P 4368	Jug	Intact, many mixed grits, well made, brown ocher 2 surface, spaced vertical burnishing. See Pl. 148:12 for photograph.
14	P 4369	Jug	Well made, brown ocher 3, spaced vertical burnishing, roman sepia 1 and indian red 2 decoration. See Pl. 148:11 for photograph.
15	P 4457	Jug	Many minute mixed grits, well made, brown ocher 2, roman sepia 1 and indian red 1 decoration (decoration on shoulder too indistinct to be drawn). See Pl. 148:10 for photograph.
16	P 4470	Jug	Many mixed grits, brown ocher 3, spaced vertical burnishing. See Pl. 148:13 for photograph.
17	P 4365	Jug	Intact, few minute mixed grits, well made, naples yellow 3 surface, pellet on handle (see pp. 149 and 151). See Pl. 148:9 for photograph.
18	P 4466	Jug	Fine ware, blue-black 2, close vertical burnishing on body and close straight-line burnishing on base, pellet on double handle (see p. 151)
	P 4370 } P 4372 } P 4463-64 }	Bowls	Same type as Pl. 45:5 (see Fig. 105); LB I
	P 4371 } P 4375 } P 4462 }	Bowls	Same type as Pl. 45:8 with minor variations in grits and color and no burnishing inside (see Fig. 105); LB I
	P 4373	Bowl	Well fired specimen of same type as Pl. 45:10 except for permanent yellow 3 surface and close ring burnishing; LB I
	P 4374	Bowl	Same type as Pl. 45:11 except for brown ocher 2 surface and no burnishing inside; LB I
	P 4458	Bowl	Same type as No. 9 above; LB I
	P 4461	Bowl	Same type as Pl. 45:14 except for no burnishing inside; LB I
	P 4360-62 } P 4367 }	Jugs	Same type as Pl. 45:28 (see Fig. 105); P 4360 found in P 4359 (see below); LB I
	P 4363 } P 4366 }	Jugs	Same type as Pl. 45:27 except for no burnishing (see Fig. 108); LB I
	P 4364	Jug	Same type as Pl. 45:29; LB I
	P 4465	Jug	Same type as Pl. 47:11; LB I
	P 4467	Jug	Same type as Pl. 45:21; LB I
	P 4468	Jug	Same type as Pl. 45:23; LB I
	P 4469	Jug	Same type as No. 6 above (see Fig. 108); LB I
	P 4359 } P 4473 }	Jars	Well fired specimens of same type as Pl. 47:6 except for many light grits (see Fig. 105); LB I
	P 4376 } P 4471-72 }	Lamps	Same type as Pl. 47:1 (see Fig. 108); LB I

TOMB 1100 C

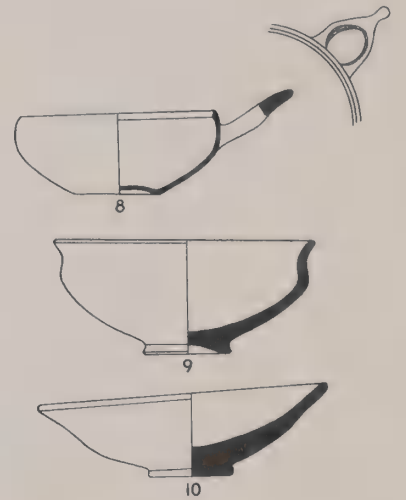
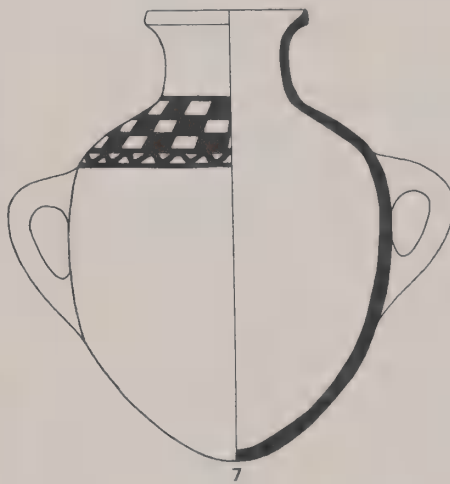
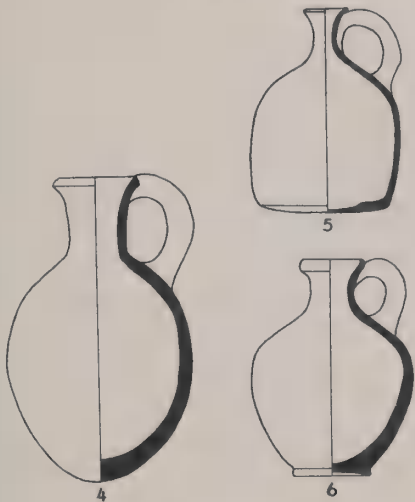
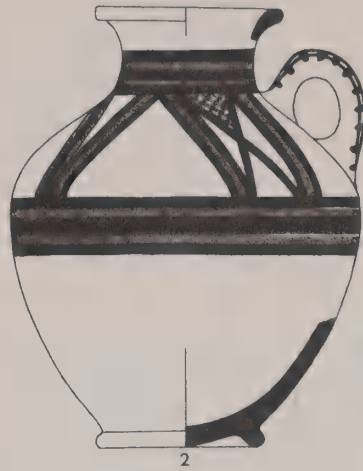
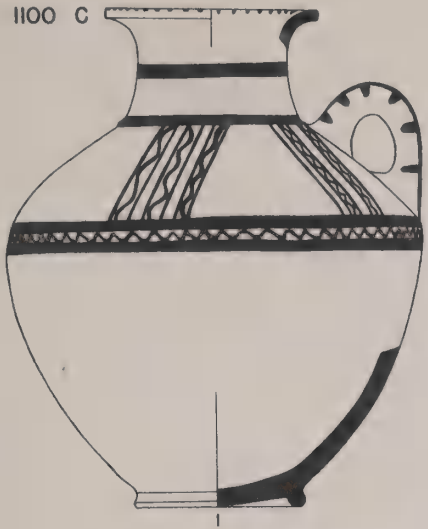

TOMB 1100 D

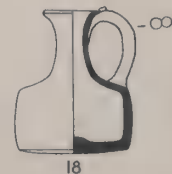
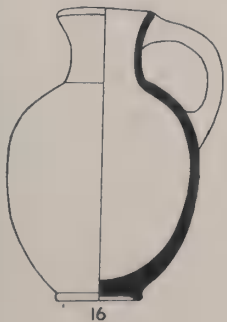
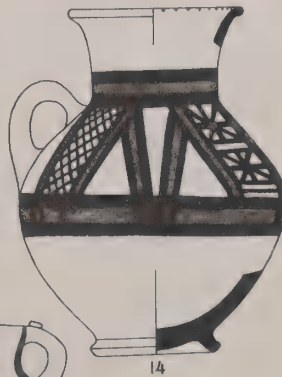
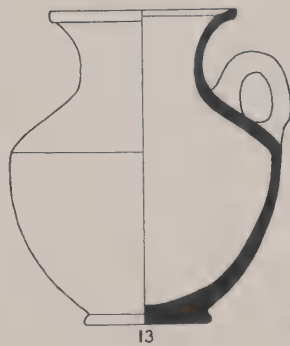
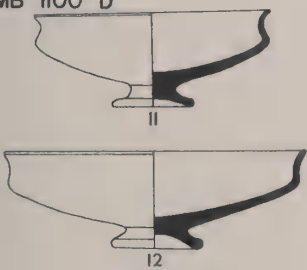

LB I POTTERY FROM TOMB 1100 (SEE PP. 88 F.). SCALE, 1:5

No.	Field No.	Designation	Description	Date*	
TOMB 1141					
1	P 4255	Bowl	Many predominantly light grits, brown ocher 3	LB I	
2	P 4256	Bowl	D. .188, some minute mixed grits, well made, well fired, blue-black 3 core, naples yellow 3 slip, close ring burnishing	LB I	
3	P 4268	Cooking bowl	Poorly made, lightly fired, roman sepia 2 core, burnt umber 1 surface. See Pl. 150:3 for photograph.	LB I	
4	P 4253	Jug	Fine ware, few minute mixed grits, well made, black lead 3 core, blue-black 3 to black lead 1 surface, traces of brown ocher wash, spaced vertical burnishing	LB I	
5	P 4260	Jug	Many large light grits, well fired, burnt umber 3 to naples yellow 3, spaced horizontal burnishing, roman sepia 1 and light red 1 decoration. See Pl. 150:4 for photograph.	LB I	
6	P 4269	Jar	Some light grits, naples yellow 2	LB I	
7	P 4265	Lamp	Intact, many mixed grits, brown ocher 3 surface. See Pl. 150:5 for photograph.	LB I	
	P 4261-64	Lamps	Same type as No. 7	LB I	
8	P 4267	Lamp	Intact, some minute mixed grits, naples yellow 2 surface. See Pl. 150:6 for photograph.	LB I	
9	P 4266	Lamp	Brown ocher 3. See Pl. 150:7 for photograph.	LB I	
10	P 4257	Platter	D. .340, many light grits (calcite), permanent brown 3 core, brown ocher 2 surface, spaced ring burnishing inside and on rim, incised decoration on rim, many short deep incisions on base (see Pl. 150:2), handmade	LB I	
11	P 4258	Sherd	Many minute light grits, blue-black 3 core, burnt umber 3 surface, incised decoration on bands of relief, probably handmade (cf. Petrie, <i>Gaza</i> I, Pl. XXXII 54). See Pl. 150:1 for photograph.	LB I	
12	P 4259	Jar	Rim d. .135, predominantly light grits, blue-black 3 core, naples yellow 2 surface, pottery mark, handmade	Stages I-IV. Col. 12 A	
13	P 4254	Jug	Many light grits, blue-black 3 core, chiefly burnt umber 2 surface, traces of close vertical burnishing	Stages III-IV?	
TOMB 1145 A					
14	P 4234	Bowl	Many light grits, blue-black 3 core, naples yellow 2 surface	LB I	
15	P 4218	Bowl	Poorly made, well fired, blue-black 3 core, naples yellow 3 surface	LB I	
16	P 4237	Bowl	Some light grits, blue-black 3 core, naples yellow 2 surface. See Pl. 150:13 for photograph.	LB I	
	P 4221 P 4229-30 P 4242	Bowls	Same type as No. 16 with minor differences in firing and color	LB I	
17	P 4233				Many light grits, blue-black 3 core, brown ocher 3 surface
18	P 4231				Many light grits, poorly made, well fired, blue-black 3 core, burnt umber 3 surface
	P 4217	Bowl	Fairly well made specimen of same type as No. 18	LB I	
19	P 4238	Bowl	Many light grits, naples yellow 2. See Pl. 150:12 for photograph.	LB I	
20	P 4236	Bowl	Many light grits, brown ocher 3. See Pl. 150:14 for photograph.	LB I	
21	P 4241	Bowl	Coarse ware, many predominantly light grits, blue-black 3 core, burnt umber 1 surface	LB I	
	P 4228 P 4243	Bowls	Same type as No. 21 but slightly larger	LB I	
22	P 4219				Bowl
23	P 4225	Milk bowl	Few minute light grits, well fired, burnt umber 2 core, davy's gray 2 slip, irregular burnishing, vandyke brown 3 decoration, handmade; Cypriote (see p. 154)	LB I	
24	P 4220	Milk bowl	Fine ware, few minute light grits, well made, blue-black 3 core, light red 1 wash partially burnt to blue-black 3, polished, handmade; Cypriote (see p. 154)	LB I	
25	P 4226	Bowl	Many light grits, blue-black 3 core, naples yellow 2 surface	LB I	
	P 4227	Bowl	Same type as No. 25	LB I	

\* "Stages" do not date a given piece but indicate the duration of its type. See SAOC No. 10, pp. 52-65 and chart.

TOMB 1141

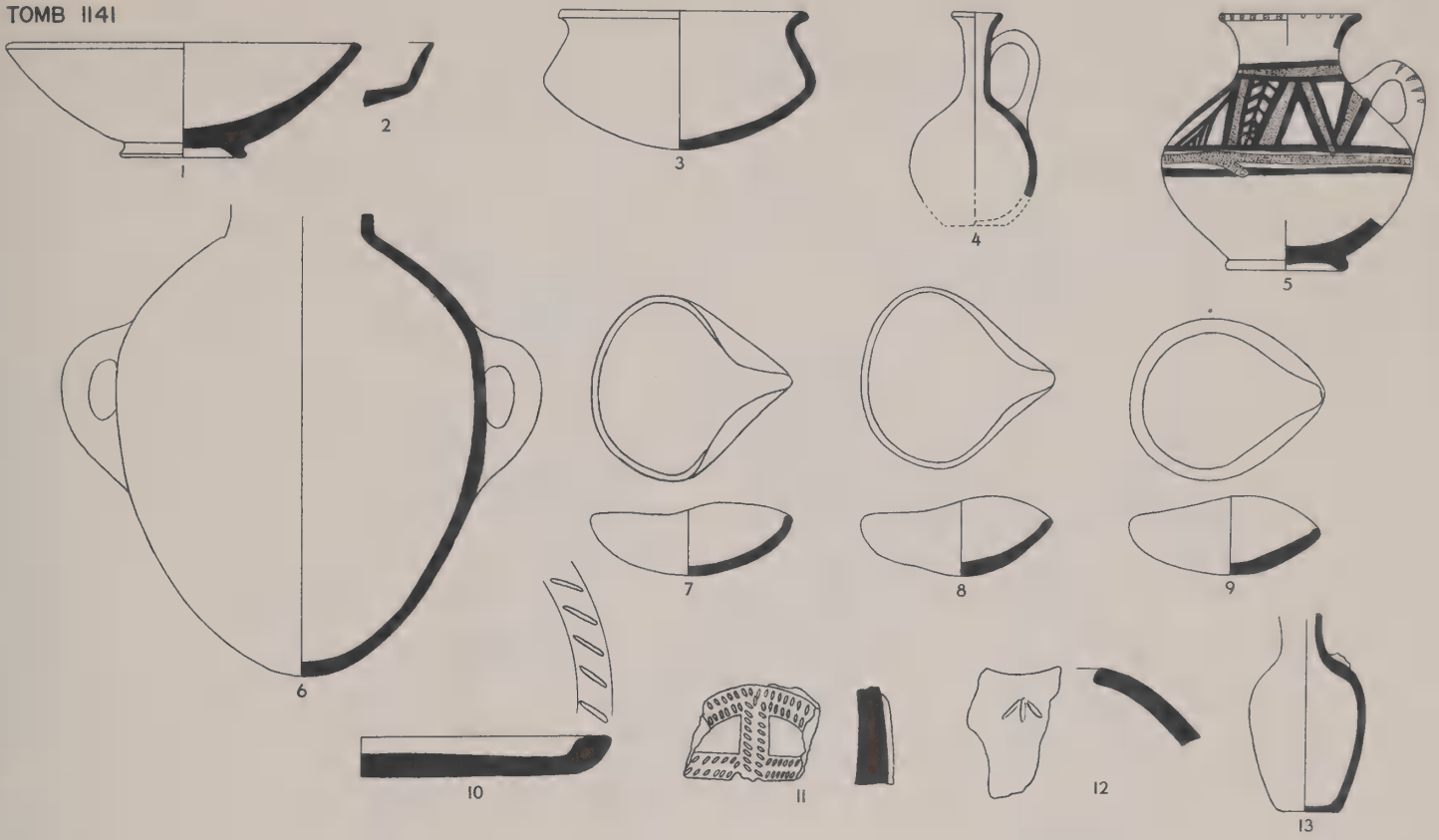

TOMB 1145 A

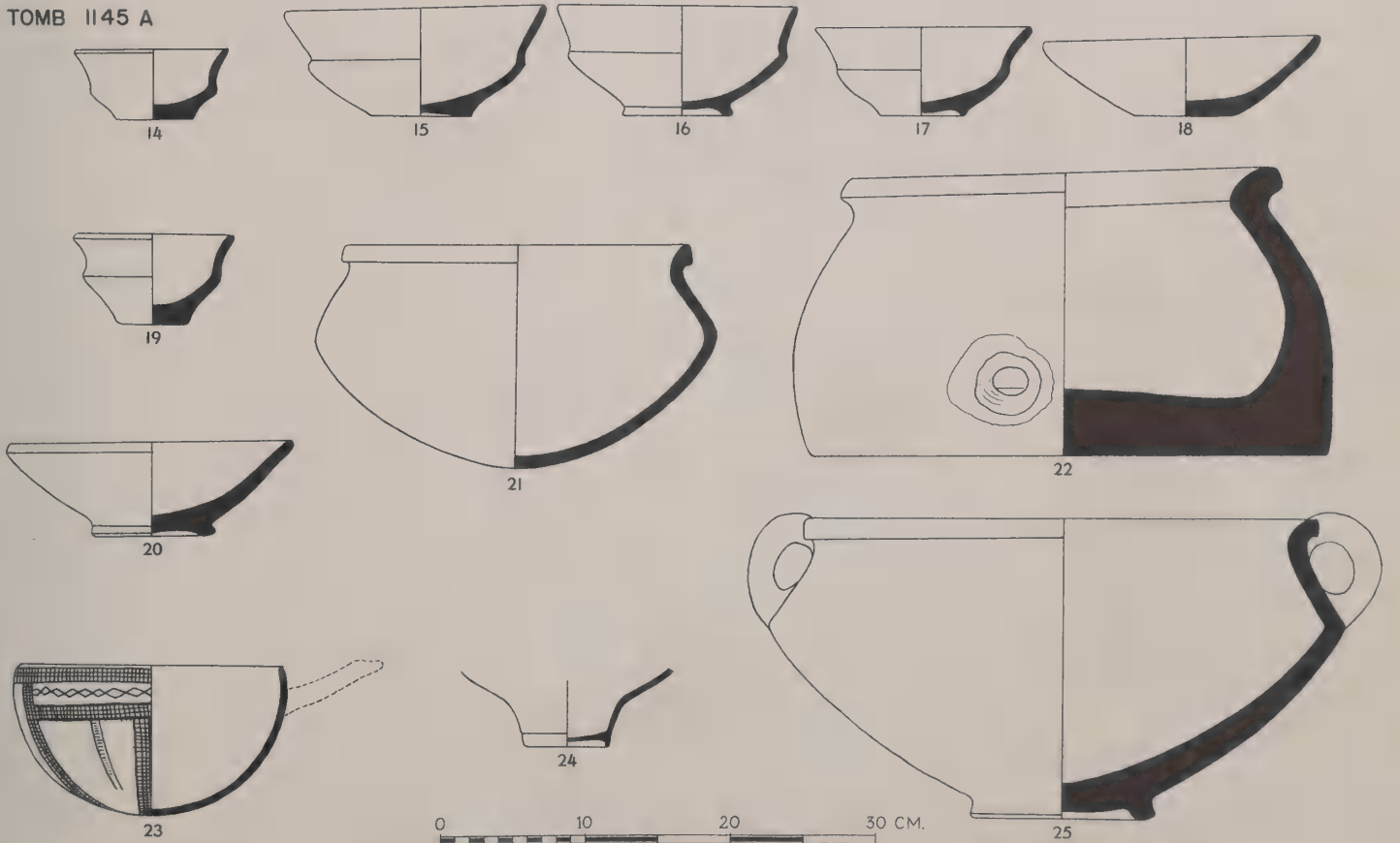

POTTERY FROM TOMBS 1141 AND 1145 A (SEE PP. 94 F.). SCALE, 1:5

No.	Field No.	Designation	Description
TOMB 1145 A			
1	P 4222	Jar-stand	Complete, many predominantly light grits, blue-black 3 core, permanent brown 3 to brown ocher 3 surface; 2 holes in sides, traces of burning inside (see p. 152). See Pl. 150:17 for photograph.
2	P 4235	Jar	Many light grits, blue-black 3 and permanent brown 3 core, chiefly naples yellow 2 surface, roman sepia 1 and light red 1 decoration
	P 4224 P 4239-40 }	Jars	Same type as No. 2 with minor variations in surface color and no decoration; LB I
TOMB 1145 B			
3	P 4162	Bowl	Intact, many light grits, well fired, brown ocher 1 to 2 surface. See Pl. 151:6 for photograph.
4	P 4165	Bowl	Complete, some light grits, brown ocher 2 surface, traces of horizontal burnishing inside. See Pl. 151:5 for photograph.
	P 4166-67 P 4179-80 }	Bowls	Same type as No. 4 (see Figs. 117-18); LB I
5	P 4205	Bowl	Some light grits, brown ocher 2. See Pl. 151:7 for photograph.
6	P 4164	Bowl	Some light grits, naples yellow 2, traces of horizontal burnishing inside. See Pl. 151:8 for photograph.
7	P 4206	Bowl	Complete, some light grits, well fired, naples yellow 2 surface
	P 4163	Bowl	Same type as No. 7 except for more grits and brown ocher 3 surface (see Fig. 117); LB I
8	P 4234	Bowl	Many light grits, blue-black 3 core, brown ocher 2 surface
9	P 4208	Bowl	Same as No. 10 except for naples yellow 2 core and surface
10	P 4209	Bowl	Intact, fine ware, few minute light grits, well made, well fired, brown ocher 2 surface, close ring burnishing. See Pl. 151:3 for photograph.
11	P 4169	Bilbil	Fine ware, some minute light grits, well made, well fired, blue-black 2 to brown ocher 2 slip, polished, raised decoration on body and neck, incised decoration on handle, handmade; Cypriote (see p. 154)
	P 4168	Bilbil	Same type as No. 11; LB I
	P 4170	Bilbil	Same type as No. 11 except for plain handle (see Fig. 117); LB I
12	P 4173	Jug	Fine ware, some minute light grits, blue-black 3 core, blue-black 2 to burnt umber 1 slip, polished, raised decoration, handmade; Cypriote (see p. 154). See Pl. 151:14 for photograph.
13	P 4174	Bilbil	Intact, fine ware, many minute light grits, well made, well fired, blue-black 2 to brown ocher 2 slip, polished, raised decoration on neck, handmade; Cypriote. See Pl. 151:15 for photograph.
14	P 4183	Jug	Intact, many large light grits, naples yellow 2 surface. See Pl. 151:16 for photograph.
15	P 4175	Jug	Intact, fine ware, few minute mixed grits, well made, naples yellow 1 to burnt umber 3 surface, spaced horizontal burnishing
16	P 4181	Jug	Intact, fine ware, few minute mixed grits, well made, naples yellow 2 surface, spaced vertical burnishing. See Pl. 151:19 for photograph.
	P 4176 P 4182 }	Jugs	Same type as No. 16 (see Figs. 117-18); LB I
17	P 4207	Jug	Fine ware, few minute light grits, well made, brown ocher 2, close vertical burnishing
18	P 4177	Jug	Fine ware, few minute grits, well made, naples yellow 2, traces of spaced vertical burnishing
19	P 4188	Jug	Intact, many minute mixed grits, brown ocher 2 surface, traces of vertical burnishing
20	P 4213	Jug	Intact, few minute mixed grits, naples yellow 2 surface, traces of vertical burnishing
21	P 4191	Jug	Fine ware, few minute light grits, well made, naples yellow 3, spaced vertical burnishing. See Pl. 151:20 for photograph.
22	P 4190	Jug	Many minute mixed grits, burnt umber 2, traces of vertical burnishing. See Pl. 151:10 for photograph.
23	P 4197	Jug	Many minute mixed grits, well made, permanent brown 3 core, light red 3 to naples yellow 3 slip or wash, close vertical burnishing, indian red 1 decoration

TOMB 1145 A

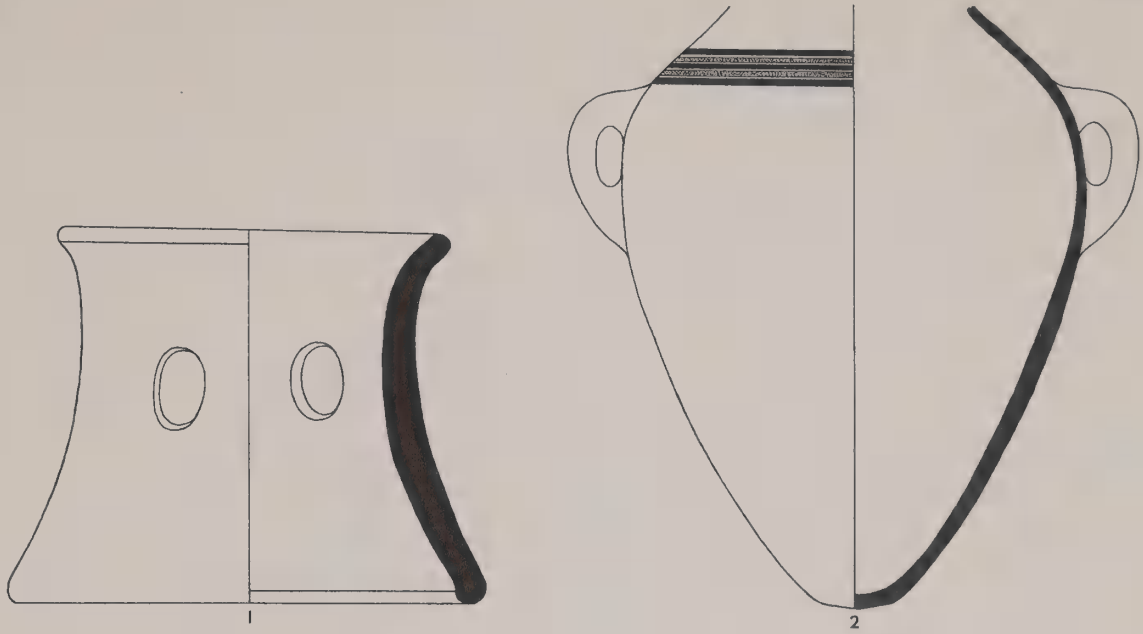

TOMB 1145 B

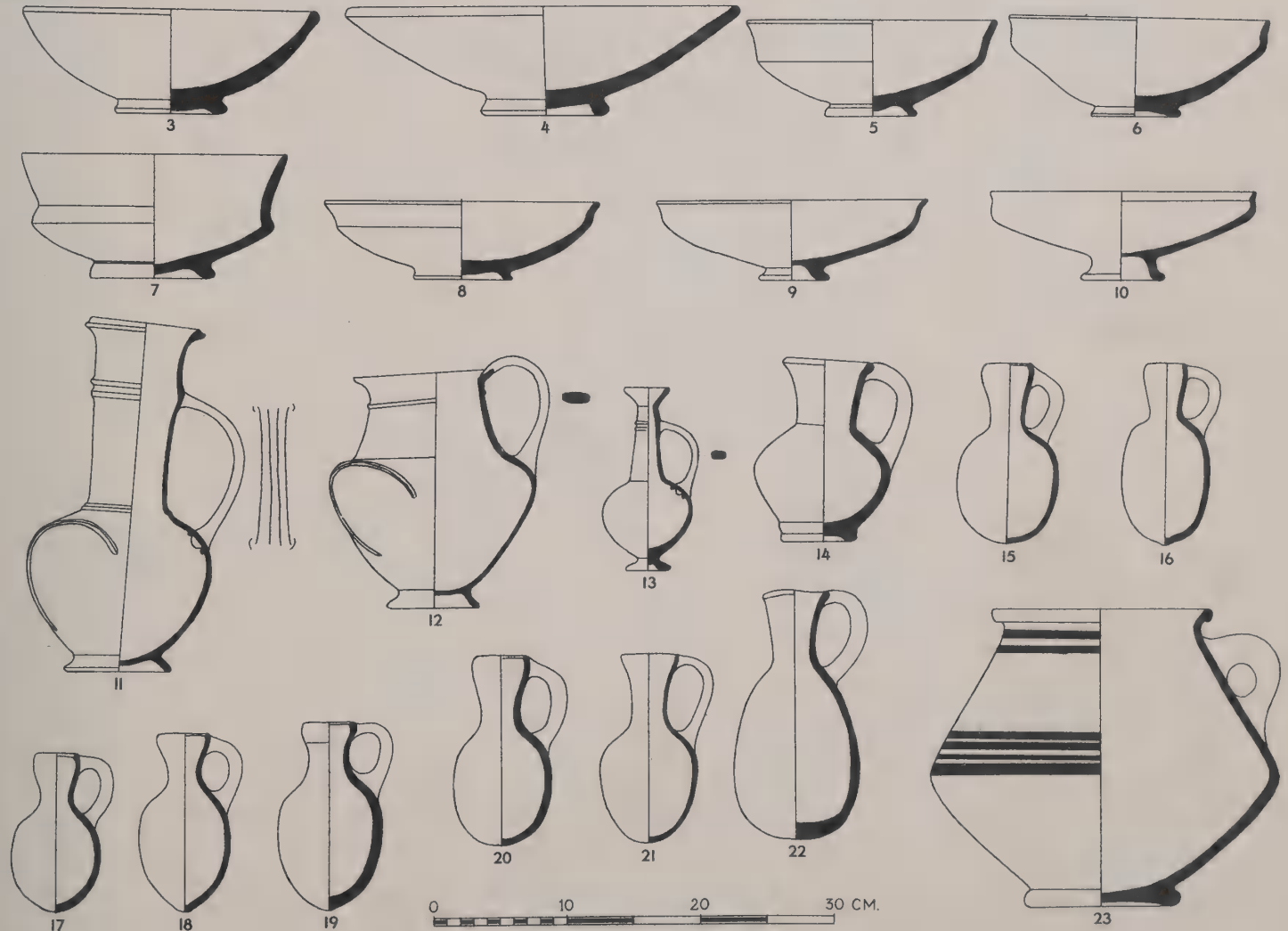

LB I POTTERY FROM TOMB 1145 (SEE PP. 94-99). SCALE, 1:5

No.	Field No.	Designation	Description
1	P 4184	Jug	Intact, well made, brown ocher 2 surface, spaced vertical burnishing, indian red 2 and roman sepia 1 decoration. See Pl. 151:11 for photograph.
2	P 4215	Jug	Some light grits, naples yellow 2 core, permanent yellow 2 surface; warped. See Pl. 151:17 for photograph.
3	P 4161	Jug	Many light grits, well made, naples yellow 2. See Pl. 151:13 for photograph.
4	P 4186	Jug	Complete, many predominantly light grits, naples yellow 2 surface. See Pl. 151:9 for photograph.
	P 4172	Jug	Same type as No. 4 (see Fig. 117); LB I
5	P 4192	Jug	Many light grits, brown ocher 2
6	P 4189	Jug	Many predominantly light grits, brown ocher 2, close horizontal burnishing, light red 1 decoration
7	P 4171	Jar	Intact, some light grits, well fired, naples yellow 2 to 3 surface, close burnishing on neck and shoulder, vandyke brown 1 and light red 2 decoration; warped. See Pl. 151:21 for photograph.
8	P 4212	Jar	Some light grits, well made, brown ocher 2. See Pl. 151:18 for photograph.
9	P 4214	Jar	Many light grits, blue-black 3 core, naples yellow 2 surface

TOMB 1145 B

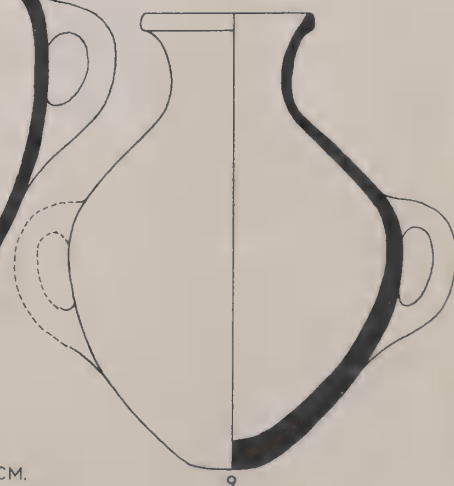
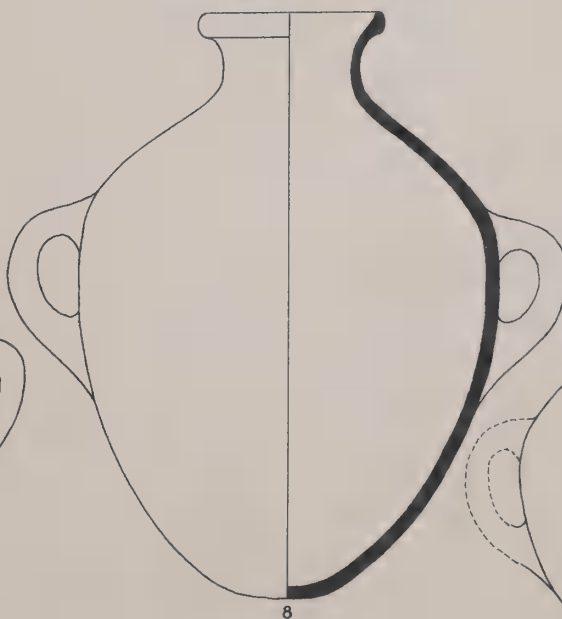
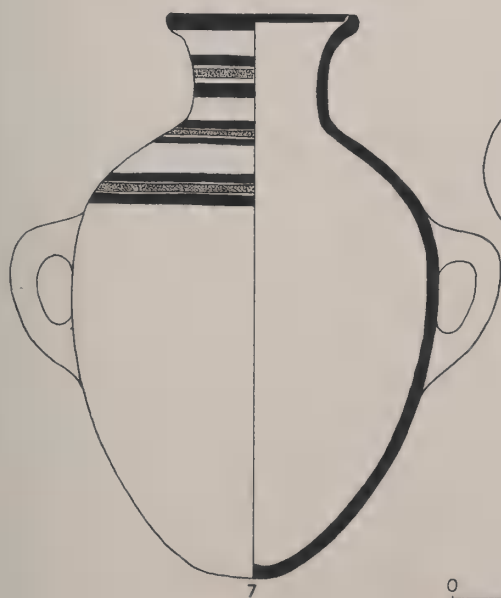
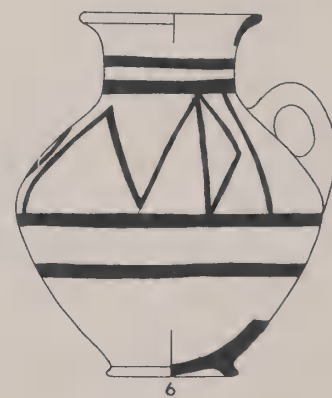
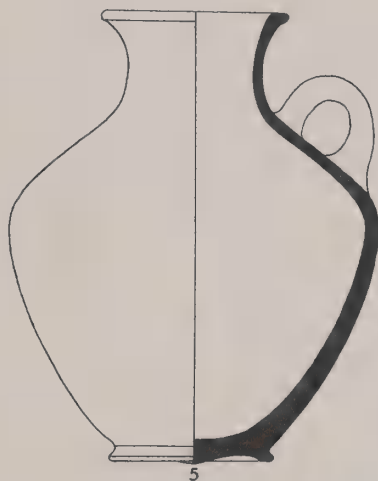
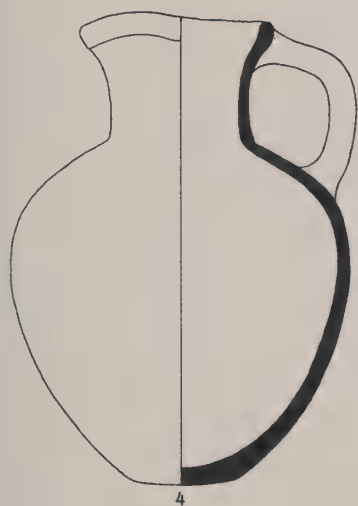
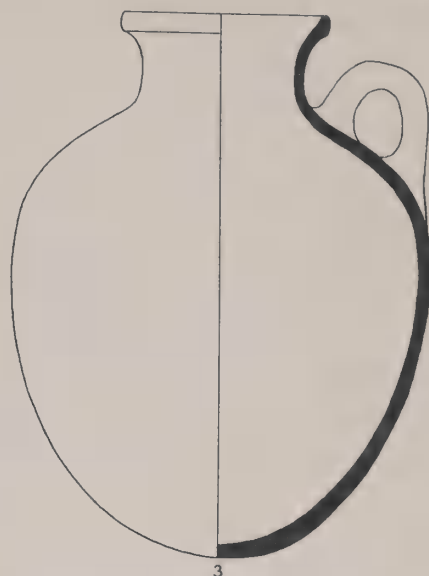
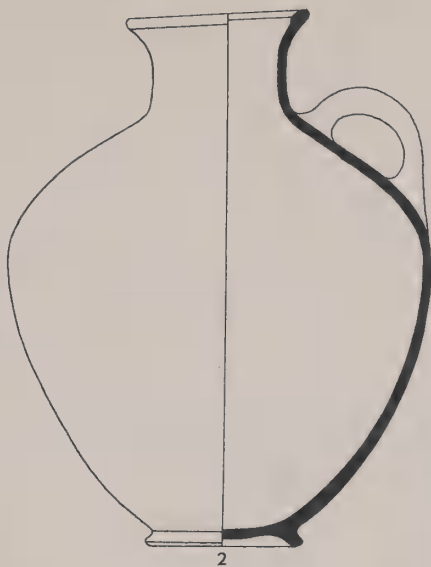
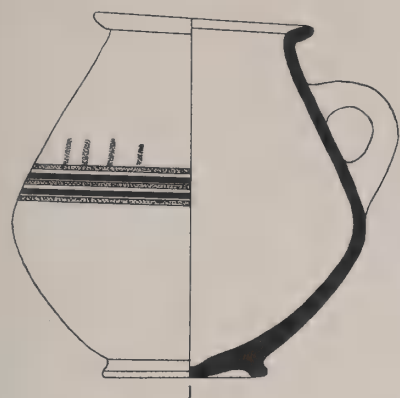

LB I POTTERY FROM TOMB 1145 B (SEE P. 95). SCALE, 1:5

No.	Field No.	Designation	Description
1	P 4187	Jar	Some light grits, blue-black 2 core, burnt umber 2 to permanent brown 3 surface (see p. 151)
2	P 4159	Jar	Well made, many large light grits, naples yellow 3 core, permanent yellow 3 to burnt umber 3 surface, incised decoration (see p. 151)
	P 4160	Jar	Same type as No. 2 except for fewer grits and naples yellow 2 surface (see Fig. 117); LB I
	P 4203	Jar	Same type as No. 2 except for some light grits, permanent yellow 3 core and surface; warped (see Fig. 117); LB I
3	P 4199	Bowl	Intact, many minute predominantly light grits, well made, naples yellow 2 surface, spaced ring burnishing. See Pl. 151:4 for photograph.
	P 4194	Bowl	Same type as No. 3 except for brown ocher 2 core and surface (see Fig. 118); LB I
4	P 4201	Bowl	Many predominantly light grits, brown ocher 2, traces of ring burnishing inside. See Pl. 151:2 for photograph.
	P 4200	Bowl	Same type as No. 4 but smaller and with traces of indian red 2 wash inside and over rim; LB I
5	P 4198	Lamp	Many mixed grits, roman sepia 2 core, brown ocher 2 surface
6	P 4185	Lamp	Intact, many predominantly light grits, brown ocher 3 surface. See Pl. 151:1 for photograph.
	P 4178 } P 4210 }	Lamps	Same type as No. 6 except for fewer grits and naples yellow 2 surface (see Fig. 118); LB I
7	P 4211	Lamp	Some light grits, blue-black 3 core, brown ocher 3 surface
8	P 4202	Lamp	Many light grits, naples yellow 2
9	P 4193	Jug	Intact, fine ware, few minute mixed grits, well made, naples yellow 2 surface, spaced vertical burnishing
10	P 4195	Jug	Few minute light grits, well made, blue-black 2, close vertical burnishing, pellet on double handle. See Pl. 151:12 for photograph.
11	P 4196	Jar	Many predominantly light grits, brown ocher 2
	P 4216	Jar	Same type as No. 11 (see Fig. 118); LB I
		Sherds	Hole-mouth rims and flat bases; Stages I-IV

TOMB 1145 B

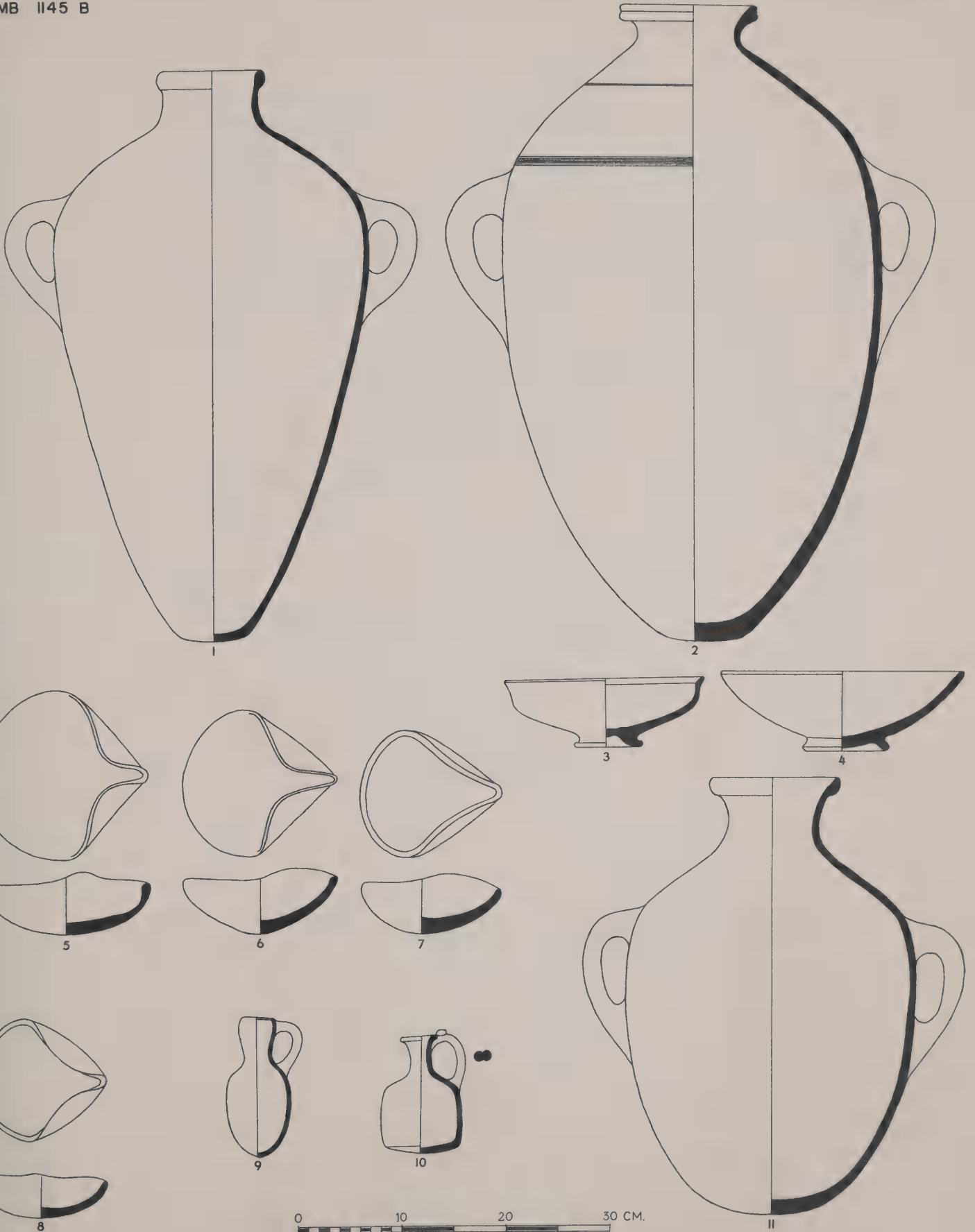

0 10 20 30 CM.

LB I POTTERY FROM TOMB 1145 B (SEE P. 95). SCALE, 1:5

No.	Field No.	Designation	Description
1	P 4248	Lamp	Some predominantly light grits, lightly fired, naples yellow 2
2	P 4244	Jar	Some light grits, well made, naples yellow 2, spaced horizontal burnishing, burnt umber 1 decoration (see Pl. 152:15 for decoration on other side and cf. Pls. 44:3 and 46:14)
3	P 4246	Jug	Intact, chiefly naples yellow 3 surface, spaced vertical burnishing
4	P 4247	Jug	Many mixed grits, burnt umber 2
5	P 4245	Bowl	Intact, some light grits, well made, burnt umber 1 surface. See Pl. 152:16 for photograph.

TOMB 1178

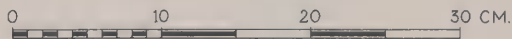
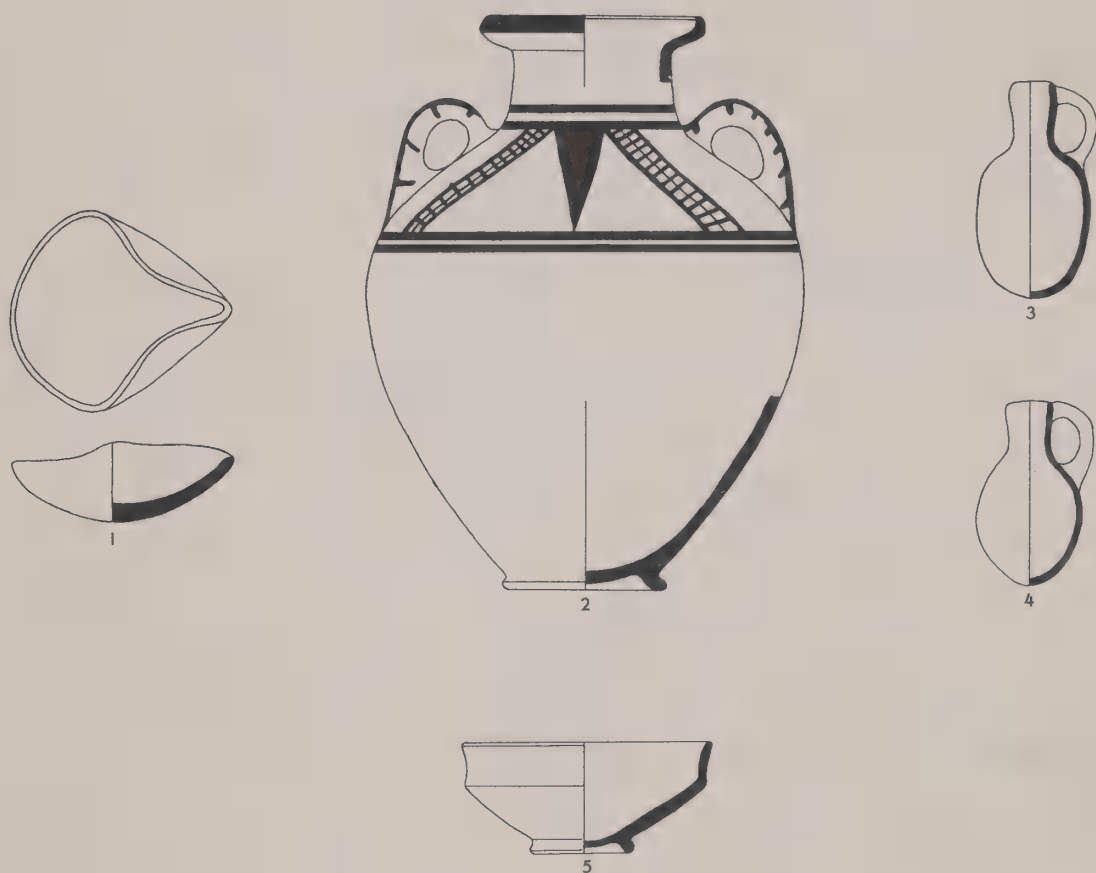

LB I POTTERY FROM TOMB 1178 (SEE PP. 99 F.). SCALE, 1:5

No.	Field No.	Designation	Description	Date
1	x 2847	Bowl	Blue-black 1 core, burnt sienna 3 surface	LB I
2	x 13	Cooking bowl	Many light grits, blue-black 3 core, burnt umber 2 surface (see p. 155)	LB II
3	x 23	Bowl	Brown ocher 3, 2 handles	LB II
4	x 14	Bowl	Brown ocher 3	LB I
	x 15-16 x 30 }	Bowls	Same type as No. 4	LB I
5	x 19	Bowl	Large grits, brown ocher 3	LB I
	x 17-18	Bowls	Same type as No. 5	LB I
6	x 20	Bowl	Blue-black 3 core, brown ocher 3 surface	LB I
7	x 31	Bowl	Charcoal gray 3 core, brown ocher 3 surface	LB II
8	x 8	Cooking bowl	Burnt sienna 3 (see p. 155)	LB II
	x 2855	Cooking bowl	Same type as No. 8	LB II
9	x 9	Cooking bowl	Blue-black 2 core, burnt sienna 3 surface (see p. 155)	LB II
10	x 12	Cooking bowl	Many light grits, blue-black 3 core, burnt umber 2 surface (see p. 155)	LB II
11	x 24	Cooking bowl	Large mixed grits, permanent brown 3 core, indian red 3 surface (see p. 155)	LB II
12	x 25	Funnel	Brown ocher 3 (see p. 155)	LB II
13	x 45	"Cup and saucer"	Charcoal gray 1 (see p. 155)	LB II
14	x 2854	Lamp	Brown ocher 3	LB I
	x 21 x 36 }	Lamps	Same type as No. 14	LB I

TOMB 4

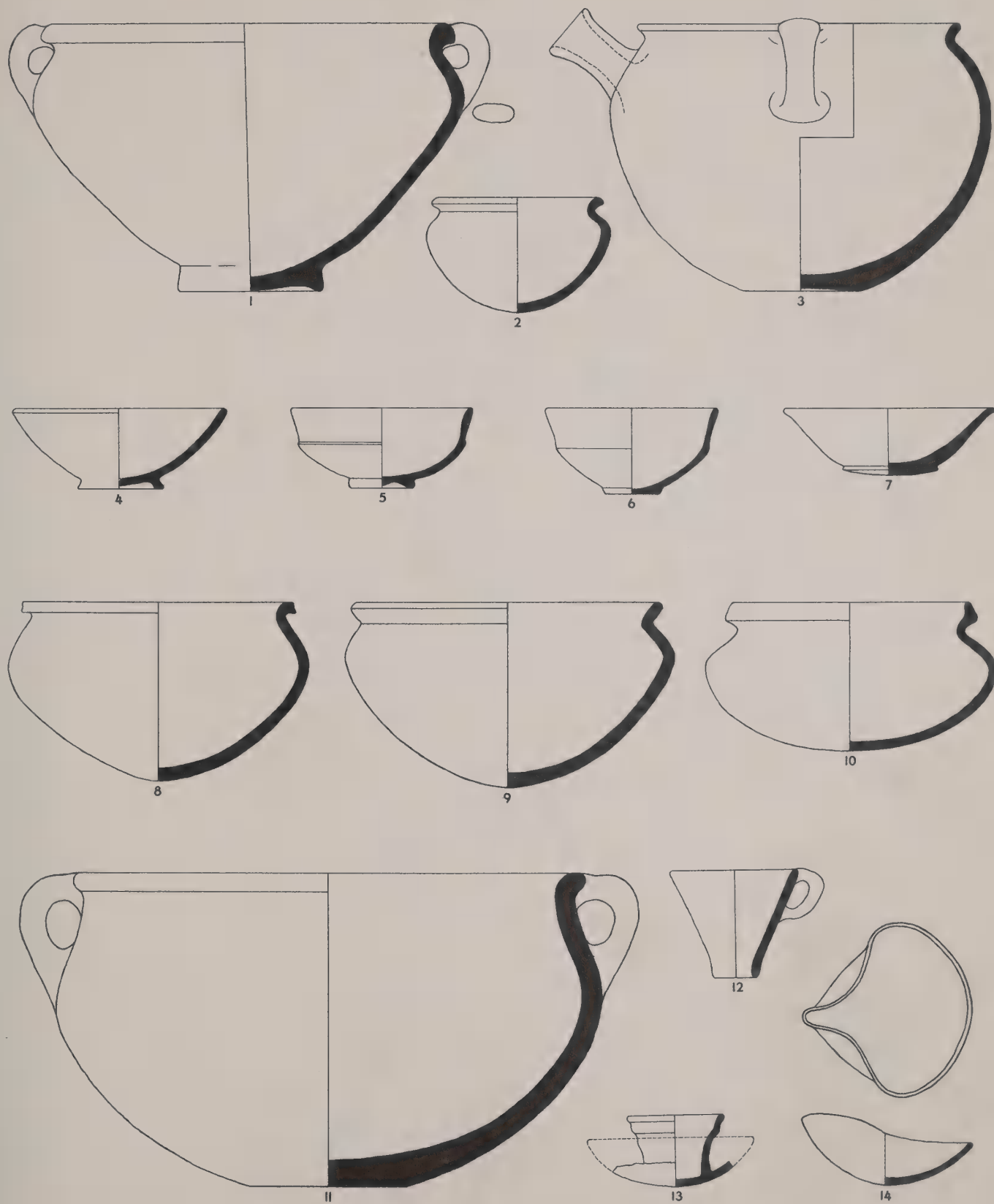

LB POTTERY FROM TOMB 4 (SEE P. 101). SCALE, 1:5

No.	Field No.	Designation	Description	Date
1	x 2849	Jug	Brown ocher 3, traces of white slip, decoration of blue-black 3 (bands), burnt sienna 3 (zigzags), and burnt umber 2 (between horizontal bands)	LB I
2	x 2848	Bilbil	Fine ware, few minute light grits, well fired, charcoal gray 3, naples yellow 3 decoration, handmade; Cypriote	LB II
3	x 5	Jug	Blue-black 2 core, burnt umber 3 surface	LB I
4	x 2851	Jug	Brown ocher 3	LB II
	x 2852-53	Jugs	Same type as No. 4	LB II
5	x 10	Jar	Permanent yellow 3	LB II
6	x 2850	Jug	Brown ocher 3 core, burnt umber 3 surface	LB I
7	x 2846	Jar	Charcoal gray 3 core, indian red 3 surface	LB II
	x 6	Jar	Same type as No. 7	LB II
8	x 7	Jar	Blue-black 3 core, burnt umber 3 surface	LB II

TOMB 4

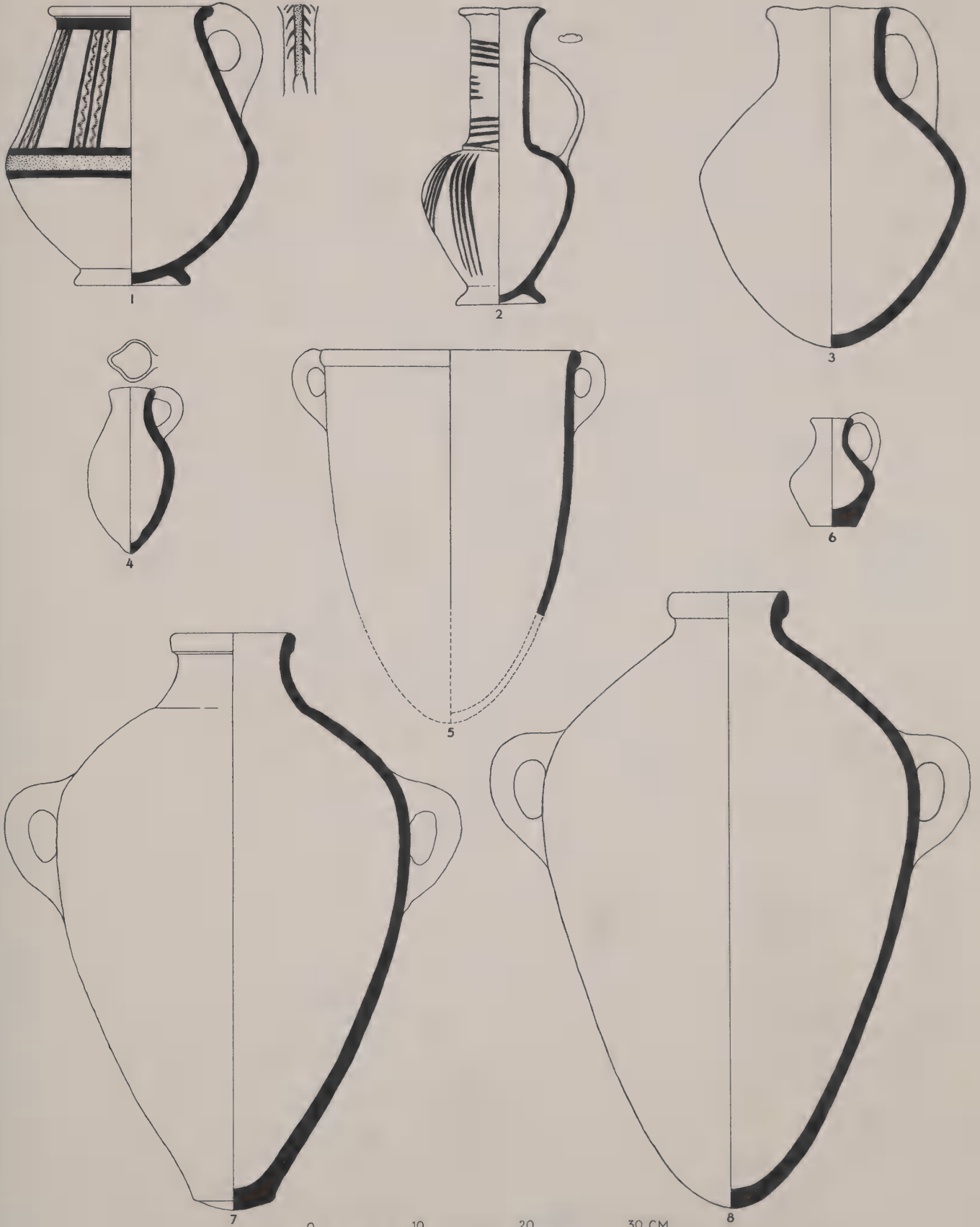

LB POTTERY FROM TOMB 4 (SEE P. 101). SCALE, 1:5

No.	Field No.	Designation	Description
TOMB 4			
1	x 2	Jar-stand	Blue-black 1 core, burnt umber 3 surface (see p. 154)
	x 50	Jar-stand	Same type as No. 1; LB II
2	x 3	Jar-stand	Blue-black 2 core, burnt umber 3 surface, handmade, coil-built (see p. 154)
	x 37	Bowl	Charcoal gray 3, handmade; EB
	x 41	Bowl	Charcoal gray 1, light red slip inside and over shoulder, scraped surface; date unknown
	x 44	Bowl	Same type as Pl. 32:22; LB II
	x 48	Milk bowl	Same type as Pl. 62:9; LB II
	x 46	Bilbil	Same type as No. 7 below; LB II
		Sherds	EB
TOMB 8			
3	x 2859	Milk bowl	Fine ware, small mixed grits, well fired, charcoal gray 3 core, blue-black 3 surface, handmade; Cypriote (see p. 158). See Pl. 153:13 for photograph.
4	x 2858	Bowl	Small light grits, burnt umber 3 core, brown ocher 3 surface
5	x 2860	Bowl	Permanent brown 3. See Pl. 153:12 for photograph.
6	x 3	Jug	Permanent yellow 3
7	x 2861	Bilbil	Indian red 1 core, brown ocher 3 surface, naples yellow 3 decoration, handmade; Cypriote (see p. 158). See Pl. 153:15 for photograph.
8	x 5	Bilbil	Fine ware, small mixed grits, well fired, blue-black 2 core, burnt umber 3 and blue-black 2 surface, naples yellow 3 decoration, handmade; Cypriote (see p. 158). See Pl. 153:16 for photograph.
9	x 2862	Flask	Fine ware, small mixed grits, light red 3, permanent yellow 3 slip, lustrous indian red 3 decoration; Mycenaean. See Pl. 153:14 for photograph.
10	x 2	Jar	Charcoal gray 3 core, brown ocher 3 surface
	x 1	Jar	Same type as No. 10; LB II
11	x 9	Jar	Permanent brown 3
	x 8	Jug	Same type as Pl. 25:12; MB II

TOMB 4

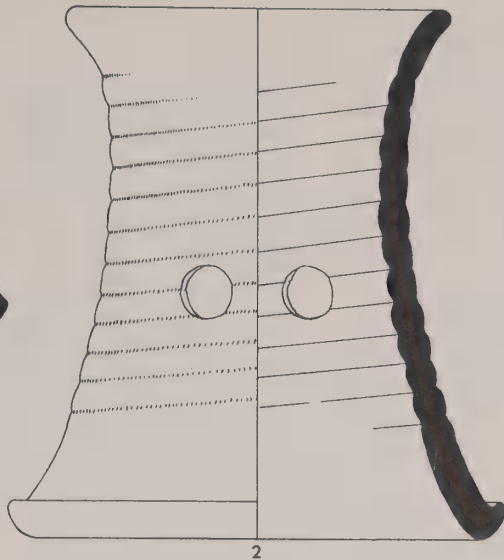

TOMB 8

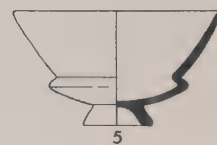
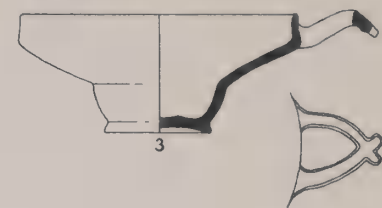

TOMB 8

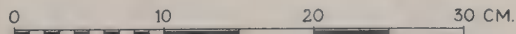
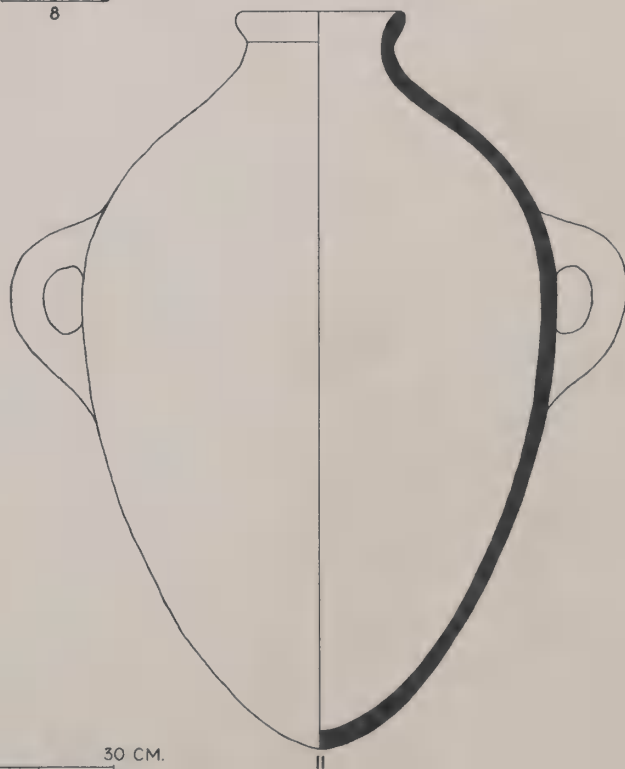
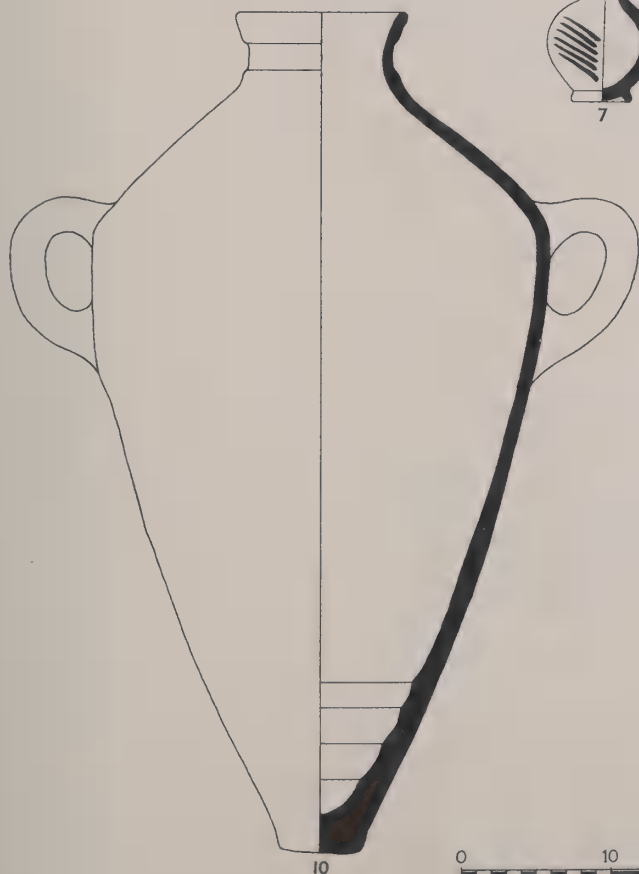
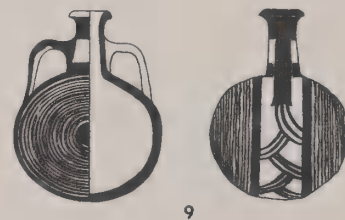
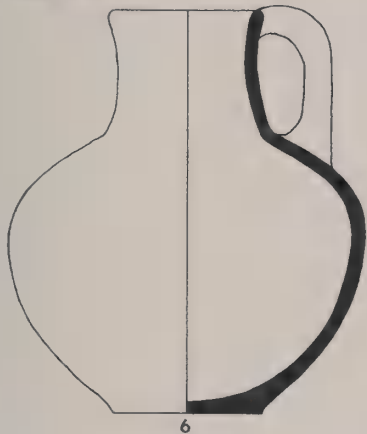

LB II POTTERY (No. 5 MB II) FROM TOMBS 4 AND 8 (SEE P. 101). SCALE, 1:5

No.	Field No.	Designation	Description
TOMB 25			
1	x 3	Jug	Brown ocher 3
	x 4	Jug	Same type as No. 1; LB II
2	x 2	Bowl	Charcoal gray 3 core, indian red 3 surface
3	x 7	Bowl	Charcoal gray 1 core, indian red 3 surface
	x 8	Bowl	Same type as No. 3; LB II
4	x 5	Bowl	Permanent brown 3
	x 6	Bowl	Same type as No. 4; LB II
5	x 14	Bowl	Brown ocher 3
	x 15	Jar	Same type as Pl. 56:10; LB II
	x 9	"Cup and saucer"	Same type as Pl. 58:18; LB II
TOMB 26			
6	x 458	Jug	Brown ocher 1
7	x 3174	Jug	Brown ocher 3 (see p. 155)
8	x 3171	Chalice	Charcoal gray 3 core, burnt umber 3 surface, indian red 2 slip, irregular burnishing (see p. 154). See Pl. 154:11 for photograph.
9	x 60	Jar	Blue-black 3 core, permanent brown 1 surface (see p. 155)
	x 25 } x 65 }	Jars	Same type as No. 9; LB II
10	x 3178	Jar	Burnt umber 3 (see p. 155)
11	x 80	Jar	Permanent brown 3 core, indian red 3 surface, burnt umber 3 decoration (see p. 155)
12	x 93	Jar	Charcoal gray 3 core, brown ocher 2 surface

TOMB 25

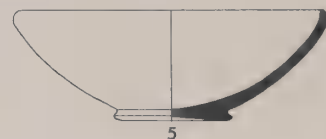
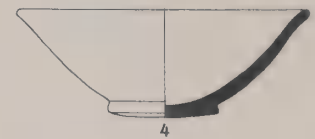
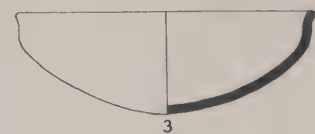
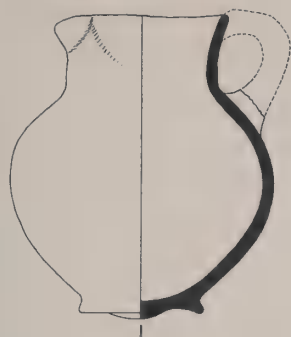

TOMB 26

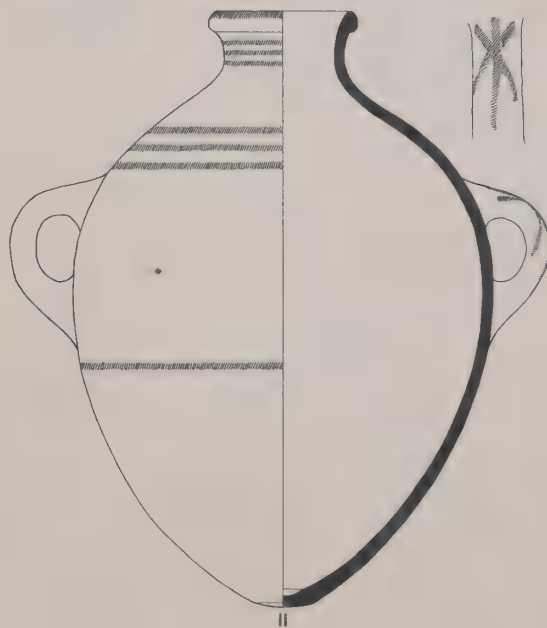
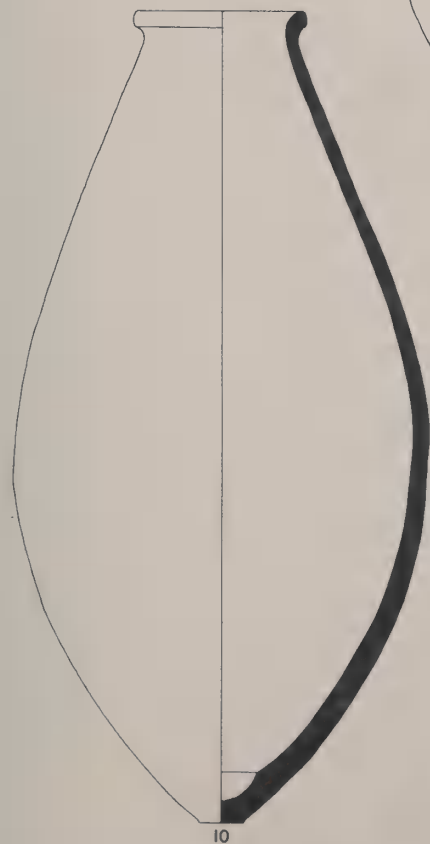
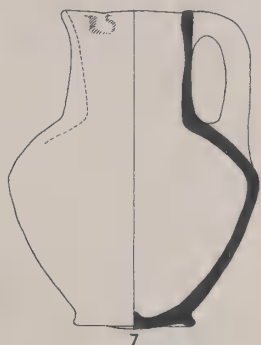
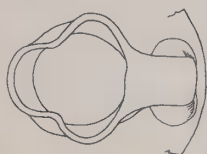

LB II POTTERY FROM TOMBS 25-26 (SEE P. 103). SCALE, 1:5

No.	Field No.	Designation	Description	Date
TOMB 26				
1	x 3168	Bowl	Poorly made, brown ocher 3	LB II
	x 461 x 3167 x 3169	Bowls	Same type as No. 1	LB II
2	x 11	Bowl	Brown ocher 3 core, indian red 3 surface	LB II
3	451	Bowl	Permanent brown 3, indian red 2 decoration	LB II
	x 462	Bowl	Same type as No. 3	LB II
4	x 39	Bowl	Permanent brown 3 core, permanent yellow 1 surface	LB II
	x 35 x 40	Bowls	Same type as No. 4	LB II
	x 33	Bowl	Permanent brown 1 core, light red 1 surface	LB II
	x 36-38	Bowls	Same type as No. 6	LB II
	x 61	Bowl	Large mixed grits, charcoal gray 1	LB II
	x 66	Bowl	Same type as Pl. 59:2	LB I
	x 81	Bowl	Same type as Pl. 59:5	LB II
	x 3188-89	Bowls	Same type as Pl. 59:3	LB II
	x 3183-87	Lamps	Same type as Pl. 123:11	LB II
TOMB 26 A				
5	x 3198	Jar	Brown ocher 3, scraped sides, 3 handles (see p. 155). See Pl. 154:16 for photograph.	LB II
6	x 3196	Bowl	Brown ocher 3	LB II
	x 3191-95 x 3201-3	Bowls	Same type as No. 6	LB II
7	x 3200	Bowl	Brown ocher 3	LB I
8	x 3228	Bowl	Charcoal gray 3 core, brown ocher 3 surface	LB I
9	x 3220	Bowl	Poorly made, brown ocher 3	LB I
	x 3219 x 3221-24 x 3226	Bowls	Same type as No. 9	LB I
10	x 3229	Bowl	Brown ocher 3. See Pl. 154:22 for photograph.	LB I
11	x 3199	Cooking bowl	Poorly made, brown ocher 1	LB II?
12	x 3231	Stopper	Poorly made, brown ocher 2	LB II?
13	x 3230	Cup	Brown ocher 3. See Pl. 154:18 for photograph.	LB I
14	x 3209	"Cup and saucer"	Brown ocher 3 (see p. 155)	LB II
	x 3210-11	"Cups and saucers"	Same type as No. 14	LB II
TOMB 26 B				
15	x 3298	Jug	Brown ocher 3, burnished	LB I
	x 74 x 92-93 x 106 x 3299-3323	Jugs	Same type as No. 15	LB I
16	x 3297	Jug	Brown ocher 3, burnished	LB I
17	x 3276	"Cup and saucer"	Poorly made, blue-black 3 core, brown ocher 3 surface (see p. 155)	LB II
18	x 3330	"Cup and saucer"	Charcoal gray 3 core, brown ocher 3 surface, indian red 3 wash (see p. 155)	LB II
19	x 3275	Jar-stand	Poorly made, permanent brown 3 (see p. 154)	LB II
20	x 3237	Jug	Brown ocher 3, burnt sienna 3 decoration	LB I
	x 22 x 118 x 120 x 3238-52 x 3293-96 x 3331-32 x 03325-30	Jugs	Same type as No. 20	LB I
21	x 3288	Cup	Permanent brown 3	LB I
22	x 3232	Bowl	Charcoal gray 3 core, burnt umber 2 surface	LB I
	x 6 x 3233-36	Bowls	Same type as No. 22	LB I
23	x 3286	Bowl	Poorly made, brown ocher 3	LB I
	x 3287	Bowl	Same type as No. 23	LB I
24	x 3338	Chalice	Light grits, permanent brown 3, indian red 3 wash, irregular burnishing, roman sepia 3 decoration (see p. 152). See Pl. 155:3 for photograph.	LB I

TOMB 26

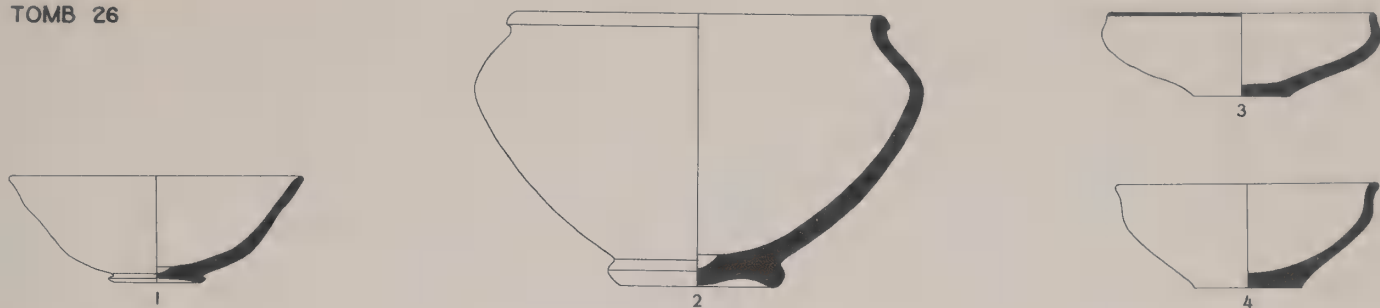

TOMB 26 A

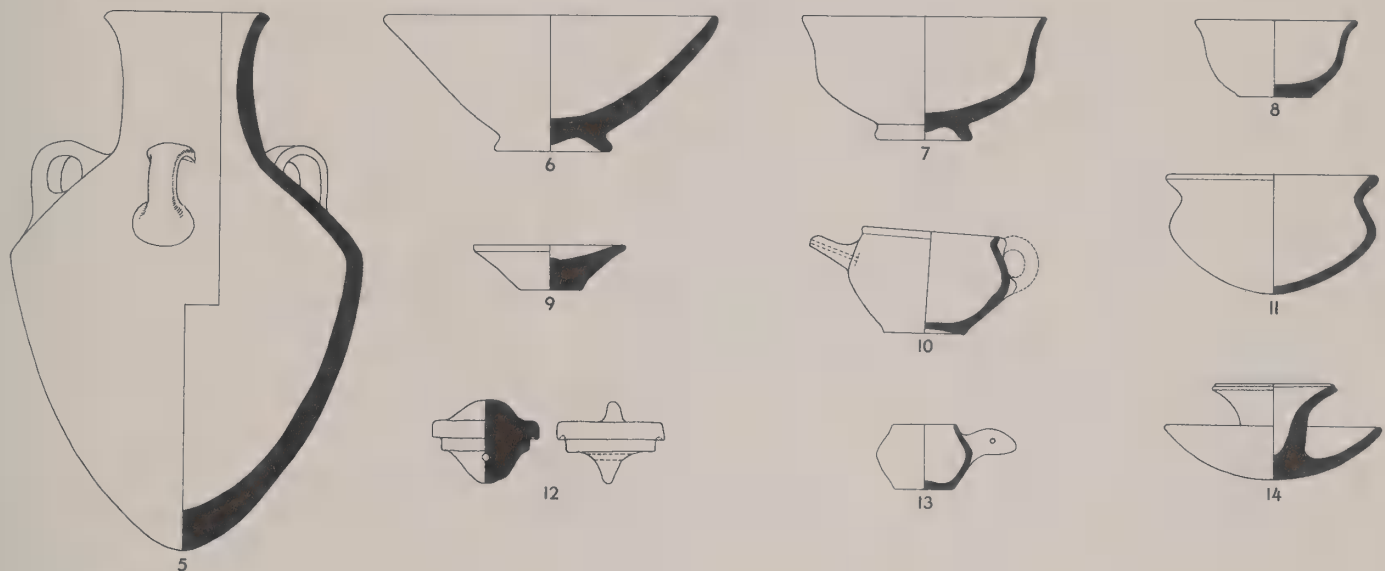

TOMB 26 B



LB POTTERY FROM TOMB 26 (SEE P. 103). SCALE, 1:5

No.	Field No	Designation	Description	Date
TOMB 26 B				
1	x 128	Bowl	Brown ocher 3 core, indian red 3 surface	LB I
2	x 127	Bowl	Charcoal gray 3 core, indian red 3 surface	LB I
	x 3280-84	Bowls	Same type as No. 2	LB I
3	x 3253	Bowl	Poorly made, brown ocher 3	LB II
	x 3254-55	Bowls	Same type as No. 3	LB II
4	x 3279	Bowl	Fine mixed grits, poorly made, permanent brown 3	LB II
	x 3285	Bowl	Same type as No. 4	LB II
5	x 3278	Bowl	Permanent brown 3	LB II
6	x 3335	Bowl	Poorly made, blue-black 3 core, brown ocher 1 surface. See Pl. 155:1 for photograph.	LB I
7	x 03336	Bowl	Large light grits, poorly made, charcoal gray 3 core, burnt umber 3 surface, hole in base	LB II?
TOMB 36 B				
8	x 2936	Bowl	Permanent brown 3, naples yellow 3 slip, burnished, faded burnt umber 3 and roman sepia 1 decoration	LB II
9	x 18	Bowl	Brown ocher 3	LB II
10	x 10	Bowl	Permanent brown 3	LB II
	x 523 a	Bowl	Same type as No. 10	LB II
11	x 524	Jug	Blue-black 3 core, brown ocher 3 surface	LB II
12	x 523	Bilbil	Fine ware, fine grits, well fired, burnt umber 3 core, burnt umber 3 and blue-black 3 surface, naples yellow 3 decoration, handmade; Cypriote	LB II
	x 525-26	Lamps Sherds	Same type as Pl. 66:21	LB II LB I
TOMB 40				
13	x 0799	Chalice	Charcoal gray 3 core, brown ocher 3 surface (see p. 154); found with No. 17. See Pl. 156:9 for photograph.	LB II
14	x 799	Cover	Charcoal gray 3 core, brown ocher 3 surface	LB II
15	x 0799 c	Jug	Burnt umber 3 core, permanent yellow 3 surface, vertical shaving, handmade (see p. 155). See Pl. 156:8 for photograph.	LB II
16	x 13	"Cup and saucer"	Brown ocher 3 (see p. 155)	LB II
17	x 0799 a	Bowl	Blue-black 3 core, brown ocher 3 surface; found with No. 13. See Pl. 156:9 for photograph.	LB II
		Sherds		LB I
TOMB 48				
18	x 1	Jar	Permanent brown 3 core, permanent yellow 3 surface (see p. 155)	LB II

TOMB 26 B

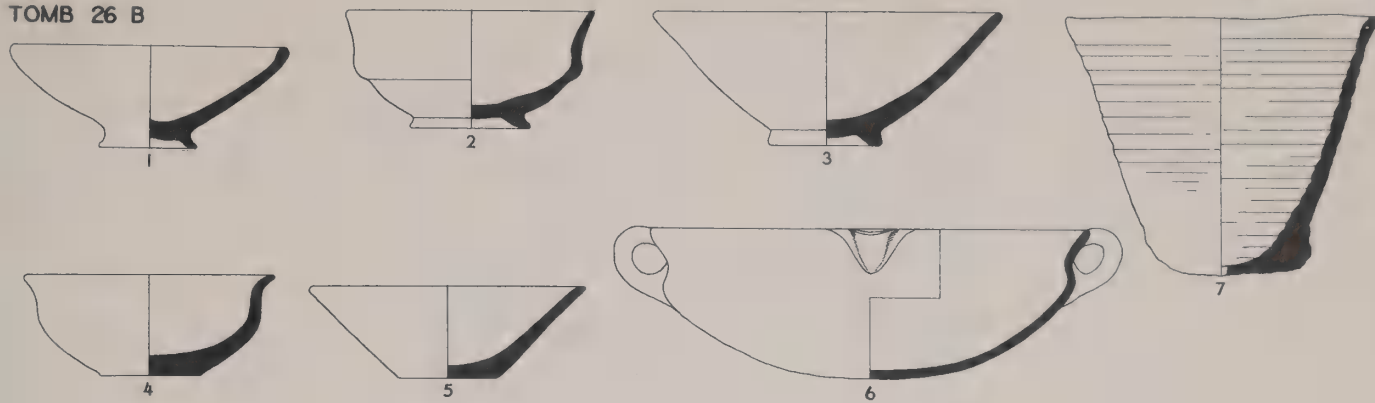

TOMB 36 B

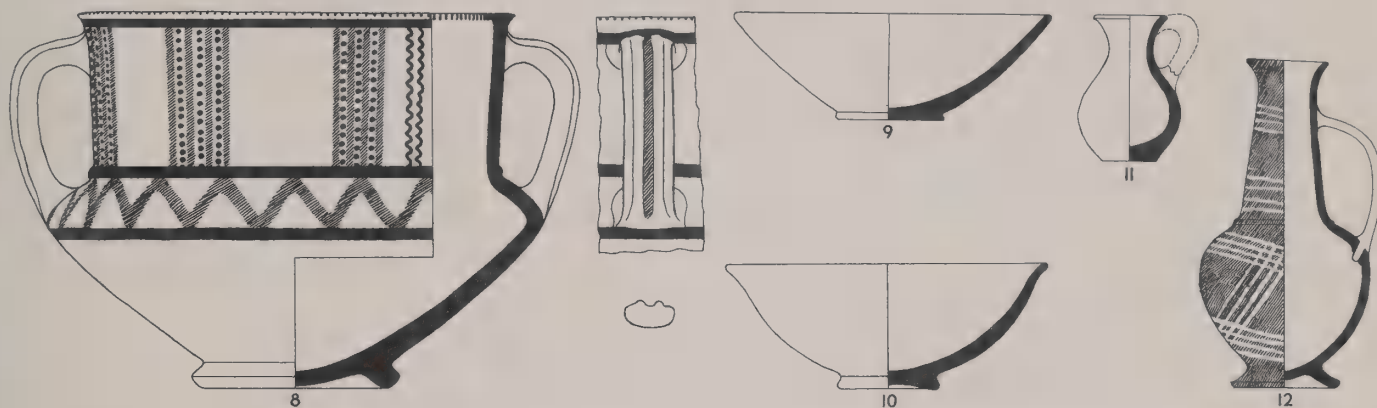

TOMB 40

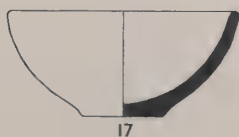
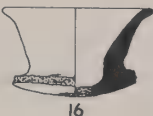
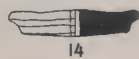
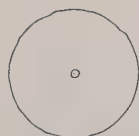
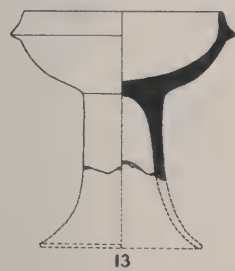

TOMB 48

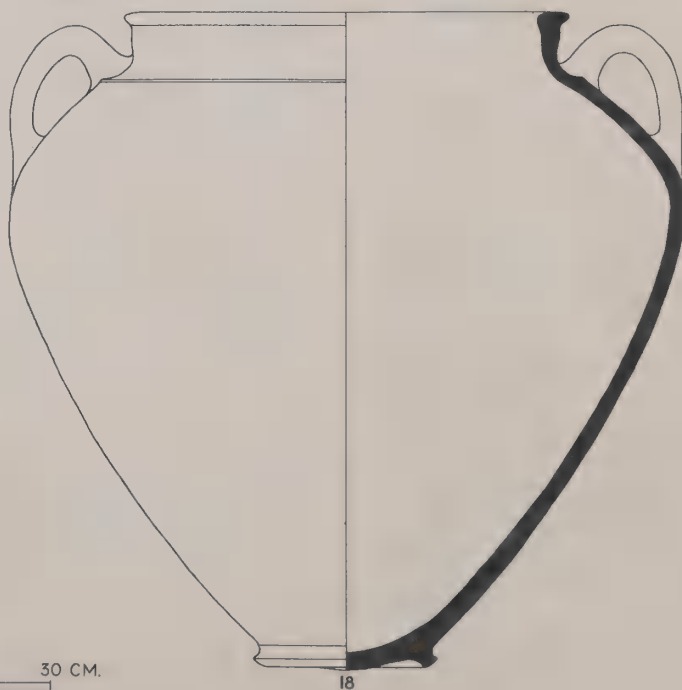

No.	Field No.	Designation	Description	Date*
TOMB 48				
1	x 01357	Milk bowl	Charcoal gray 3 core, burnt umber 3 surface, naples yellow 1 slip, bister 3 decoration, handmade; Cypriote	LB II
2	x 01359 a	Bowl	Permanent brown 3	LB II
	x 1358-59 x 01358-59 }	Bowls	Same type as No. 2	LB II
3	x 1352	Funnel	Large light grits, poorly made, poorly fired, permanent brown 3, hole in base. See Pl. 156:17 for photograph.	LB II
4	x 1355	Chalice	Permanent brown 3 core, burnt umber 3 surface (see p. 154)	LB II
5	x 1356	Chalice	Permanent brown 3, burnt umber 3 slip, roman sepia 1 decoration (see p. 155)	LB II
TOMB 63				
6	P 116	Bowl	Fine ware, few minute dark grits, well made, well fired, permanent brown 3, light red 1 wash inside and over rim, fairly close horizontal burnishing outside, crisscross burnishing inside (cf. <i>OIP</i> XLII, Pl. 28, No. 93 b)	E-MI
7	3718	Bowl	Same as No. 6 except for light red 2 wash (cf. <i>OIP</i> XLII, Pl. 28, No. 103)	E-MI
8	3722	Bowl	D. .25, permanent brown 3 core, near brown ocher 3 surface, spaced horizontal burnishing (cf. <i>OIP</i> XLII, Pl. 28, No. 102)	E-MI
9	P 117	Bowl	D. .20, fine ware, few minute light grits, very well made, well fired, brown ocher 1, indian red 1 wash, close horizontal burnishing, incised decoration (cf. <i>OIP</i> XLII, Pl. 25, No. 57)	E-MI
10	5519	Bowl	D. .23; same as No. 9 except for wash inside and over rim only	E-MI
11	3669	Bowl	D. .29, coarse ware, poorly made, well fired, charcoal gray 3 core, roman sepia 3 surface, light red 2 wash inside and over rim	MI
12	5520	Bowl	Fine ware, few minute dark grits, very well made, burnt umber 3 core, indian red 3 wash inside and near burnt umber 3 outside, close horizontal burnishing, indian red 3 and incised decoration (cf. <i>OIP</i> XLII, Pl. 25, No. 57)	E-MI
13	3660	Bowl	D. .34, many mixed grits, poorly made, charcoal gray 3 core, naples yellow 1 surface	MI
14	3659	Bowl	Coarse ware, many light grits, well fired, charcoal gray 3 core, brown ocher 2 surface	?
15	3680	Bowl	Many mixed grits, poorly made, well fired, charcoal gray 3 core, near burnt umber 3 surface	LB II
16	3666	Bowl	Fine ware, many large mixed grits, poorly made, well fired, blue-black 3 core, near vandyke brown 3 surface	LB II
17	P 54	Jar	Permanent brown 3 core, near roman sepia 3 surface	MI
	P 34-35 } P 51-53 } P 55 }	Jars	Same type as No. 17	MI
18	3670	Jar	Shoulder d. .285; same as No. 17	MI
19	3674	Jar	Rim d. .112, some large mixed grits, chiefly charcoal gray 3 core, near naples yellow 1 surface	MI
20	3678	Jar	Rim d. .130, many large mixed grits, permanent brown 3 core, naples yellow 1 and light red 1 surface	MI
21	3683	Jar	Many mixed grits, permanent brown 3 core, light red 3 surface, indian red 3 decoration	LB II
22	3695	Jug	Many light grits, charcoal gray 3 core, light red 3 surface, indian red 3 decoration	LB II
23	3724	Jug	Brown ocher 3	EI
24	3725	Jug	Many mixed grits, permanent brown 3 core, light red 3 wash (cf. <i>OIP</i> XLII, Pl. 1, No. 17)	MI
25	3723	Cover	Many mixed grits, poorly made, permanent brown 3 core, light red 3 inside surface, light red 1 wash outside, spaced irregular burnishing	MI
26	3691	Spout	Some minute mixed grits, burnt umber 3 core, light red 2 wash, close vertical burnishing; intrusive	Stages IV-VII. Col. 23
27	3692	?	Fine ware, few minute dark grits, well made, well fired, permanent brown 3 core, brown ocher 1 wash, close vertical burnishing; intrusive	Stages IV-VII?
TOMB 63 A				
28	3699	Cooking bowl	D. .26, many light grits, well fired, blue-black 3 core, brown ocher 2 surface, blackened by fire	?
29	3710	Cooking bowl	Rim d. .36, many mixed grits, vandyke brown 3 core, near brown ocher 2 surface, blackened by fire	?
30	P 60	Chalice	Well fired, charcoal gray 3 core, light red 3 surface, indian red 3 decoration (see p. 154)	LB II
31	3701	Jug	Fine ware, some minute mixed grits, blue-black 3 core, darker surface, close vertical burnishing (cf. <i>OIP</i> XLII, Pl. 5, Nos. 124-27)	E-MI
		Jugs (9)	Same type as No. 31	E-MI
TOMB 63 B				
32	3750	Bowl	Few mixed grits, permanent brown 3 core, near naples yellow 1 surface (cf. <i>OIP</i> XLII, Pl. 30, No. 123)	EI II
33	3765	Bowl	Few mixed grits, charcoal gray 3 core, light red 3 surface	LB II
34	P 77	Bowl	Many large mixed grits, poorly made, well fired, charcoal gray 3 core, light red 3 surface	EI
35	3697	Bowl	Well fired, charcoal gray 3 core, near light red 3 surface, indian red 3 decoration	LB II
36	P 59	Chalice	Same as No. 30	LB II
37	3775	Jar	Lightly fired, chiefly burnt umber 3 core, near vandyke brown 3 surface, incised decoration, handmade; intrusive	Stages I-III. Col. 12 C
38	3776	Jar	Well fired, permanent brown 3 core, light red 3 surface, indian red 3 decoration	LB II
39	3741	Jug	Many large mixed grits, well fired, roman sepia 3 core, light red 3 and roman sepia 3 surface, light red 1 decoration	LB II
	P 78	Bowl	Same shape as Pl. 62:30, many mixed grits, burnt umber 3 core and surface	EI I
	3754	Jar	Same shape as Pl. 61:3, some large mixed grits, charcoal gray 3 core, near brown ocher 3 surface	LB II
	3726	Lamp	Same shape as Pl. 54:14, many minute dark grits, charcoal gray 3 core, near brown ocher 3 surface, lip blackened by fire	LB

\* "Stages" do not date a given piece but indicate the duration of its type. See SAOC No. 10 pp. 52-65 and chart.

TOMB 48

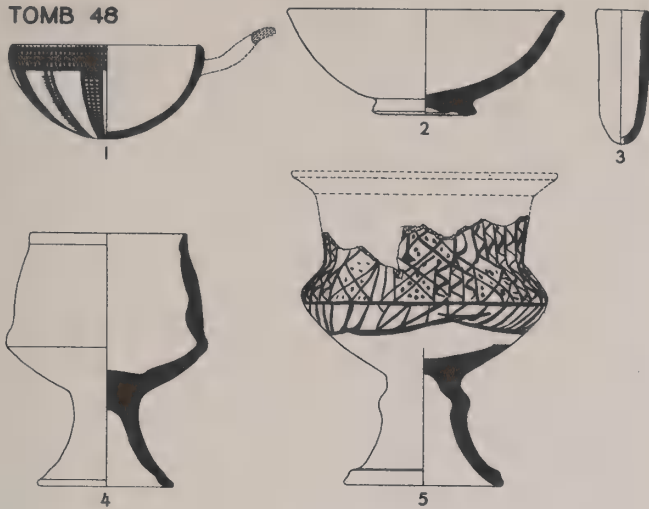

TOMB 63

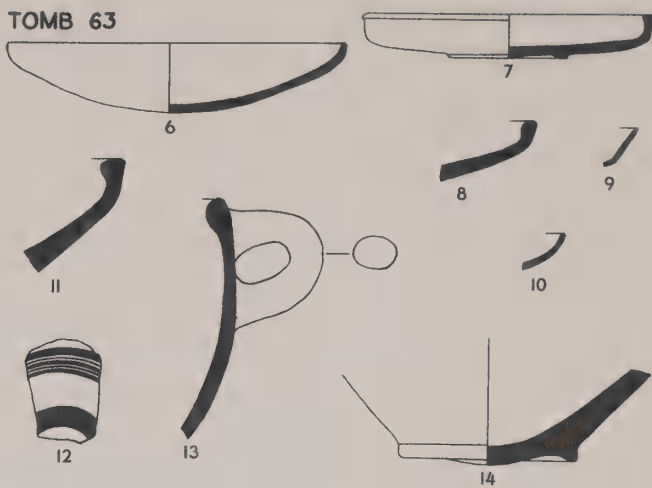

TOMB 63

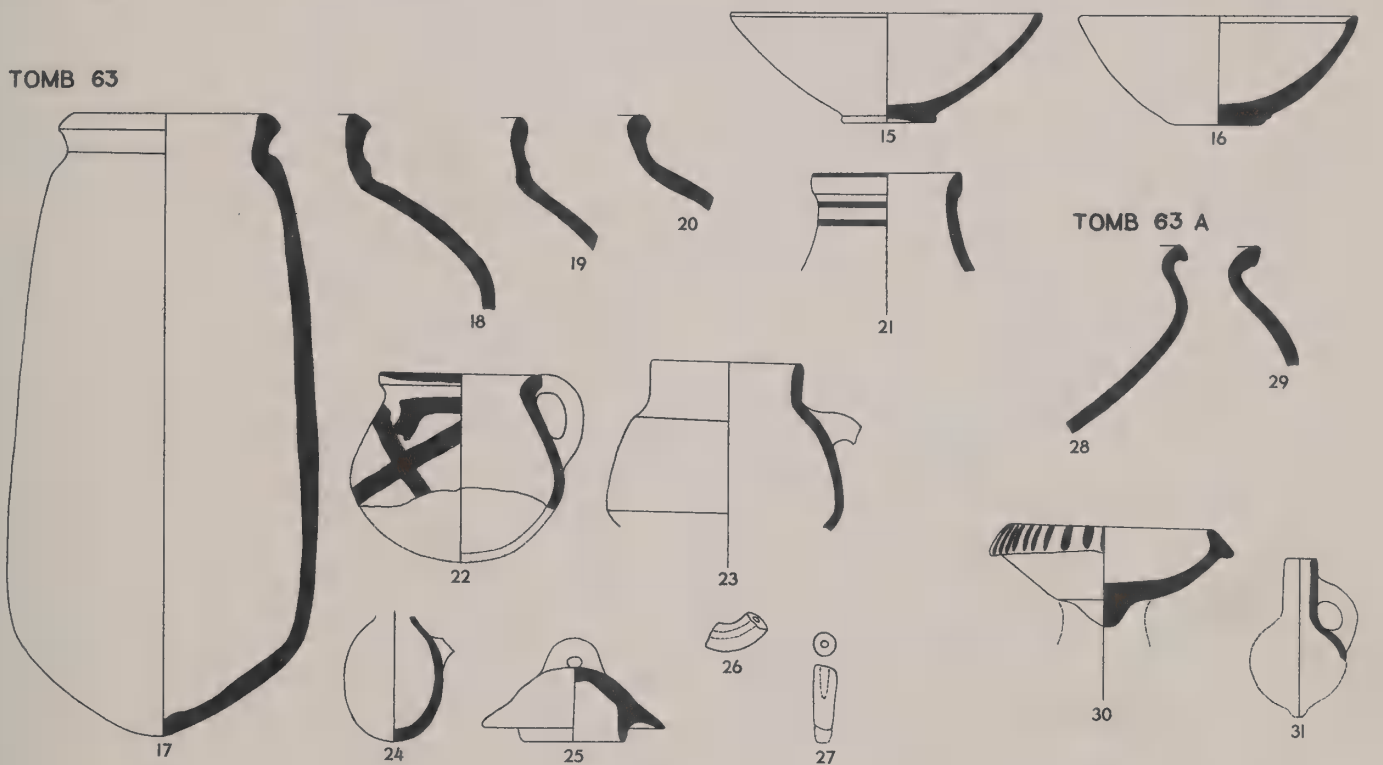

TOMB 63 A

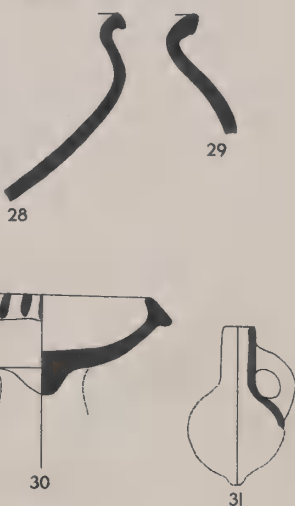

TOMB 63 B

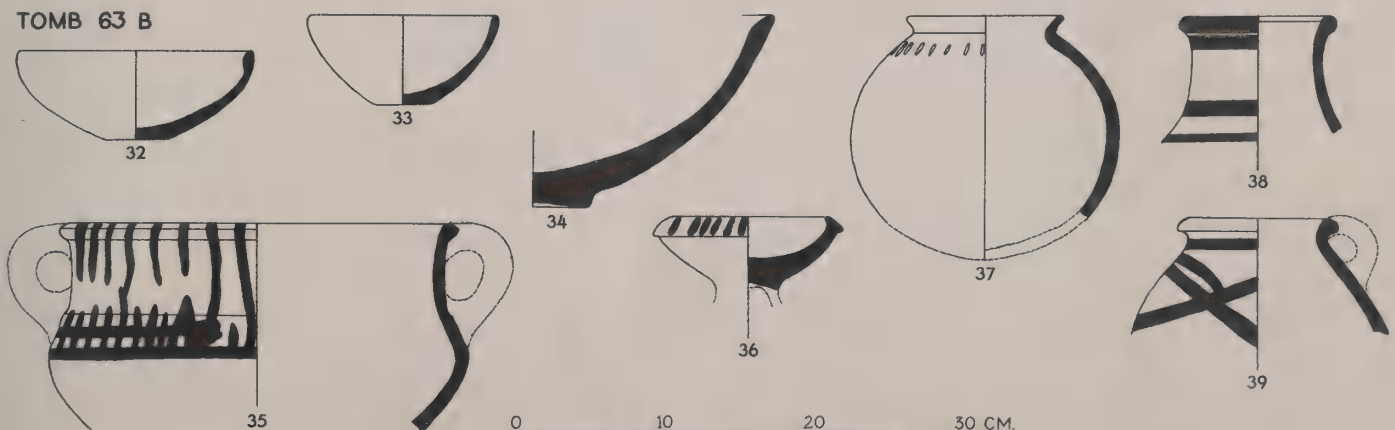

POTTERY FROM TOMBS 48 AND 63 (SEE PP. 106 AND 108-11). SCALE, 1:5

No.	Field No.	Designation	Description	Date
TOMB 63 C				
1	3805	Bowl	Many large mixed grits, well fired, warm sepia 3 core, burnt umber 3 surface	?
2	3802	Bowl	Many mixed grits, chiefly charcoal gray 3 core, burnt umber 3 surface	?
3	P 112	Jar	Many large light grits, well fired, burnt umber 3	LB II
4	3801	Jar	D. .31, fine ware, many light grits, heavily fired, permanent brown 3 core, burnt umber 3 surface, indian red 3 decoration	LB II
5	P 113	Jar	Many minute mixed grits, black lead 1 core, burnt umber 3 surface	LB II
	P 154	Jar	Well fired specimen like No. 5 except for burnt umber 3 core	LB II
6	3788	Jug	Few mixed grits, poorly made, permanent brown 3 core, light red 1 surface, close vertical burnishing	MI
7	3803	Jar	Many minute dark grits, heavily fired, charcoal gray 3 core, warm sepia 3 surface, pottery mark	LB II
8	3790	Jar	Many light grits, well fired, blue-black 3 core, burnt umber 3 surface	LB II
TOMB 63 D				
9	3816	Bowl	Poorly made, burnt umber 2 core, near burnt umber 3 surface	LB II
10	P 79	Bowl	Permanent brown 3 core, indian red 2 wash, traces of burnishing	EI II
11	3813	Bowl	Fine ware, permanent brown 3 core, light red 3 to burnt umber 3 wash, traces of burnishing	EI II
12	P 114	Bowl	Many large light grits, poorly made, near burnt umber 3	LB II
13	3809	Bowl	Many mixed grits, charcoal gray 3 core, indian red 3 wash, close vertical burnishing inside, naples yellow 1 decoration	EI II
14	3806	Bowl	Charcoal gray 3 core, near brown ocher 3 surface	EI I
TOMB 63 E				
15	P 39	Bowl	Poorly made, charcoal gray 3 core, burnt umber 3 surface	LB II
16	P 38	Bowl	Same as No. 15	LB II
17	P 57	Bowl	Poorly made, burnt umber 3	LB II
18	3830	Bowl	Poorly made, burnt umber 3	LB II

TOMB 63 C

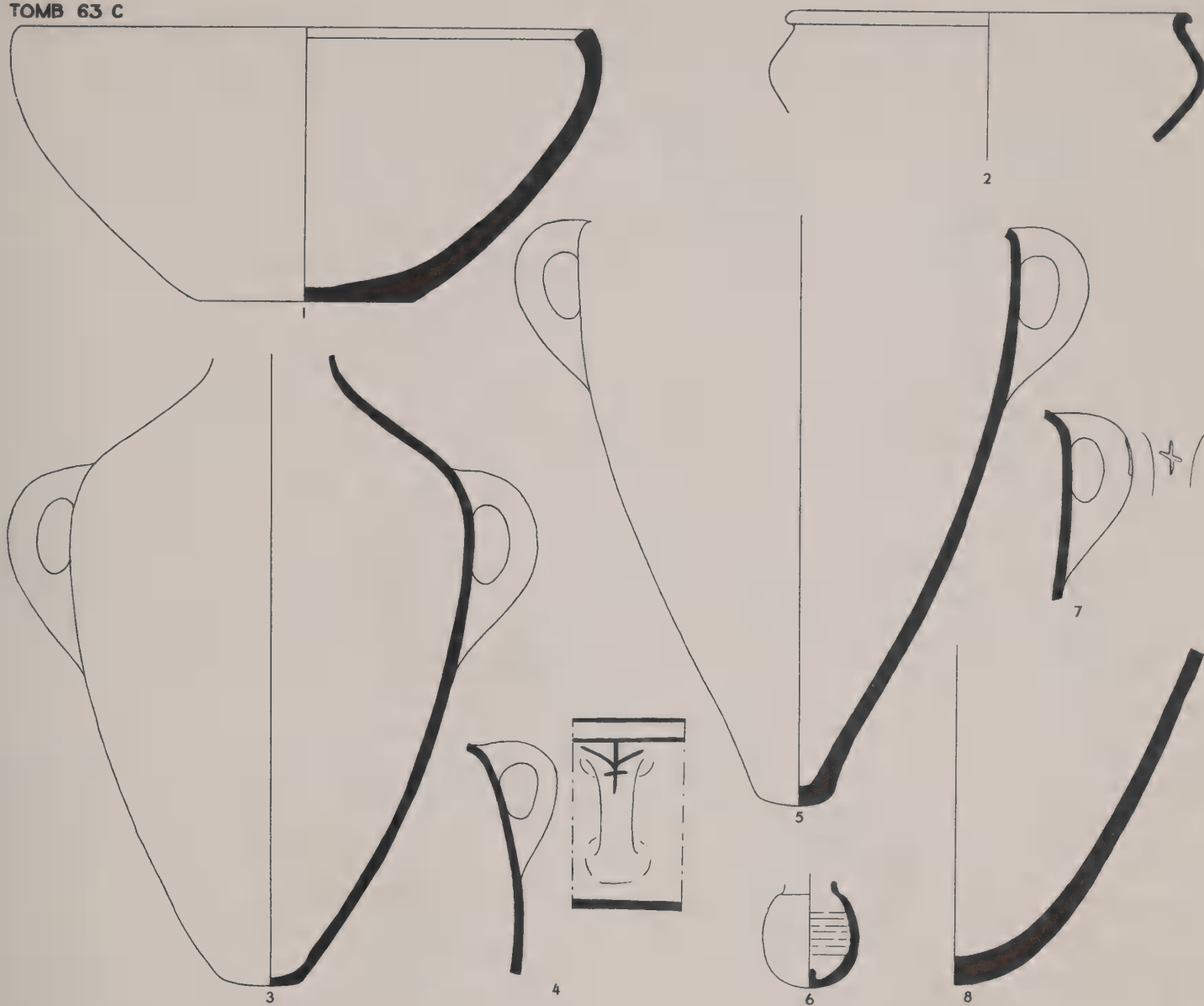

TOMB 63 D

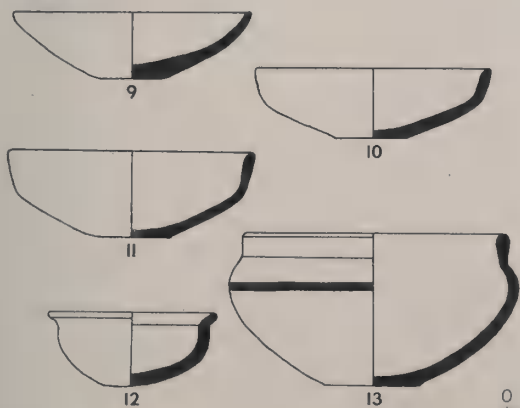

TOMB 63 E

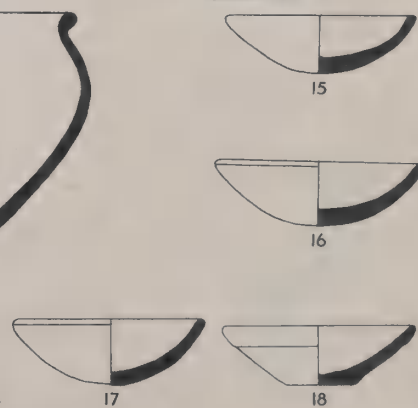

POTTERY FROM TOMB 63 (SEE PP. 108-11). SCALE, 1:5

No.	Field No.	Designation	Description	Date
TOMB 63 E				
1	3823	Bowl	Permanent brown 3 core, near naples yellow 1 surface, light red 3 wash inside and over rim, blackened by fire	EI II
2	3837	Bowl	Poorly made, charcoal gray 3 core, burnt umber 3 surface	LB II
3	3819	Bowl	Poorly made, burnt umber 3	LB II
4	P 29	Bowl	Intact; same as No. 2	LB II
5	P 30	Bowl	Poorly made, permanent brown 3 core, burnt umber 3 surface	LB II
6	3841	Bowl	Charcoal gray 3 core, burnt umber 3 surface; part of No. 7	LB II
7	3846	Bowl	Part of No. 6	LB II
8	P 56	Bowl	Chiefly burnt umber 3	LB II
9	P 26	Milk bowl	Fine ware, many minute mixed grits, burnt umber 2 core, warm sepia 3 surface, burnt umber 1 decoration, handmade; Cypriote. See Pl. 158:6 for photograph.	LB II
10	3824	Chalice	Chiefly permanent brown 3 core, burnt umber 3 surface	EI
11	P 37	Jug	Intact; same as No. 10	LB II
12	P 36	Jug	Intact; same as No. 10	LB II
13	P 32	Jug	Burnt umber 3	LB II
14	P 33	Jug	Fine ware, some minute mixed grits, well made, well fired, charcoal gray 3 and burnt umber 3 core, indian red 3 and burnt umber 3 surface, close vertical burnishing on neck, horizontal burnishing on body (cf. <i>OIP</i> XLII, Pl. 5, Nos. 124-27)	E-MI
15	3825	Jug	Fine ware, some minute mixed grits, blue-black 1, close horizontal burnishing	E-MI
16	P 31	Jug	Many mixed grits, near burnt umber 3 core, lighter surface, traces of indian red 3 wash	LB II
17	3821	Jug	Many large mixed grits, well fired, burnt umber 3 core, chiefly light red 3 surface, spaced horizontal burnishing, indian red 3 decoration	LB II
18	P 58	Jar	Many mixed grits, charcoal gray 3 core, chiefly near warm sepia 3 surface, spaced horizontal burnishing, purple madder 3 decoration	LB II
19	P 40	Jar	Many large mixed grits, poorly made, permanent brown 3 core, burnt umber 3 surface, naples yellow 1 decoration	LB II
20	P 27	Stirrup cup	Fine ware, few large grits, well made, heavily fired, brown ocher 3 core, naples yellow 3 slip, close horizontal burnishing, burnt umber 1 to 3 decoration; Mycenaean (see p. 157). See Pl. 158:5 for photograph.	LB II (see p. 111)
21	P 28	Stirrup cup	Same as No. 20	LB II (see p. 111)
TOMB 63 F				
22	P 63	Cooking bowl	Complete, many light grits, well made, lightly fired, charcoal gray 3 core, rubens madder 2 surface	EI I
23	3907	Bowl	D. .220, some light grits, well fired, burnt umber 3 core, light red 1 wash and close horizontal burnishing inside, near indian red 3 wash with darker latticed hatched decoration outside	EI I
24	P 155	Bowl	Some large mixed grits, charcoal gray 3 core, burnt umber 3 surface	EI I
25	P 149	Bowl	Many mixed grits, well made, near burnt umber 3, thumb handle	LB II
26	P 42	Bowl	Intact; same as No. 32; blackened by fire inside	LB II
27	3900	Bowl	Permanent brown 3 core, warm sepia 3 surface, light red 1 wash inside and over rim, spaced horizontal burnishing	MI
28	3865	Bowl	Many large grits, poorly made, well fired, permanent brown 3 core, warm sepia 3 surface	LB II
29	3822	Bowl	Some light grits, poorly made, permanent brown 3 core, burnt umber 3 surface, blackened by fire inside (see p. 158)	LB II
30	P 64	Bowl	Many large mixed grits, charcoal gray 3 core, near naples yellow 1 surface	EI I
	P 80-81	Bowls	Same type as No. 30 except for burnt umber 3 surface	EI I
31	3912	Bowl	Many mixed grits, poorly made, charcoal gray 3 and burnt umber 3 core, burnt umber 3 surface	LB II
32	3869	Bowl	Some mixed grits, burnt umber 3	LB II
33	3911	Jar	Many mixed grits, well fired, charcoal gray 3 core, burnt umber 3 surface; perhaps part of No. 1 on Pl. 63	LB II

TOMB 63 E



TOMB 63 F

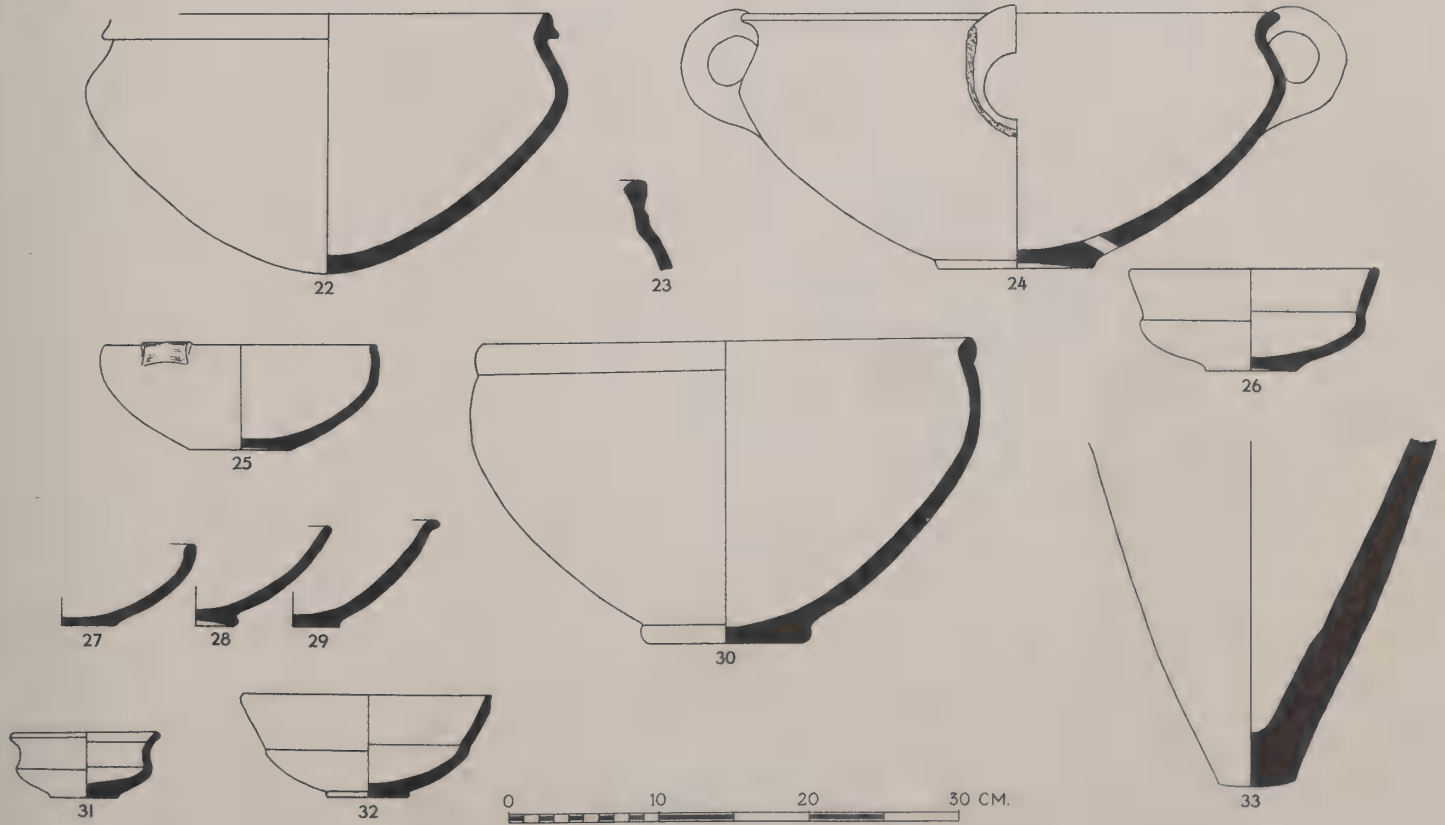

LB II AND IRON AGE POTTERY FROM TOMB 63 (SEE PP. 108-11). SCALE, 1:5

No.	Field No.	Designation	Description	Date
TOMB 63 F				
1	3877	Jar	Many mixed grits, well fired, charcoal gray 3 core, burnt umber 3 surface, indian red 3 decoration; repaired in antiquity with lime cement; possibly part of No. 33 on Pl. 62	LB II
2	P 43	Jar	Many mixed grits, poorly made, near naples yellow 3, handmade	?
3	3880	Jug	Many minute dark grits, near raw umber 3 core, light red 2 slip, blue-black 3 and naples yellow 1 decoration. See Pl. 158:16 for photograph.	?
4	3820	?	Few light grits, lightly fired, permanent brown 3 core, near naples yellow 1 surface, blackened by fire outside. See Pl. 158:17 for photograph.	?
5	P 44	Flask	Many light grits, near burnt umber 3, indian red 3 decoration. See Pl. 158:14 for photograph.	EI I
6	3885	Jug	Fine ware, some minute mixed grits, blue-black 3 core, darker surface, close vertical burnishing (cf. <i>OIP</i> XLII, Pl. 5, Nos. 124-27)	E-MI
		Jugs (14)	Same type as No. 6	E-MI
7	3884	Jug	Same as No. 6	E-MI
8	3855	Jug	Many light grits, permanent brown 3 core, light red 1 slip, spaced horizontal burnishing	E-MI?
	P 68	Jug	Intact, some large mixed grits, well fired, burnt umber 2 surface, indian red 3 decoration. See Pl. 158:12 for photograph.	LB II
0	3852	Jug	Same as No. 9 except for burnt umber 3 core	LB II
11	3853	Jug	Same as No. 9 except for burnt umber 3 core	LB II
12	3851	Jug	Same as No. 9 except for charcoal gray 3 core	LB II
13	3888	Jug	Same as No. 9 except for charcoal gray 3 core	LB II
14	3856	Jug	Few mixed grits, lightly fired, chiefly permanent brown 3 core, mars yellow 1 surface, traces of indian red 3 wash	LB II
15	P 152	Jug	Many large mixed grits, poorly made, well fired, sepia 3 core, chiefly burnt umber 3 surface	LB II
16	P 62	Jug	Very many minute light grits, well made, well fired, vandyke brown 3 core, permanent yellow 3 slip, rubens madder 2 decoration. See Pl. 158:11 for photograph.	LB II
17	P 41	Jug	Fine ware, many minute light grits, heavily fired, blue-black 3 core, chiefly light red 3 and charcoal gray 3 surface, near davy's gray 3 decoration, handmade; Cypriote <i>bucchero</i> ware (see p. 158). See Pl. 158:13 for photograph.	LB II
TOMB 63 G				
18	3922	Bowl	Many large light grits, poorly made, well fired, burnt umber 3	LB II
19	3919	Bowl	D. .50, coarse ware, some large light grits, well fired, charcoal gray 3 core, burnt umber 3 surface, impressed decoration from binding-cord	LB II?
20	3917	Jar	Many light grits, well fired, sepia 3 core, burnt umber 3 surface, indian red 3 decoration	LB II
21	3914	Jar	Fine ware, few minute dark grits, well made, well fired, permanent brown 3 core, naples yellow 1 surface, brown ocher 2 decoration	?
TOMB 63 H				
22	3936	Bowl	Few light grits, permanent brown 3 core, light red 2 wash inside and burnt umber 3 outside, spaced irregular burnishing	MI
23	3938	Bowl	Poorly made, well fired, permanent brown 3 core, burnt umber 3 surface	LB II
TOMB 63 J				
24	3961	Bowl	Same as No. 23	LB II
25	3969	Bowl	Many large light grits, charcoal gray 3 core, near burnt umber 3 surface	EI I
26	3939	Bowl	D. .70, coarse ware, many large light grits, well fired, charcoal gray 2 core, near burnt umber 3 surface	EI I
27	3953	Bowl	Many minute mixed grits, well fired, light red 1 to permanent brown 3 core, light red 3 surface, traces of naples yellow 1 slip	M-LI
28	3947	Cooking bowl	D. .41, coarse ware, many mixed grits, poorly made, blue-black 3 core, near burnt umber 3 surface, blackened by fire	?
29	3967	Jar	Fine ware, many large light grits, well fired, blue-black 3 core, light red 2 surface, black lead 3 and indian red 3 decoration	EI I
30	3965	Jar	Same as No. 25	LB II
31	3963	Bilbil	Fine ware, many minute light grits, well fired, black lead 3 core, sepia 3 wash, davy's gray 1 decoration, handmade; Cypriote	LB II
TOMB 63 L				
32	3974	Bowl	Same as No. 22	MI
33	3971	Cooking bowl	D. .30; same as No. 28	?
34	3975	Jar-stand	D. .21, some minute mixed grits, well made, well fired, charcoal gray 3 core, naples yellow 1 surface	MI

TOMB 63 F

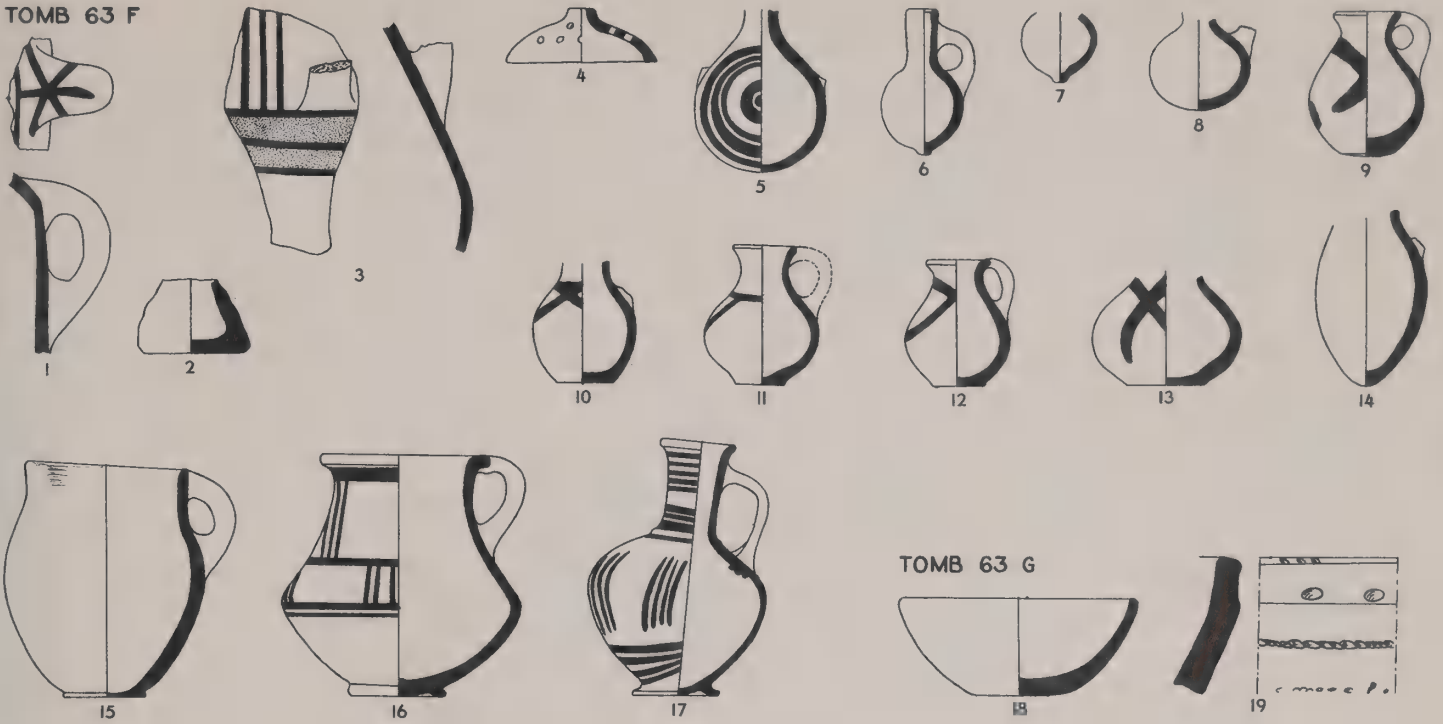

TOMB 63 G

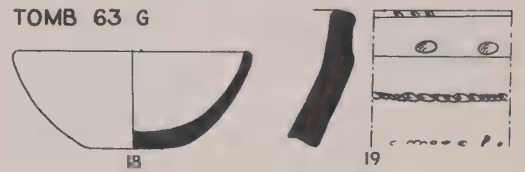

TOMB 63 H

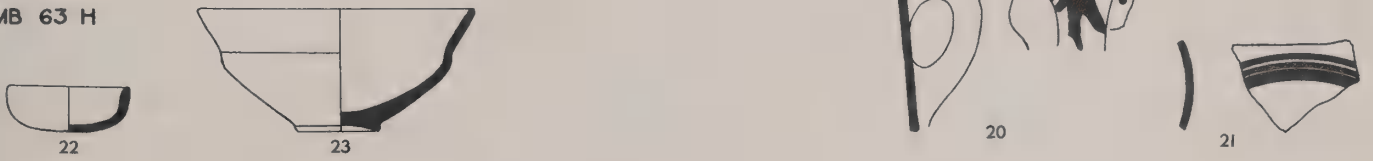

TOMB 63 J

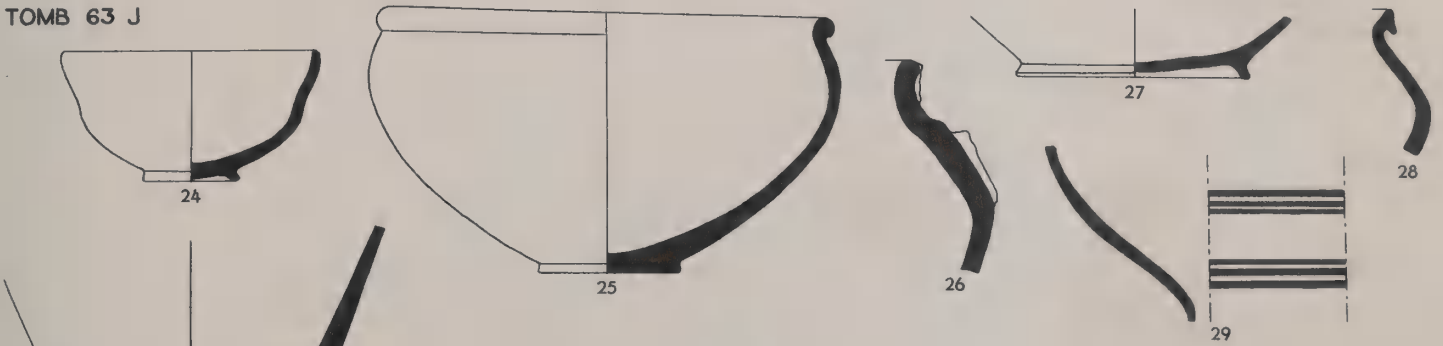

TOMB 63 L

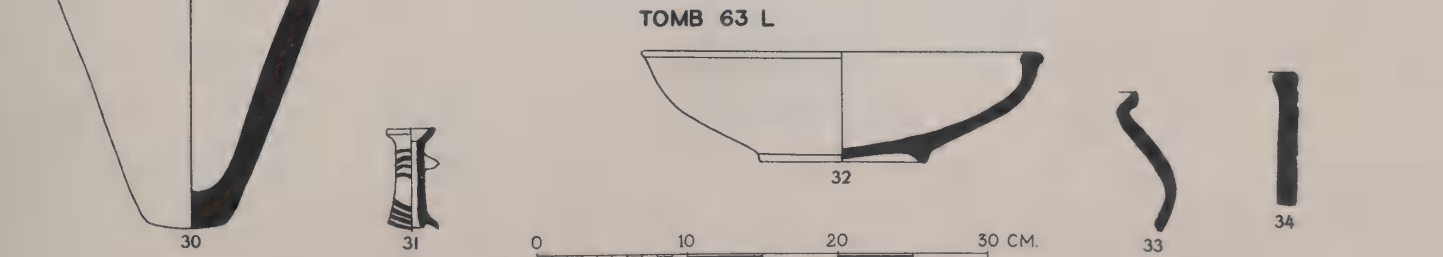

POTTERY FROM TOMB 63 (SEE PP. 108-11). SCALE, 1:5

No.	Field No.	Description	Date
1	4262	Many large light grits, sepia 3 core, near burnt umber 3 surface, indian red 3 decoration inside	LB II
2	P 96	Same as No. 1 except for permanent brown 3 core	LB II
3	4287	Many light grits, poorly made, blue-black 3 core, near burnt umber 2 surface	LB II
	4286	Same type as No. 3 except for fewer grits	LB II
4	4295	Coarse ware, many large light grits, poorly made, near burnt umber 3	LB II
	4297	Same shape as No. 4 with ware like that of No. 3	LB II
5	4266	Some light grits, poorly made, charcoal gray 3 core, near naples yellow 1 surface	LB II
6	P 89	Blue-black 3 core, near burnt umber 3 surface	LB I
7	4296	Many light grits, blue-black 3 core, burnt umber 3 surface	LB II
8	4293	Many light grits, poorly made, near burnt umber 3 core, darker surface	LB II
	4275 } 4282 } 4289 } 4292 }	Same type as No. 8	LB II
9	4274	Same as No. 8 except for near burnt umber 3 and charcoal gray 3 core	LB II
	P 100	Same shape as No. 9 with ware like that of No. 5 except for burnt umber 3 core	LB II
10	4269	Same as No. 9 except for fewer grits and spaced horizontal burnishing outside	LB II
11	4270	Same as No. 3 except for lighter surface	LB II
12	4271	Same as No. 6	LB II
13	4265	Same as No. 4 except that it is fairly well made and has fewer grits	LB II
14	4284	Warm sepia 3 core, naples yellow 1 surface, hole in base apparently bored	LB II
15	4298	Same as No. 6; mended in antiquity with lime cement	LB II
16	4300	Same as No. 6; blackened by fire inside	LB I
	P 97 } 4276 }	Same type as No. 16	LB I
17	4272	Same as No. 14 except for large light grits	LB I
	P 90	Same shape as No. 17 with ware like that of No. 6	LB I
18	4299	Same as No. 11	LB I
	4278 } 4301 }	Same shape as No. 18 with ware like that of No. 8	LB I
19	4285	Near burnt umber 3	LB II
	4288	Same shape as No. 19, many large light grits, poorly made, well fired, chiefly burnt umber 2 core, lighter surface	LB II
20	4273	Same as No. 6	LB II
21	4283	Same as No. 5 except for lighter core	LB II
	4267 } 4279 } 4281 } 4291 }	Same type as No. 21; No. 4281 has a hole in its base	LB II
22	4302	Same as No. 6	LB II
23	4303	Same as No. 6 except that it is poorly made	LB II
24	4294	Same as No. 6	LB II
25	4277	Same as No. 6	LB II
26	4280	Same as No. 6	LB II
27	4268	Same as No. 3	LB II
28	P 104	Fine ware, few minute grits, well made, near naples yellow 1, indian red 3 decoration; Mycenaean(?) (see pp. 113 and 157)	LB II
29	4168	Fine ware, few minute mixed grits, poorly made, burnt umber 3 core, naples yellow 1 slip, burnt umber 1 decoration, handmade; Cypriote milk bowl (see p. 158)	LB II
30	P 94	Fine ware, some minute light grits, well fired, blue-black 3, handmade; Cypriote milk bowl	LB
31	4170	Same as No. 6 except for chiefly permanent brown 3 core (see pp. 113 and 115)	LB II?
32	4305	Many large light grits, well fired, burnt umber 3 core, near naples yellow 1 surface	EI I
33	P 102	Many mixed grits, charcoal gray 3 core, near burnt umber 3 surface. See Pl. 159:1 for photograph.	EI I
34	3997	Well fired, chiefly charcoal gray 3 core, light red 3 surface, spaced horizontal burnishing outside and over rim, indian red 3 decoration. See Pl. 159:2 for photograph.	EI I
35	P 200	Well fired, charcoal gray 2 core, burnt umber 3 surface, traces of burnishing outside and just over rim, purple madder 3 decoration. See Pl. 159:3 for photograph.	EI I
36	4258	Rim d. .30, permanent brown 3 core, near burnt umber 3 surface, indian red 3 decoration	EI I
37	4290	Many mixed grits, poorly made, sepia 3 core, near burnt umber 2 surface	EI I
38	4241	D. .32; same as No. 6 except for indian red 3 decoration on handle	EI I
39	4173	Permanent brown 3 core, near naples yellow 1 surface	MI
40	4198	Permanent brown 3 core, lighter outside surface, light red 2 wash inside and over rim, spaced horizontal burnishing	MI
	4199 } 4201 }	Same type as No. 40	MI

TOMB 73

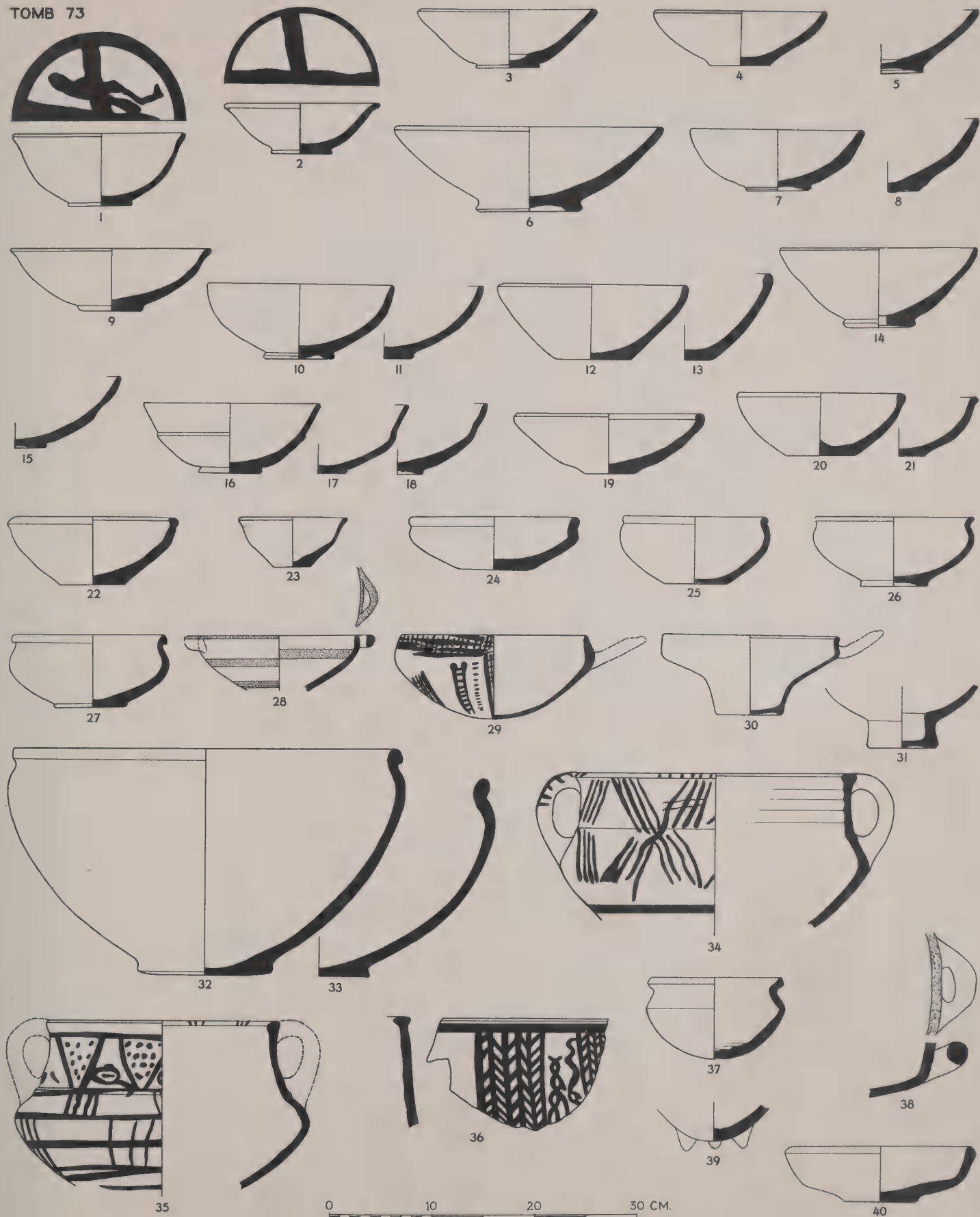

LB AND IRON AGE POTTERY BOWLS FROM TOMB 73 (SEE PP. 111-13 AND 115). SCALE, 1:5

No.	Field No.	Designation	Description	Date*
1	4197	Bowl	Permanent brown 3 core, lighter outside surface, light red 2 wash inside and over rim, spaced horizontal burnishing	MI
2	4163	Bowl	Charcoal gray 3 core, near warm sepia 3 surface, light red 3 wash inside and over rim, close horizontal burnishing (cf. <i>OIP</i> XLII, Pl. 26, No. 81)	MI
3	4202	Leg of bowl	Some minute mixed grits, well made, charcoal gray 3 core, light red 1 wash, close vertical burnishing, vertical grooves. See Pl. 160:21 for photograph.	E-MI
4	4164	Bowl	Permanent brown 3 core, near burnt umber 3 surface	LB I?
5	4200	Bowl	D. .27, few minute mixed grits, near burnt umber 3 core, lighter inside surface, indian red 2 wash outside and over rim, close horizontal burnishing	Stages III-V. Col. 14 C
6	4016	Chalice	Many large light grits, charcoal gray 3 core, naples yellow 1 surface	LB II
7	4260	Chalice	D. .20; same as No. 6 except for light red 1 decoration on rim	LB II
8	4263	Jar	Many mixed grits, well fired, charcoal gray 2 core, brown madder 2 surface, purple madder 3 decoration	LB II
9	P 167	Jar	Many mixed grits, charcoal gray 3 core, burnt umber 3 surface	LB II
10	4188	Jar	Same as No. 8 except for burnt umber 3 core	LB II
11	4160	Jar	Some minute mixed grits, charcoal gray 3 core, permanent yellow 3 surface	LB II
12	4251	Jar	Permanent brown 3 core, near burnt umber 3 surface, indian red 3 decoration	LB II
13	4166	Jar	Many large light grits, well fired, charcoal gray 3 to near naples yellow 3 core, light red 2 to naples yellow 3 surface, indian red 3 decoration	LB II
14	4180	Jar	Many minute mixed grits, light red 1, pottery mark	LB II
15	4306	Jar	Rim d. .365, charcoal gray 3 core, burnt umber 3 surface, traces of indian red 2 wash	?
16	4304	Jar	D. .43, many dark grits, charcoal gray 3 core, burnt umber 2 surface (cf. <i>OIP</i> XLII, Pl. 18, No. 93)	MI
17	4177	Jar	D. .27, some minute mixed grits, well fired, burnt umber 1 (cf. <i>OIP</i> XLII, Pl. 16, No. 81)	MI
18	4019	Jar	D. .36, well fired, charcoal gray 3 core, near burnt umber 3 surface (cf. <i>ibid.</i> )	MI
19	P 103	Jar	Sepia 1 core, naples yellow 1 surface, traces of indian red 3 wash. See Pl. 159:14 for photograph.	MI
20	4211	Jar	Few minute mixed grits, blue-black 3, close vertical burnishing (cf. <i>OIP</i> XLII, Pl. 19, No. 97)	EI II
21	P 107	Jar-stand	Some large mixed grits, charcoal gray 3 core, burnt umber 3 surface (see p. 154). See Pl. 159:10 for photograph.	LB II
22	4015	Jug	Many mixed grits, charcoal gray 3 core, burnt umber 3 surface, traces of vertical shaving	LB II
23	4161	Jug	Permanent brown 3 core, burnt umber 3 surface, traces of vertical shaving	LB II
24	P 88	Jug	Same as No. 22 except for fewer grits	LB II
25	3990	Jug	Many mixed grits, burnt umber 3, traces of vertical shaving	LB II
26	4018	Jug	Burnt umber 3, traces of vertical shaving	LB II
27	3989	Jug	Same as No. 22 except for permanent brown 3 core	LB II
	3992 } 4017 }	Jugs	Same type as No. 27	LB II
28	P 87	Jug	Same as No. 13 except for no decoration. See Pl. 159:11 for photograph.	LB II

\* "Stages" do not date a given piece but indicate the duration of its type. See *SAOC* No. 10, pp. 52-65 and chart.

TOMB 73

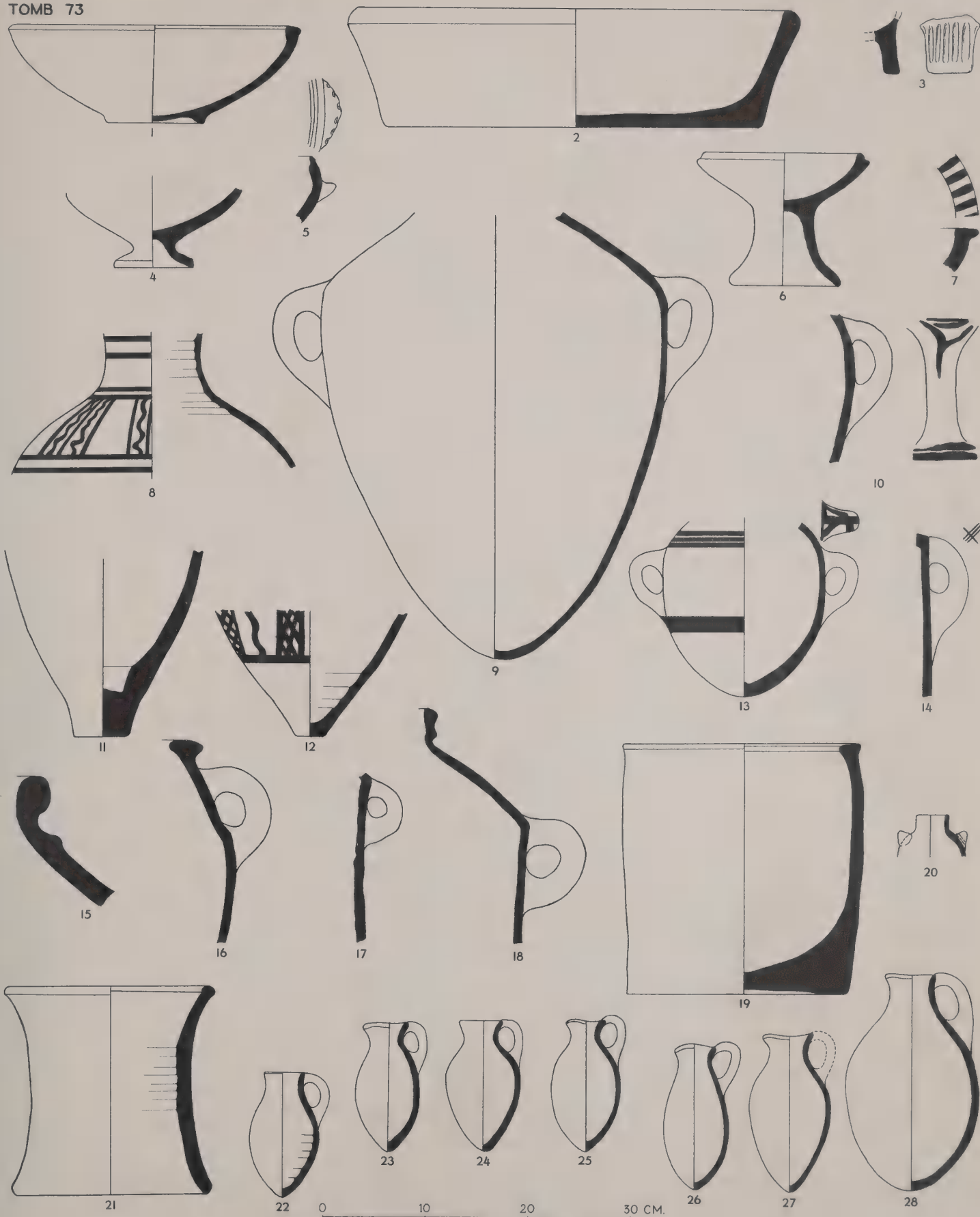

POTTERY FROM TOMB 73 (SEE PP. 111-13 AND 115). SCALE, 1:5

No.	Field No.	Designation	Description	Date
1	P 93	Jug	Many large light grits, well fired, charcoal gray 3 to near naples yellow 3 core, light red 2 to naples yellow 3 surface (see p. 155)	LB II
2	P 110	Jug	Many mixed grits, chiefly warm sepia 2 core, chiefly light red 3 surface, traces of indian red 3 wash (see p. 155). See Pl. 159:12 for photograph.	LB II
3	P 157	Jug	Same as No. 1 except for light red 1 to roman sepia 3 core	LB II
4	P 111	Jug	Same as No. 1 except for light red 1 core	LB II
5	P 95	Bilbil	Fine ware, many minute light grits, well fired, chiefly charcoal gray 3 core, blue-black 3 surface, relief decoration, handmade; Cypriote	LB I
6	4158	Jug	Fine ware, few minute dark grits, well made, well fired, naples yellow 1, spaced horizontal burnishing, purple madder 2 decoration	LB II
7	P 86	Jug	Many large light grits, poorly made, heavily fired, roman sepia 3 core, much lighter surface	LB II
8	3987	Jug	Same as No. 1 except for indian red 1 and 3 decoration	LB II
9	3998	Jug	Same as No. 1 except for indian red 3 decoration. See Pl. 159:7 for photograph.	LB II
10	P 84	Jug	Few mixed grits, burnt umber 3, permanent yellow 3 slip, indian red 3 decoration. See Pl. 159:8 for photograph.	LB II
11	4167	Jug	Many mixed grits, charcoal gray 3 to burnt umber 3 core, near burnt umber 3 surface, indian red 3 decoration	LB II
12	P 85	Jug	Many mixed grits, well fired, near naples yellow 1, near burnt umber 3 decoration probably faded from indian red 3. See Pl. 159:6 for photograph.	LB II
13	4165	Jug	Well fired, permanent brown 3 core, light red 2 to naples yellow 3 surface, indian red 3 decoration. See Pl. 159:9 for photograph.	LB II
14	4154	Jug	Permanent brown 3 core, burnt umber 3 surface, indian red 3 decoration (see p. 159). See Pl. 159:5 for photograph.	LB II?
15	P 109	Jug	Some minute mixed grits, well fired, burnt umber 3 core, chiefly brown ocher 1 surface	MI
16	4190	Jug	Fine ware, few minute mixed grits, well made, heavily fired, burnt umber 3, close horizontal burnishing, near bister 3 decoration; Cypriote (cf. <i>OIP</i> XLII, Pl. 21, No. 123)	EI II
17	5531	Drain	Few mixed grits, straw tempered, permanent brown 3 to charcoal gray 3 core, near davy's gray 1 surface. See Pl. 159:15 for photograph.	M-LI
18	P 76	Bottle	Some minute dark grits, lightly fired, naples yellow 1. See Pl. 159:4 for photograph.	LB II
19	P 106	Flask	T. 190, coarse ware, many large mixed grits, light red 2, indian red 3 decoration. See Pl. 159:13 for photograph.	LB II
20	4254	Flask	Many minute light grits, well fired, permanent brown 3 core, brown ocher 3 surface, close vertical burnishing, indian red 3 and blue-black 3 decoration	EI
21	3988	Lamp	Charcoal gray 2 core, burnt umber 3 surface (see p. 156)	LB II
	4157 4171 4183 4187	Lamps	Same type as No. 21	LB II
22	4162	"Cup and saucer"	Many mixed grits, charcoal gray 3 core, naples yellow 1 surface	LB II
23	4175	"Cup and saucer"	Many mixed grits, charcoal gray 3 core, burnt umber 3 surface	LB II

TOMB 73

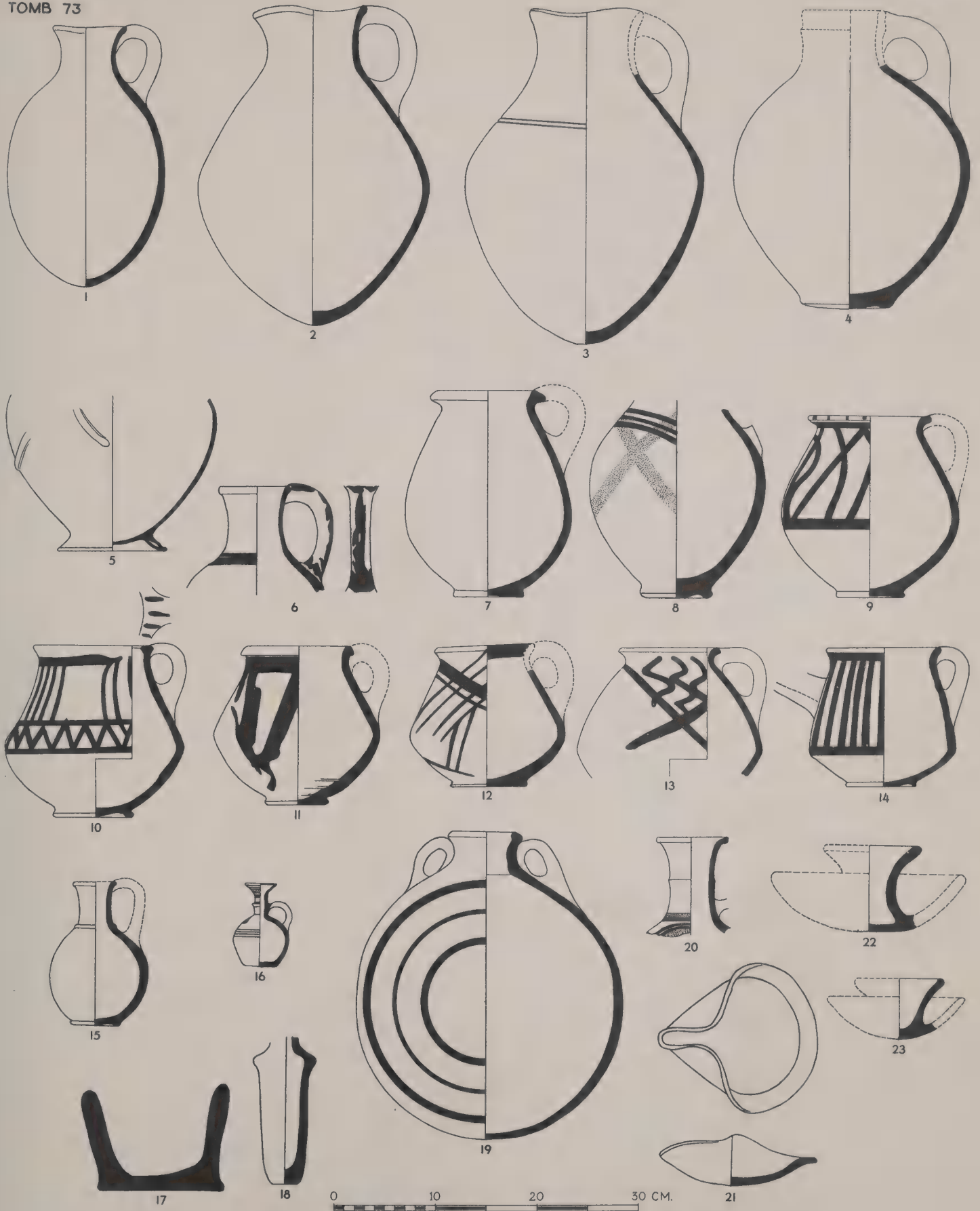

LB AND IRON AGE POTTERY FROM TOMB 73 (SEE PP. 111-13 AND 115). SCALE, 1:5

No.	Field No.	Designation	Description
1	P 5075	Bowl	Lightly fired, roman sepia 2 core, brown ocher 1 surface
2	P 5073	Milk bowl	Many minute light grits, blue-black 3 core, naples yellow 3 slip, irregular burnishing, vandyke brown 1 decoration, handmade; Cypriote
3	P 5074	Milk bowl	Same as No. 2
4	P 5071	Jug	Intact, many minute mixed grits, well fired, black lead 3 to brown ocher 3 surface, traces of blue-black 2 wash outside and over rim, traces of whitewash outside, incised lines on handle; local imitation of Cypriote bilbil (see p. 158)
5	P 5079	Jug	Many mixed grits, brown ocher 1
6	P 5072	Jug	Same as No. 4
7	P 5077	Jar	Some large mixed grits, lightly fired, blue-black 3 core, brown ocher 1 surface
	P 5078	Jar	Same type as No. 7 except for smaller grits and naples yellow 2 core and surface (see Fig. 140); LB II

TOMB 1250

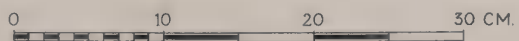
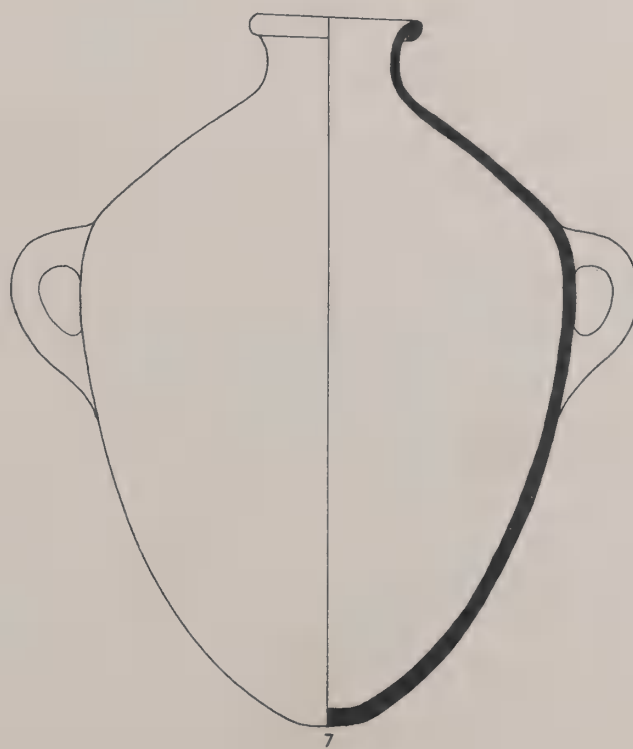
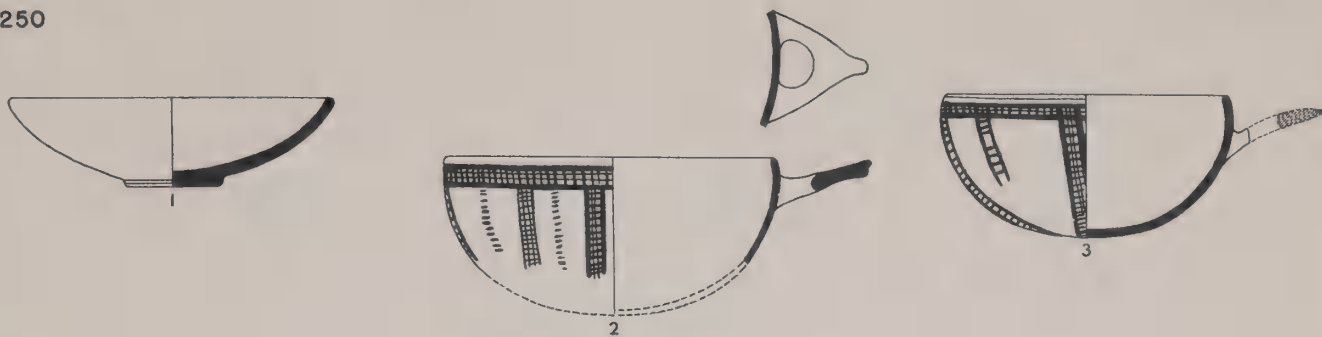

LB II POTTERY FROM TOMB 1250 (SEE P. 116). SCALE, 1:5

No.	Field No.	Designation	Description
TOMB 17			
1	399	Bowl	Brown ocher 3; found inside No. 3
2	397	Flask	Indian red 3 core, light red 3 surface, indian red 3 decoration (see p. 159)
	398	Flask	Same type as No. 2
3	400	Bowl	Charcoal gray 3 core, brown ocher 3 surface
		Bead	Carnelian, circular; EI I
		Flint	Scraper; EI I
TOMB 29			
4	x 2929	Bowl	Same as No. 3 (see p. 159)
5	x 2926	Bowl	Brown ocher 3, indian red 3 decoration on rim
	x 2927	Bowl	Same type as No. 5; EI I
6	x 2928	Jug	Brown ocher 3 (see p. 159)
7	x 2925	Bowl	Brown ocher 3, indian red 3 decoration, 4 handles
8	x 2930	Jug	Brown ocher 3, slightly polished, indian red 2 decoration, 10-hole strainer spout, 1 handle (see p. 159)
TOMB 39			
9	x 711	Flask	T. .05, brown ocher 3, naples yellow 3 slip, indian red 3 decoration (see p. 159)
	763-66	} Flasks	Same type as No. 9 (see Fig. 143); EI I
	x 17		
	x 80		
	x 712-16		
	x 731-34		
10	767	Flask	Burnt umber 3, indian red 3 decoration (see p. 160). See Pl. 164:5 for photograph.
11	x 710	Lamp	Brown ocher 3. See Pl. 164:14 for photograph.
	x 721	Lamp	Same type as No. 11; EI I
12	x 706	Cooking bowl	Blue-black 3 core, permanent brown 3 surface, naples yellow 3 wash
13	2824	Bowl	Brown ocher 3, indian red 3 decoration on rim
14	768	Bowl	Burnt umber 2
15	x 0718	Bowl	Burnt umber 3, indian red 3 decoration
16	756	Bowl	Burnt umber 3, indian red 2 decoration, 8 handles. See Pl. 164:7 for photograph.
17	x 86	Jug	Brown ocher 3 core, naples yellow 3 surface
18	x 720	Jug	Same as No. 17 (see p. 159)
19	760	Chalice	Same as No. 17 (see p. 159)
20	752	Chalice	Burnt umber 3 (see p. 159). See Pl. 164:11 for photograph.

TOMB 17

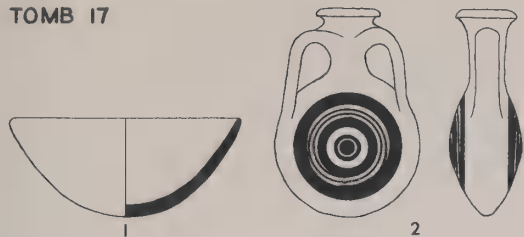

TOMB 29

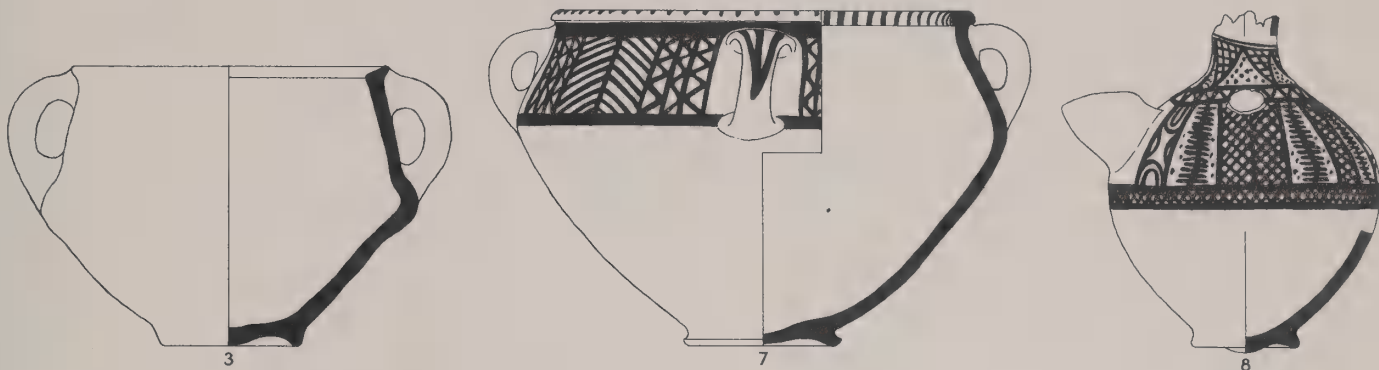

TOMB 39

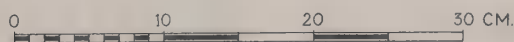
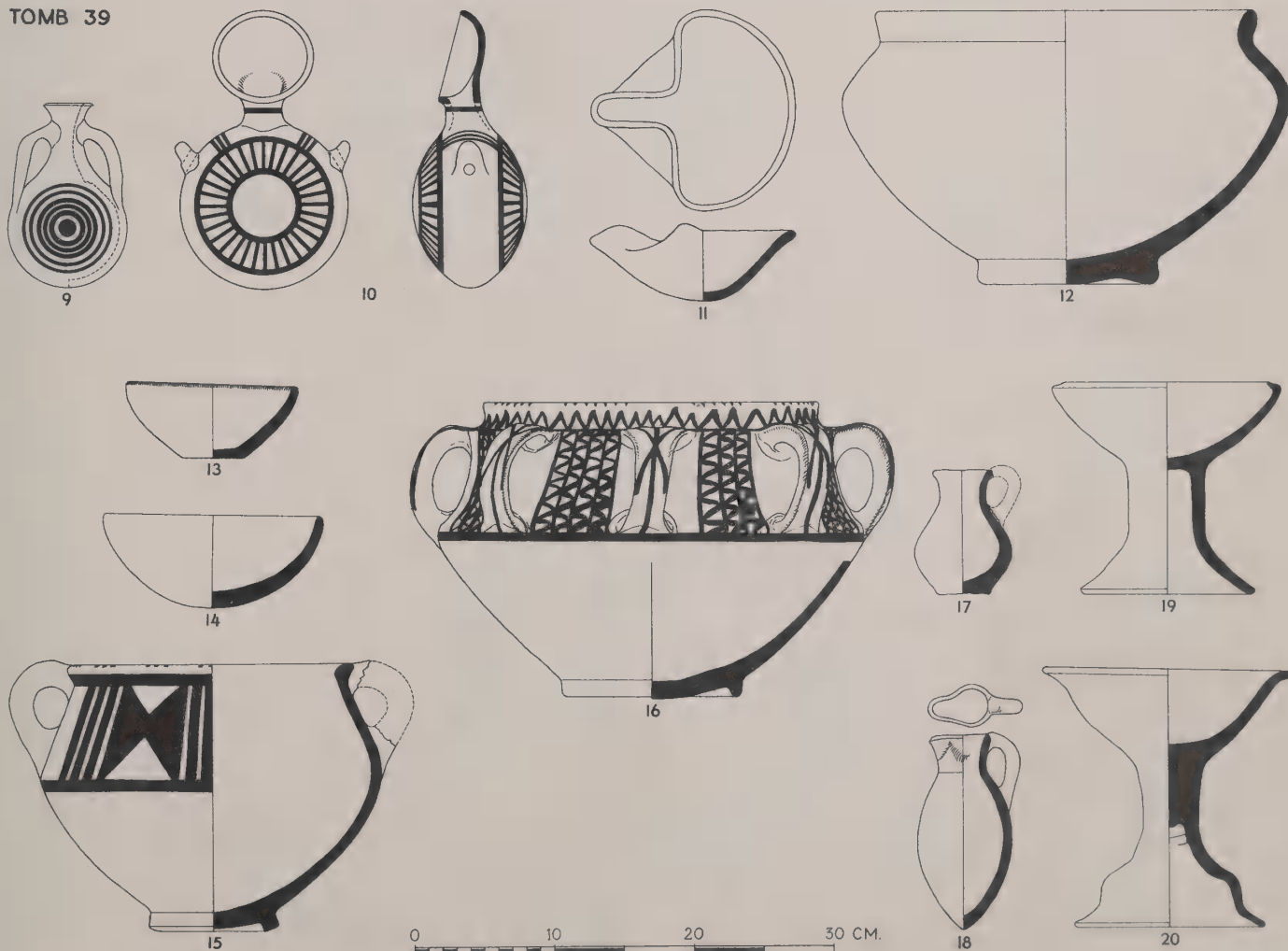

EI I POTTERY FROM TOMBS 17, 29, AND 39 (SEE PP. 117-19). SCALE, 1:5

No.	Field No.	Designation	Description
TOMB 39			
1	753	Jar	Burnt umber 3 (see p. 159)
2	x 730	Jar	Burnt umber 3, indian red 3 decoration (see p. 159). See Pl. 164:15 for photograph.
3	x 708	Bowl	Charcoal gray 3 core, brown ocher 3 surface (see p. 159). See Pl. 164:12 for photograph.
4	751	Jar	Permanent brown 3
	754-55 } 761 }	Jars	Same type as No. 4; EI I
5	762	Bowl	Burnt umber 3, 3 finger impressions at base of each handle (see p. 159). See Pl. 164:21 for photograph.
6	759	Bowl	Brown ocher 3, naples yellow 3 slip; badly warped
TOMB 62			
7	P 47	Bowl	Intact, some light grits, well fired, brown ocher 1 (see p. 159)
	P 48	Bowl	Intact; same type as No. 7 except for burnt umber 2 surface (see Fig. 146); EI I
	P 49	Bowl	Same type as No. 7 except for burnt umber 2 core and surface (see Fig. 146); EI I
8	P 50	Bowl	Intact, many grits, burnt umber 2, light red 2 wash on rim (see p. 159)
9	P 46	Bowl	Intact, some large grits, well made, well fired, burnt umber 3, indian red 1 decoration
10	P 11	Jug	Intact, some light grits, poorly made, brown ocher 1, vertical shaving

TOMB 39

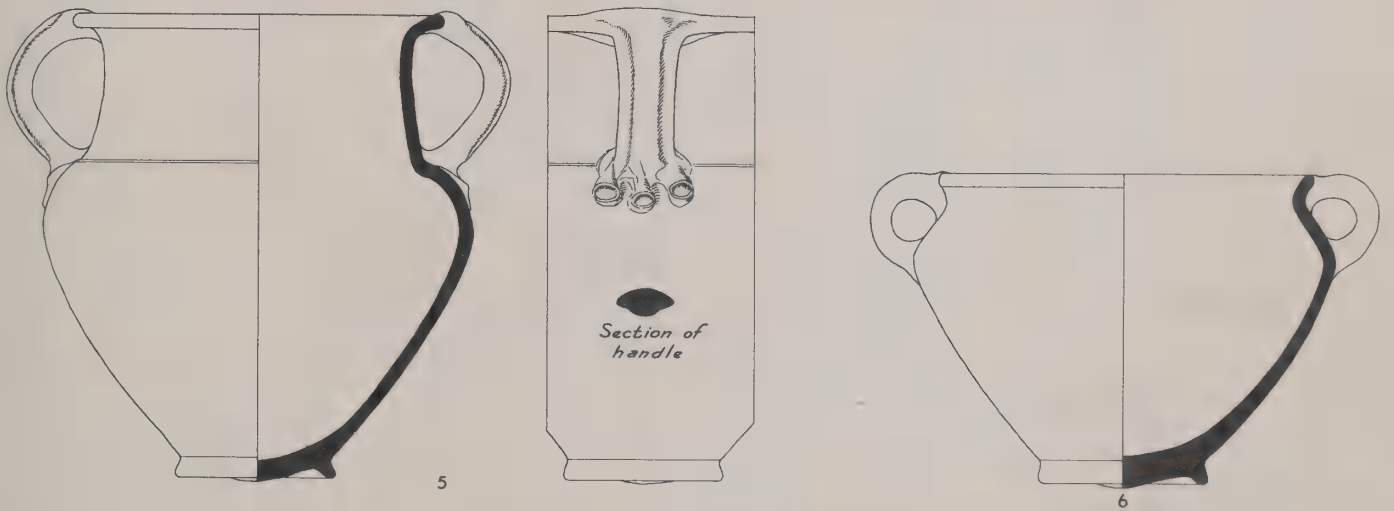

TOMB 62

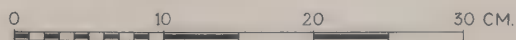
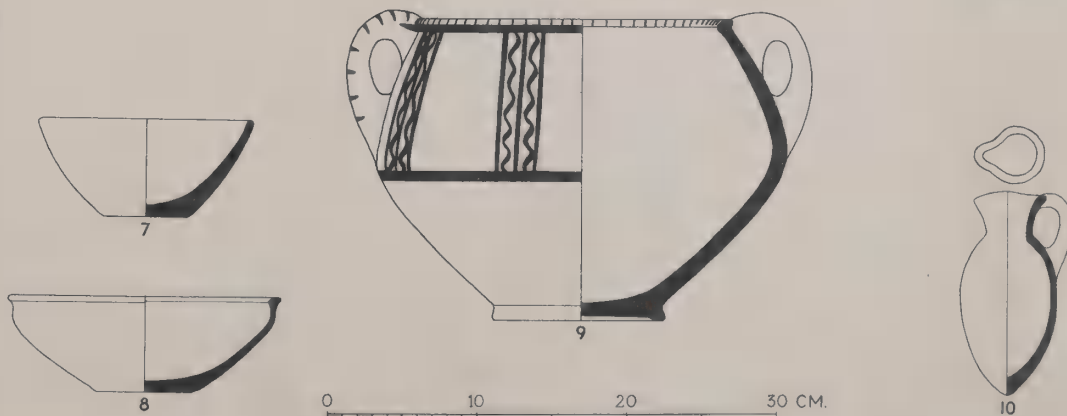

EI I POTTERY FROM TOMBS 39 AND 62 (SEE PP. 117-19). SCALE, 1:5

No.	Field No.	Designation	Description
TOMB 62			
1	P 10	Jar	Some light grits, burnt umber 3
TOMB 71			
2	P 72	Flask	Intact, t. .062, near brown ocher 2 surface, indian red 3 decoration (spiral around ringed dot)
3	3994	Flask	T. .060; same as No. 2 except for brown ocher 2 core and no ringed dot
4	P 73	Jar	Many large light grits, naples yellow 1, traces of near light red 3 wash
TOMB 72			
5	P 75	Flask	Intact, t. .07; same as No. 2
	P 74	Jar	Same shape as No. 4, many minute mixed grits, permanent brown 3 core, chiefly warm sepia 3 surface (see Fig. 148); EI I
TOMB 221 A			
6	P 252	Lamp	Blue-black 3 core, light red 2 wash (cf. <i>OIP</i> XLII, Pl. 37, No. 11). See Pl. 169:5 for photograph.
TOMB 221 B			
7	P 327	Bowl	Some large mixed grits, blue-black 3 core, burnt umber 2 surface
8	3561	Bowl	Same as No. 9 except for more grits
9	P 339	Bowl	Permanent brown 3 core, naples yellow 2 surface. See Pl. 169:7 for photograph.
10	P 328	Bowl	Same as No. 9. See Pl. 169:8 for photograph.
11	P 321	Bowl	Same as No. 7 except for roman sepia 2 core. See Pl. 169:6 for photograph.
12	P 350	Bowl	Blue-black 3 and permanent brown 3 core, chiefly naples yellow 2 surface, indian red 3 decoration
13	P 324	Bowl	Many large mixed grits, well fired, blue-black 2 core, naples yellow 1 to burnt umber 3 surface, 4 handles. See Pl. 169:9 for photograph.
14	P 323	Bowl	Many large mixed grits, well fired, permanent brown 3 core, naples yellow 2 surface, 4 handles. See Pl. 169:10 for photograph.
15	P 349	Bowl	Same as No. 14 except for moderate firing. See Pl. 169:11 for photograph.
16	4318	Bowl	Some large mixed grits, roman sepia 2 core, burnt umber 2 surface
17	P 348	Bowl	Many large mixed grits, well fired, permanent brown 3 core, brown ocher 2 surface

TOMB 62



TOMB 71

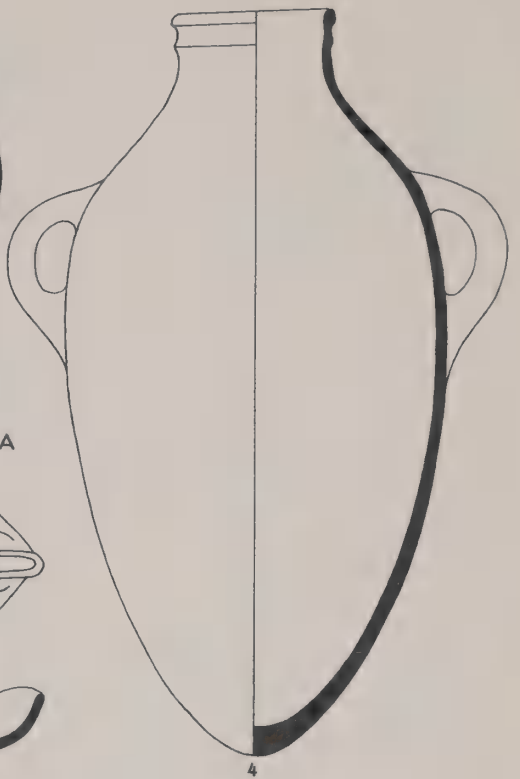

TOMB 72



TOMB 221 A



TOMB 221 B

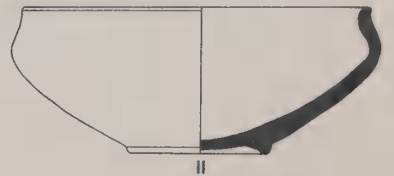
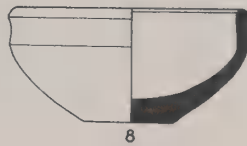
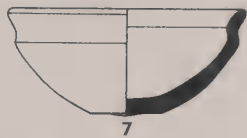

TOMB 221 B

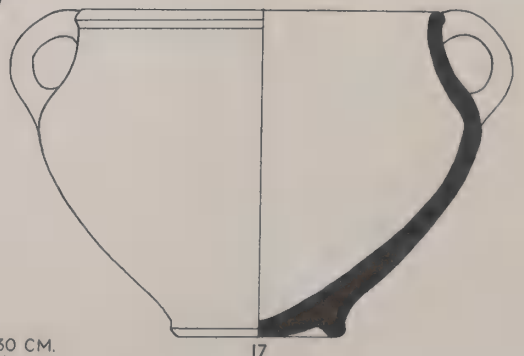
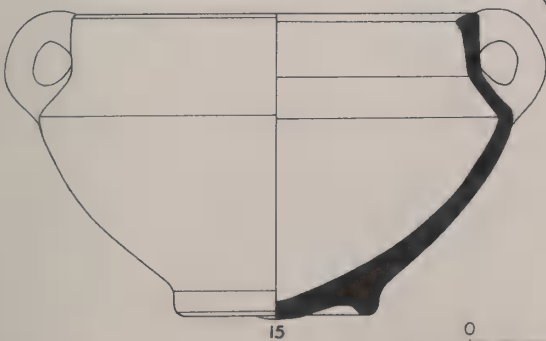
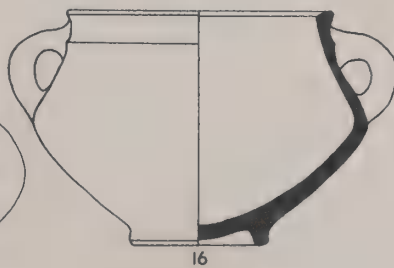
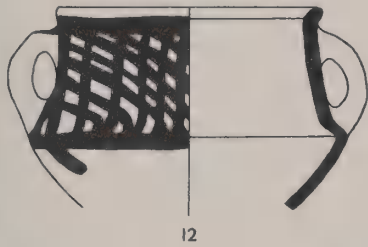
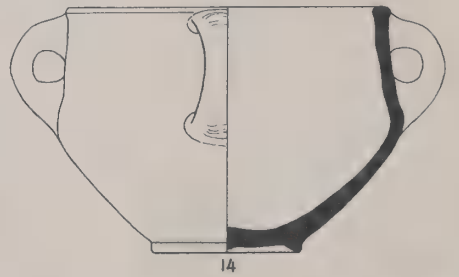
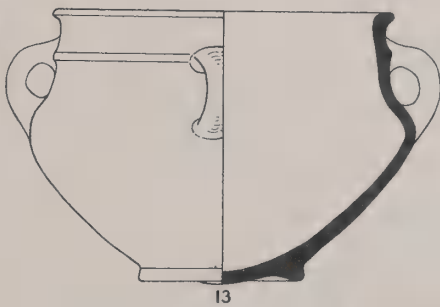
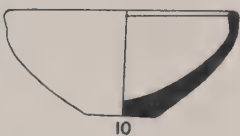
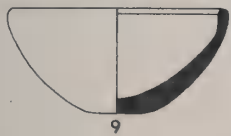

EI I POTTERY (No. 6 MI) FROM TOMBS 62, 71-72, AND 221 (SEE PP. 119-23 AND 125). SCALE, 1:5

No.	Field No.	Designation	Description
1	P 337	Bowl	Some large mixed grits, permanent brown 3 core, naples yellow 2 surface
2	P 332	Bowl	Few mixed grits, well fired, permanent brown 3 core, burnt umber 3 surface, incised decoration. See Pl. 169:12 for photograph.
3	P 338	Bowl	Many large mixed grits, well fired, permanent brown 3 core, naples yellow 1 to burnt umber 3 surface
4	P 320	Bowl	Some large mixed grits, poorly made, well fired, blue-black 3 core, naples yellow 3 surface
5	P 319	Bowl	Many large mixed grits, blue-black 3 core, naples yellow 2 surface
6	P 335	Bowl	Many large mixed grits, well fired, permanent brown 3 core, brown ocher 2 surface
7	P 347	Bowl	Fine ware, some large mixed grits, well fired, brown ocher 3
8	P 322	Bowl	Many mixed grits, chiefly blue-black 3 core, burnt umber 3 surface
9	4347	Bowl	Same as No. 5 except for chiefly permanent brown 2 core
10	P 317	Bowl	Many large light grits, poorly made, permanent brown 3 core, naples yellow 3 to brown ocher 2 surface, light red 3 wash
11	P 318	Bowl	Many large light grits, well fired, brown ocher 1 core, burnt umber 2 surface
12	4319	Bowl	Naples yellow 1 core, lighter surface
13	P 333	Bowl	Same as No. 6 except for blue-black 3 core
14	4346	Bowl	Same as No. 5
15	P 331	Bowl	Same as No. 11 except for permanent brown 3 core
16	P 334	Bowl	Same as No. 4
17	P 336	Chalice	Poorly made, permanent brown 3 and blue-black 3 core, naples yellow 2 surface (see p. 159). See Pl. 169:15 for photograph.
18	P 340	Lamp	Few mixed grits, poorly made, permanent brown 3 core, burnt umber 2 surface (see p. 159)
19	P 346	Jar	Same as No. 18 (see p. 159)

TOMB 221 B

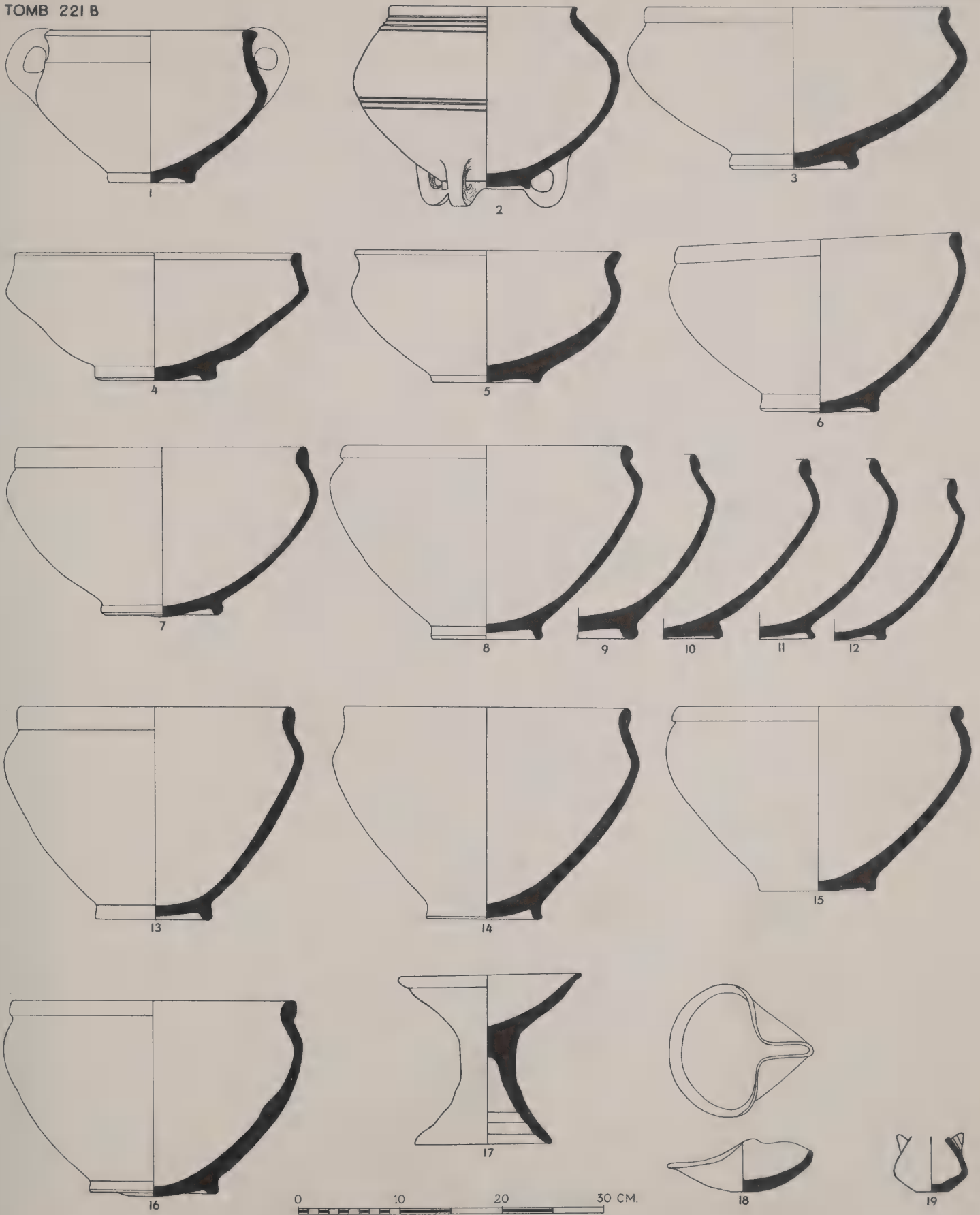

0 10 20 30 CM.

EI I POTTERY FROM TOMB 221 B (SEE P. 125). SCALE, 1:5

No.	Field No.	Designation	Description
TOMB 221 B			
1	P 325	Jar	Many large light grits, well fired, burnt umber 3 core, permanent brown 3 to burnt umber 2 surface, indian red 2 decoration (see p. 159). See Pl. 169:14 for photograph.
2	P 351	Jar	Well fired, naples yellow 2 core, chiefly burnt umber 3 surface. See Pl. 169:13 for photograph.
		Jars (5)	Same type as No. 2; EI I
	4349	Jar	Same shape as No. 2, many mixed grits, well fired, burnt umber 3 (see Fig. 151); EI I
3	P 341	Flask	Some minute mixed grits, well fired, blue-black 3 core, burnt umber 2 surface, indian red 3 decoration (spiral around ringed dot) (see p. 159). See Pl. 169:17 for photograph.
		Flasks (3)	Same type as No. 3; EI I
	P 343	Flask	Intact; same shape as No. 3, many mixed grits, poorly made, well fired, naples yellow 3 surface, indian red 3 decoration; EI I
	4317	Flask	Same type as No. 3 except for permanent brown 3 core; EI I
4	P 432	Flask	Same as No. 3 except for permanent brown 3 core. See Pl. 169:16 for photograph.
5	4320	Flask	Same as No. 3 except for moderate firing and permanent brown 3 core
6	P 344	Flask	T. .067, well fired, burnt umber 2 core, naples yellow 2 to burnt umber 2 surface, indian red 3 decoration (spiral around dot)
	P 330	Flask	Intact; same type as No. 6 (see Fig. 151); EI I
7	P 329	Flask	T. .055; same as No. 3 except for burnt umber 2 core
8	P 345	Bowl	Fine ware, few minute mixed grits, brown ocher 2, roman sepia 1 and light red 1 decoration (cf. <i>OIP</i> XLII, Pl. 30, No. 141)
9	P 326	Jug	Well made, permanent brown 3, indian red 3 wash, close vertical burnishing, blue-black 3 decoration (cf. <i>OIP</i> XLII, Pl. 6, No. 147)
TOMB 237			
10	P 370	Bowl	Intact, many large light grits, poorly made, brown ocher 2 surface. See Pl. 170:8 for photograph.
11	P 371	Bowl	Intact, many large light grits, brown ocher 3 surface. See Pl. 170:5 for photograph.
12	P 372	Jug	Many mixed grits, burnt umber 3 (see p. 159). See Pl. 170:6 for photograph.
13	P 373	Jar	Well fired, burnt umber 2, indian red 2 decoration (see p. 159). See Pl. 170:7 for photograph.

TOMB 221 B

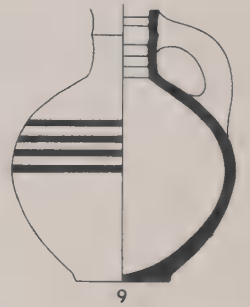
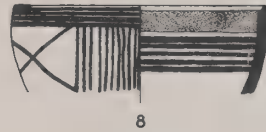
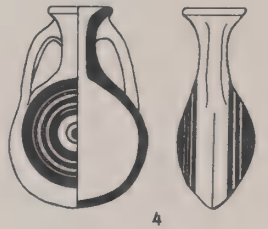
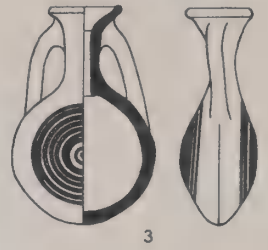
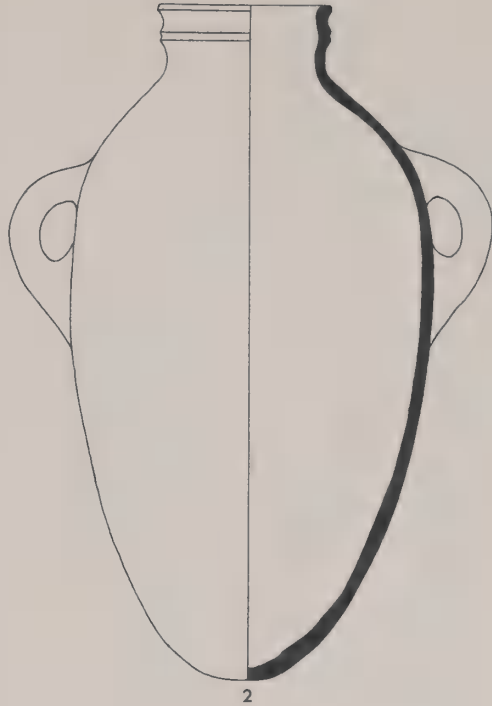
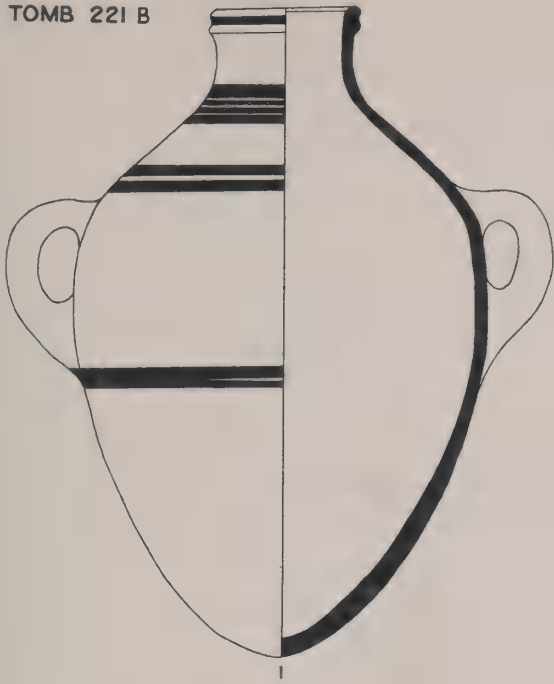

TOMB 237

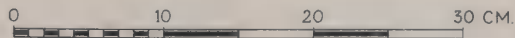
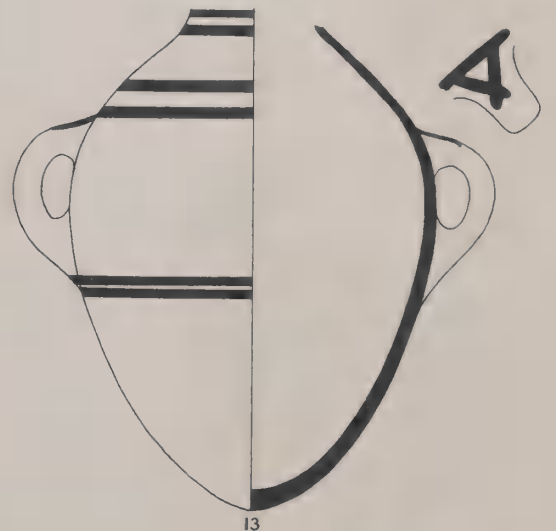
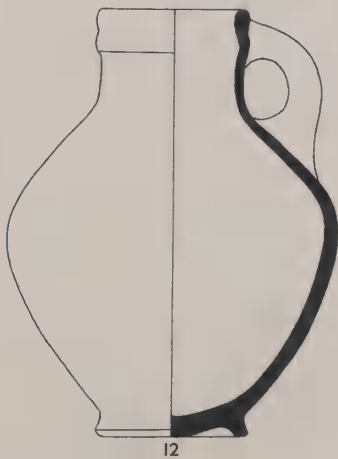

EI I POTTERY (Nos. 8-9 EI II) FROM TOMBS 221 B AND 237 (SEE PP. 125 F.). SCALE, 1:5

No.	Field No.	Designation	Description
TOMB 1090 A			
1	P 3824	Bowl	Complete, well fired, permanent brown 3 core, brown ocher 2 surface. See Pl. 170:9 for photograph.
2	P 3825	Bowl	Many mixed grits, brown ocher 2. See Pl. 170:13 for photograph.
3	P 3822	Bowl	Intact, well fired, brown ocher 2 surface, indian red 2 decoration. See Pl. 170:11 for photograph.
4	P 3820	Bowl	Well fired, blue-black 3 core, brown ocher 2 surface; badly warped. See Pl. 170:10 for photograph.
5	P 3828	Chalice	Many large light grits, poorly made, blue-black 3 core, brown ocher 3 surface (see p. 159)
6	P 3827	Bowl	Well fired, naples yellow 2. See Pl. 170:12 for photograph.
7	P 3826	Jar	Brown ocher 2 (see p. 159). See Pl. 170:14 for photograph.
8	P 3821	Flask	T. .055, many minute mixed grits, brown ocher 1, light red 2 decoration (see p. 159)
	P 3829	Flask	Same type as No. 8; EI I
9	P 5240	Flask	T. .080, many mixed grits, blue-black 3 core, brown ocher 3 surface, indian red 2 and blue-black 2 decoration (see p. 159)
10	P 3819	Jar	Many mixed grits, naples yellow 3 core, brown ocher 2 surface, traces of indian red 3 wash
	P 3823	Bowl	Complete; same type as No. 13 except for fine ware (see Fig. 158); EI I
TOMB 1090 B			
11	P 2767	Bowl	Many mixed grits, poorly made, blue-black 3 core, burnt umber 3 surface, traces of indian red 1 wash over rim
TOMB 1090 C			
12	P 2805	Bowl	Some large mixed grits, naples yellow 2 and blue-black 3 core, naples yellow 2 surface. See Pl. 170:16 for photograph.
13	P 2806	Bowl	Same as No. 12
14	P 2807	Lamp	Complete, many large mixed grits, blue-black 3 core, chiefly naples yellow 2 surface, lip blackened by fire. See Pl. 170:15 for photograph.

TOMB 1090 A

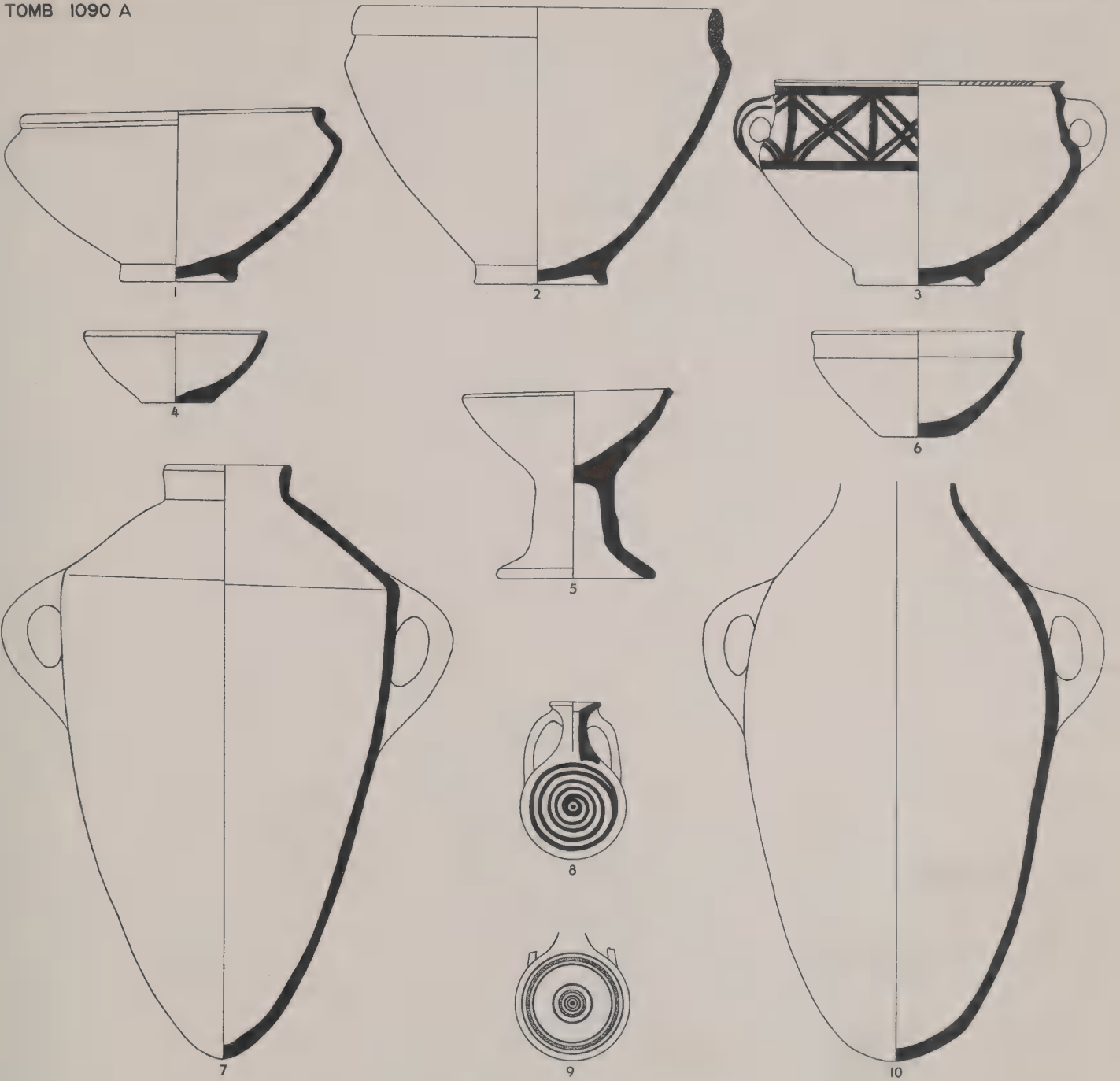

TOMB 1090 C

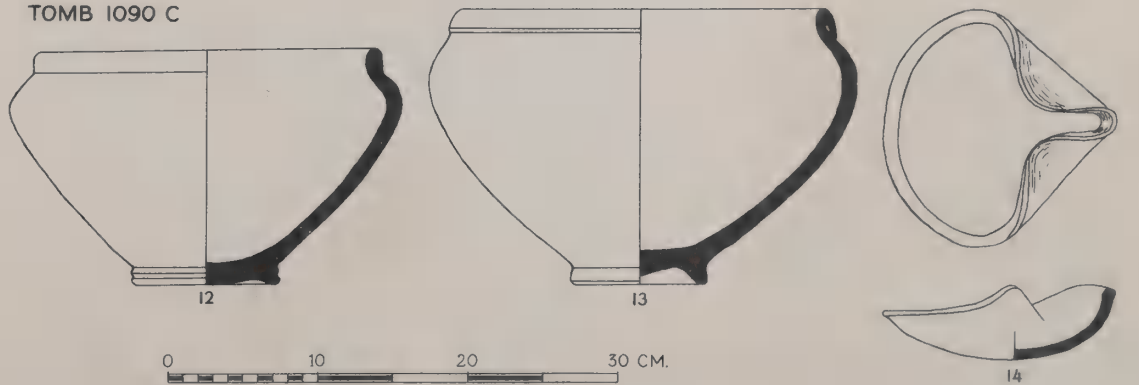

TOMB 1090 B

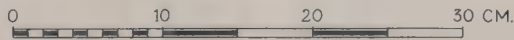

EI I POTTERY FROM TOMB 1090 (SEE P. 126). SCALE, 1:5

No.	Field No.	Designation	Description	Date
TOMB 27				
1	x 10	Jug	Poorly made, burnt umber 3	EI II
2	x 468	Jug	Permanent brown 3	EI II
3	x 467	Jug	Permanent brown 3	EI II
4	x 466	Jug	Permanent brown 3	EI II
TOMB 64				
5	P 18	Jug	Complete; same as No. 8 except for spaced vertical burnishing (cf. <i>OIP XLII</i> , Pl. 5, No. 120)	EI II
6	P 19	Jug	Complete; same as No. 5	EI II
7	P 17	Jug	Same as No. 8 except for burnt umber 3 core and no burnishing (cf. <i>OIP XLII</i> , Pl. 6, No. 157)	EI II
8	P 20	Bowl	Some minute light grits, mars yellow 3, chiefly burnt umber 3 wash, spaced horizontal burnishing	EI II
TOMB 47				
9	1763	Lamp	Brown ocher 3, traces of indian red 3 wash (cf. <i>OIP XLII</i> , Pl. 37, No. 11)	MI
10	3	Jar	Permanent yellow 3	MI
11	2	Jar	Coarse ware, permanent brown 3, naples yellow 3 slip (cf. <i>OIP XLII</i> , Pl. 16, No. 79)	MI
12	5	Bowl	Permanent brown 3, indian red 3 wash inside and over rim, wheel burnishing	MI
13	1	Jug	Brown ocher 3	MI
	1762	Lamp	Same type as Pl. 172:9 (see p. 127)	LI (Greek)
		Sherds		LB II and MI
TOMB 76 A				
14	P 204	Flask	T. .056, many large mixed grits, poorly made, brown ocher 3 core, burnt umber 3 surface, indian red 3 spiral decoration. See Pl. 172:12 for photograph.	EI I
15	4082	Flask	T. .057, near-burnt umber 3, indian red 3 spiral around ringed dot. See Pl. 172:13 for photograph.	EI I
16	P 226	Bowl	Burnt umber 3 (cf. <i>OIP XLII</i> , Pl. 31, No. 153). See Pl. 172:16 for photograph.	EI II
17	P 253	Bowl	Few minute mixed grits, well made, brown ocher 2 core, light red 1 slip, close irregular burnishing, blue-black 2 decoration; Cypriote (cf. <i>OIP XLII</i> , Pl. 29, No. 107)	E-MI
18	P 202	Jug	Intact, well fired, burnt umber 3 surface. See Pl. 172:17 for photograph.	EI II
19	P 225	Jug	Intact, well fired, burnt umber 2 surface, light red 2 wash, close vertical burnishing (cf. <i>OIP XLII</i> , Pl. 5, No. 130). See Pl. 172:18 for photograph.	EI II
20	P 203	Jug	Few mixed grits, sepia 2 core, blue-black 1 surface, traces of close vertical burnishing (cf. <i>OIP XLII</i> , Pl. 5, No. 126). See Pl. 172:19 for photograph.	E-MI
21	3522	Jug	Fine ware, many minute mixed grits, well made, well fired, brown ocher 2, light red 1 slip, close burnishing	EI II
22	P 201	Jug	Some minute mixed grits, lightly fired, brown ocher 2. See Pl. 172:20 for photograph.	MI?
23	P 209	Lamp	Lightly fired, sepia 2 core, brown ocher 2 surface, traces of light red 2 wash. See Pl. 172:14 for photograph.	E-MI
24	P 221	Lamp	Same as No. 23 except for many mixed grits and well fired	E-MI
25	P 227	Chalice	Lightly fired, chiefly blue-black 3 core, burnt umber 3 surface (cf. <i>OIP XLII</i> , Pl. 33, No. 20). See Pl. 172:15 for photograph.	EI II
TOMB 76 B				
26	4308	Chalice	Lightly fired, permanent brown 3 core, naples yellow 2 surface, traces of light red 3 wash	MI?

TOMB 27

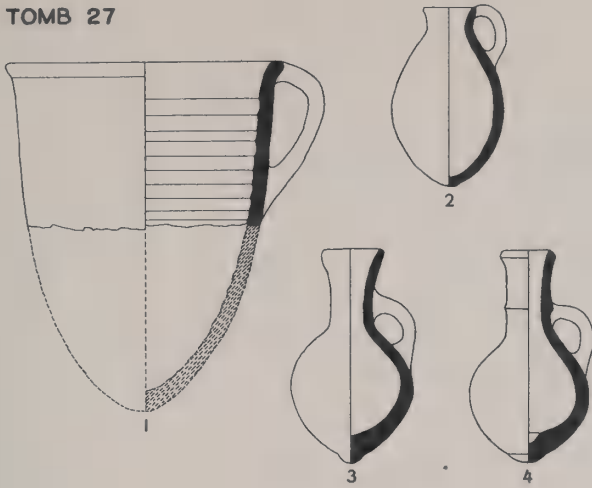

TOMB 64

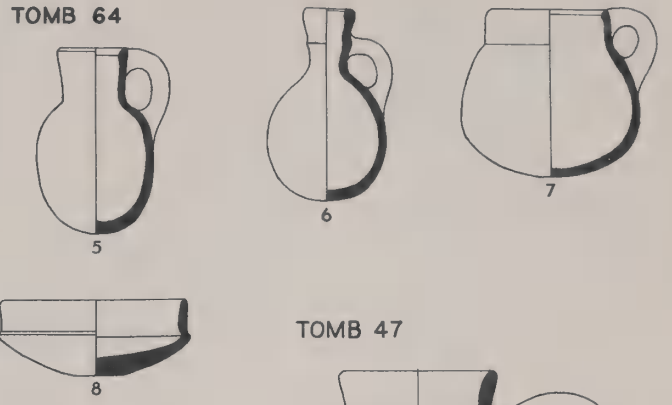

TOMB 47

TOMB 47

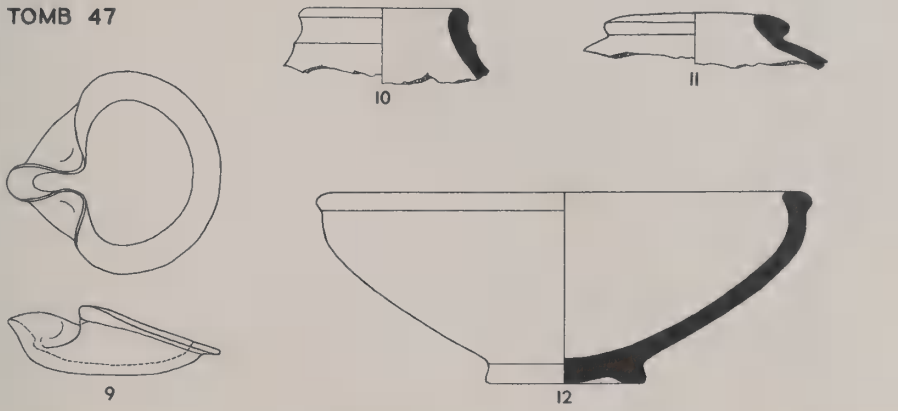

TOMB 76 A

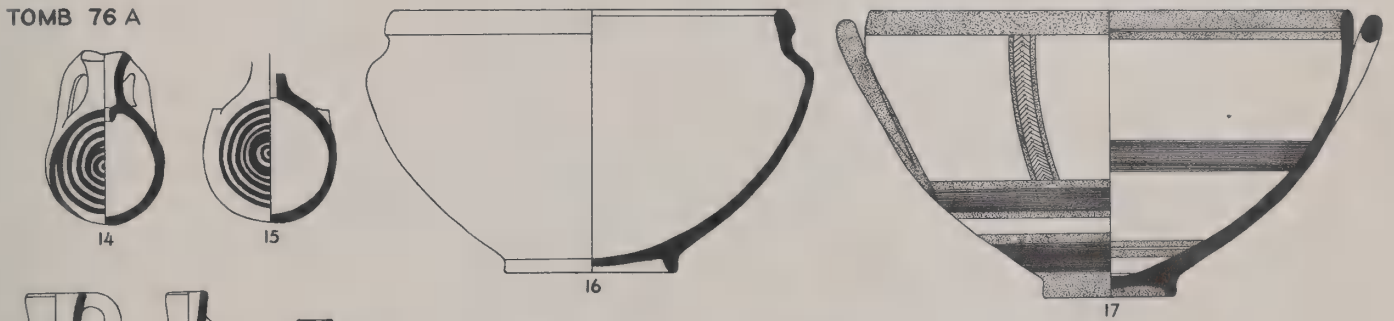

TOMB 76 B

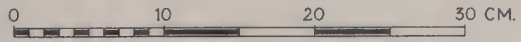
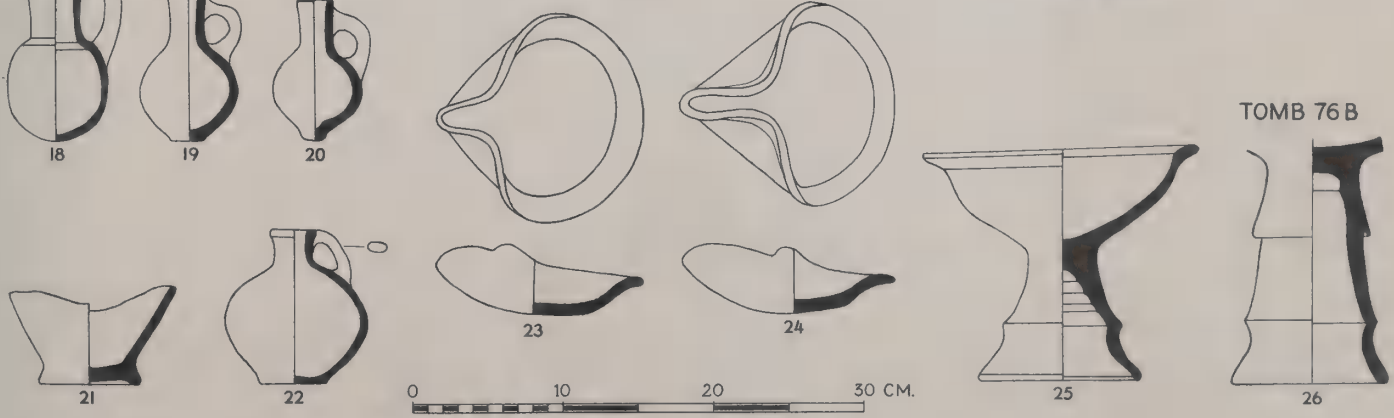

IRON AGE POTTERY FROM TOMBS 27, 64, 47, AND 76 (SEE P. 127). SCALE, 1:5

No.	Field No.	Designation	Description	Date*
TOMB 80				
1	3535	Bowl	Coarse ware, few dark grits, poorly made, lightly fired, roman sepia 1 core, permanent brown 3 surface, light red 2 wash and irregular hand burnishing inside and over rim, handmade (cf. <i>OIP XLII</i> , Pl. 26, No. 81)	MI
2	3534	Jar-stand	Same as No. 1 except for imprints of cloth binding outside	MI
3	4103	Bowl	D. .40, permanent brown 3 core, naples yellow 1 outside surface, light red 1 wash inside and over rim, lattice burnishing inside	Stages I-IV. Col. 1 E
TOMB 80 A				
4	4099	Stirrup cup	Fine ware, some minute mixed grits, well made, well fired, naples yellow 1, close horizontal burnishing, light red 1 decoration; Mycenaean. See Pl. 174:11 for photograph.	LB II
5	P 492	Bowl	Well fired, blue-black 3 core, naples yellow 2 surface. See Pl. 174:10 for photograph.	LB II
6	4102	Bowl	Fine ware, few minute mixed grits, well made, well fired, black lead 3 core, naples yellow 1 outside surface, light red 1 wash inside and over rim, close irregular horizontal burnishing	EI II
7	4101	Bowl	Fine ware, chiefly permanent brown 1 core, brown ocher 1 wash, close irregular burnishing	EI II
		Jar	Hole-mouth	?
TOMB 80 C				
8	P 491	Bowl	Fine ware, some minute mixed grits, very well made, brown ocher 2, indian red 3 wash inside and over rim, horizontal burnishing outside and over rim, close ring burnishing on base, indian red 3 decoration on base (cf. <i>OIP XLII</i> , Pl. 25, No. 57). See Pl. 175:1 for photograph.	E-MI
		Bowls (ca. 10)	Same type as No. 8	E-MI
9	4115	Bowl	Same as No. 8	E-MI
10	P 314	Cooking bowl	Many mixed grits, well made, well fired, blue-black 3 core, burnt umber 1 surface. See Pl. 174:15 for photograph.	E-MI
11	P 315	Cooking bowl	Many mixed grits, well made, burnt umber 1 (cf. <i>OIP XLII</i> , Pl. 39, Nos. 9 and 11-12). See Pl. 174:16 for photograph.	E-MI
12	3560	Jar	Some large mixed grits, well fired, permanent brown 3 core, brown ocher 2 surface	E-MI
13	P 490	Chalice?	Well made, well fired, brown madder 3 and brown ocher 3 core, brown ocher 2 surface, indian red 2 wash (stippled in drawing), blue-black 3 decoration; impossible to reconstruct. See Pl. 175:2 for photograph.	E-MI
14	P 494	Cover	Some dark grits, chiefly sepia 3 core, naples yellow 2 inside surface, light red 3 wash outside, spaced horizontal burnishing. See Pl. 174:13 for photograph.	E-MI†
15	P 316	Cover	Same as No. 14. See Pl. 174:14 for photograph.	E-MI†

\* "Stages" do not date a given piece but indicate the duration of its type. See *SAOC* No. 10, pp. 52-65 and chart.

† See *OIP XLII*, "Pottery Types," § 71.

TOMB 80



TOMB 80 A

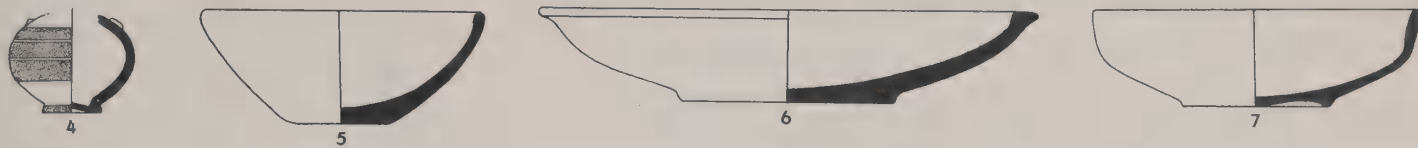

TOMB 80 C

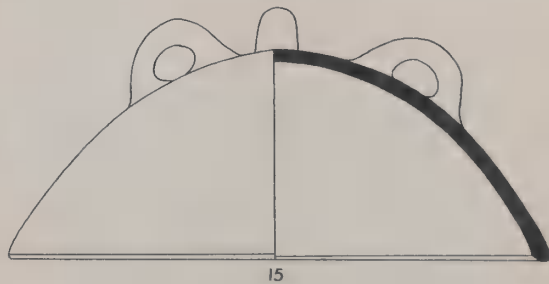
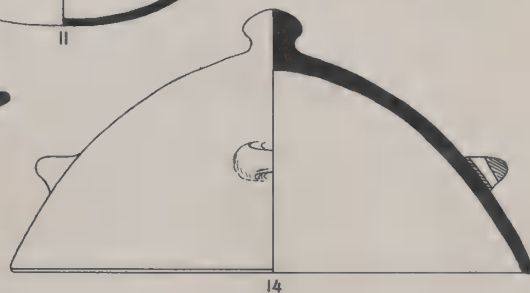
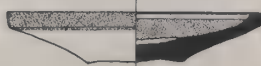
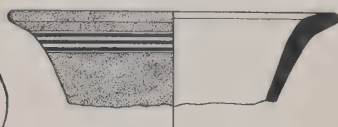
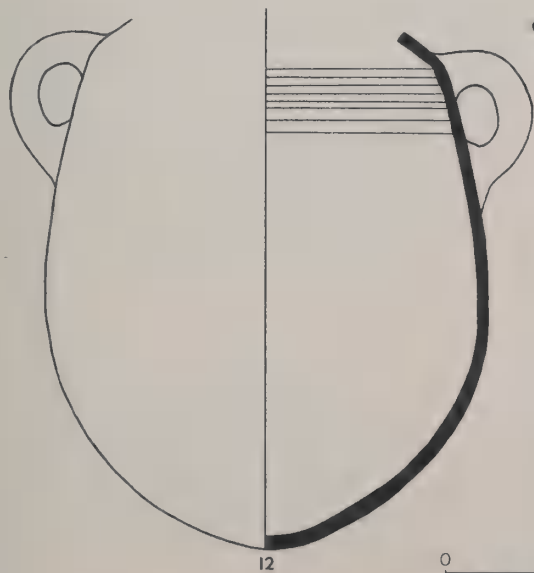
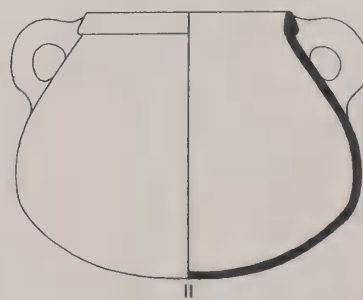
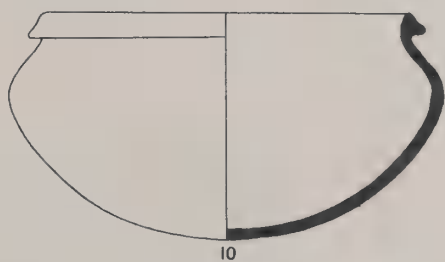
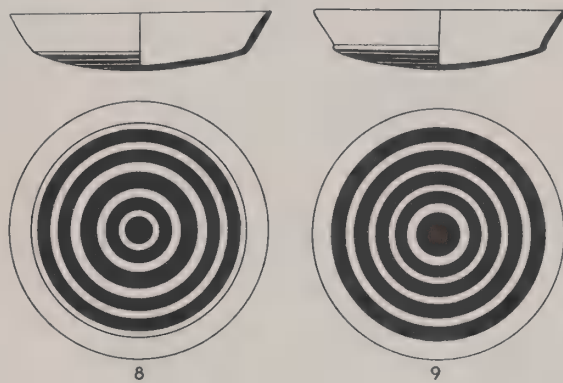

POTTERY FROM TOMB 80 (SEE PP. 127 AND 129). SCALE, 1:5

No.	Field No.	Designation	Description	Date*	
TOMB 903 UPPER (STAGES IV-V)					
1	P 3579	Bowl	See Pl. 3:4	Stages III-IV. Col. 22 <i>B</i>	
2	P 3576	Jar	See Pl. 3:7	Stages IV-VII. Col. 26	
3	M 2519	Flint	T. .010	Stages IV-V	
4	M 2601	?	Copper (see p. 161 for analysis)	Stages IV-V	
5	M 2555	Macehead or loom weight	Intact, t. .025, basalt (see p. 170)	Stages IV-V	
6	M 2635	Macehead or loom weight	Intact, t. .020, basalt (see p. 170)	Stages IV-V	
7	M 2520	Figurine	Pottery, blue-black 2; animal head	Stages IV-V	
TOMB 903 LOWER (STAGES V-VII)					
8	P 4545	Bowl	See Pl. 3:10	Stages IV-VII. Col. 20 <i>A</i>	
9	P 4544	Bowl	See Pl. 3:11	Stages IV-VII. Col. 20 <i>A</i>	
10	P 4540	Bowl	See Pl. 3:31	Stages IV-VII. Col. 18 <i>A</i>	
11	P 4541	Bowl	See Pl. 3:32	Stages IV-VII. Col. 18 <i>A</i>	
12	P 4487	Bowl	See Pl. 3:33	Stages IV-VII. Col. 13 <i>A</i>	
13	P 4486	Jar	See Pl. 3:36	Stages III-VII. Col. 12 <i>N</i>	
14	P 4530	Jar†	See Pl. 3:34	Stages IV-VII. Col. 23 <i>C</i>	
15	P 4531	Jug	See Pl. 3:49	Stages IV-VII. Col. 23 <i>B</i>	
16	P 4529	Jug	See Pl. 3:46	Stages IV-VII. Col. 24	
17	M 3622	Macehead or loom weight	Basalt (see p. 170)	Stages V-VII	
18	M 3637	?	T. .023, limestone, incised decoration	Stages V-VII	
19	M 3562	?	T. .011, bone	Stages V-VII	
	M 3673	Macehead or loom weight	Same type as No. 6	Stages V-VII	
	M 3674	Rubber	Limestone	Stages V-VII	
	M 3418-19 M 3563 M 3623	Shells		Stages V-VII	
			Grinders (2)	Basalt (cf. Fig. 127; see p. 170)	Stages V-VII

\* "Stages" for pottery vessels indicate duration of types (see *SAOC* No. 10, pp. 52-65 and chart). Other objects are dated by their pottery context.

† Spout glued on upside down.

TOMB 903 UPPER



TOMB 903 LOWER



CHALCOLITHIC OBJECTS FROM TOMB 903 (SEE PP. 9-12). SCALE, POTTERY VESSELS 1:5; OTHER OBJECTS ACTUAL SIZE

No.	Field No.	Description	Date*
1	P 5254	Some minute light grits (calcite), permanent brown 3 core, brown ocher 2 inside surface, indian red 2 wash	Stages III-V. Col. 14 C
2	P 5252	Many minute dark grits, naples yellow 2, indian red 1 wash	Stages IV-VII. Col. 14 G
3	P 5256	Many mixed grits (calcite), permanent brown 3 core, naples yellow 3 surface	Stages IV-VII. Col. 14 H
4	P 5249	Some mixed grits (calcite), brown ocher 2 core, naples yellow 3 inside surface, indian red 2 wash	Stages IV-VII. Col. 14 G
5	P 5250	Many light grits, brown ocher 2 core, burnt umber 3 surface	Stages IV-VII. Col. 14 G
6	P 5253	Same as No. 2 except for calcite grits and indian red 2 wash	Stages IV-VII. Col. 14 H
7	P 5255	Same as No. 4 except for darker core	Stages IV-VII. Col. 14 G
8	P 4535	No grits visible, poorly made, naples yellow 3	Stages III-V. Col. 14 D
9	P 5248	Calcite grits, naples yellow 2, indian red 2 to light red 1 trickle wash	Stages IV-VII. Col. 14 G
10	P 5251	Some light grits (calcite), brown ocher 2 core, naples yellow 2 inside surface, light red 3 wash	Stages IV-VII. Col. 14 F-G
11	P 5257	Brown ocher 3 core, naples yellow 2 surface	Stages IV-VII. Col. 14 G
12	P 5238	D. .31, some light grits, well made, well fired, black lead 1 core, black lead 3 surface, close horizontal burnishing; gray burnished ware (see p. 143)	Stage VII. Col. 17 C
13	P 5268	Coarse ware, many mixed grits (calcite), blue-black 3 core, naples yellow 2 inside surface, indian red 1 wash, crude rope decoration	Stages IV-V. Col. 15 A
14	P 5239	Many light grits (calcite), brown ocher 3 core, naples yellow 2 surface, purple madder 3 to light red 3 trickle wash	Stages VI-VII. Fig. 8 K-M†
15	P 5242	Some mixed grits (calcite), brown ocher 3, faded vandyke brown 3 grain wash	Stages III-VII. Fig. 8 F-J†
16	P 5241	Blue-black 3 and brown ocher 3 core, burnt umber 3 surface, light red 1 grain wash	Stages III-VII. Fig. 8 F-J†
17	P 5243	Same as No. 15 except for roman sepia 1 grain wash	Stages III-VII. Fig. 8 F-J†
18	P 5244	Same as No. 14 except for roman sepia 1 grain wash	Stages III-VII. Fig. 8 F-J†
19	P 5245	Same as No. 15 except for blue-black 3 grain wash	Stages III-VII. Fig. 8 F-J†
20	P 5247	Many mixed grits, brown ocher 2, indian red 3 grain wash	Stages III-VII. Fig. 8 F-J†
21	P 4534	Many minute mixed grits (calcite), well fired, brown ocher 1 core, naples yellow 2 surface, raised rope decoration	Stage V. Col. 15 C
22	P 5272	Same as No. 23 except for permanent brown 3 core	Stage V. Col. 15 C
23	P 5269	Many minute mixed grits (calcite), blue-black 3 core, naples yellow 2 surface, raised rope decoration	Stage V. Col. 15 C
24	P 5271	Many minute light grits (calcite), brown ocher 2 core, naples yellow 2 surface, raised rope decoration	Stage V. Col. 15 C
25	P 5274	Same as No. 23 except for brown ocher 2 core and light red 3 wash	Stage V. Col. 15 C
26	P 5275	Same as No. 23 except for brown ocher 3 core and light red 3 wash	Stage V. Col. 15 C
27	P 5276	Same as No. 23 except for permanent brown 3 core and light red 3 wash	Stage V. Col. 15 C
28	P 5277	Many minute light grits (calcite), brown ocher 2, faded indian red 3 wash, raised rope decoration	Stage V. Col. 15 E

\* "Stages" do not date a given piece but indicate the duration of its type. See SAOC No. 10, pp. 52-65, Fig. 8, and chart.

† In SAOC No. 10.

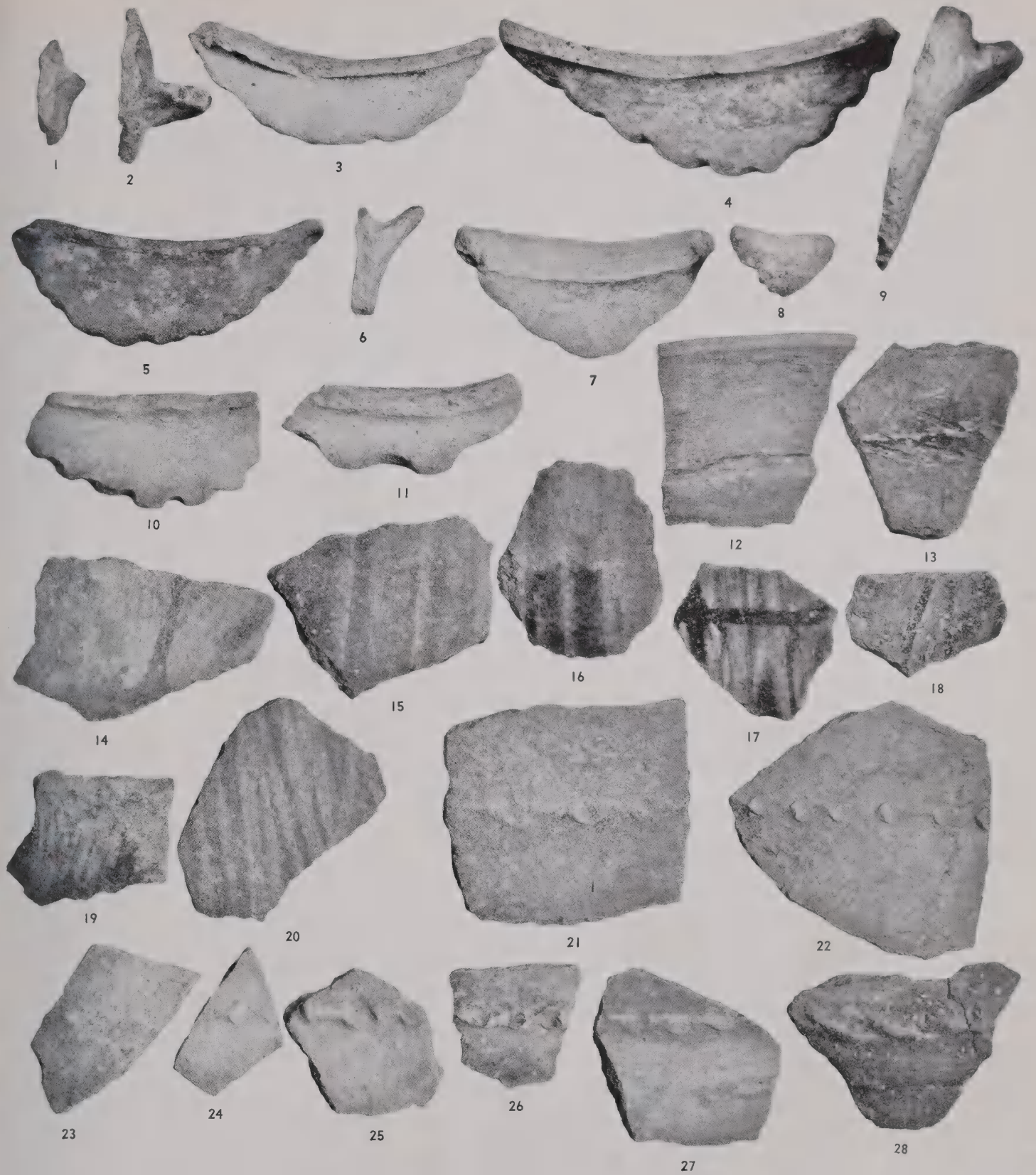

CHALCOLITHIC JAR SHERDS (No. 12 BOWL SHERD) FROM TOMB 903 LOWER (SEE PP. 9-12), ALL HANDMADE. SCALE, 2:5

No.	Field No.	Designation	Description	Date*
1	P 5270	Jar	Same as No. 2	Stages IV-V. Col. 15 A
2	P 5273	Jar	Many minute mixed grits (calcite), brown ocher 2 core, naples yellow 2 surface, light red 3 trickle wash, raised rope decoration	Stage VI. Col. 15 F
3	P 5278	Jar	Many minute mixed grits (calcite), permanent brown 1 core, brown ocher 2 surface, traces of light red 2 wash, raised rope decoration	Stage V. Col. 15 C
4	P 5280	Jar	Same as No. 2 except for modified rope decoration on rim	Stage VI. Col. 15 G
5	P 5279	Jar	Few minute mixed grits (calcite), permanent brown 3 core, naples yellow 3 inside surface, faded indian red 3 trickle wash outside and over rim, vertical raised rope decoration	Stages III-VII. Col. 12 N
6	P 5281	Jar	Rim d. .28, few minute mixed grits (calcite), brown ocher 2 core, naples yellow 2 surface, incised decoration on rim	Stages IV-VII. Col. 12 E
7	P 5228	Bowl	See Pl. 3:19	Stages IV-VII. Col. 19 A
8	P 5226	Bowl	D. .31, some minute mixed grits, naples yellow 2, indian red 1 wash, incised decoration	Stages IV-VII. Col. 19 A
9	P 5285	Bowl	D. .35, some minute dark grits, well fired, brown ocher 2, indian red 2 wash outside and over rim; mending hole	Stages IV-VII. Col. 13 A
10	P 5267	Jar	Some minute mixed grits (calcite), brown ocher 2 core, naples yellow 2 surface, imprint of rope binding	Stage VII. Col. 15 J
11	P 4533	Jug	Rim d. .07, many minute dark grits, brown ocher 2 core, naples yellow 2 surface, indian red 3 wash outside and over rim	Stages IV-VII. Col. 23 D
12	P 5303 a	Jug	Same as No. 24	Stages IV-VII. Col. 23 D
13	P 5294	Jar	Some minute dark grits, brown ocher 2	Stages IV-VII. Col. 23 C
14	P 5293	Jar	Same as No. 24 except for brown ocher 2 surface	Stages IV-VII. Col. 23 B
15	P 5295	Jar	Same as No. 24 except for light red 2 wash outside and over rim	Stages IV-VII. Col. 23 B
16	P 5297	Jar	Same as No. 24	Stages III-VII. Col. 25 B
17	P 5296	Jar	Same as No. 24 except for indian red 2 wash	Stages IV-VII. Col. 23 B
18	P 5300	Jar	Same as No. 24 except for indian red 2 wash and burnishing	Stages V-VI. Col. 9 F
19	P 5301	Jar	Same as No. 24 except for indian red 2 wash and burnishing	Stages V-VI. Col. 9 F
20	P 5298	Jar	Same as No. 24 except for indian red 2 wash outside and over rim	Stages IV-VII. Col. 26
21	P 5299	Jar	Same as No. 24 except for indian red 2 wash outside and over rim	Stages IV-VII. Col. 24
22	P 5291	Chalice?	Some minute light grits, blue-black 3, close horizontal burnishing; gray burnished ware	Stages IV-VII
23	P 4542	Bowl	D. .27, many minute dark grits, davy's gray 2, close horizontal burnishing outside and over rim	Stages VI-VII. Col. 18 B
24	P 4528	Jar	Many dark grits, brown ocher 2 core, naples yellow 2 surface, light red 1 wash outside, incised decoration	Stages V-VI. Col. 9 F

\* "Stages" do not date a given piece but indicate the duration of its type. See SAOC No. 10, pp. 52-65 and chart.



CHALCOLITHIC POTSDHERDS FROM TOMB 903 LOWER (SEE PP. 9-12), ALL HANDMADE. SCALE, 2:5

No.	Field No.	Description	Thickness
1	M 3619	Sickle, double serrations and polish on upper edge, lower edge blunted	.008
2	M 3560	Sickle, intact(?), double serrations and polish on upper edge	.005
3	M 3763	Sickle, intact, double serrations and polish on upper edge, lower edge blunted	.004
4	M 3766	Sickle, intact, double serrations and polish on upper edge	.004
5	M 3765	Saw, single serrations on upper edge, partially crusted	.007
6	M 3559	Borer	.005
7	M 3620	Blade	.005
8	M 3555	Utilized blade, upper edge blunted, lower edge polished	.007
9	M 3667	Utilized flake, polished, partially crusted	.008
10	M 3561	Sickle	.004
11	M 3557	Blade, tip retouched	.006
12	M 3558	Utilized blade	.006
13	M 3413	Sickle	.005
14	M 3417	Utilized blade	.007
15	M 3416	Sickle	.005
16	M 3412	Sickle, intact(?)	.005
17	M 3764	Utilized blade	.005
18	M 3411	Utilized blade, worn serrations on upper edge	.005
19	M 3415	Utilized flake, worn serrations on lower edge	.006
20	M 3556	Utilized blade, partially crusted	.005
21	M 3407	Utilized blade	.007
22	M 3762	Blade, intact, upper edge polished	.010
23	M 3761	Utilized blade, worn serrations and polish on upper edge, lower edge serrated and polished	.007
24	M 3760	Utilized blade, both edges serrated	.006
25	M 3410	Blade, intact, partially crusted	.004
26	M 3420	Utilized blade, partially crusted	.004

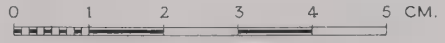

CHALCOLITHIC (STAGES V-VII) FLINT IMPLEMENTS FROM TOMB 903 LOWER (SEE PP. 9-12). ACTUAL SIZE

No.	Field No.	Description	Thickness
1	M 3405	Utilized blade, serrated	.007
2	M 3406	Utilized blade, partially crusted	.009
3	M 3414	Utilized blade	.007
4	M 3409	Sickle, both edges polished, partially crusted	.007
5	M 3408	Sickle, worn serrations and polish on both edges	.006
6	M 3757	Flake	.010
7	M 3666	"Neolithic" pick, some crust on both sides, polished	.015
8	M 3554	Flake, polish and accidental serrations on working edge	.022
9	M 3758	Scraper, upper edge retouched as protection for index finger, lower edge sharp	.009
10	M 3621	Scraper, single serrations and polish	.014
11	M 3759	Scraper, worn single serrations and polish on lower edge	.008



CHALCOLITHIC (STAGES V-VII) FLINT IMPLEMENTS FROM TOMB 903 LOWER (SEE PP. 9-12). ACTUAL SIZE

No.	Field No.	Designation	Description	Date*
TOMB 910 A ROCK (STAGES V-VI)				
1	P 5026	Jar	Some minute dark grits (calcite), roman sepia 2 core, burnt umber 3 inside surface, light red 2 wash outside and over rim	Stages IV-V. Col. 8 C
2	P 5304	Ledge handle	Blue-black 3 core, brown ocher 2 surface, light red 1 wash	Stages IV-VII. Col. 14 G
3	P 5303	Jar	Many mixed grits, lightly fired, permanent brown 3 core, naples yellow 3 surface, indian red 2 wash	Stages V-VI. Col. 9 F
4	P 5305	Jar	Many mixed grits, brown ocher 1 core, naples yellow 2 surface, purple madder 3 wash, raised rope decoration	?
5	P 5306	Jar	Many mixed grits, blue-black 3 core, naples yellow 3 surface, blue-black 3 grain wash	Stages III-VII. Fig. 8 F-J†
6	P 5302	Jar	Lightly fired, roman sepia 3 core, naples yellow 2 surface, indian red 2 wash	?
TOMB 910 G ROCK				
7	P 5309	Bowl	Rim d. .43, some mixed grits (calcite), blue-black 3 core, faded sepia and brown ocher wash outside and over rim	Stages IV-VII. Col. 13 A
	P 5308	Bowl	Gray burnished ware	Stages IV-VII. Col. 17 A
TOMB 910 A FILL				
8	P 5022	Jar	Some minute mixed grits, permanent brown 2 core, burnt umber 2 surface, pottery mark	Stages IV-V. Col. 12 H
9	P 5023	Ledge handle	Many minute mixed grits, burnt umber 3 core, chiefly indian red 3 wash, pierced vertically	Stages IV-VII. Col. 14 G
10	P 5020	Jar	Few mixed grits, well made, naples yellow 3, sepia 2 wash with red tint outside and over rim; spout broken away	Stages IV-VII. Col. 23 A
11	P 5024	Bowl	Coarse ware, many mixed grits, lightly fired, blue-black 3 core, naples yellow 2 surface, traces of indian red 3 wash	Stages IV-VI. Col. 27 B
12	P 5311	Jar	Many mixed grits, permanent brown 3 core, indian red 1 to burnt umber 2 grain wash	Stages III-VII. Fig. 8 F-J†
13	P 5312	Jar	Some dark grits, well fired, permanent brown 3 core, black 3 grain wash	Stages III-VII. Fig. 8 F-J†
14	P 5310	Jar	Fine ware, many minute mixed grits, well made, well fired, blue-black 3 core, burnt umber 2 inside surface, indian red 3 wash, vertical burnishing, wheelmade	Stage IV. Col. 21‡
15	P 5313	Ledge handle	Blue-black 3 core, indian red 2 wash, close horizontal burnishing	Stages V-VI. Col. 14 F
16	P 5314	Ledge handle	Same as No. 15	Stages III-V. Col. 14 E
TOMB 910 B FILL				
17	P 5317	Bowl	Rim d. .40, blue-black 3 core, indian red 1 wash outside and over rim, polished, rope decoration	Stages IV-VII. Col. 13 B
18	P 5319	Jar spout	Well made, permanent brown 3 core, naples yellow 3 inside surface, light red 1 wash, irregular burnishing	Stages IV-VII. Col. 23
19	P 5321	Jar	Same as No. 18 except for spaced crisscross burnishing; lug handle	Stages III-VII. Col. 25 B
20	P 5316	Jar	Naples yellow 2, light red 3 wash	Stages V-VI. Col. 9 F
21	P 5032	Jar leg	Coarse ware, many mixed grits, brown ocher 3 core, chiefly purple madder 1 grain wash	Stages III-VII. Fig. 8 F-J†
22	P 5322	Jar	Many mixed grits, blue-black 3 core, indian red 3 wash, raised rope decoration	Stage V. Col. 15 E
TOMB 910 C FILL				
23	P 5325	Jar	Rim d. .12, fine ware, permanent brown 3 core, naples yellow 2 surface, impressed decoration, wheelmade(?)	Stages I-IV. Col. 12 A
24	P 5033	Jar	Rim d. .16, few light grits, blue-black 3 core, roman sepia 3 surface, naples yellow 2 wash over rim, pottery mark	Stages I-III. Col. 12 B

\* "Stages" do not date a given piece but indicate the duration of its type. See SAOC No. 10, pp. 52-65, Fig. 8, and chart.

† In SAOC No. 10.

‡ See also SAOC No. 10, p. 19, n. 6.

TOMB 910 A ROCK



TOMB 910 A FILL

TOMB 910 G ROCK

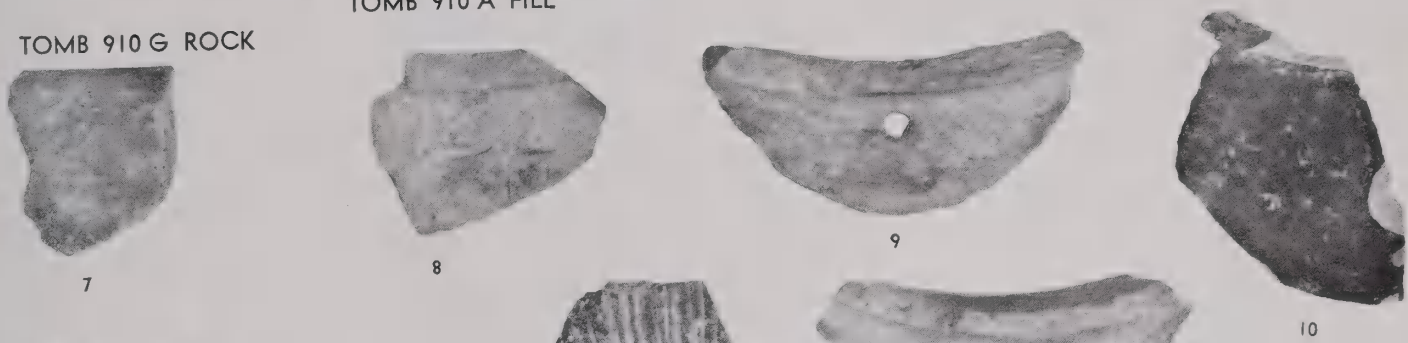

TOMB 910 A FILL

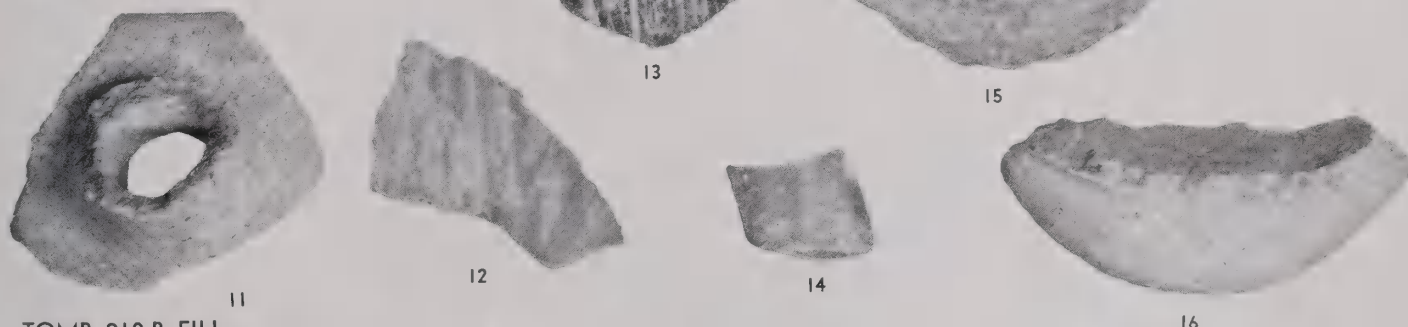

TOMB 910 B FILL

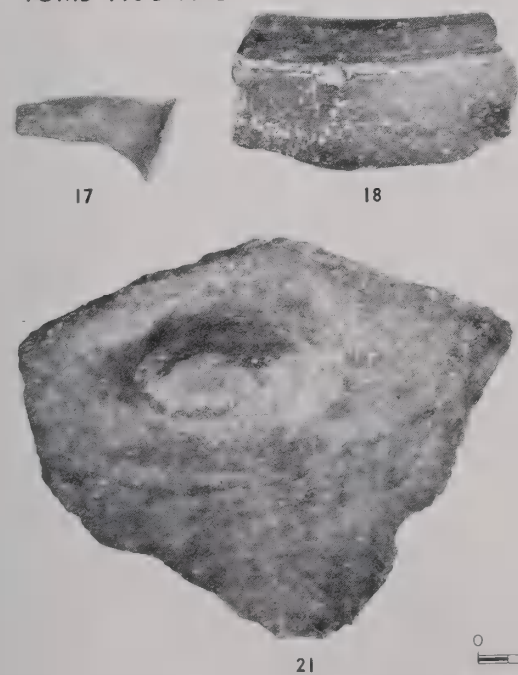

TOMB 910 C FILL

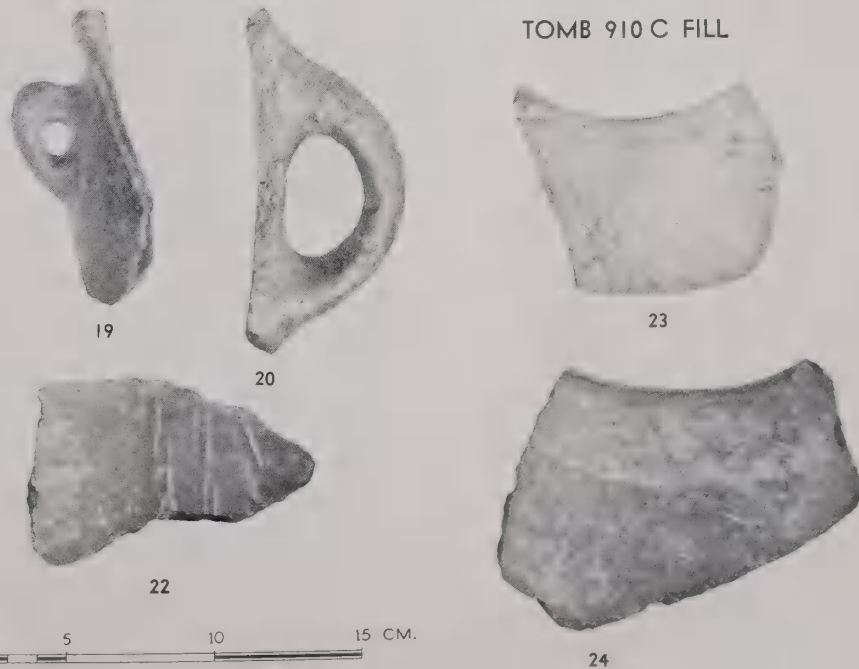

No.	Field No.	Designation	Description	Date*
TOMB 910 D FILL				
1	P 5329	Jar	Many light grits (calcite), brown ocher 2 core, indian red 2 wash, traces of burnishing	Stages V-VI. Col. 9 <i>F</i>
2	P 5330	Ledge handle	Same as No. 1 except for no burnishing	Stages V-VI. Col. 14 <i>F</i>
3	P 5331	Ledge handle	Many minute mixed grits, blue-black 3 core, brown ocher 2 surface	Stages III-V. Col. 14 <i>D</i>
4	P 5037	Ledge handle	Same as No. 1	Stages III-V. Col. 14 <i>C</i>
5	P 5036	Jar	Permanent brown 3 core, indian red 2 wash outside and over rim, impressed decoration	Stages IV-VII. Col. 12 <i>E</i>
6	P 5035	Jar	Many minute mixed grits, well made, permanent brown 3 core, light red 1 wash, spaced crisscross burnishing	Stage V. Col. 28 <i>F</i>
TOMB 910 E FILL				
7	P 5333	Jug	Some minute mixed grits, blue-black 3 core, naples yellow 2 inside surface, light red 1 wash, spaced irregular burnishing; spout broken away	Stages IV-VII. Col. 23 <i>B</i>
8	P 5041	Foot of vessel	Blue-black 3 core, naples yellow 2 surface, traces of light red 2 wash	?
TOMB 910 G FILL				
9	P 5044	Jar	Brown ocher 2 core, burnt umber 1 wash outside and over rim, pottery mark	Stages III-VII. Col. 12 <i>N</i>
10	P 5345	Jar	Naples yellow 2 core, brown ocher 3 surface, sepia 2 wash	Stages III-VII. Col. 12 <i>N</i>
11	P 5045	Jar	Same as No. 9 except for indian red 3 wash	Stages IV-V. Col. 12 <i>H</i>
12	P 5347	Jar	Same as No. 10 except for sepia 3 grain wash	Stages III-VII. Fig. 8 <i>F-J</i> †
13	P 5342	Jug	Same as No. 15; tip of spout broken	Stages IV-VII. Col. 23 <i>C</i>
14	P 5336	Ledge handle	Naples yellow 2 core, blue-black 1 to burnt umber 2 wash, burnished	Stages IV-VII. Col. 14 <i>H</i>
15	P 5337	Ledge handle	Naples yellow 2 core, indian red 2 wash	Stages IV-VII. Col. 14 <i>G</i>
16	P 5338	Ledge handle	Same as No. 15 except for burnishing	Stages IV-VII. Col. 14 <i>G</i>

\* "Stages" do not date a given piece but indicate the duration of its type. See SAOC No. 10, pp. 52-65, Fig. 8, and chart.

† In SAOC No. 10.

TOMB 910 D FILL

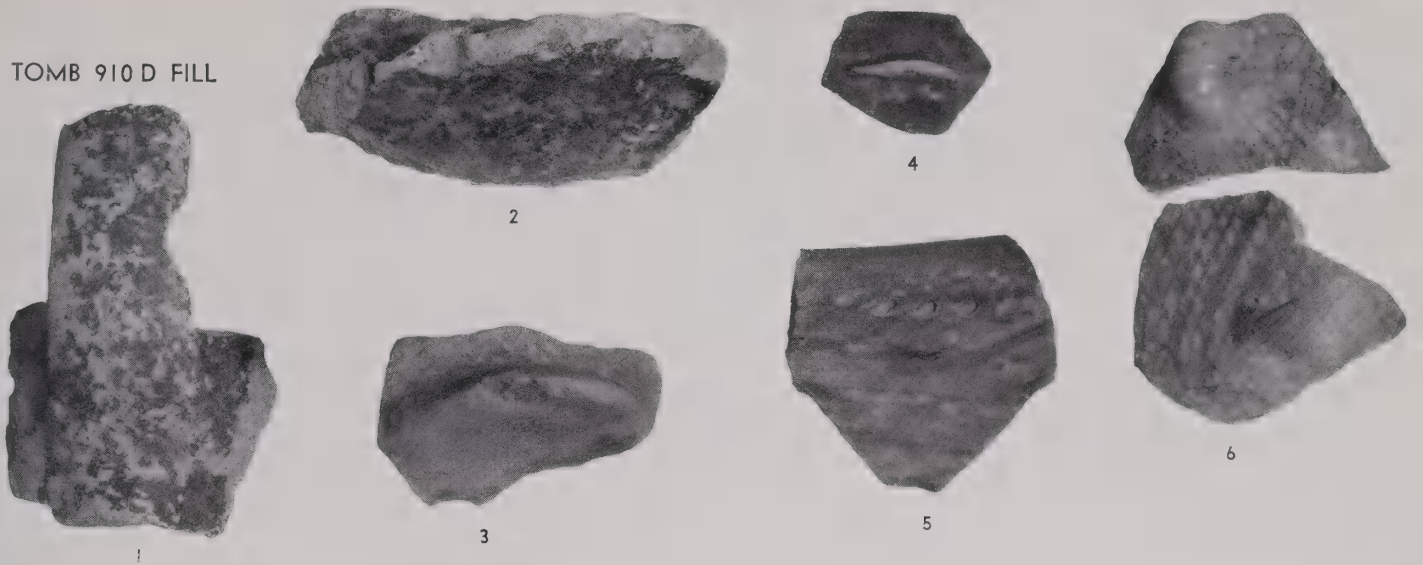

TOMB 910 E FILL

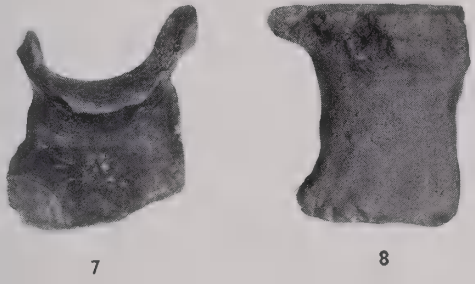

TOMB 910 G FILL

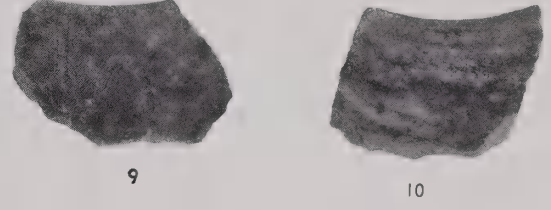

TOMB 910 G FILL

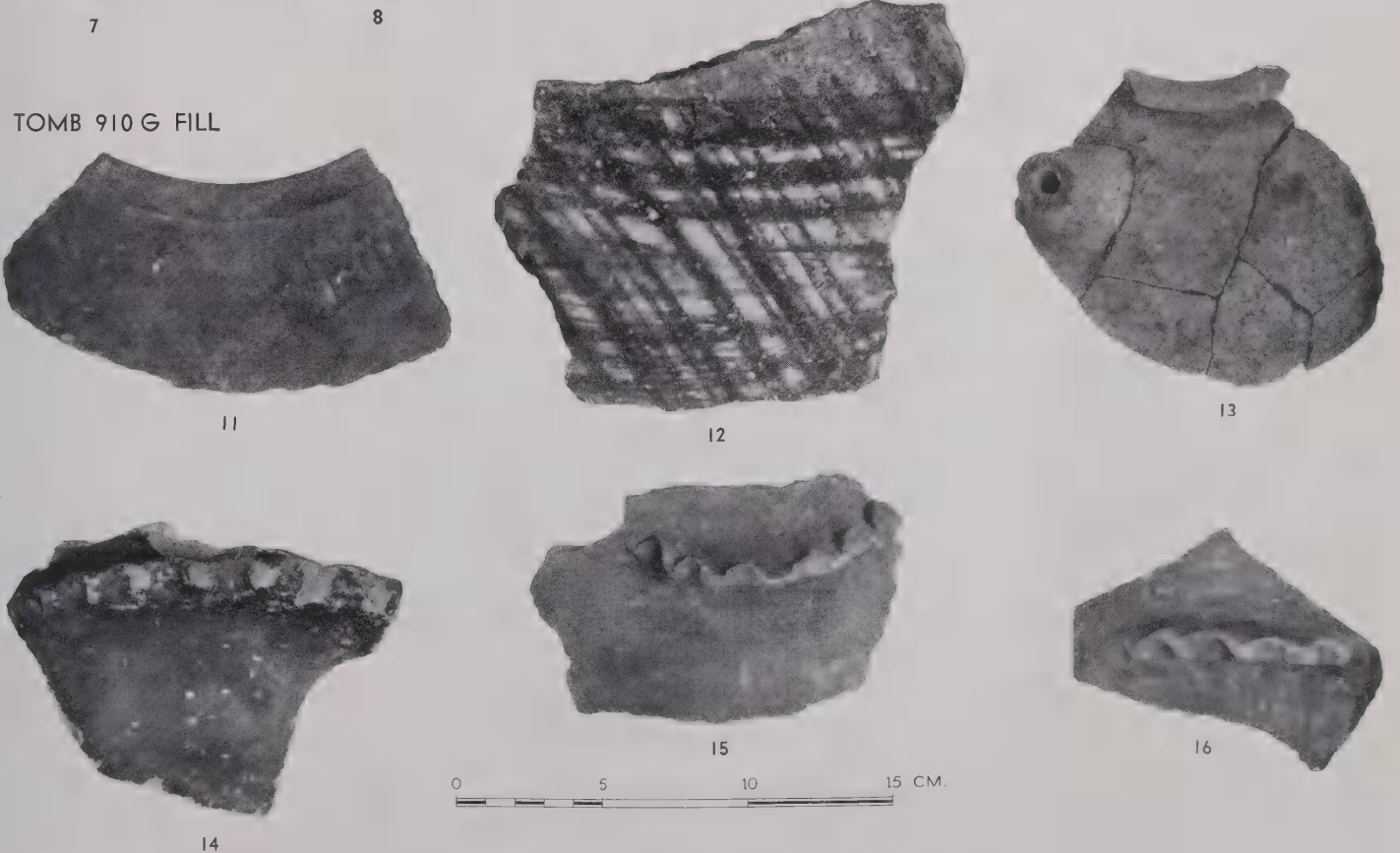

No.	Field No.	Designation	Description	Date*
			TOMB 910 A FILL	
1	P 3770	Jar	See Pl. 4:13	Stages I-III. Col. 12 C
			TOMB 910 D FILL	
2	P 4910	Jar	See Pl. 4:22	Stages IV-VII. Col. 14 G
			TOMB 910 E UPPER	
3	P 5038	Jar	See Pl. 4:30	?
			TOMB 1103	
4	M 3373	Flint Sherds	Intact, t. .007, double serrations on both edges	Stages IV-V? Stages IV-V
			TOMB 1122 SHELF	
5	M 3524	Bowl	Intact, .116×.105×.045 high, limestone, crudely made	Stages IV-VII
6	M 3537	Flint	T. .004, worn double serrations on right edge	Stages IV-VII

\* "Stages" for pottery indicate duration of types (see SAOC No. 10, pp. 52-65 and chart). Other objects are dated by their context.

TOMB 910 A FILL



1

TOMB 910 D FILL

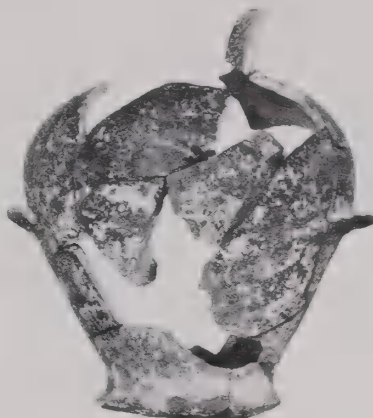

2

TOMB 910 E UPPER



3

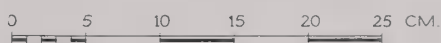

TOMB 1103



4

TOMB 1122 SHELF

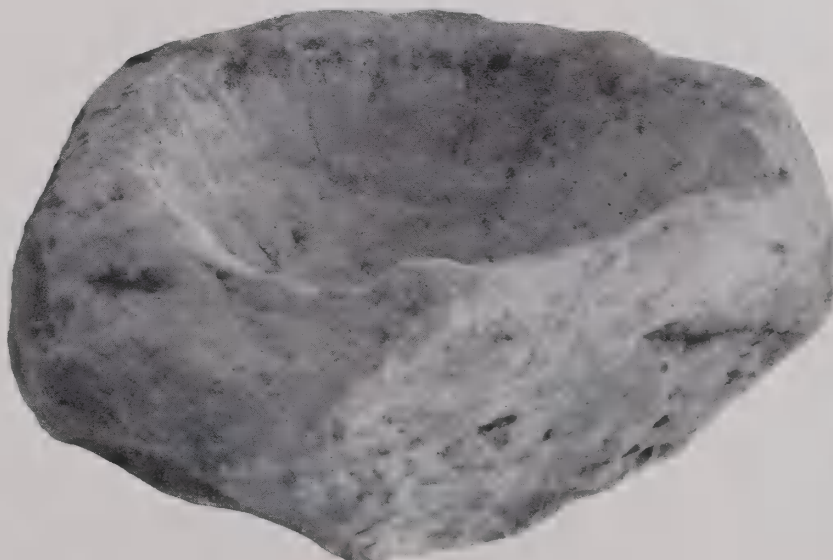

5

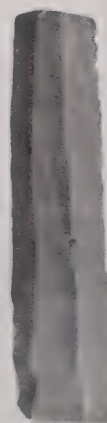

6

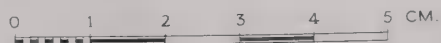

OBJECTS FROM TOMBS 910, 1103, AND 1122 SHELF (SEE PP. 12 AND 17-20).  
SCALE, POTTERY 1:5; OTHER OBJECTS ACTUAL SIZE

No.	Field No.	Designation	Description	Date
TOMB 1122 UPPER				
1	M 3568	Whorls and spindle	Bone; the mounting of the whorls on the spindle is reconstructed from M 3530,* which was found thus <i>in situ</i> : a pin passed through the whorls into holes in the spindle (Fig. 175:6)	LB II
2	M 3569	Spindles	Bone; the one directly above the number is hollowed out at each end	LB II
3-6	M 3574	Whorls	Intact, t. .006, bone, convex (see Fig. 175:8 for drawing of No. 4)	LB II
7	M 3584	Whorl	Intact, t. .011, bone, convex	LB II
8	M 3585	Whorl	T. .010, bone, convex, incised decoration (Fig. 175:10)	LB II
9	M 3587	Whorl	Intact, t. .008, bone, convex, incised decoration (Fig. 175:9)	LB II
10-14	M 3576	Whorls	T. .007 (Nos. 10-12) and .008 (Nos. 13-14), bone, concave (see Fig. 175:14 for drawing of No. 12); No. 14 has secondary piercing and was perhaps reused as a button	LB II
15	M 3588	Whorls	Intact, steatite, convex (Fig. 175:7)	LB II
16	M 3590	Pin	Intact, "bronze"	LB II
TOMB 1128				
17	M 3447	Bead	Carnelian, long cylinder	Probably Stage IV
18	M 3448	Bead	Carnelian, long cylinder	Probably Stage IV
19	M 3449	Bead	Intact, carnelian, short barrel	Stage IV
20	P 4051	Bowl	See Pl. 5:12	Stage IV
21	P 4048	Bowl	See Pl. 5:13	Stage IV
22	P 4050	Bowl	See Pl. 5:11	Stage IV
23	P 4045	Jar	See Pl. 5:8	Stage IV
24	P 4047	Jug	See Pl. 5:9	Stage IV
25	P 4046	Jug	See Pl. 5:10	Stage IV
	M 3450	Flint	Double serrations and polish on both edges	Stage IV?

\* Found in square U 17, Locus 1140.

TOMB 1122 UPPER

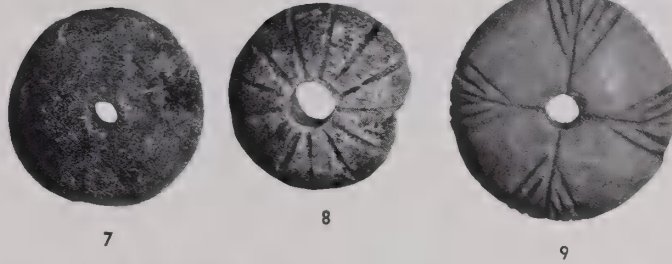
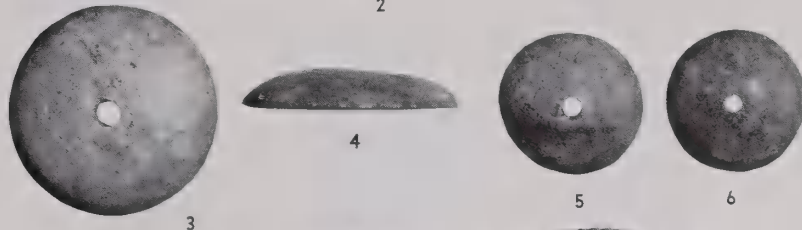

TOMB 1128

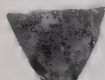
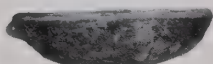
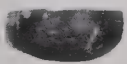
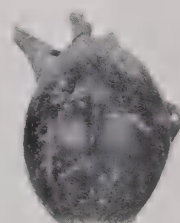
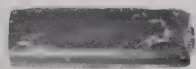

20

21

22

23

24

25

OBJECTS FROM TOMBS 1122 UPPER AND 1128 (SEE PP. 18-20). SCALE, POTTERY 1:5; OTHER OBJECTS ACTUAL SIZE

No.	Field No.	Designation	Description	Date*
TOMB 52				
1	1797	Jar	See Pl. 6:4	Stages I-III. Col. 5 A
2	x 1895	Bowl	Brown ocher 3, indian red 2 wash inside and over rim, handmade	Probably Stages I-IV
3	x 1796	Bowl	See Pl. 6:1	Probably Stages I-III. Cf. Col. 6
4	x 1902	Jug	See Pl. 6:6	LB II
5	x 1901	Jug	See Pl. 6:7	MI
6	x 1899	Whorl	Limestone	?
7	x 1897	Star?	Pottery, brown ocher 3, light red 3 wash	?
8	x 1898	Figurine	Pottery, naples yellow 3; animal	Stages I-III? (see p. 22)
9	1802	Wheel	Pottery, some dark grits, naples yellow 3, indian red 3 decoration	MI?
TOMB 1101 A LOWER				
10	M 3536	Flint	Intact, t. .004, single serrations on upper edge, double serrations on lower edge, both edges polished	Stage 0-I
TOMB 1102 LOWER				
11	P 4482	Jar	See Pl. 7:13	Stage 0-I. Col. 14 AA
12	M 3792	Macehead or loom weight	Intact, t. .024, basalt	Stage 0-I
13	M 3794	Flint	T. .005, double serrations and polish on lower edge	Stage 0-I
14	M 3793	Flint	T. .005, double serrations and polish on upper edge, lower edge blunted, both ends trimmed	Stage 0-I
TOMB 1101 B LOWER				
15	M 3535	Drill-socket	Basalt	Stage 0-I
16	P 4123	Bowl	See Pl. 6:22	Stage 0-I
17	P 4135	Bowl	See Pl. 6:23	Stage 0-I
18	P 4120	Jar	See Pl. 6:29	Stage 0-I
19	P 4122	Jar	See Pl. 6:31	Stage 0-I

\* "Stages" for pottery indicate duration of types (see SAOC No. 10, pp. 52-65 and chart). Other objects are dated by their context.

TOMB 52



TOMB 1101 A LOWER

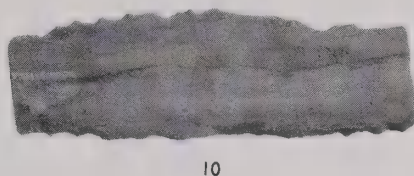

TOMB 1102 LOWER



TOMB 1101 B LOWER

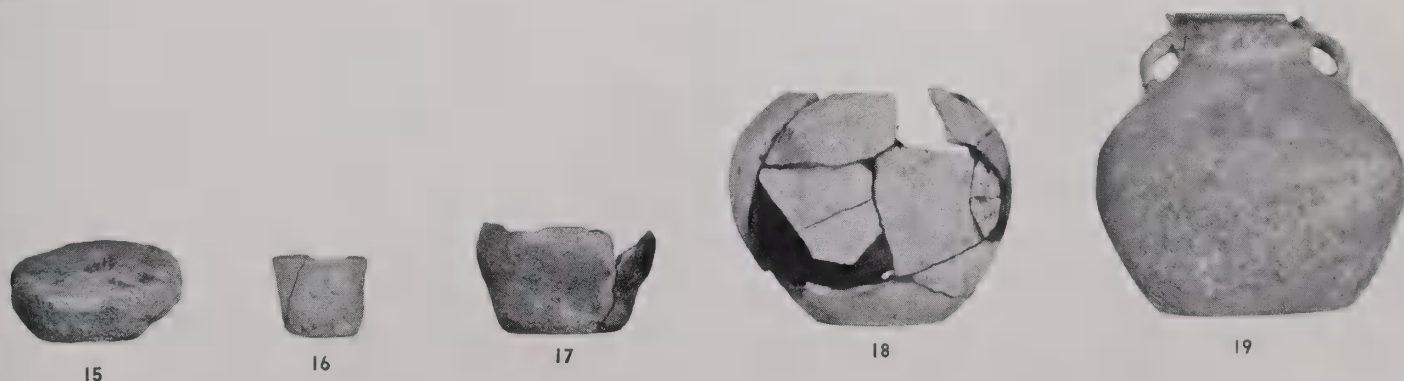

OBJECTS FROM TOMBS 52 AND 1101-2 (SEE PP. 20 AND 24-27). SCALE, 1:5 EXCEPT NOS. 10 AND 12-14, WHICH ARE ACTUAL SIZE

No.	Field No.	Designation	Description
1	M 3636	Spearhead	T. .004, copper (Fig. 170:2; see p. 161 for metal analysis)
2	M 3634	Toggle pin	Intact, copper (Fig. 174:1; see p. 161 for metal analysis)
3	M 3538	Spearhead	Intact, copper (see p. 161 for analysis), socketed but not ribbed (Fig. 170:1)
4	M 3539	Dagger blade	Intact, t. .005, copper (see p. 161 for analysis), 4 rivets for attachment to haft (Fig. 171:1)
5	M 3635	Kohl-stick	Intact, copper (see p. 161 for analysis)
6	M 3639	Ring	Intact, copper (Fig. 176:1; see p. 161 for metal analysis)
7	M 3534	Figurine	Intact, t. .020, pottery, naples yellow 2, pierced through middle of back, small hole in tail; sheep(?)

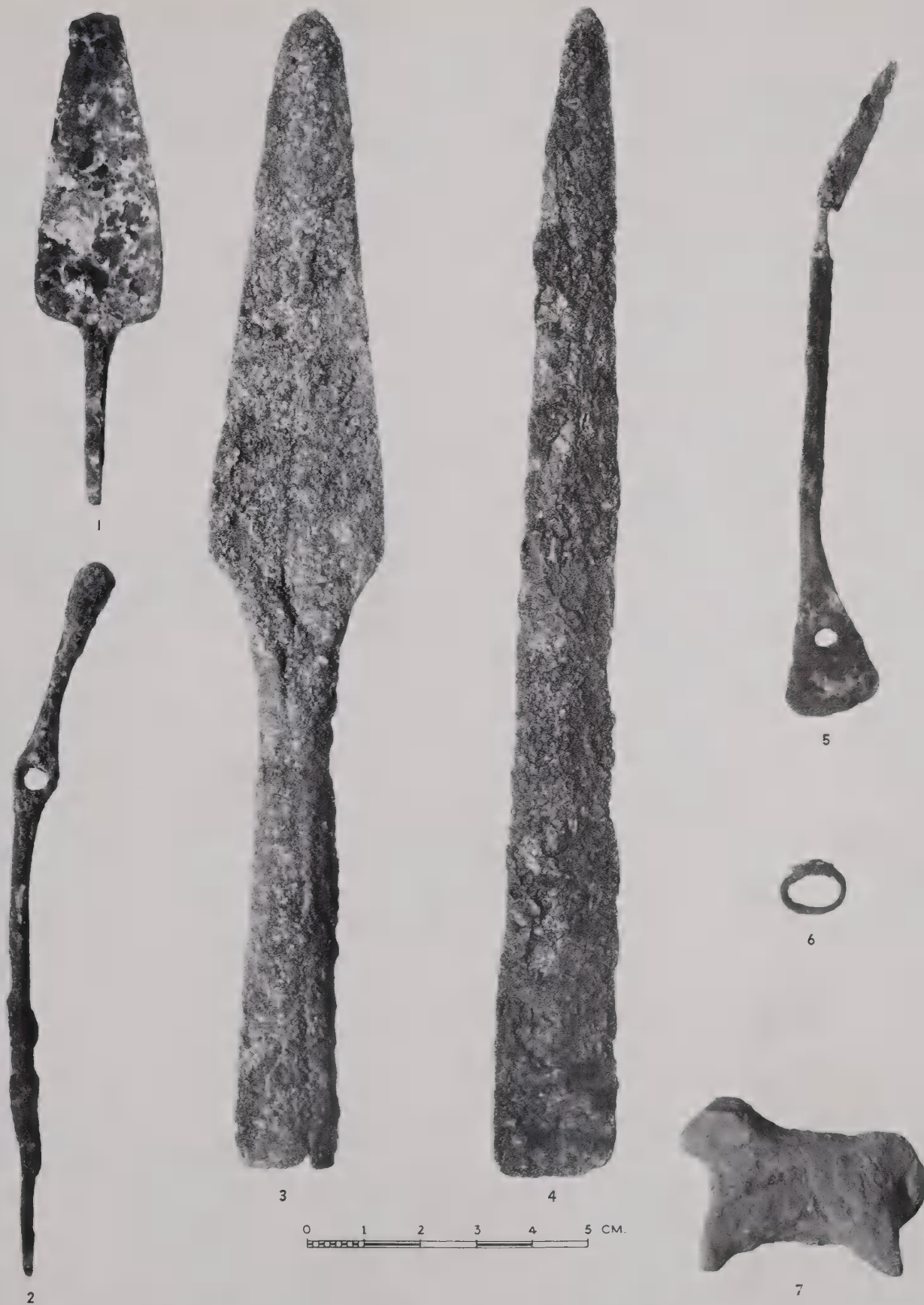

EB (STAGE 0-I) OBJECTS FROM TOMB 1101 B LOWER (SEE PP. 24-27). ACTUAL SIZE

No.	Field No.	Designation	Description
TOMB 1101 A UPPER			
1	M 3529	Jar	Egyptian "alabaster," vertically pierced horizontal loop handles, rim broken off and edge worked even for secondary use (Fig. 184:12)
2	P 4089	Jar	See Pl. 8:1
TOMB 1101 B UPPER			
3	P 4099	Bowl	See Pl. 8:8
4	P 4102	Jug	See Pl. 8:12
5	M 3532	Dagger blade	.30×.025×.005, iron, 3 rivets for attachment to haft; probably intentionally mutilated or "killed" (Fig. 171:14; see also p. 162)
6	M 3533	Disk	Ivory
7	P 4100	Bowl	Some large light grits, blue-black 3 core, naples yellow 2 surface
8	P 4093	Bowl	See Pl. 8:6
9	P 4091	Bowl	See Pl. 8:5
TOMB 1102 UPPER			
10	P 4145	Bowl	See Pl. 9:4
TOMB 1101 C			
11	P 4114	Flask	Some minute mixed grits, naples yellow 2, indian red 2 spiral decoration

TOMB 1101 A UPPER

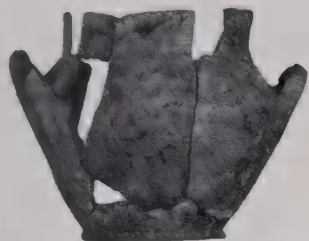

1

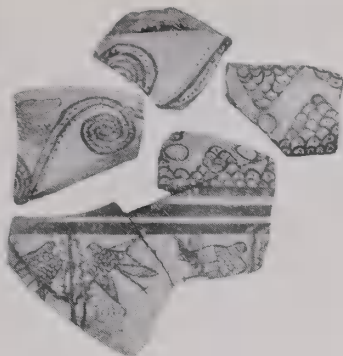

2

TOMB 1101 B UPPER



5

TOMB 1101 B UPPER

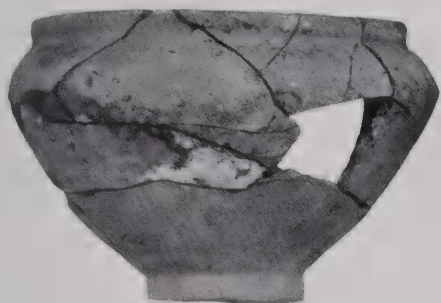

3

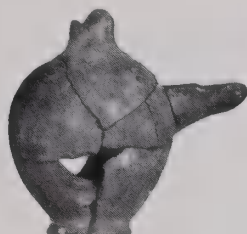

4

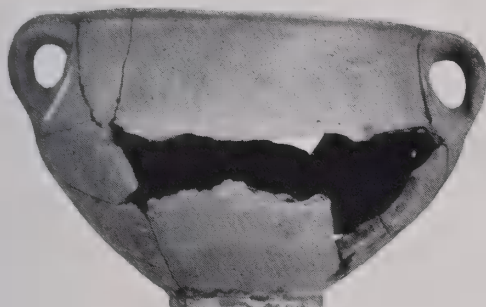

7

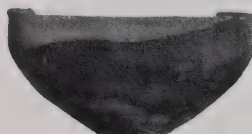

8



6

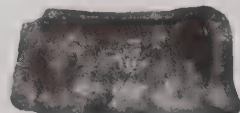

9

TOMB 1102 UPPER

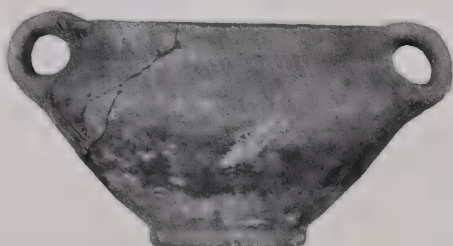

10

TOMB 1101 C



11

No.	Field No.	Designation	Description
TOMB 41			
1	x 802	Bowl	See Pl. 10:2
2	x 8	Bowl	Permanent brown 3
3	x 801	"Teapot"	See Pl. 10:5
4	x 803	"Teapot"	See Pl. 10:3
5	x 804	"Teapot"	See Pl. 10:4
6	x 0806 <i>b</i>	Jar	See Pl. 10:10
7	x 0806	Jar	See Pl. 10:9
8	816	Flint	T. .006
9	x 806	Whorl	Pottery, charcoal gray 3, drilling incomplete
TOMB 58			
10	x 2	Jar	Permanent yellow 3, handmade
11	2002	Jar	Brown ocher 3, indian red 1 wash outside and over rim, handmade
	x 5	Jar	Same type as No. 11; MB I
12	2975	Jar	Permanent yellow 3, rope decoration on shoulder, folded ledge handles, handmade
13	02974	Jar	Brown ocher 3, incised decoration on shoulder, handmade; one handle lost
	2973	Jar	Same type as No. 6; MB I
	2976	Jar	Same type as No. 7; MB I
TOMB 67 A			
14	5529	Whorl	Reused potsherd, permanent brown 3, burnished

TOMB 41



TOMB 58

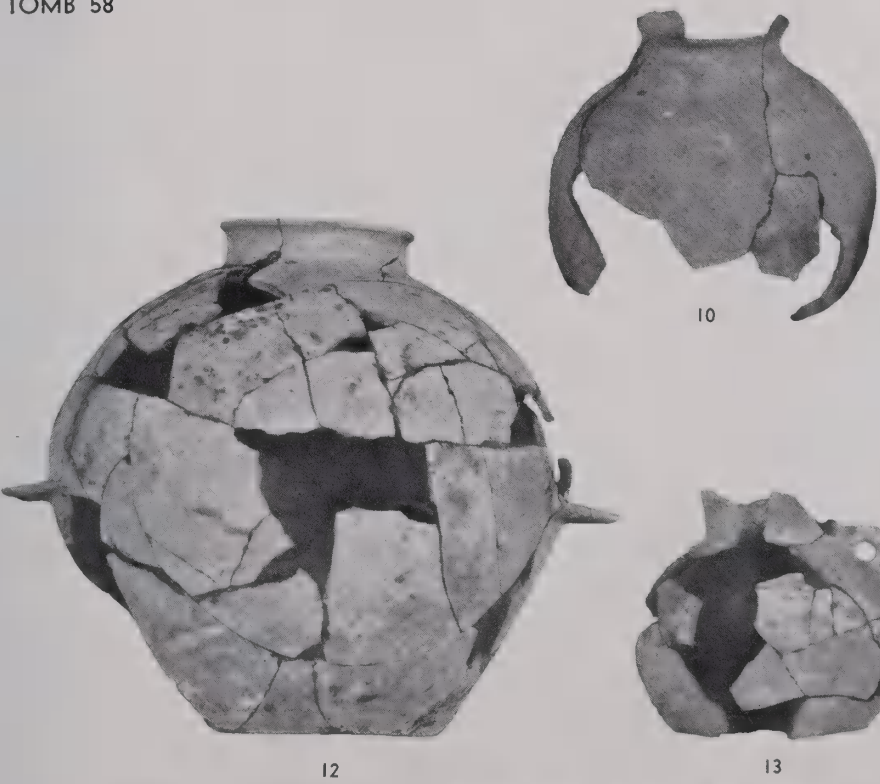

TOMB 67 A



MB I OBJECTS (Nos. 8-9 and 14 UNDATED) FROM TOMBS 41, 58, AND 67 A (SEE P. 291). SCALE, POTTERY VESSELS 1:5  
OTHER OBJECTS ACTUAL SIZE

No.	Field No.	Designation	Description	Date
1	M 615	Toggle pin	"Bronze," grooved decoration on head	LB I (cf. Fig. 174:7-9)
2	M 592	Arrowhead	T. .004, "bronze"	LB II? (cf. Petrie, <i>Gaza III</i> , Pl. IX 24)
3	M 598	Blade	T. .006, "bronze" (Fig. 173:4)	?
4	M 595	Bead	Intact, .024 long, pottery, burnt umber 1, standard barrel	?
5	M 596	Nail?	"Bronze," left end trifurcated	?
6	M 591	Dagger pommel	.029 high, ivory; "bronze" pin found in close association perhaps used for wedging the shaft	?
7	M 617 <i>b</i>	Flint	T. .005, upper edge serrated	?
8	M 617 <i>a</i>	Flint	T. .005, upper edge serrated	?
9	M 603	Knife blade	T. .004, "bronze," depression for inlay on either side of handle, coiled tip blunt (Fig. 172:7)	?
10	M 593	Plaque	T. .001, "bronze"	?
11	M 594	Figurine	T. .035, pottery, burnt umber 2; female	LB (cf. Pls. 99:2 and 139:25)
12	M 600	Dagger blade	T. .004, "bronze," square tang	LB II (cf. Fig. 171:11-13)

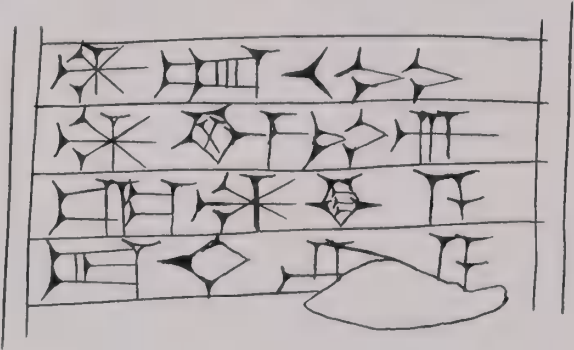

OBJECTS FROM TOMB 217 A (SEE P. 31). ACTUAL SIZE

No.	Field No.	Designation	Description	Scale
TOMB 217 A				
1	M 602	Adz head	T. .010, "bronze" (Fig. 173:6; cf. Petrie, <i>Tools and Weapons</i> , Pl. XVII 92)	1:1
2	M 599	Knife blade	"Bronze" (Fig. 172:8; cf. <i>ibid.</i> Pl. XXVIII 205)	1:1
3	M 614	Arrowhead	T. .003, "bronze," central rib	1:1
4	M 618	Gaming-piece?	Intact, pottery, burnt umber 3	1:1
5	M 597	Jug	"Bronze," trefoil spout (Fig. 186:10)	2:5
6	M 616 <i>b</i>	Bead	Intact, fayence, chromium oxide 3, long cylinder with one convex end	1:1
7	M 616 <i>a</i>	Bead	Intact, fayence, ultramarine ash 3, long truncated cone	1:1
8	M 590	Cylinder seal*	Composition or soft lapis lazuli, cerulean blue 3. The 2 figures appear to be deities in long fringed garments. One bears a scimitar typical of Marduk (cf. Ward, <i>The Seal Cylinders of Western Asia</i> , pp. 163-66 and Fig. 534), and the inscription increases the likelihood of the identification. There are 3 faun- or goatlike figures in various postures between the deities. The seal is neither Babylonian nor Assyrian. It closely resembles certain Nuzi seals except that the 2 men are bearded. Professor Chiera pointed out that the rather poor writing is a further feature which this seal has in common with the Nuzi type (see pp. 182-84). It was probably copied by someone ill versed in cuneiform from a Mesopotamian original which seems to have read as follows:	1:1
				
			<sup>4</sup> MES-umun-dim <sub>4</sub> dingir-sà-lá-sù sag-an-ki-a lu(?)-na(?)/LID-ni(?)-a O Marduk(?), great lord, merciful god, chief of heaven and earth . . . (perhaps a proper name).	
9	M 601	Knife blade	T. .004, "bronze," square tang (Fig. 172:9)	2:5
	M 604	Plate	D. .25, "bronze"; intentionally bent or "killed"	
TOMB 217 B				
10	P 269	"Teapot"	See Pl. 10:24	1:5
11	P 292	"Teapot"	Same as No. 13	1:5
12	P 293	"Teapot"	Same as No. 13	1:5
13	P 294	"Teapot"	Some dark grits, poorly made, well fired, permanent brown 3	1:5
14	P 295	"Teapot"	See Pl. 10:25	1:5
15	P 284	Jar	See Pl. 10:23	1:5
16	P 288	Jar	See Pl. 10:18	1:5
17	P 291	Jar	See Pl. 10:20	1:5
18	P 290	Jar	Some minute dark grits, well fired, burnt umber 3, traces of light red 3 wash	1:5
19	P 286	Bowl	See Pl. 10:16	1:5
20	P 352	Bowl	See Pl. 10:17	1:5
21	P 271	Lamp	See Pl. 10:28	1:5

\* Assigned tentatively to LB I on the basis of the inscription (see p. 182); the drawing of the inscription was made by E. R. Lacheman, formerly of the Oriental Institute.

TOMB 217 A

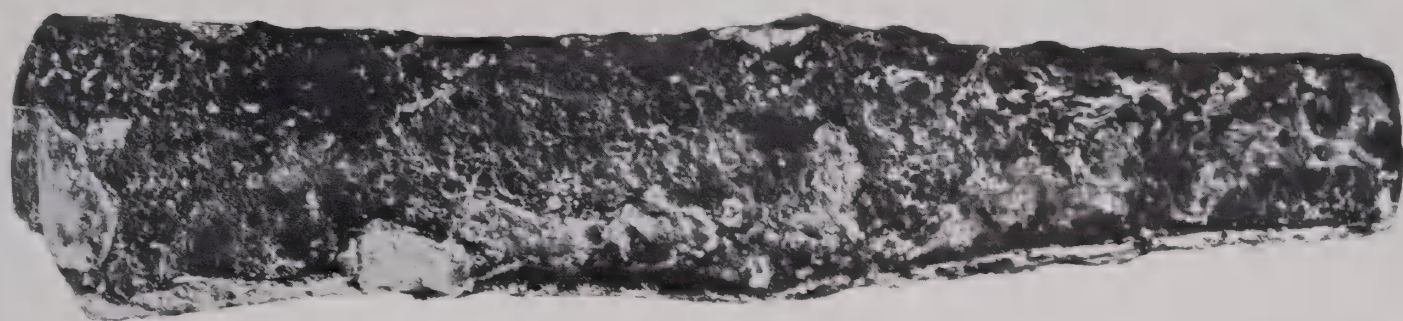

1

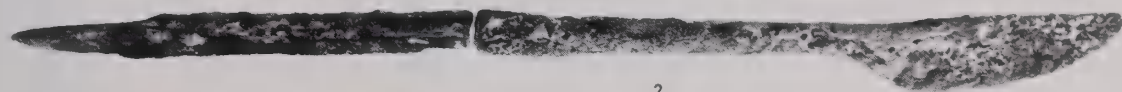

2

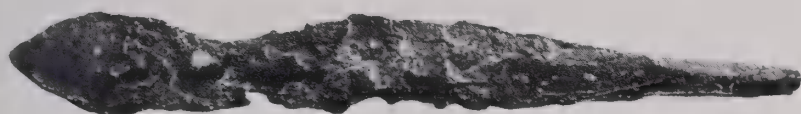

3



4



5



6



7

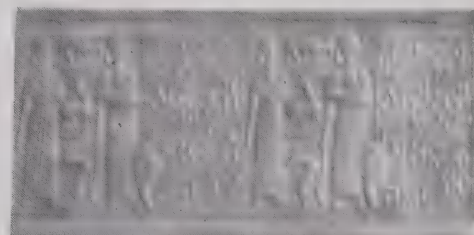

8

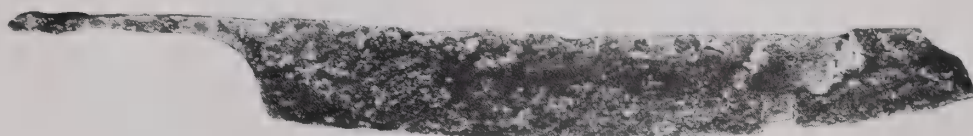

9

TOMB 217 B

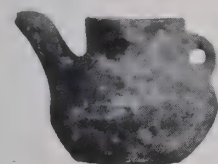

10

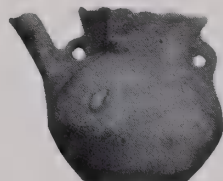

11

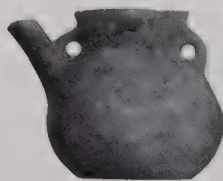

12



13

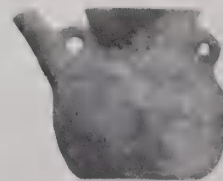

14

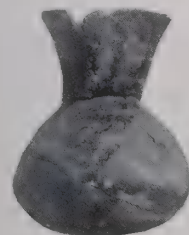

15

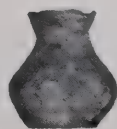

16



17



18



19

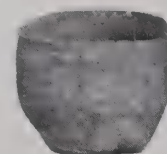

20

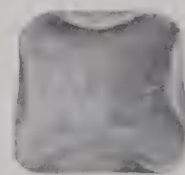

21

UNDATED OBJECTS FROM TOMB 217 A AND MB I POTTERY FROM TOMB 217 B (SEE P. 31)

No.	Field No.	Designation	Description	Date
TOMB 217 C				
1	P 353	Jar	See Pl. 11:10	LB I
2	P 273	Lamp	.061 high; same as No. 4	LB I
3	P 274	Lamp	Intact, .055 high; same as No. 4	LB I
4	P 275	Lamp	Intact, .054 high, some light grits, burnt umber 3	LB I
5	P 276	Lamp	See Pl. 11:18	LB I
6	P 285	Billbil	See Pl. 11:12	LB
7	P 287	Jug	See Pl. 11:16	LB II
8	P 270	Bowl	See Pl. 11:1	LB I
9	P 279	Bowl	See Pl. 11:2	LB I
10	P 280	Bowl	See Pl. 11:3	LB I
11	P 283	Bowl	See Pl. 11:4	LB I
12	P 272	Bowl	See Pl. 11:6	LB I
13	P 282	Bowl	Some light grits, sepia 3 core, burnt umber 3 surface	LB I
14	P 281	Bowl	See Pl. 11:7	LB II
TOMB 877 A 2				
15	P 2994	Jug	See Pl. 11:19	MB I
16	P 2993	Jug	See Pl. 11:20	MB I
17	P 2941	Jug	See Pl. 11:21	MB I
18	P 2939	Jug	See Pl. 11:24	MB I
19	P 2927	Jug	See Pl. 12:5	MB I
20	P 2933	"Teapot"	See Pl. 12:4	MB I
21	P 2943	"Teapot"	See Pl. 12:2	MB I
22	P 2930	"Teapot"	See Pl. 11:28	MB I
23	P 2932	"Teapot"	See Pl. 11:31	MB I
24	P 2936	"Teapot"	See Pl. 12:1	MB I
25	P 2940	"Teapot"	See Pl. 11:30	MB I
26	P 2990	"Teapot"	See Pl. 11:33	MB I
27	P 2928	Jar	See Pl. 12:6	MB I

TOMB 217 C

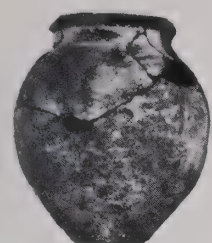

1

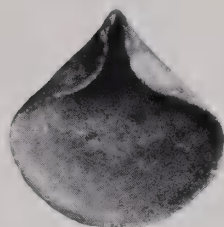

2

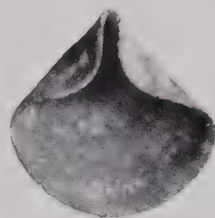

3

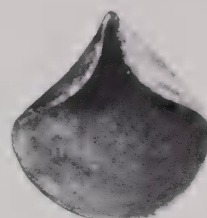

4

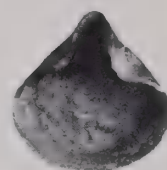

5



6



7

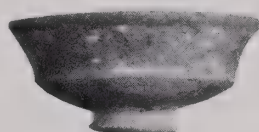

8



9

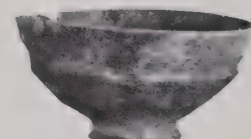

10

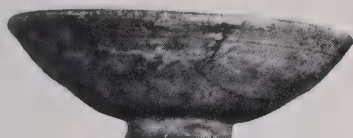

11

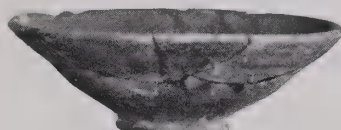

12



13

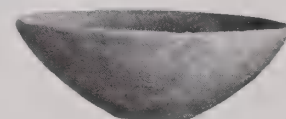

14

TOMB 877 A2

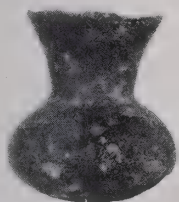

15



16



17



18

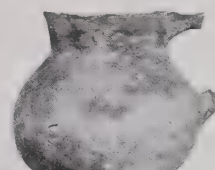

19

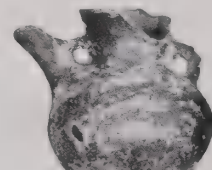

20



21

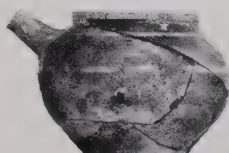

22



23



24

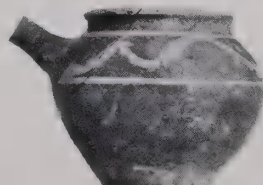

25



26

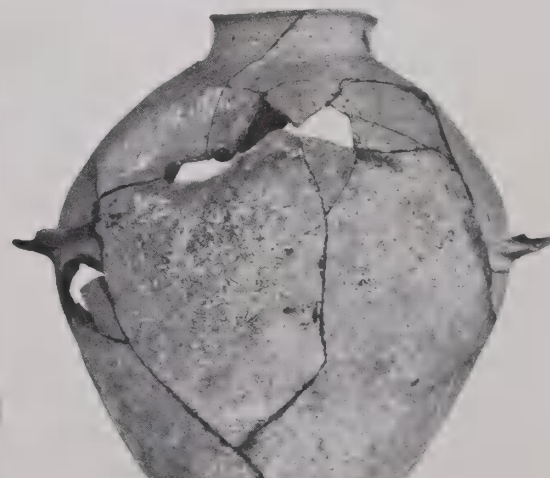

27

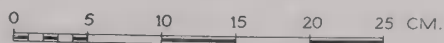

No.	Field No.	Designation	Description
1	P 2938	"Teapot"	See Pl. 11:32
2	P 2988	Cup	See Pl. 11:27
3	P 2989	Cup	See Pl. 11:26



1



2

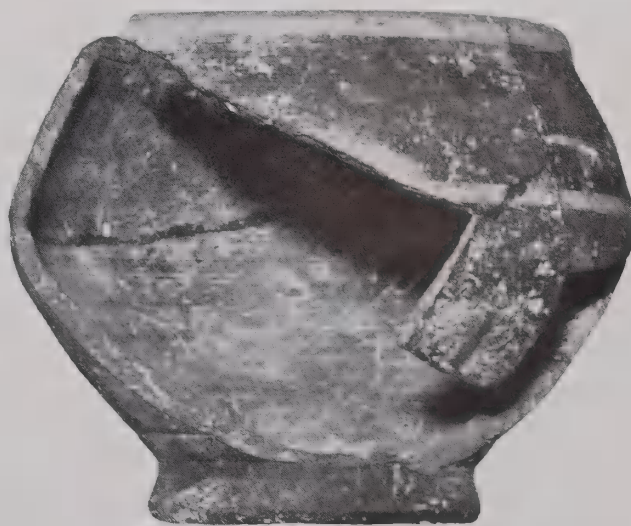

3

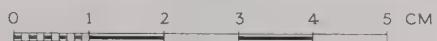

MB I POTTERY FROM TOMB 877 A 2 (SEE PP. 33-36). ACTUAL SIZE

No.	Field No.	Designation	Description	Date
TOMB 877 B 2				
1	P 2961	"Teapot"	See Pl. 12:7	MB I
2	P 2997	Jug	See Pl. 12:8	MB I
TOMB 877 C 2				
3	P 2965	"Teapot"	See Pl. 12:12	MB I
4	P 2967	"Teapot"	See Pl. 12:14	MB I
5	P 2960	"Teapot"	See Pl. 12:13	MB I
6	P 2972	Lamp	See Pl. 12:11	MB I
TOMB 877 A FILL				
7	P 2897	Smelting-brazier?	See Pl. 12:17	LB II
8	M 2588	Ring bezel	Pottery, brown ocher 2, punctured decoration (see p. 173)	LB II?
TOMB 877 A 1				
9	P 2910	Bowl	See Pl. 13:7	LB II
10	P 2906	Bowl	Intact, brown ocher 2 surface, blackened by fire inside	LB II
11	P 2911	Jug	See Pl. 12:21	LB II
12	P 2985	Jar	See Pl. 12:22	LB II
13	P 2904	Jar	See Pl. 12:23	LB II
14	P 2924	Jug	See Pl. 12:19	LB II
15	P 2918	Funnel	See Pl. 13:10	LB II
16	P 2902	Lamp	See Pl. 13:11	LB II
17	P 2984	Lamp	Complete, .051 high, well fired, blue-black 3 core, brown ocher 2 surface, blackened by fire	LB II
18	P 2920	Jar	See Pl. 13:14	LB II
19	P 2925	Jug	See Pl. 12:24	LB II
20	P 2921	Jar	See Pl. 13:12	LB II

TOMB 877 B2

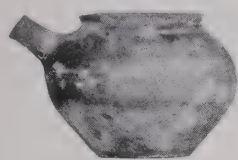

1



2

TOMB 877 C2

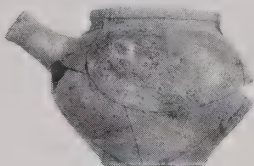

3

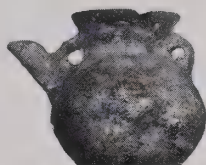

4

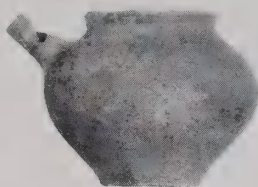

5

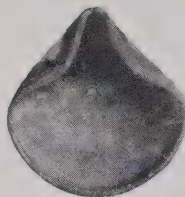

6

TOMB 877 A FILL

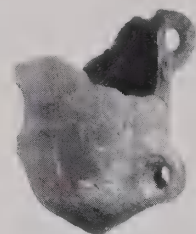

7

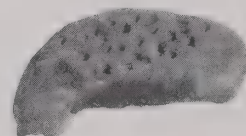

8

TOMB 877 A1



9

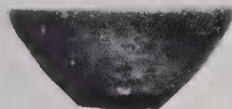

10

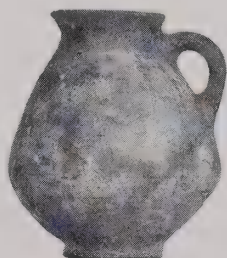

11



12



14

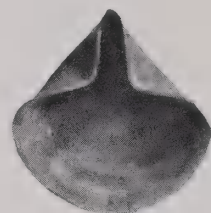

16



13



15

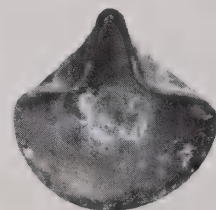

17



18

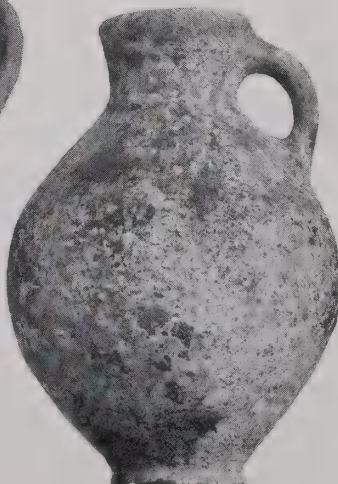

19



20

No.	Field No.	Designation	Description
TOMB 877 A 1			
1	M 2611	Flint	T. .010, polished
2	M 2603	Knife blade	T. .003, "bronze"
3	M 2606	Cylinder seal	Intact, fayence, naples yellow 3 (see pp. 182-84 and cf. Hogarth, <i>Hittite Seals</i> , Fig. 73)
4	M 2610	Spear butt	Intact but oxidized, "bronze," socketed
5	M 2607	Amulet	T. .005, fayence, cerulean blue 3; Egyptian Bes (see p. 178)
6	M 2613	Shell	Intact
7	M 2612	Shell	Intact, t. .012
8	M 2605	Pin	Intact but oxidized, "bronze"
9	M 2604	Pin	Intact, "bronze," one end flattened
		Jars (2)	D. .11, Egyptian "alabaster," vertically pierced lug handles (see p. 186); LB II
TOMB 877 B 1			
10	P 2951	Bowl	See Pl. 13:21
11	P 2957	Bowl	See Pl. 13:22
12	P 2946	Jug	See Pl. 14:3
13	P 2949	Lamp	Intact, .062 high, well fired, brown ocher 3 surface
14	P 2956	Bowl	See Pl. 13:24
15	P 2954	Jug	See Pl. 14:2
16	P 2980	Jug	See Pl. 14:1
17	P 2952	Jar	See Pl. 14:5
18	M 2434	Knife blade	T. .005, "bronze" (Fig. 172:2)

TOMB 877 A1



TOMB 877 B1



LB II OBJECTS FROM TOMB 877 (SEE PP. 33-36). SCALE, POTTERY 1:5; OTHER OBJECTS ACTUAL SIZE

No.	Field No.	Designation	Description
1	M 2461	Amulet	Intact, t. .005, fayence, cerulean blue 3; Egyptian Bes; examined and dated by Petrie to end of 18th or beginning of 19th dynasty (see p. 178)
2	M 2831	Amulet	Intact, t. .005, fayence, cerulean blue 3 to cobalt green 3; Egyptian Bes; examined and dated by Petrie to end of 18th or beginning of 19th dynasty (see p. 178)
3	M 2460	Amulet	Intact, t. .008, fayence, cerulean blue 3 to cobalt green 3; Egyptian Sekhmet(?); examined and dated by Petrie to end of 18th or beginning of 19th dynasty (see p. 178)
4	M 2462	Amulet	Intact, t. .004, fayence, cerulean blue 3; Egyptian sacred eye (see p. 178)
5	M 2827	Beads	Intact, .002 long, fayence, cobalt green 3, oblate
6	M 2451	Bead	Intact, .009 long, fayence, smalt 3, star shape, rayed oblate
7	M 2454	Bead	Fayence, naples yellow 3, irregular long barrel
8	M 2452	Bead	T. .006, glass, ultramarine ash 3 and black lead 3, circular, tabular with convex ends; examined and dated by Petrie to 1300 B.C. $\pm$ 50 years (see p. 179)
9	M 2453	Bead	Same as No. 8
10	M 2441	Bead	Complete, .008 long, glass, smalt 2, circular
11	M 2829	Bead	Intact, carnelian, long pear shape
12	M 2443	Bead	T. .006, carnelian, long barrel lenticular
13	M 2445	Bead	T. .005, carnelian, long barrel lenticular
14	M 2447	Bead	Intact, carnelian, long barrel
15	M 2442	Bead	Same as No. 14
16	M 2423	Bead	Same as No. 14
17	M 2424	Bead	Carnelian, long barrel
18	M 2444	Bead	Same as No. 14
19	M 2446	Bead	Same as No. 14
20	M 2448	Bead	Same as No. 14
21	M 2425	Bead	Same as No. 14
22	M 2449	Bead	Intact, carnelian, short truncated convex bicone
23	M 2426	Bead	Same as No. 22
24	M 2427	Bead	Same as No. 22
25	M 2428	Bead	Same as No. 22
26	M 2450	Bead	Same as No. 22
27	M 2464	Pendant	Intact, carnelian; lotus seed-vessel (see p. 178)
28	M 2458	Scaraboid	Intact, carnelian, roughly cut back (Rowe, <i>Scarabs</i> , No. 798)
29	M 2456	Scaraboid	Intact, .010 wide, carnelian, "bronze" ring (Fig. 176:6), base uninscribed
30	M 2432	Scarab	Intact, steatite, gold setting, traces of "bronze" ring, purely decorative design; Hyksos(?) (Rowe, <i>Scarabs</i> , No. 384)
31	M 2600	Scarab	Steatite, ultramarine ash gray 3 glaze, figure of Amon with blundered inscription before it: beginning may be read ( <i>I</i> ) <i>mn-R</i> <sup>c</sup> ; end, <i>slp-n-R</i> <sup>c</sup> , suggests name of Ramses II; probably 19th dynasty (Rowe, <i>Scarabs</i> , No. 712)
32	M 2617	Scarab	Intact, fayence, prussian green 1 glaze (Rowe, <i>Scarabs</i> , No. 63)
33	M 2421	Cylinder seal	Intact, fayence, cobalt green 3, large birds(?) (ostriches?) (see pp. 182-84)
34	M 2431	Cylinder seal	Intact, serpentine, winged quadruped and 2 spider-like figures above and 2 horned quadrupeds with unidentifiable object below (see pp. 182-84)
35	M 2430	?	Intact, t. .001, gold foil (cf. Petrie, <i>Gaza</i> IV, Pls. XIX-XX 159-61 and p. 9)
36	M 2422	Earring	Intact, electrum (Fig. 178:3)
37	M 2459	Ring	Complete, "bronze" (Fig. 176:5)
38	M 2463	Ring	"Bronze"
39	M 2457	Ring	"Bronze"
40	M 2455	Button?	Glass, ultramarine ash gray 3, india ink 1 spiral decoration; fragment of "bronze" at base may be remains of a loop
41	M 2597	Whorl	Intact, t. .006, ivory (see p. 170)
42	M 2429	Whorl	T. .007, ivory (see p. 170)
43	M 2438	Whorl	Intact, t. .008, bone
44	M 2439	Whorl	Intact, t. .009, bone (Fig. 175:12)
45	M 2440	Whorl	T. .008, bone (Fig. 175:11)
46	M 2436	Whorl	Intact, t. .006, bone (Fig. 175:13)
47	M 2437	Whorl	T. .015, ivory (see p. 170)
48	M 2828	Whorl	T. .010, ivory (see p. 170)
49	M 2435	Spindle	Bone, incised decoration
50	M 2433	Spindle	Complete, bone, incised decoration

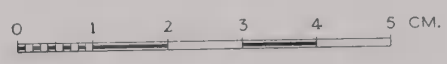

LB II OBJECTS (No. 30 LB II OR HYKSOS) FROM TOMB 877 B 1 (SEE PP. 33-36). ACTUAL SIZE

No.	Field No.	Designation	Description	Date
TOMB 877 B 1				
1	M 2705	Dagger blade	Intact, t. .004, "bronze" (Fig. 171:13)	LB II
2	M 2703	Dagger blade	Intact, t. .007, "bronze" (Fig. 171:11)	LB II
3	M 2704	Dagger blade	T. .006, "bronze" (Fig. 171:12)	LB II
TOMB 877 C 1				
4	P 2971	Bowl	See Pl. 14:11	LB I
5	P 3271	Bowl	See Pl. 14:9	LB I
6	P 2959	Jug	See Pl. 14:15	LB I
7	P 2966	Jug	See Pl. 14:22	LB I
8	P 3007	Jug	See Pl. 14:21	LB II
9	P 2976	Jug	See Pl. 14:13	LB I
10	P 2970	Jug	See Pl. 14:14	LB I
11	P 2969	Jug	See Pl. 14:8	LB I
12	P 2973	Jug	See Pl. 14:17	LB II
13	M 2835	Scarab	Intact, t. .008, steatite, traces of cerulean blue 2 glaze, "bronze" ring, inscribed with pre- nomen of Thutmose III (beetle with wings and wearing sun disk with two uraei); 18th dynasty (cf. Hall, <i>Scarabs</i> , Nos. 768-70)	LB
14	M 2949	Pendant	Intact, t. .004, carnelian; lotus seed-vessel	LB II (cf. Pl. 95:27)
15	M 2950	Bead	Intact, glass, ultramarine ash blue 3, long barrel	LB
16	M 2954	Toggle pin	"Bronze"	LB
17	M 2953	Bead	Glass, davy's gray 3 with chromium oxide 3 patina, long barrel	LB
18	M 2952	Bead	Intact, glass, mottled blue-black 3 and davy's gray 3, short barrel	LB
19	M 2951	Bead	Intact, glass, terre verte 3, irregular circular	LB
20	M 2707	Figurine	Pottery, brown ocher 2, light red 1 decoration; cow's head with horns broken off	LB
21	M 2708	Macehead or loom weight	Intact, t. .021, basalt	LB

TOMB 877 B1



TOMB 877 C1



LB OBJECTS FROM TOMB 877 (SEE PP. 33-36). SCALE, POTTERY VESSELS 1:5; OTHER OBJECTS ACTUAL SIZE

No.	Field No.	Designation	Description	Date
TOMB 989 A 2				
1	P 3304	"Teapot"	See Pl. 15:1	MB I
TOMB 989 C 2				
2	P 3172	"Teapot"	See Pl. 15:6	MB I
3	P 3171	"Teapot"	See Pl. 15:7	MB I
TOMB 989 D 2				
4	P 3220	"Teapot"	See Pl. 15:8	MB I
5	P 3221	"Teapot"	See Pl. 15:9	MB I
TOMB 989 A 1				
6	P 3323	Jug	See Pl. 16:19	LB II
7	P 3206	Jug	See Pl. 16:21	LB II
8	P 3299	Jug	See Pl. 16:22	LB II
9	P 3302	Jug	See Pl. 16:23	LB II
10	P 3169	Jug	See Pl. 16:25	LB II
11	P 3344	Jug	See Pl. 17:2	LB II
12	P 3219	Jug	See Pl. 16:28	LB II
13	P 3161	Jug	See Pl. 16:27	LB II
14	P 3208	Lamp	See Pl. 17:6	LB II
15	P 3202	Jug	See Pl. 17:3	LB II
16	P 3155	Jar	See Pl. 17:12	LB II
17	P 3360	Jar	See Pl. 17:13	LB II
18	P 3160	Jar	See Pl. 17:14	LB II

TOMB 989 A2

TOMB 989 C2

TOMB 989 D2

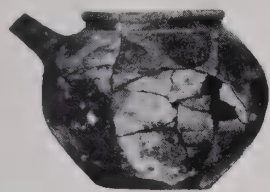

1

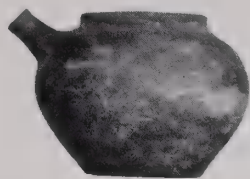

2

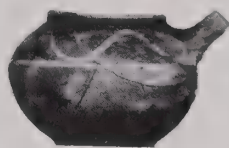

3

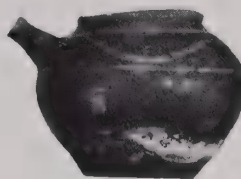

4

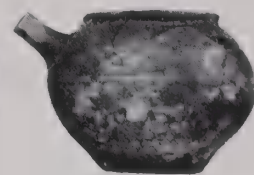

5

TOMB 989 A1



6



7

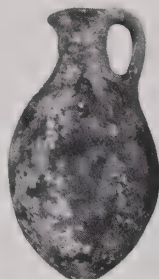

8



9



10



11



12

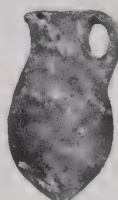

13

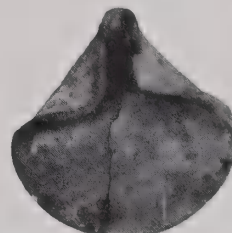

14



15



17



18



16

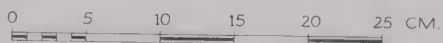

No.	Field No.	Designation	Description	Date
TOMB 989 A 1				
1	P 3296	Chalice	See Pl. 16:10	LB II
2	P 3378	Jug	See Pl. 16:11	LB I
3	P 3150	Jug	See Pl. 16:17	LB II
4	P 3166	Jug	See Pl. 16:13	LB II
5	P 3170	Jug	See Pl. 16:14	LB II
6	P 3388	Jar	Many mixed grits, roman sepia 2 core, brown ocher 2 surface	LB II
7	P 3300	Jar	See Pl. 18:1	LB II
8	M 2891	Bead	Intact, carnelian, short barrel	LB II?
9	M 2896	Flint	Blade, t. .006	LB II?
10	M 2893	Whorl	Intact, t. .004, bone	LB II
	M 2894	Whorl	Same type as No. 10	LB II
11	M 2892	Whorl	Intact, t. .007, bone	LB II
12	M 2895	Whorl	Intact, t. .007, steatite	LB II
TOMB 989 B 1				
13	P 3307	Bowl	See Pl. 19:1	LB I
14	P 3308	Flask	T. .145, many minute light grits, burnt umber 1 core, permanent yellow 3 slip, spaced irregular burnishing	LB II
15	P 3313	Jar	See Pl. 18:4	LB II
16	P 3351	Jug	See Pl. 19:6	LB II
17	P 3306	Jug	See Pl. 19:8	LB II
18	P 3359	Lamp	See Pl. 19:5	LB II

TOMB 989 A1



TOMB 989 B1



No.	Field No.	Designation	Description	Date
TOMB 989 B 1				
1	M 2884	Figurine	T. .022, pottery, blue-black 3 core, brown ocher 2 surface; female	LB
2	M 3189	Figurine	T. .023, pottery, blue-black 3 core, naples yellow 2 surface, modeled back; female. Pl. 89:11 appears to have come from the same mold.	LB
3	M 2882	?	Intact(?), "bronze," tanged	LB
TOMB 989 C 1				
4	P 3176	Bowl	See Pl. 19:11	LB II
5	P 3189	Bowl	See Pl. 19:10	LB II
6	P 3191	Bowl	See Pl. 19:14	LB II
7	P 3177	Bowl	See Pl. 19:9	LB II
8	P 3181	Chalice	Intact, brown ocher 2 surface	LB II
9	P 3186	Chalice	See Pl. 19:17	LB II
10	P 3175	"Cup and saucer"	See Pl. 19:16	LB II
11	P 3310	Milk bowl	See Pl. 19:15	LB II
12	P 3386	Jug	See Pl. 19:23	LB II
13	P 3194	Jug	See Pl. 19:18	LB II
14	P 3002	Jar	See Pl. 20:5	LB II
15	P 3224	Jug	See Pl. 19:24	LB II
16	P 3195	Jug	See Pl. 19:25	LB II
17	P 3180	Jug	See Pl. 19:21	LB II
18	P 3197	Jug	See Pl. 19:22	LB II
19	P 3192	Jug	See Pl. 19:20	LB II
20	P 3183	Jug	See Pl. 20:2	LB II
21	P 3173	Jug	See Pl. 20:1	LB II
22	P 3179	Jug	See Pl. 20:4	LB II
23	P 3196	Lamp	See Pl. 20:7	LB I
24	P 3182	Lamp	See Pl. 20:6	LB II

TOMB 989 BI



1

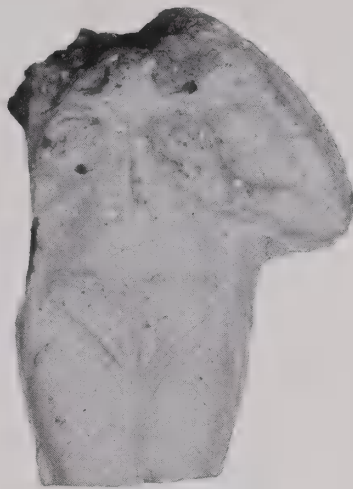

2

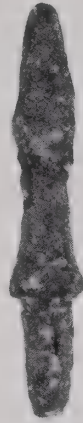

3

TOMB 989 CI

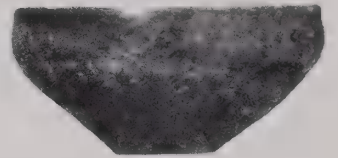

4



5

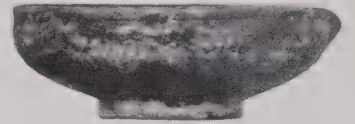

6

TOMB 989 CI

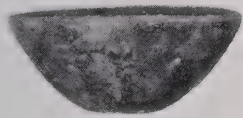

7



8

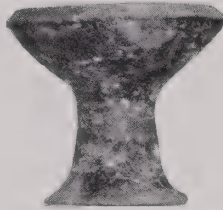

9

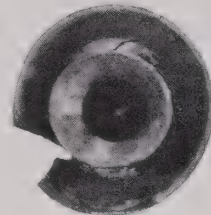

10

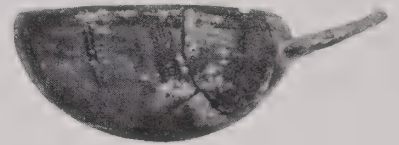

11



12



13



14



15



16



17



18

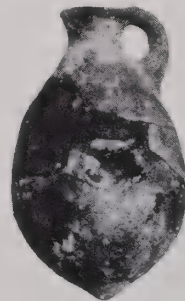

19



20

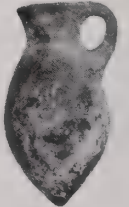

21



22

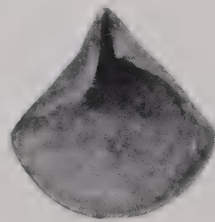

23

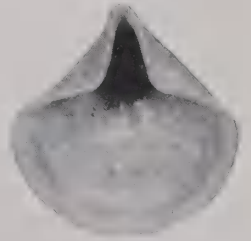

24

LB OBJECTS FROM TOMB 989 (SEE P. 40). SCALE, POTTERY VESSELS 1:5; OTHER OBJECTS ACTUAL SIZE

No.	Field No.	Designation	Description	Date
1	M 2860	Whetstone	T. .026, basalt	LB
2	M 2879	Flint	T. .007, right end trimmed	LB
3	M 2851	Flint	T. .005, single serrations on upper edge, left end trimmed	LB
4	M 2832	Scarab	Intact, carnelian, gold setting, incised lines on base (Rowe, <i>Scarabs</i> , No. 379)	LB
5	M 2858	Scarab	Intact, steatite, traces of naples yellow 1 glaze, inscribed with prenomen of Ramses II ( <i>Wsr-m3-t-R3-štp-n-R3</i> ) (Rowe, <i>Scarabs</i> , No. 679; cf. Newberry, <i>Scarabs</i> , Pl. XXXIV 23)	LB II
6	M 2857	Scarab	Intact, steatite, traces of prussian green 2 glaze, inscribed with uraeus and feather; 19th dynasty (Rowe, <i>Scarabs</i> , No. 740; cf. <i>Beth-Pelet</i> II, Pl. L 78, and Petrie, <i>Hyksos and Israelite Cities</i> , Pl. XXXVII 30-32)	LB II
7	M 2849	Scarab	Intact, t. .006, carnelian, base uninscribed (Rowe, <i>Scarabs</i> , No. 657)	LB
8	M 2614	Scaraboid	Steatite, traces of naples yellow 1 glaze, fish back, inscribed with blundered name of Amon-Re (Rowe, <i>Scarabs</i> , S. 69(A); cf. <i>Beth-Pelet</i> II, Pl. L 77, and Petrie, <i>op. cit.</i> Pl. XXXVII 29)	LB
9	M 2887	Beads	Carnelian, long barrel	LB
10	M 2888	Beads	Same as No. 9	LB
11	M 2616	Bead	Carnelian, standard truncated convex bicone	LB
12	M 2847	Bead	Carnelian, short barrel	LB
13	M 2846	Bead	Intact, fayence, payne's gray 3 glaze, irregular circular fluted	LB
14	M 2890	Bead	Fayence, ultramarine ash blue 3 glaze, irregular circular	LB
15	M 2848	Bead	Intact, t. .017, fayence, circular, short axis perforated	LB
16	M 2843	Beads	Glass, ultramarine ash blue 3, long barrel	LB
17	M 2850	Bead	Intact, t. .007, serpentine, rectangular, scratched decoration	LB
18	M 2840	Pendants	Carnelian; lotus seed-vessels	LB II (cf. Pl. 95:27)
19	M 2878	Ring	"Bronze" (Fig. 176:8)	LB
20	M 2877	Whorl	T. .007, steatite	LB
21	M 2921	Inlay?	Bone, upper end trimmed, incised decoration, back worked to flat surface and marked with small striations possibly for adherence (see p. 186)	LB II
22	M 2881	Whorl	T. .005, bone	LB II (cf. Fig. 175)
23	M 2859	Whorl	Intact, t. .007, bone	LB II (cf. Fig. 175)
24	M 2838	Whorl	T. .012, bone	LB II (cf. Fig. 175)
25	M 2836	Whorl	T. .005, bone	LB II (cf. Fig. 175)
26	M 2852	Spindle?	Bone, possibly part of No. 29 or No. 30	LB
27	M 2837	Whorl	Intact, t. .005, bone	LB II (cf. Fig. 175)
28	M 2834	Whorl	T. .007, bone	LB II (cf. Fig. 175)
29	M 2853	Spindle	Bone, incised decoration (cf. No. 26)	LB II (cf. Fig. 175:6)
30	M 2856	Spindle	Same as No. 29	LB II (cf. Fig. 175:6)



LB OBJECTS FROM TOMB 989 C 1 (SEE P. 40). ACTUAL SIZE

No.	Field No.	Designation	Description
TOMB 989 D 1			
1	M 2898	Borer	Intact, "bronze," top squared to fit into haft
2	M 3129	Flint	Sickle, t. .010, single serrations on left edge, right edge and both ends trimmed
TOMB 878 A			
3	P 3333	Bowl	See Pl. 20:12
4	P 3328	"Teapot"	See Pl. 20:15
5	P 3329	Jug	Many mixed grits, permanent brown 2 core, brown ocher 2 inside surface, indian red 2 wash outside and over rim, handmade
6	P 3350	Jug Flints	See Pl. 20:17 MB I?
TOMB 878 D			
7	M 3180	Beads	Intact, fayence, davy's gray 3, standard cylinder
8	M 3181	Beads Bead	Intact, fayence, cobalt green 3, short barrel Limestone; MB I
TOMB 884 A			
9	M 2552	Pin	Intact, copper (see p. 161 for analysis), end flattened and coiled
10	P 3415	Jar	See Pl. 20:22
11	P 3412	Jug	See Pl. 20:29
12	P 3418	"Teapot"	See Pl. 20:25
13	P 3411	"Teapot"	Many minute mixed grits, naples yellow 1, handmade
TOMB 1098 SHAFT			
14	P 4038	Jug	See Pl. 21:6
15	P 4039	"Teapot"	See Pl. 21:4
TOMB 1098 A			
16	P 4042	Jar	See Pl. 21:8
17	P 4040	Jug	See Pl. 21:7
18	P 4041	Jar	See Pl. 21:11
19	P 4043	Jar	See Pl. 21:10
20	P 4037	Jar	See Pl. 21:9

TOMB 989 D I

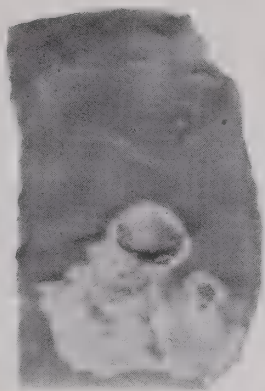

2

TOMB 878 A

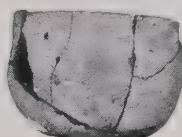

3

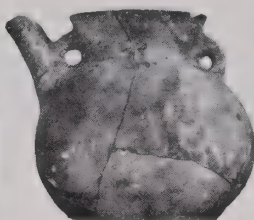

4



5

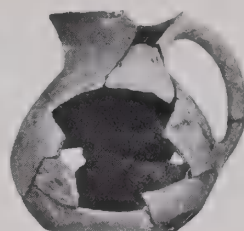

6

TOMB 878 D



7



8

TOMB 884 A



9



10



11



12

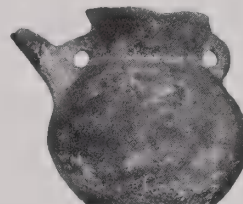

13

TOMB 1098 A

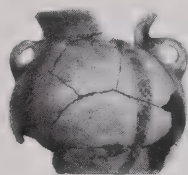

16

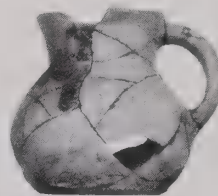

17



18

TOMB 1098 SHAFT

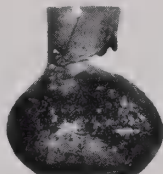

14

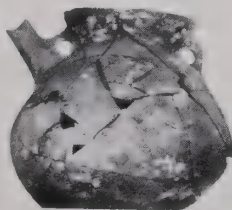

15



19

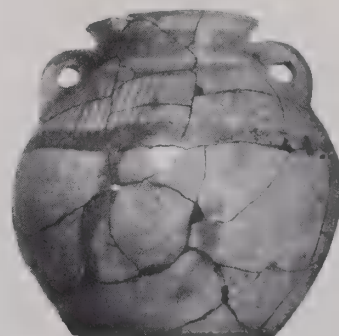

20

No.	Field No.	Designation	Description
			TOMB 891 A
1	P 3614	Jar	See Pl. 21:20
2	P 3601	Jar	See Pl. 21:12
			TOMB 922 A
3	P 3384	Jug	See Pl. 22:1
			TOMB 1014 A
4	P 3608	"Teapot"	See Pl. 22:3
5	P 3607	Jug	See Pl. 22:7
6	P 3606	Jug	See Pl. 22:6
			TOMB 1014 B
7	M 3228	Needle	Complete, bone
8	M 3227	Borer	Intact, copper (see p. 161 for analysis), one end trimmed to fit into haft; found in hole in wall
9	M 3226	Toggle pin	Intact, copper (Fig. 174:2; see p. 161 for metal analysis)
10	M 3225	Toggle pin	Intact, copper (Fig. 174:3; see p. 161 for metal analysis)
			TOMB 1120 A
11	P 3975	Bowl	See Pl. 22:10
12	P 3976	Bowl	See Pl. 22:11
13	P 3967	Jar	See Pl. 22:14
			TOMB 1120 B
14	P 3970	Jar	See Pl. 22:18
15	P 3968	Cup	See Pl. 22:19
	M 3427	Borer	.046 × .005, copper (see p. 161 for analysis), one end squared to fit into haft; MB I
			TOMB 1120 E
16	P 3972	Jug	See Pl. 22:23
17	P 3973	Jug	See Pl. 22:24

TOMB 891 A

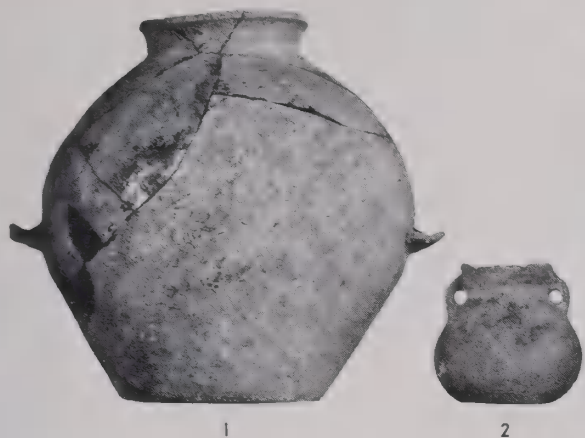

1

2

TOMB 922 A

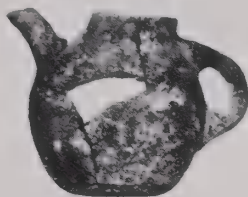

3

TOMB 1014 A

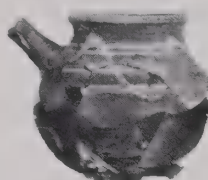

4



5

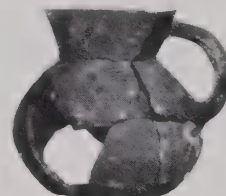

6

TOMB 1014 B

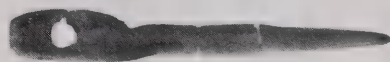

7

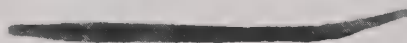

8



9

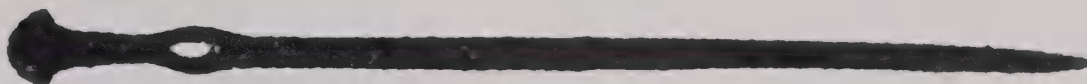

10

TOMB 1120 B



14

TOMB 1120 A

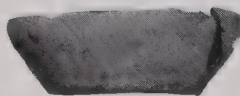

11

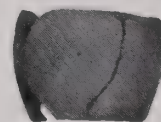

12

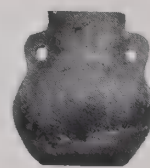

13

TOMB 1120 E



15

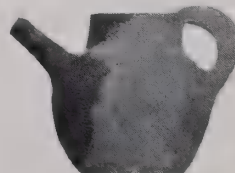

16

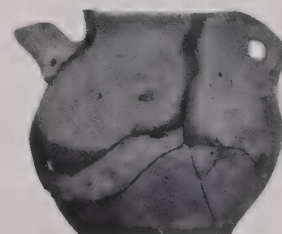

17

No.	Field No.	Designation	Description
1	x 02831	Bowl	See Pl. 23:2
2	02828 <i>a</i>	Bowl	Permanent brown 2
3	7080	Bowl	Charcoal gray 3 core, permanent brown 3 surface
4	7084	Bowl	Brown ocher 3
	7090	Bowl	Same type as No. 4; MB II
5	7072	Bowl	See Pl. 23:11
6	7068	Bowl	Burnt sienna 3
7	x 2913	Jug	See Pl. 23:20
8	2827	Jug	Permanent yellow 3, traces of vertical burnishing, double handle
9	02829	Jug	See Pl. 23:18
10	2831	Jug	Permanent brown 3, naples yellow 3 slip, indian red 2 decoration: horizontal bands on shoulder, vertical bands on body
11	x 2891	Jug	See Pl. 23:15
12	x 2870	Jug	See Pl. 23:17
13	x 2872	Jug	Permanent brown 3, indian red 3 wash, burnished
14	x 2918	Jug	See Pl. 23:27
15	x 2919	Jug	See Pl. 23:30
16	x 2864	Jug	See Pl. 23:19
17	x 2917	Jug	See Pl. 23:22
18	x 511	Toggle pin	"Bronze"
19	x 506	Toggle pin	"Bronze"
	x 509-10	Toggle pins	Same type as No. 19; MB II
20	x 505	Toggle pin	Intact but oxidized, "bronze" (Fig. 174:5)
21	x 507	Toggle pin	Same as No. 20
22	x 504	Toggle pin	Same as No. 20 (Fig. 174:6)



MB II OBJECTS FROM TOMB 24 (SEE PP. 48-50). SCALE, POTTERY 1:5; TOGGLE PINS ACTUAL SIZE



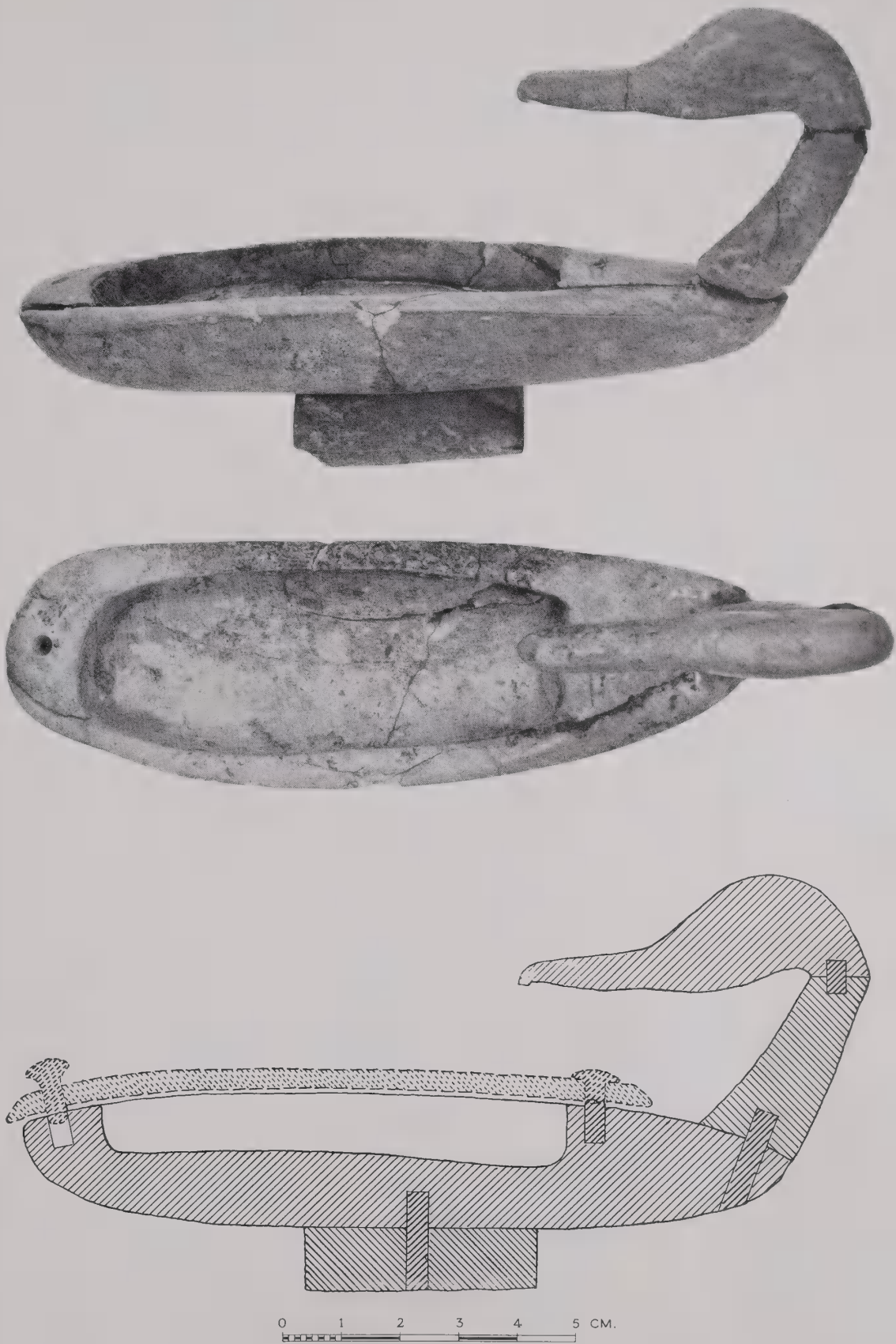

MB II IVORY BOX (No. 503) IN THE FORM OF A DUCK, FROM TOMB 24 (SEE PP. 48-50 AND 188). ACTUAL SIZE

Ivory dowels were used to assemble the parts of the body. The lid is reconstructed in the drawing. It probably pivoted on the pin which is nearer the head. The reconstruction assumes the other pin to have been attached to the lid and used as both a knob and a stop for the lid when closed.

No.	Field No.	Description
1	x 475	"Bronze" ring (see p. 173, n. 206), purely decorative design (Rowe, <i>Scarabs</i> , No. 86)
2	x 476	Scrolls around a name possibly blundered from "Sekhanre" (Rowe, <i>Scarabs</i> , No. 148; cf. H. Gauthier in <i>Bulletin de l'Institut français d'archéologie orientale</i> XV [1918] 90)
3	x 477	Purely decorative design (Rowe, <i>Scarabs</i> , No. 90)
4	x 478	Purely decorative design (Rowe, <i>Scarabs</i> , No. 78)
5	x 479	Purely decorative design (Rowe, <i>Scarabs</i> , No. 85)
6	x 480	Blue glaze, purely decorative design with lilies(?) between scrolls (Rowe, <i>Scarabs</i> , No. 372)
7	x 481	A <i>nfr</i> sign ("beauty" or "goodness") surrounded by scrolls, probably a wish (Rowe, <i>Scarabs</i> , No. 396)
8	x 482	Symbols of union of Upper and Lower Egypt placed base to base (Rowe, <i>Scarabs</i> , No. 197)
9	x 483	Blue glaze, rope and scroll border around hieroglyphs too misshapen or too worn to be legible (Rowe, <i>Scarabs</i> , No. 23)
10	x 484	Scroll border around $\textcircled{\text{𓆎}}$ , probably a wish ( <i>hrw nfr</i> , "holiday"), but taken by Petrie ( <i>Scarabs and Cylinders with Names</i> [London, 1917] Pl. XX S-AC) as the name of a king of about the 14th dynasty (Rowe, <i>Scarabs</i> , No. 124)
11	x 485	Fragment of "bronze" in perforation, inscribed with scrolls around <i>s3.t(?) nfr</i> ("May beauty be thy [fem.] protection"?) (Rowe, <i>Scarabs</i> , No. 123)
12	x 486	Uncertain characters at each side of center design. If inverted, <i>R3</i> (or <i>hrw nfr</i> (or <i>w3d?</i> ) may perhaps be read on one side (Rowe, <i>Scarabs</i> , No. 122)
13	x 487	A <i>k3</i> sign between uraei above, sacred eyes in center, <i>hpr</i> -scarab between "life" signs below. The <i>hpr</i> and <i>k3</i> suggest the name of Sesostri I ( <i>Hpr-k3-R3</i> ) of the 12th dynasty, which was presumably of amuletic value (Rowe, <i>Scarabs</i> , No. 3)
14	x 488	Blue glaze, inscribed with uraeus wearing Lower Egyptian crown, with two <i>s3(?)</i> signs ("magical protection") base to base at each side

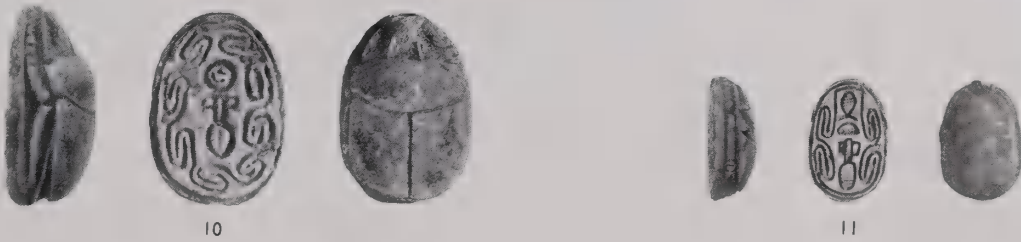
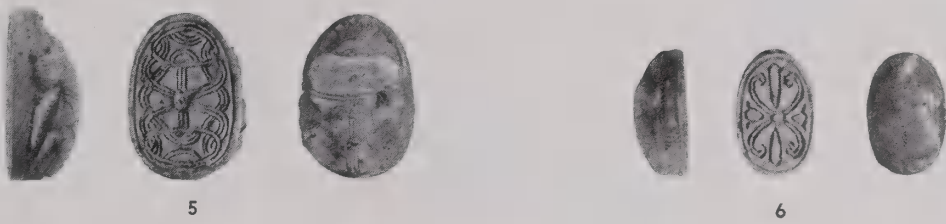
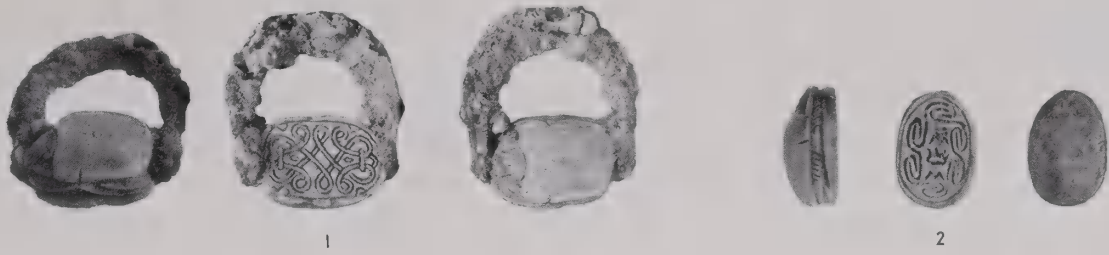

HYKSOS (MB II) SCARABS OF STEATITE FROM TOMB 24 (SEE PP. 48-50). ACTUAL SIZE

No.	Field No.	Description
1	x 489	Winged sun with uraei above falcon wearing Lower Egyptian crown; signs in cartouche behind falcon are presumably not a name but conceivably to be read as a title, $R' n h^3s(t) nb(t)$ , "Sun of every land," or a statement, "To Re belongs every land" (Rowe, <i>Scarabs</i> , No. 223; cf. our p. 185)
2	x 490	Good wishes: $nfr$ ("beauty" or "goodness"), $hpr$ ("existence"), $dd$ ("duration" or "stability") between $sw$ -plants and "life" signs (Rowe, <i>Scarabs</i> , No. 54)
3	x 491	"Life" sign between uraei over "gold" sign with $s^3(?)$ sign ("magical protection") at each side of it (Rowe, <i>Scarabs</i> , No. 45)
4	x 492	Hieroglyphs down sides perhaps name King $H'-k^3-R'$ (Neferhotep II of the 13th dynasty according to Gauthier in <i>Bulletin de l'Institut français d'archéologie orientale</i> XV 79); those down center might then mean " $H'-k^3-R'$ abides," with $nb$ -basket as filler at bottom; decoration at top suggests that at bottom of No. 12 (Rowe, <i>Scarabs</i> , No. 59)
5	x 493	Lower Egyptian crown in basket between falcons over "holiday" (cf. Pl. 105:10) in oval between uraei wearing Lower Egyptian crown, "life" sign at bottom (Rowe, <i>Scarabs</i> , No. 114)
6	x 494	Falcon backed by $hpr$ between $\epsilon$ signs, $nb$ -basket at each end and a "land" (?) sign over lower one; possibly means "(It is) Horus who gives the offering" (Rowe, <i>Scarabs</i> , No. 167)
7	x 495	Lower Egyptian crown at each end; $k^3$ sign between $\epsilon$ signs over "gold" sign in center (cf. for general effect Petrie, <i>Buttons</i> , Pl. X 483) suggests Amenemhet II's name $Nb-k^3w-R'$ (Rowe, <i>Scarabs</i> , No. 9)
8	x 496	Two people kneeling facing each other under a lotus blossom, "gold" sign over $\epsilon^3$ sign (meaning "Great is Hathor"?) between Lower Egyptian crowns below (Rowe, <i>Scarabs</i> , No. 46)
9	x 497	A king wearing Lower Egyptian crown and holding "life" (?) sign in right hand, uncertain signs around him, another Lower Egyptian crown before his legs, $nb$ -basket as filler at bottom (Rowe, <i>Scarabs</i> , No. 94)
10	x 498	"Life" and $dd$ ("duration" or "stability") signs (Rowe, <i>Scarabs</i> , No. 360)
11	x 499	"Bronze" setting (now lost), inscribed with inverted $nb$ -basket over unintelligible signs between uraei(?) (Rowe, <i>Scarabs</i> , No. 118)
12	x 500	Possibly sign for "Lower Egypt" between two $sw$ -plants, $n$ in center; decoration at bottom suggests that at top of No. 4 (Rowe, <i>Scarabs</i> , No. 361)
13	x 501	Lower Egyptian crown in basket and inverted Upper Egyptian crown over plants framing $sm^3$ sign, the whole standing for "union of the Two Lands (Egypt)" (Rowe, <i>Scarabs</i> , No. 129)
14	x 502	"Bronze" ring (see p. 173, n. 206), inscribed with a largely symmetrical design with Lower Egyptian crown at each end under a sacred eye, a bee symbolizing "King of Lower Egypt" over "gold" sign in center, a $sw$ or $sm^3$ sign at each side of latter, and other signs (including two "life" signs at right) over and around bee (Rowe, <i>Scarabs</i> , No. 36)

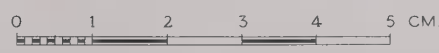
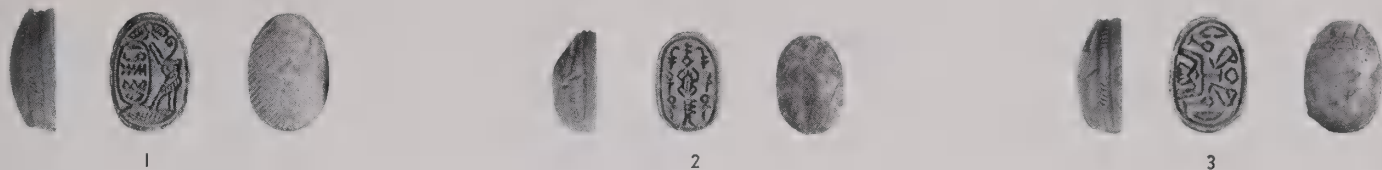

HYKSOS (MB II) SCARABS OF STEATITE (NO. 12 GREEN JASPER) FROM TOMB 24 (SEE PP. 48-50). ACTUAL SIZE

No.	Field No.	Designation	Description	Date
TOMB 24 B				
1	x 772	Figurine	Legs and feet only preserved, t. .021, pottery, traces of indian red 3 wash, incised lines represent toes; female	?
TOMB 42				
2	x 0886	Bowl	Brown ocher 3	LB II
3	x 0887	Bowl	Brown ocher 3, traces of indian red 3 wash	MB II
4	x 886	Bowl	See Pl. 24:2	MB II
5	x 0885	Bowl	Brown ocher 2	LB II
6	x 0887 <i>a</i>	Bowl	Brown ocher 3, traces of indian red 3 wash	MB II
7	x 887	Jug	See Pl. 24:5	MB II
8	x 865	Jug	See Pl. 24:3	MB II
9	x 947	Bowl	Brown ocher 3, traces of indian red 3 wash on inside of rim	MB II
10	x 0887 <i>b</i>	Jug	Permanent brown 3	MB II
11	x 875	Toggle pin	Silver, twisted head (Fig. 174:4)	MB II (see p. 168)
12	x 877	Toggle pin	"Bronze," grooved decoration on head	MB II (see p. 168)
13	x 878	Toggle pin	Same as No. 12	MB II (see p. 168)
14	x 876	Toggle pin	Same as No. 12	MB II (see p. 168)
15	x 863	Arrowhead	T. .005, "bronze," square tang	MB II
16	x 864	Borer	"Bronze," square tang	MB II
17	x 872	Jar	Egyptian "alabaster" (Fig. 184:2)	MB II (see p. 186)
18	x 873	Scaraboid	Steatite, inscribed with two pairs of uraei over <i>nb</i> -basket	MB II
19	x 874	Scarab	.011 wide, pale amethyst, gold setting, silver ring with ornamental wire (Fig. 176:3), base uninscribed	MB II (see p. 173)

TOMB 24 B



1

TOMB 42

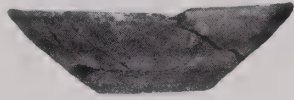

2

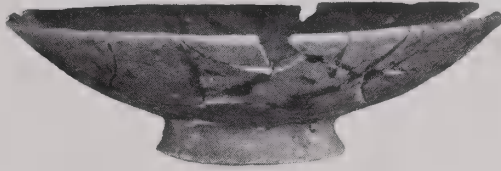

3

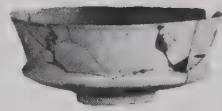

4

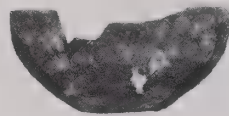

5

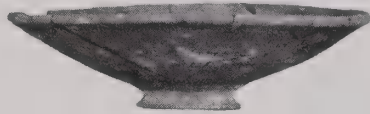

6



7



8



9

TOMB 42

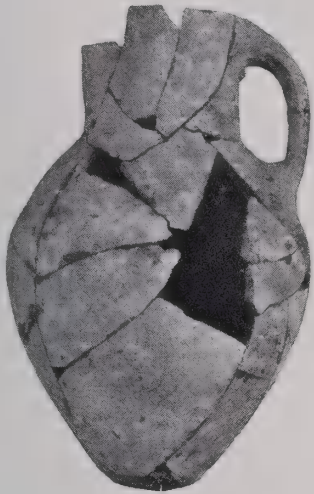

10



11



12



13



14

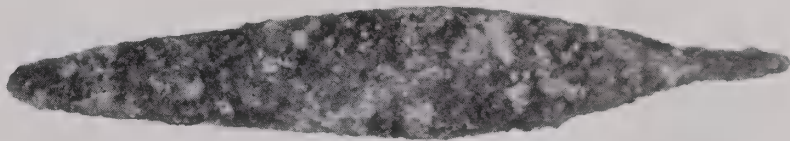

15



16

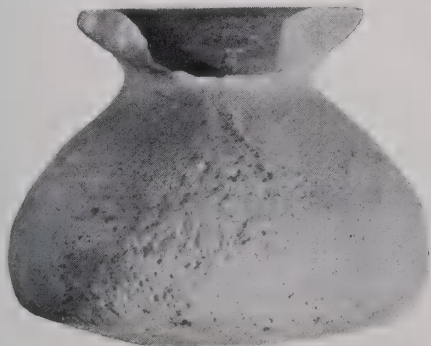

17



18

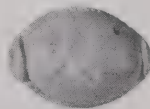

19



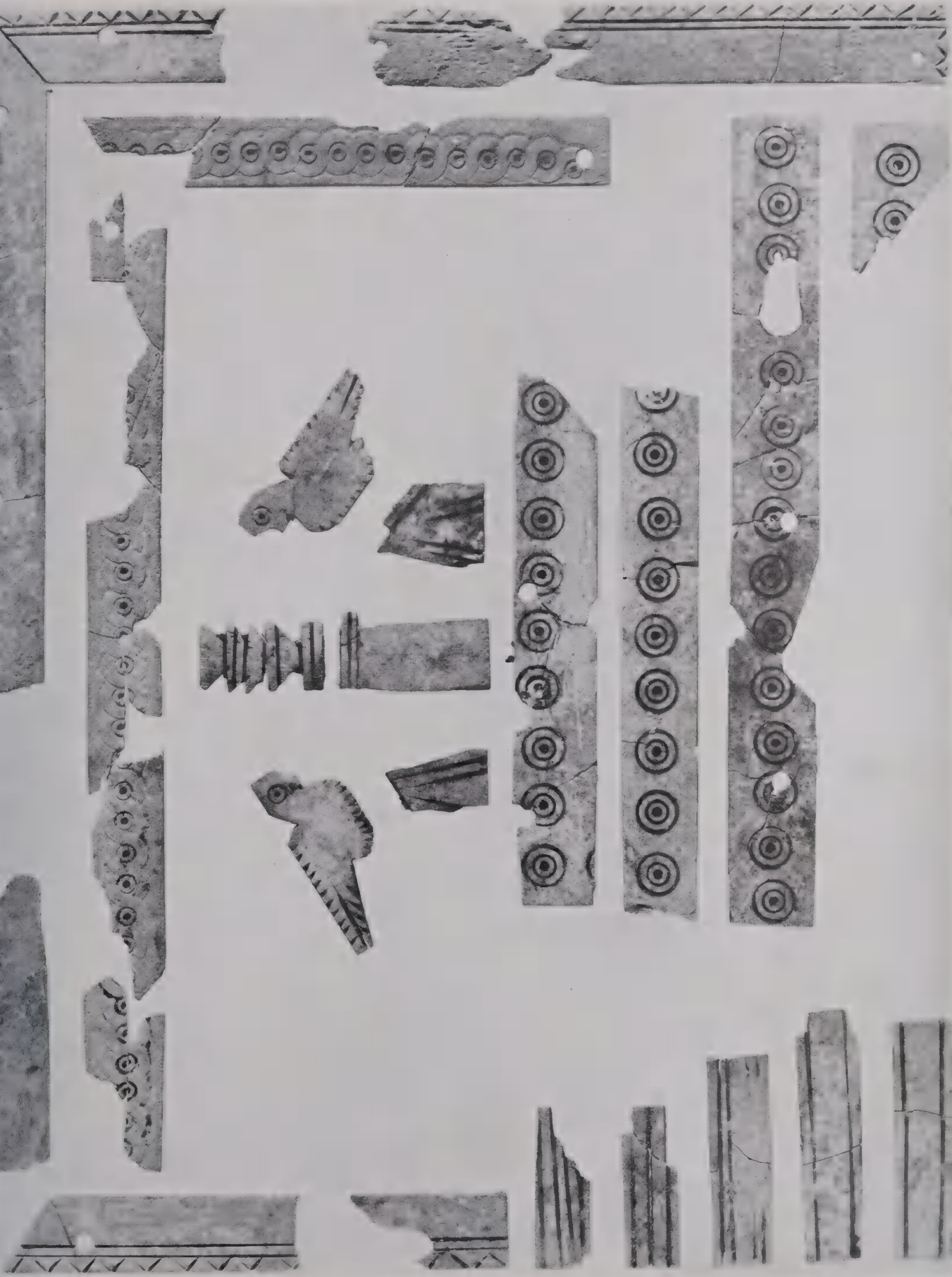

MB II BONE INLAYS (No. x 882) FROM TOMB 42 (SEE P. 51). ACTUAL SIZE

These fragments and those shown on Pl. 109 were all found together. They are probably box inlays and are .001 to .002 thick. The grouping on the plates is purely arbitrary except where there are obvious joins. For possible reconstruction of the beaks of the birds cf. Pl. 111. The long pieces were attached by means of pegs. Though no pegs were found with these fragments, we know this to be true from other deposits (cf. e.g. Pl. 166: 20). Holes for the pegs were cut with a drill. The shorter pieces and the birds may have been fastened by a cementing material. The circles were made with a compass, and much of the straight-line decoration was done with a saw.





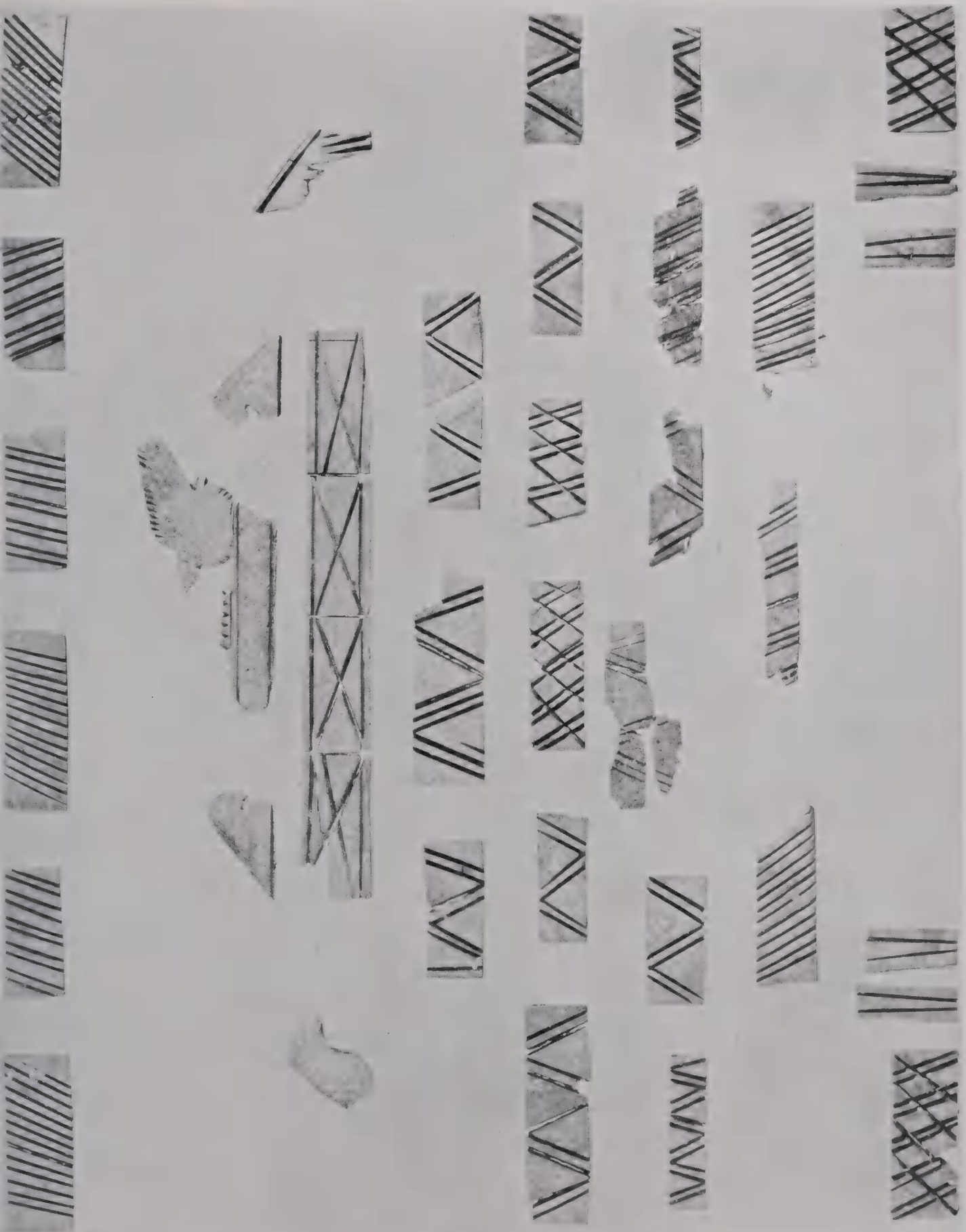

MB II BONE INLAYS (No. x 882) FROM Tomb 42 (SEE P. 51). ACTUAL SIZE  
See Pl. 108 for description.

No.	Field No.	Designation	Description
TOMB 43			
1	x 960	Whorl	Intact, pottery, brown ocher 3 (Fig. 175:2)
2	x 913	Flint	Blade, intact, t. .005
3	x 856	Flint	Intact, t. .007, lower edge serrated and polished
TOMB 44			
4	x 890	Bowl	See Pl. 24:14
5	x 889	Bowl	See Pl. 24:13
6	x 16	Bowl	Brown ocher 3, rim (missing) like that of Pl. 103:6
7	x 13	Jug	Permanent brown 3 core, permanent yellow 1 surface
8	x 14	Jug	See Pl. 24:10
9	x 11	Jug	Well made, brown ocher 3, traces of burnishing
10	x 10	Jug	See Pl. 24:17
11	x 2948	Jug	See Pl. 24:15
12	x 2947	Jug	See Pl. 24:11
13	x 888	Jug	See Pl. 24:16
14	x 6	Jug	See Pl. 24:18
15	x 892	Whorl	Intact, pottery, burnt sienna 3 (Fig. 175:1)
16	x 869	Awl	Bone
17	x 868	Beads	(a) Intact, carnelian, long barrel; (b) fayence, mottled gray, irregular long barrel; (c) intact, fayence, ultramarine ash blue 3, light green core, irregular oblate; (d) intact, glass (see pp. 179 f.), ultramarine ash blue 3, light blue core, irregular oblate; (e) composition, white, long cylinder; (f) intact, fayence, light green, unincised scaraboid
18	x 891	Whorl	Intact, pottery, brown ocher 3 (Fig. 175:3)
19	x 867	Scarab	Steatite, traces of iridescent glaze, purely decorative design

TOMB 43

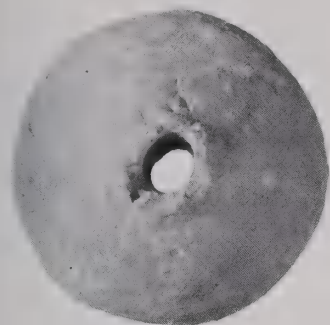

1

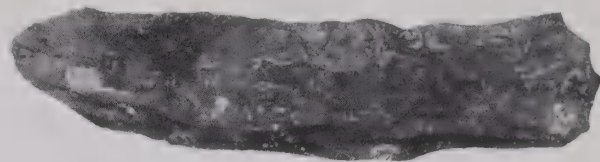
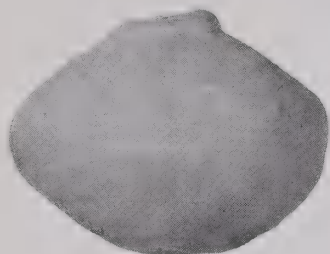

2



3

TOMB 44

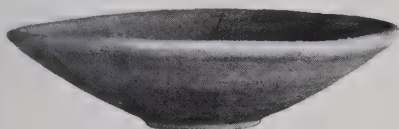

4

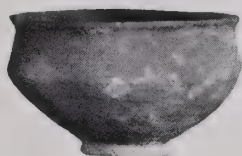

5

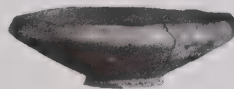

6



7



8



9



10



11



12



13



14

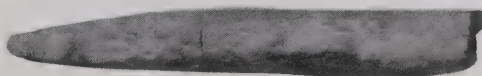

16

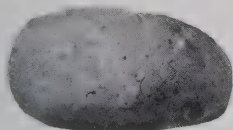

15

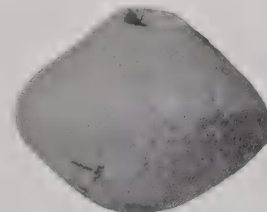

18

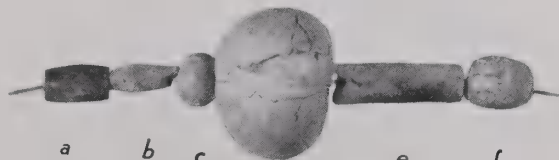

17



19

MB II OBJECTS FROM TOMBS 43-44 (SEE P. 52). SCALE, POTTERY VESSELS 1:5; OTHER OBJECTS ACTUAL SIZE



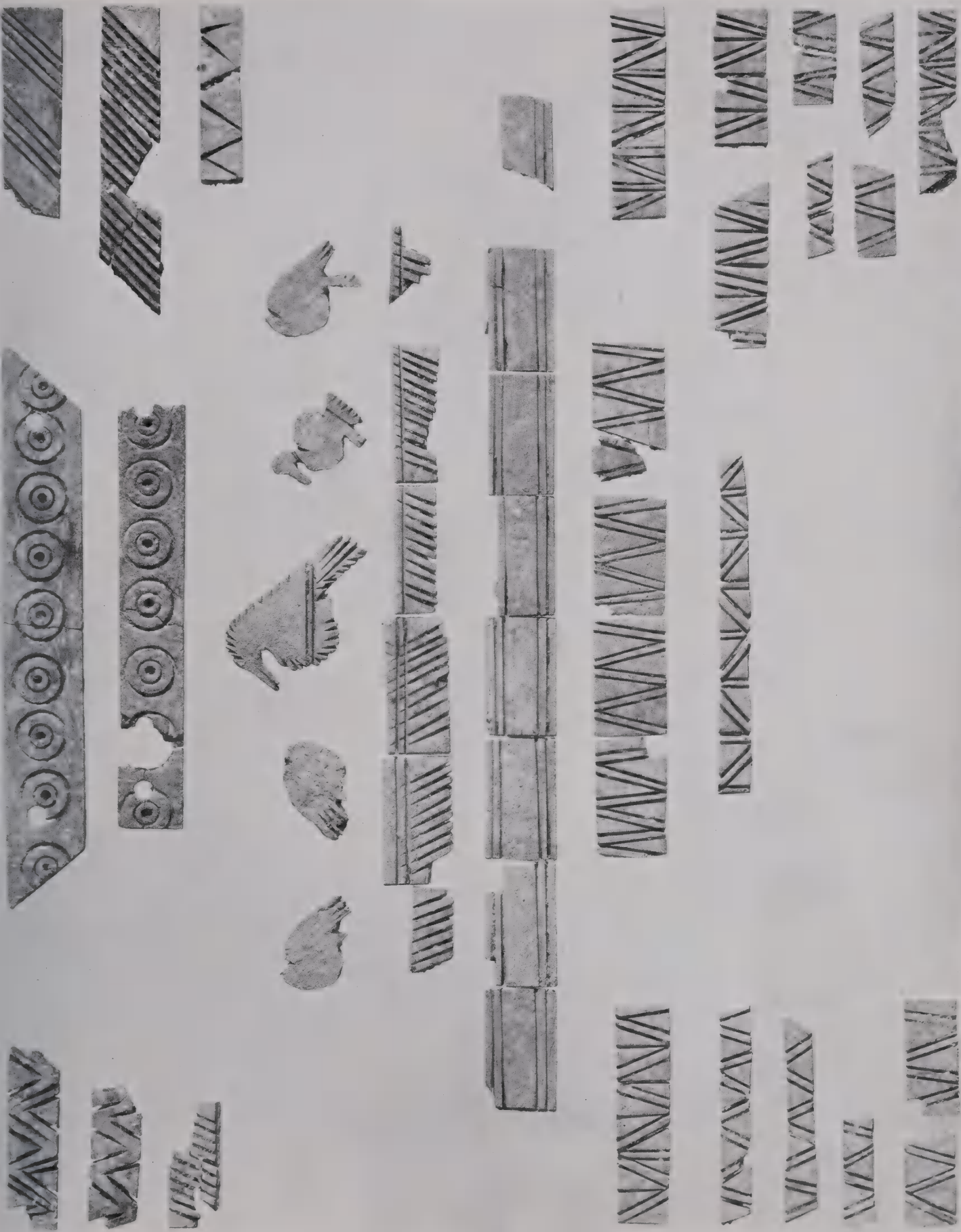

MB II BONE INLAYS (NO. 923) FROM TOMB 45 (SEE P. 52). ACTUAL SIZE  
See Pl. 108 for description.

No.	Field No.	Designation	Description
TOMB 45			
1	7092	Jar	Permanent brown 3
	7093-94	Jars	Same type as No. 1; MB II
2	x 922	Ring	Intact but oxidized, "bronze," overlapped ends (Fig. 176:2)
3	x 936	Flint	Rough serrations on right edge
TOMB 49			
4	x 02958	Bowl	See Pl. 25:7
5	x 2957	Jug	Brown ocher 3, light red 3 slip, burnished, double handle
6	x 2956	Jug	Brown ocher 1, double handle
7	x 2949	Jug	Many mixed grits, brown ocher 3
	x 2951	Jug	Same type as No. 7; MB II
8	x 2953	Jug	See Pl. 25:9
9	x 2961	Jug	Brown ocher 3, traces of naples yellow 3 slip, burnished, double handle
	x 2962	Jug	Same type as No. 9; MB II
10	x 2959	Jug	Permanent brown 3, naples yellow 3 slip, burnished
11	x 1969	Whorl	Pottery, permanent brown 3 (Fig. 175:4)
TOMB 50			
12	1771	Rubber	Intact, t. .076, basalt
13	2010	Pestle	Intact, basalt (see p. 170)
14	2011	Pestle	Intact, basalt (see p. 170)
		Sherds	MB II and LB II
TOMB 51			
15	7096	Jar	Dark grits, brown ocher 3
16	7098	Jug	Permanent brown 3
17	2967	Lamp	Brown ocher 3
	2968	Lamp	Same type as No. 17; MB II
18	x 2971	Jug	Permanent brown 3, burnished, double handle
	01186 a } x 7097 }	Jugs	Same type as No. 18; MB II
19	7095	Jar	Brown ocher 3
	x 11-14	Jugs	Same type as No. 6; MB II

TOMB 45



TOMB 49



TOMB 50



TOMB 51



MB II OBJECTS (Nos. 12-14 MB II or LB II) FROM TOMBS 45 AND 49-51 (SEE PP. 52-55). SCALE, 1:5 EXCEPT NOS. 2-3 AND 11, WHICH ARE ACTUAL SIZE

No.	Field No.	Designation	Description
1	x 02970	Bowl	Permanent yellow 3
2	01186	Bowl	Permanent brown 3, indian red 3 wash
3	2963	Bowl	Permanent brown 3
4	2964	Bowl	Burnt umber 3
5	x 2970	Bowl	Permanent brown 3, indian red 3 wash inside
6	02964	Jug	Burnt umber 3
	x 15	Jug	Same type as No. 6; MB II
7	01186 <i>b</i>	Jug	Permanent brown 3
	x 16	Jug	Same type as No. 7; MB II
8	2966	Bowl	Burnt umber 3
9	2969	Bowl	Large dark grits, brown ocher 3
10	2965	Bowl	Permanent yellow 1; badly warped
11	1182	Scaraboid	Intact, amethyst, base uninscribed
12	x 1236 <i>a</i>	Scaraboid	Intact, amethyst, base uninscribed
13-14	x 1236 <i>b-c</i>	Scaraboids	Amethyst, base uninscribed
15	1185	Toggle pin	"Bronze," grooved decoration on head
16	1184	Bead	Intact, fayence, light green, fluted oblate
17	1183	Scarab	Intact, steatite, purely decorative design
18	x 1237	Inlays	T. .001-.002, bone (cf. Pls. 108-9 and 111)
19	x 1238	Scarab	Steatite, incised with antelope over boar
	7099	Bowl	D. .29, basalt, three legs; same type as Pl. 141:30; MB II

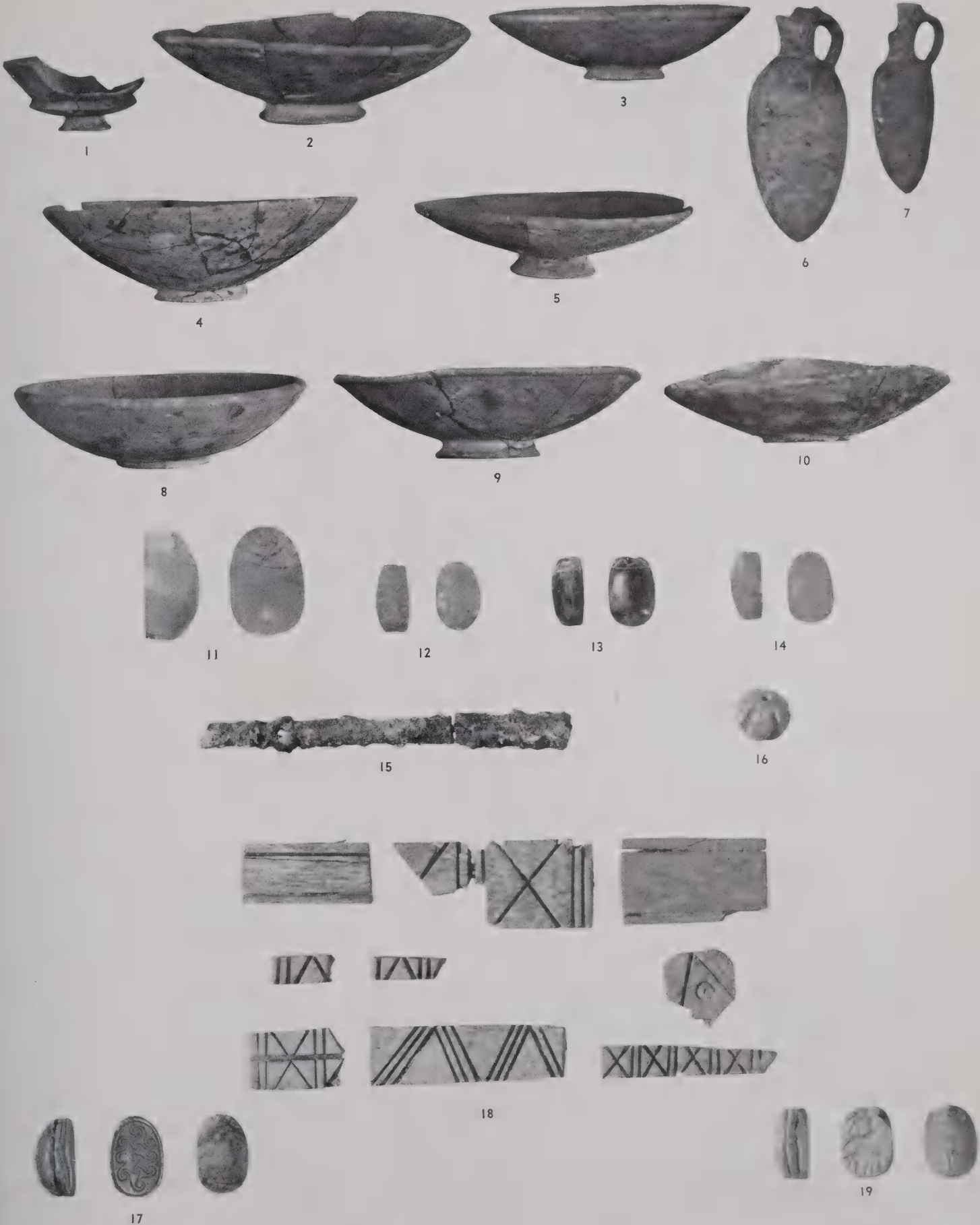

MB II OBJECTS FROM TOMB 51 (SEE P. 55). SCALE, POTTERY 1:5; OTHER OBJECTS ACTUAL SIZE

No.	Field No.	Designation	Description	Date
TOMB 53				
1	1921	Jug	Permanent brown 3, pellet on double handle	MB II
2	01921	Jug	Permanent brown 3	MB II
TOMB 56				
3	1302	Whorl	Bone	LB II? (cf. Fig. 175)
4	1298	Blade	T. .001, "bronze," cutting edge at left (Fig. 173:3)	MB II (see p. 167)
5	1299	Pin	"Bronze"	MB II?
6	1305	Beads	Shell, cylinder disk	MB II?
7	1300	Jar	D. .08, Egyptian "alabaster" (Fig. 184:1)	MB II (see p. 186)
8	1306	Figurine	Foot only preserved, pottery, well fired, permanent brown 3 core, permanent yellow 3 surface, toes painted light red 2; animal; intrusive	MI?
TOMB 233				
9	P 188	Jug	See Pl. 25:15	MB II
10	P 186	Jug	See Pl. 25:16	MB II
11	P 187	Jug	See Pl. 25:17	MB II
12	P 185	Jug	See Pl. 25:19	MB II
TOMB 234				
13	P 365	Bowl	See Pl. 26:5	MB II
14	P 366	Jug	See Pl. 26:6	MB II
15	P 367	Jug	See Pl. 26:7	MB II
16	M 690	Scarab	Steatite, traces of naples yellow 1 glaze, inscribed with sun disk over Lower Egyptian crown in basket between <i>sw</i> -plants over another Lower Egyptian crown	MB II
	M 741	Bowl	Basalt (see Fig. 58)	MB II

TOMB 53

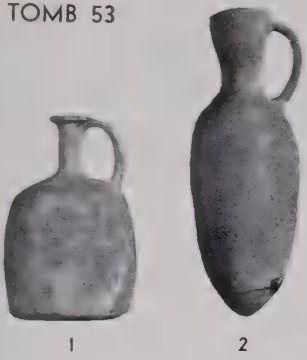

TOMB 56

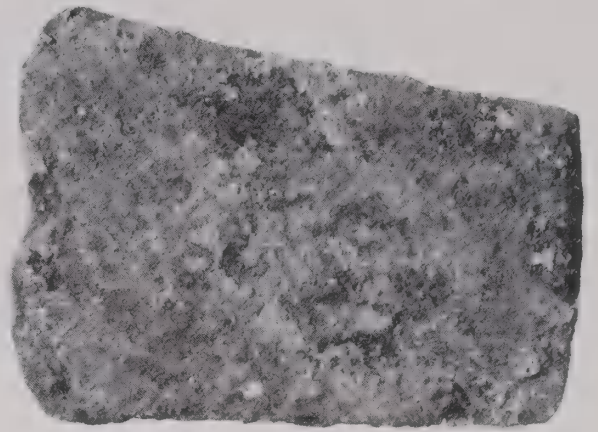
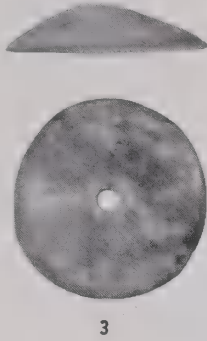

TOMB 56

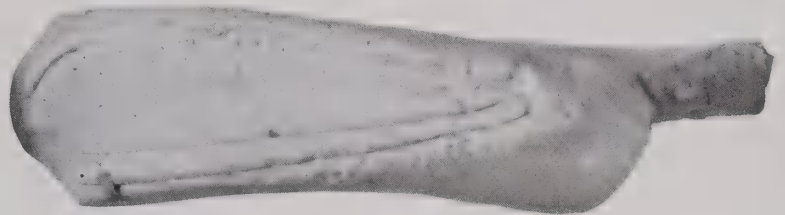
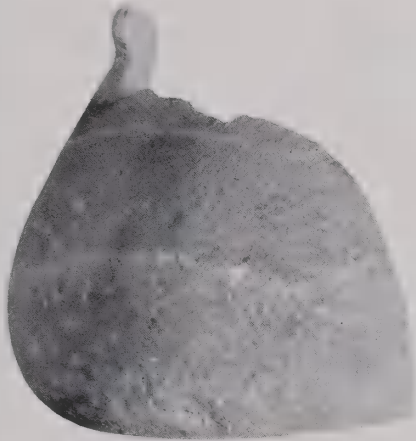
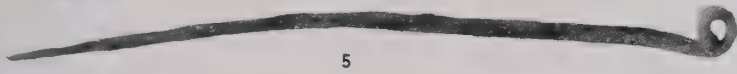

TOMB 233



TOMB 234

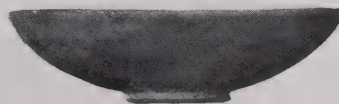

No.	Field No.	Designation	Description
TOMB 251			
1	P 407	Bowl	See Pl. 26:10
2	P 390	Bowl	See Pl. 26:11
3	P 389	Bowl	See Pl. 26:12
4	P 409	Jug	See Pl. 26:13
5	P 410	Jug	See Pl. 26:14
6	P 408	Jug	See Pl. 26:15
7	P 391	Jug	See Pl. 26:17
8	P 406	Jug	See Pl. 26:18
9	P 405	Jug	See Pl. 26:19
10	M 755	Earring	Intact, gold (Fig. 178:1)
11	4353	Astragali	Of some 70 sheep(?) astragali found in this tomb these 2 had been rubbed and polished (see p. 177)
12	4097	Disk	T. .010, pottery, naples yellow 3 surface, traces of light red 3 wash
13	M 754	Flint	T. .011, double serrations and polish on upper edge, lower edge blunted
14	M 749	Pin	Intact, "bronze," square in section
15	4087	Pin	Bone, hollow
TOMB 253			
16	P 393	Jug	See Pl. 27:1
17	P 394	Jug	See Pl. 27:3
TOMB 254			
18	P 404	Jar	See Pl. 27:5
19	M 767	Beads	Fayence, davy's gray 3, (a) long cylinder, (b) oblate, (c) long barrel
20	M 766	Scarab	Steatite, inscribed with a king with staff in one hand and "life" sign in other over <i>nb</i> -basket, <i>nfr</i> ("beauty" or "goodness") in front of him
		Flint	Two fragments; MB II
TOMB 258			
21	P 400	Jug	See Pl. 27:7
22	P 401	Jug	See Pl. 27:8
23	P 402	Jug	See Pl. 27:9
24	4361	Amulet	T. .003, fayence, davy's gray 3, astragalus in form (see p. 177)
25	M 758	Pendant	Complete, t. .002, gold with fayence inlay (see p. 177)

TOMB 251



TOMB 253



TOMB 254

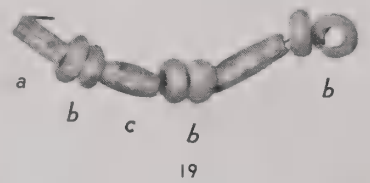

TOMB 258



No.	Field No.	Designation	Description	Scale
TOMB 258				
1	4362	Flint	T. .004	1:1
2	M 759	Flint	T. .008, upper edge serrated and polished, lower edge blunted	1:1
3	4363	Flint	T. .008, upper edge slightly polished	1:1
TOMB 644				
4	P 2389	Bowl	See Pl. 27:17	1:5
5	P 2395	Bowl	See Pl. 27:15	1:5
6	P 2394	Jug	See Pl. 27:12	1:5
7	P 2399	Jug	See Pl. 27:10	1:5
8	M 2127	Scarab	Steatite, traces of yellow glaze, inscribed with <i>hpr-h<sup>c</sup></i> (part of prenomen of Sesostri II) and various good wishes (Rowe, <i>Scarabs</i> , No. 12; cf. Hall, <i>Scarabs</i> , No. 112)	1:1
TOMB 645				
9	P 2479	Jug	See Pl. 27:19	1:5
10	P 2478	Jug	See Pl. 27:18	1:5
11	M 2226	Hammer	Intact, chert	2:5
12	M 2225	Hammer	Intact, limestone	2:5
13	M 2227	Flint	T. .008, one edge polished	1:1
TOMB 911 A 2				
14	P 3109	"Teapot"	See Pl. 31:2	1:5
15	P 3110	"Teapot"	See Pl. 31:3	1:5
16	P 3114	Jug	See Pl. 31:1	1:5
TOMB 911 A 1				
17	P 3078	Bowl	See Pl. 28:1	1:5
18	P 3145	Bowl	See Pl. 28:16	1:5
19	P 3087	Bowl	See Pl. 28:8	1:5
20	P 3090	Bowl	See Pl. 28:6	1:5
21	P 3100	Bowl	See Pl. 28:17	1:5
22	P 3103	Bowl	See Pl. 28:13	1:5
23	P 3097	Bowl	See Pl. 28:22	1:5
24	P 3064	Bowl	See Pl. 28:25	1:5
25	P 3062	Bowl	See Pl. 28:28	1:5
26	P 3093	Bowl	See Pl. 28:31	1:5
27	P 3146	Bowl	See Pl. 28:33	1:5
28	P 3147	Bowl	See Pl. 28:35	1:5
29	P 3240	Jug	See Pl. 28:41	1:5

TOMB 258

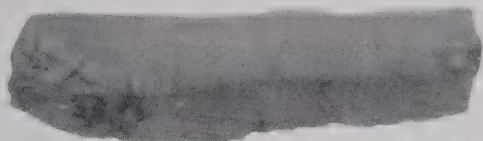

1

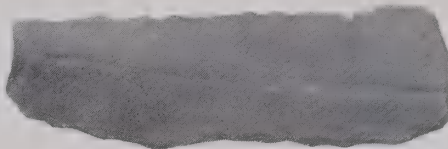

2



3

TOMB 644



4



6

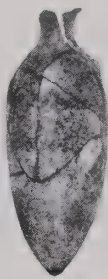

7



5



8



TOMB 645

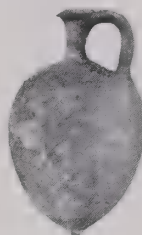

9



10

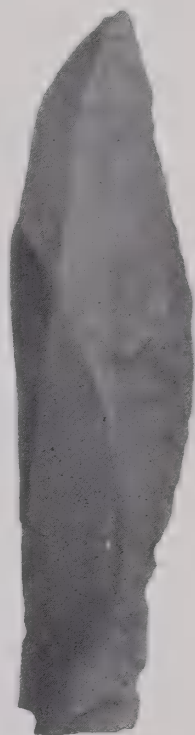

13

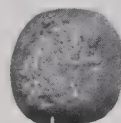

11

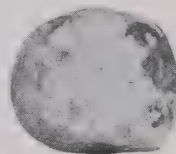

12

TOMB 911 A2

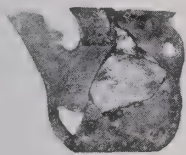

14

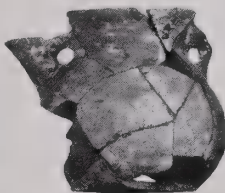

15



16

TOMB 911 A1

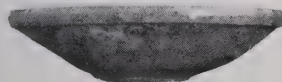

17

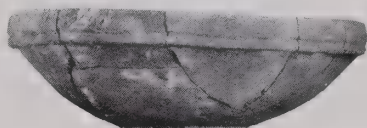

18

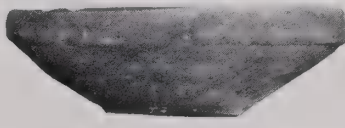

19



20



21

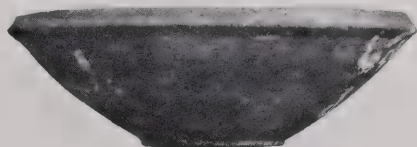

22

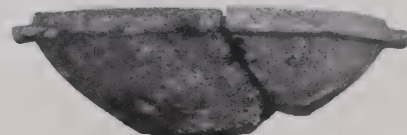

23



24

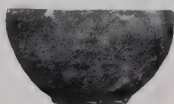

25

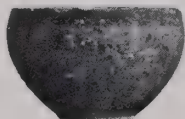

26

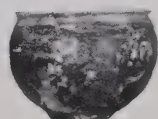

27

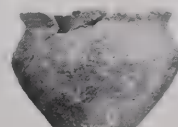

28



29

No.	Field No.	Designation	Description	Date
1	P 3083	Jug	See Pl. 28:45	MB II
2	P 3061	Jug	See Pl. 28:44	MB II
3	P 3058	Jug	See Pl. 29:7	MB II
4	P 3060	Jug	See Pl. 28:47	MB II
5	P 3057	Jug	See Pl. 28:46	MB II
6	P 3105	Jug	See Pl. 29:5	MB II
7	P 3101	Jar	See Pl. 29:9	MB II
8	P 3059	Jar	Many mixed grits, well made, brown ocher 2	MB II
9	P 3396	Jar	See Pl. 29:12	MB II
10	P 3052	Bowl	See Pl. 30:1	LB II
11	P 3076	Bowl	See Pl. 30:2	LB II
12	P 3056	Milk bowl	See Pl. 30:3	LB II
13	P 3053	Chalice	See Pl. 30:4	LB II
14	P 3066	Jug	See Pl. 30:6	LB II
15	P 3092	Jug	See Pl. 30:7	LB II
16	P 3070	Flask	See Pl. 30:5	LB II
17	P 3077	Jug	See Pl. 30:10	LB II
18	P 3051	Jug	See Pl. 30:11	LB II



0 5 10 15 20 25 CM.

MB II AND LB II POTTERY FROM TOMB 911 A 1 (SEE PP. 64-67). SCALE, 1:5

No.	Field No.	Designation	Description
1	M 2763	Dagger blade	T. .006 × .185 × .034, "bronze," 3 rivets for attachment to haft; intentionally bent or "killed"
2	M 2759	Dagger pommel	Intact, t. .027, marble, perforated for attachment to haft, socket bored with tubular drill (Fig. 171:4; cf. AAA XIX, Pl. XXXVII 2)
3	M 2693	Axhead	T. .016 at socket, "bronze" (see p. 167)
4	M 2774	Toggle pin	Intact, "bronze"
5	M 2694	Dagger blade	Intact, t. .009, "bronze," 3 rivets for attachment to haft, ribbed
6	M 2761	Spearhead	"Bronze," traces of wood haft in socket
7	M 2762	Spearhead	Same as No. 6
8	M 2772	Spearhead	"Bronze," socketed
9	M 2773	Dagger blade	Intact, t. .003, "bronze," 3 rivets for attachment to haft



MB II OBJECTS FROM TOMB 911 A 1 (SEE PP. 64-67). ACTUAL SIZE

No.	Field No.	Designation	Description	Scale	Date
TOMB 911 A 1					
1	M 2702	Offering-stand	Intact, "bronze" (Fig. 186:4); once supported a pottery bowl (Pl. 30:1) found close by (see p. 65)	2:5	LB II
	M 2790	Drill-socket	Limestone; same type as Pl. 141:29		MB II or LB II
	M 2861 M 3172 }	Grinders	Basalt; same type as Pl. 173:21 (see Fig. 74)		MB II or LB II
	M 2862	Bowl	Egyptian "alabaster"		MB II or LB II
	M 3171	Hammer-rubber	Basalt		MB II or LB II
TOMB 911 B					
2	P 3084	Bowl	See Pl. 31:4	1:5	LB II
3	M 2699	Vase	"Bronze" (Fig. 186:3)	2:5	LB II
4	M 2697	Bowl	Intact, "bronze" (Fig. 186:6)	2:5	LB II
5	M 2698	Bowl	Intact, "bronze"	2:5	LB II
6	M 2807	Whorl	Intact, t. .005, bone (Fig. 175:15)	1:1	LB II
7	M 2806	Whorl	Intact, t. .006, bone (Fig. 175:17)	1:1	LB II
8	M 2811	Bead	Fayence, near prussian green 3, short barrel with concave ends	1:1	LB II?
9	M 2812	Bead	Intact, fayence, ultramarine ash blue 1, short barrel with concave ends	1:1	LB II?
10	M 2804	Earring	Intact, gold	1:1	LB II (cf. Fig. 178:3)
11	M 2760	Scarab	Intact, t. .009, fayence, cobalt green 1, inscribed with tree flanked by uraei (Rowe, <i>Scarabs</i> , No. 745; cf. Bliss and Macalister, <i>Excavations in Palestine</i> , Pl. 83, No. 12 S, and p. 152)	1:1	LB II?
12	M 2805	Whorl	T. .010, bone (Fig. 175:18)	1:1	LB II
13	M 2809	Whorl	Intact, t. .004, bone	1:1	LB II
14	M 2808	Whorl	Complete, t. .005, bone (Fig. 175:16)	1:1	LB II
15	M 2803	Plaque	T. .001, silver, hole and small rivet at left	1:1	LB II?
16	M 2810	Whorl	Intact, t. .010, steatite	1:1	LB II?
17	M 2700	Knife blade	Complete, t. .005, "bronze," single-edged, end blunt and curved backward (Fig. 172:3)	2:5	LB II (cf. Fig. 171:11-13)
18	M 2701	Knife blade	Intact, t. .005, "bronze," central rib, double-edged (Fig. 172:1)	2:5	LB II (cf. Fig. 171:11-13)

TOMB 911 A1



1

TOMB 911 B



2

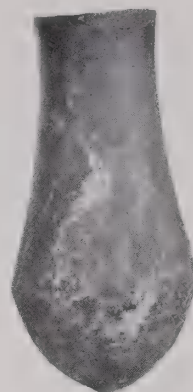

3

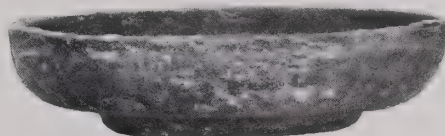

4



5

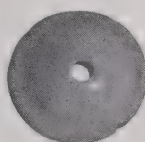

6

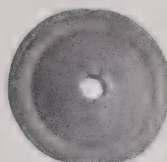

7

TOMB 911 B



8



9



10

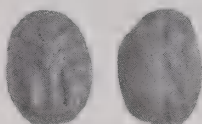

11

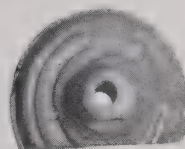

12

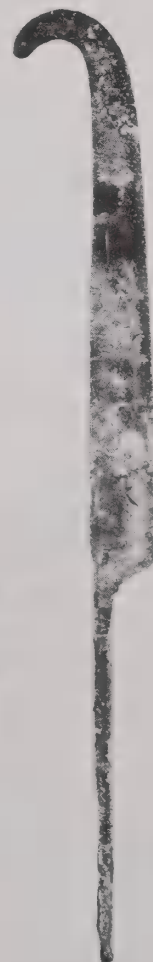

17

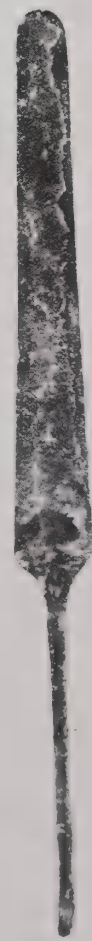

18

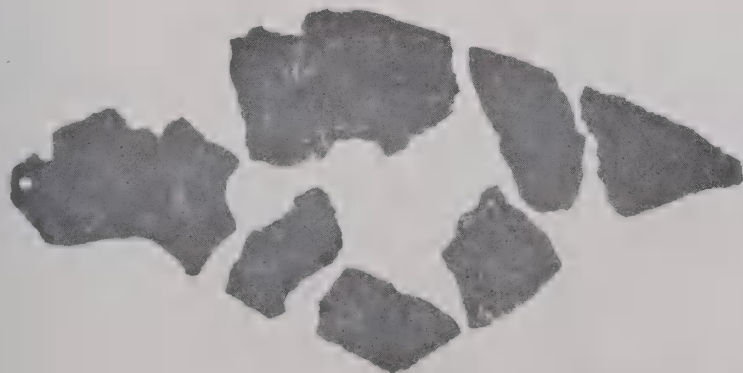

15

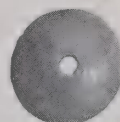

13

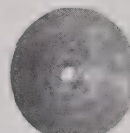

14

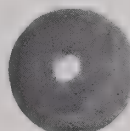

16

No.	Field No.	Designation	Description	Scale	Date
1	P 3247	Bowl	See Pl. 31:5	1:5	LB II
2	P 3232	Bowl	See Pl. 31:6	1:5	MB II
3	P 3116	Chalice	See Pl. 31:7	1:5	LB II
4	M 2775	Bowl	Intact, "bronze"	2:5	LB II (cf. Fig. 186:6)
5	M 2782	Plaque	T. .001, silver	1:1	MB II or LB II
6	M 2781	?	Intact, t. .0001, gold foil, perforated, incised decoration (cf. <i>Beth-Pelet</i> II, Pls. LI and LIII 181 [19th-20th dynasty])	1:1	MB II or LB II
7	M 2779	Pin	"Bronze"	1:1	MB II or LB II
8	M 2780	Pin	"Bronze"	1:1	MB II or LB II
9	M 2787	Flint	Flake, t. .007, worn serrations and polish on upper edge	1:1	MB II or LB II
10	M 2777	Ring	Intact, .006 wide, "bronze" band with electrum knot (see p. 173)	1:1	MB II or LB II
11	M 2778	Ring	.007 wide, "bronze" band	1:1	MB II or LB II
12	M 2695	Arrowhead	Intact, t. .006, "bronze," central rib	2:5	MB II or LB II
13	M 2696	Spearhead	Copper (see p. 161 for analysis), socketed, central rib (see p. 164); found in hole in wall	2:5	MB II (cf. Fig. 170:3-4)
14	M 2776	Knife blade	Intact, t. .007, bronze (see p. 161 for analysis), low central rib on one side	2:5	LB II (cf. Fig. 171:11-13)
15	M 2784	Flints	Sickle, t. .007, .006, .006, .005, .004 respectively, single serrations and polish on lower edge, both ends of each flint trimmed to permit close fitting to form curved blade, upper edges of Nos. 16 and 19 blunted (cf. Petrie, <i>Gerar</i> , Pl. XVI)	1:1	MB II or LB II
16	M 2788				
17	M 2785				
18	M 2783				
19	M 2786				

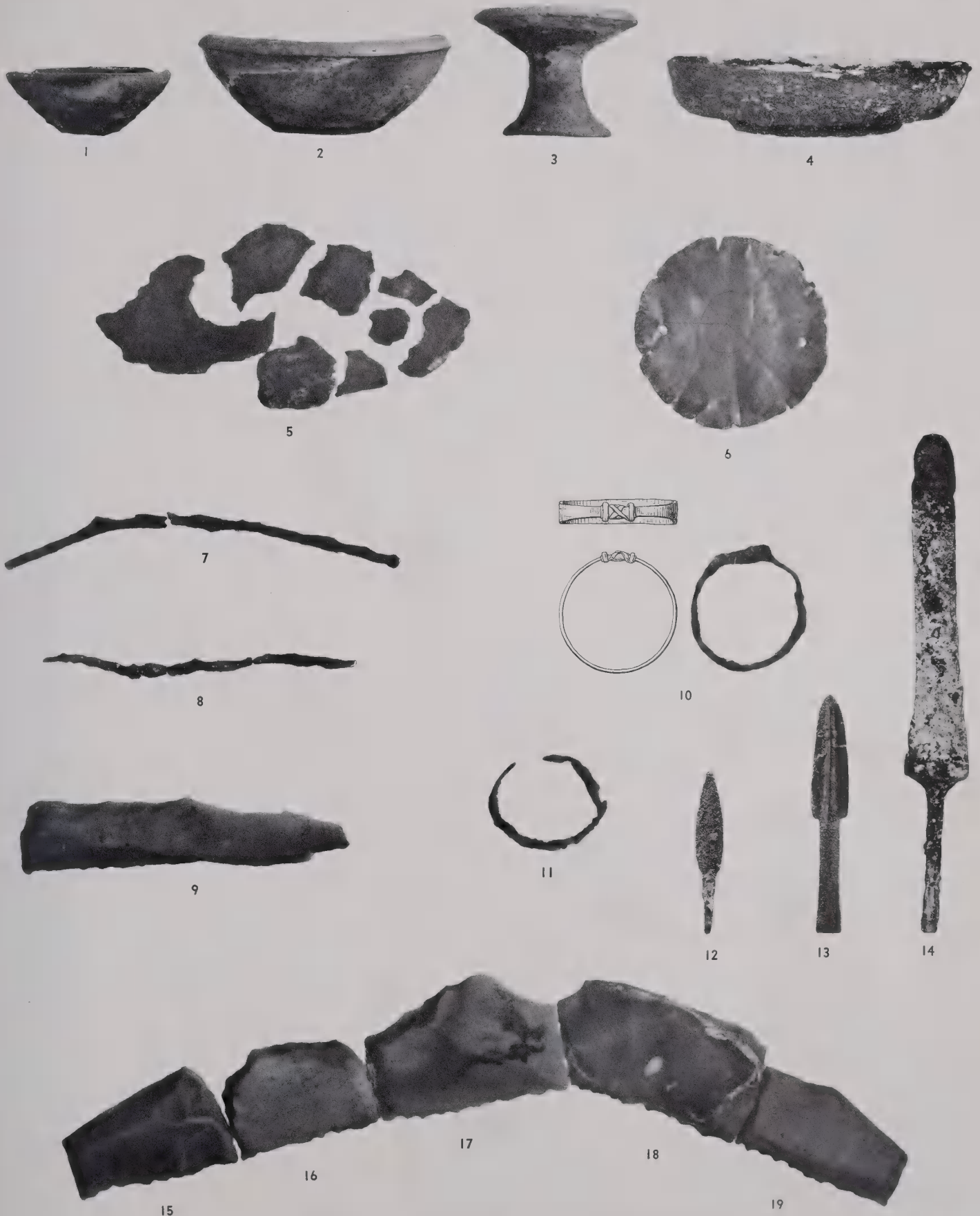

MB II AND LB II OBJECTS FROM TOMB 911 C (SEE P. 67)

No.	Field No.	Designation	Description	Scale
1	P 3128	Bowl	See Pl. 31:13	1:5
2	P 3126	Bowl	Many mixed grits, brown ocher 2, light red 1 wash over rim	1:5
3	P 3119	Bowl	See Pl. 31:8	1:5
4	P 3135	Bowl	See Pl. 31:11	1:5
5	P 3125	Jug	See Pl. 31:19	1:5
6	P 3123	Jug	See Pl. 32:2	1:5
7	P 3121	Jug	See Pl. 32:1	1:5
8	P 3133	Lamp	See Pl. 32:3	1:5
9	P 3238	Jug	See Pl. 31:17	1:5
10	M 2955	Bead	Intact, fayence, cerulean blue 3, oblate	1:1
11	M 3160	Bead	Fayence, ultramarine ash blue 3, oblate disk	1:1
12	M 3159	Pendant	Intact, fayence, near davy's gray 3 (see p. 177)	1:1
13	M 3168	?	Bone, grooved	1:1
14	M 2821	Flint	Arrowhead, intact(?), t. .007, short tang, worn double serrations and polish on both edges	1:1
15	M 2824	Flint	Flake, t. .002	1:1
16	M 2822	Flint	Flake, t. .008	1:1
17	M 3169	Flint	Flake, t. .008	1:1
18	M 3174	Socket	D. .360 and .315, basalt, for door(?) or tournette(?)	1:5
19	M 2820	Flint	Flake, t. .011	1:1
20	M 2825	Flint	Sickle, t. .011, single serrations and polish on upper edge, lower edge and upper right-hand corner blunted	1:1

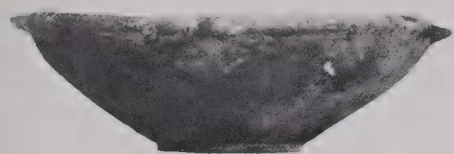

1

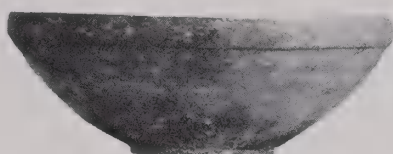

2

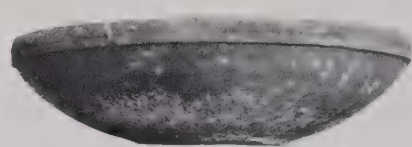

3

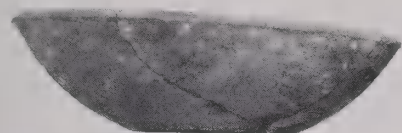

4



5



6

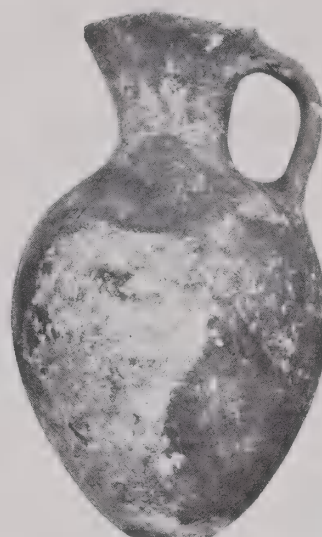

7

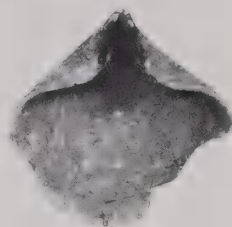

8



9



10



11



12

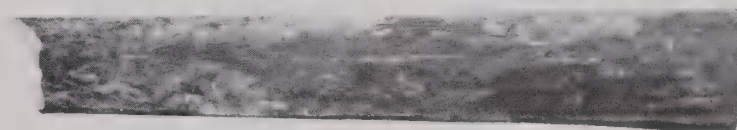

13

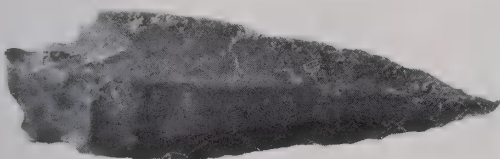

14

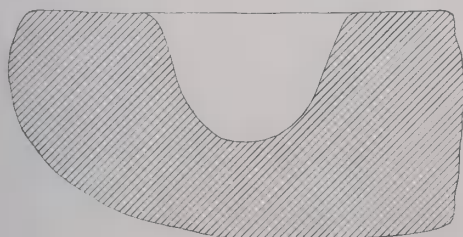

18



15

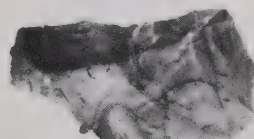

16

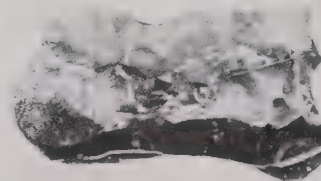

17

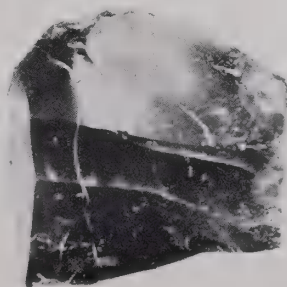

19

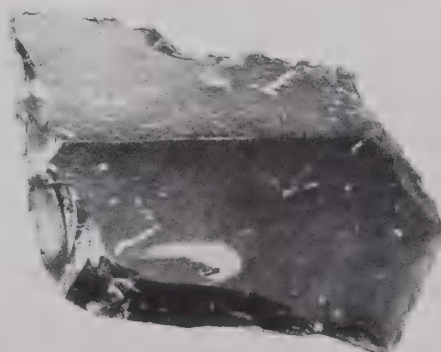

20

No.	Field No.	Designation	Description
1	M 2818	Axhead	Intact, t. .015 at socket, bronze (see p. 161 for analysis); socketed end intentionally mutilated or "killed"; found in hole in wall (Fig. 173:1)
2	M 2816	Axhead	Intact, t. .018 at socket; same as No. 1 (Fig. 173:2)
3	M 2823	Dagger pommel	Marble, socketed, 2 holes for attachment to handle (Fig. 171:3)
4	M 2956	Ring	D. .02, "bronze" (see p. 173)
5	M 2819	Spearhead	"Bronze," socketed, traces of binding-cord on lower end (Fig. 170:4)
6	M 2815	Spearhead	Bronze (see p. 161 for analysis), traces of carbonized haft in socket, remains of bronze clasp around lower end; found in hole in floor
7	M 2813	Spearhead	Bronze (see p. 161 for analysis), socketed (Fig. 170:3)
8	M 2817	Dagger blade	T. .004, copper (see p. 161 for analysis), 2 (originally 3?) rivets for attachment to haft (Fig. 171:5)
9	M 2814	Dagger blade	Intact, t. .007, bronze (see p. 161 for analysis), 3 rivets for attachment to haft, ribbed; found in hole in floor (Fig. 171:6)

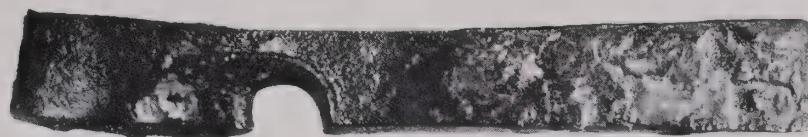

1

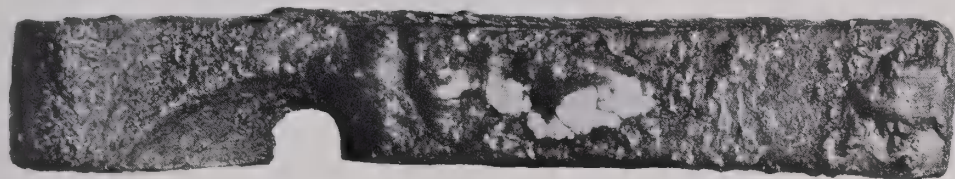

2

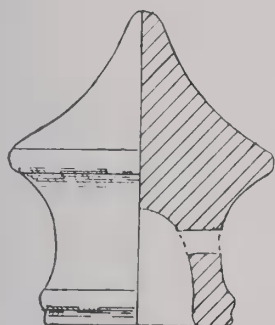

3



4



5

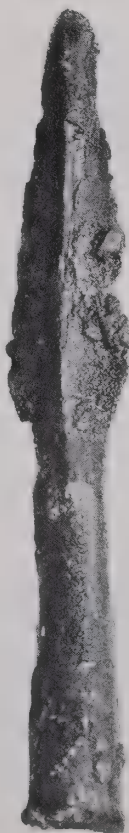

6

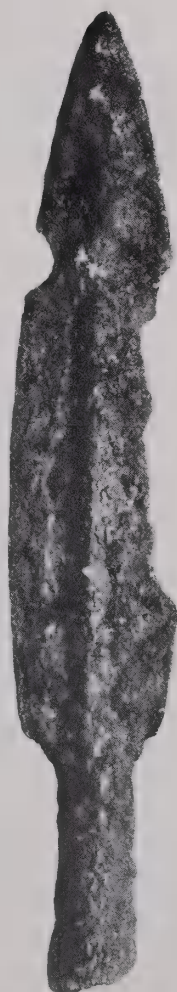

7



8



9

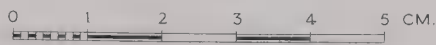

MB II OBJECTS FROM TOMB 911 D (SEE PP. 67 F.). ACTUAL SIZE

No.	Field No.	Designation	Description	Scale
TOMB 912 A 2				
1	P 3459	Jug	See Pl. 33:9	1:5
2	P 3460	Jar	See Pl. 33:11	1:5
3	P 3548	"Teapot"	See Pl. 33:10	1:5
4	M 2969	Dagger blade	Intact, t. .007, copper (see p. 161 for analysis), central rib, 3 rivets for attachment to haft (Fig. 171:2)	2:5
5	M 2977	?	Intact, t. .010, basalt	1:1
6	M 2976	Pin	Copper (see p. 161 for analysis)	1:1
TOMB 912 A 1				
7	P 3424	Bowl	Many predominantly light grits, brown ocher 2	1:5
8	P 3423	Bowl	See Pl. 32:21	1:5
9	P 3427	Bowl	See Pl. 32:20	1:5
10	P 3426	Bowl	See Pl. 32:13	1:5
11	P 3430	Lamp	Many mixed grits, burnt umber 2	1:5
12	P 3453	Bowl	See Pl. 32:22	1:5
13	P 3455	Jar	See Pl. 33:8	1:5
14	P 3447	Jug	See Pl. 33:1	1:5
15	P 3441	Jug	Few minute dark grits, Naples yellow 1, vertical shaving	1:5
16	P 3454	Jug	See Pl. 33:5	1:5
17	P 3445	Jug	See Pl. 33:4	1:5
18	M 2971	Bowl	"Bronze" (Fig. 186:5)	2:5
19	M 2972	Bowl	Intact, "bronze"; found in No. 12	2:5
20	M 2968	Arrowhead	Intact, t. .007, "bronze," central rib	2:5
21	M 2970	Knife blade	Intact, t. .006, "bronze," slight central rib	2:5
	M 2973	Shell	LB II	
	M 3191	Plate	Basalt, 1 handle (Fig. 77); LB II	

TOMB 912 A2

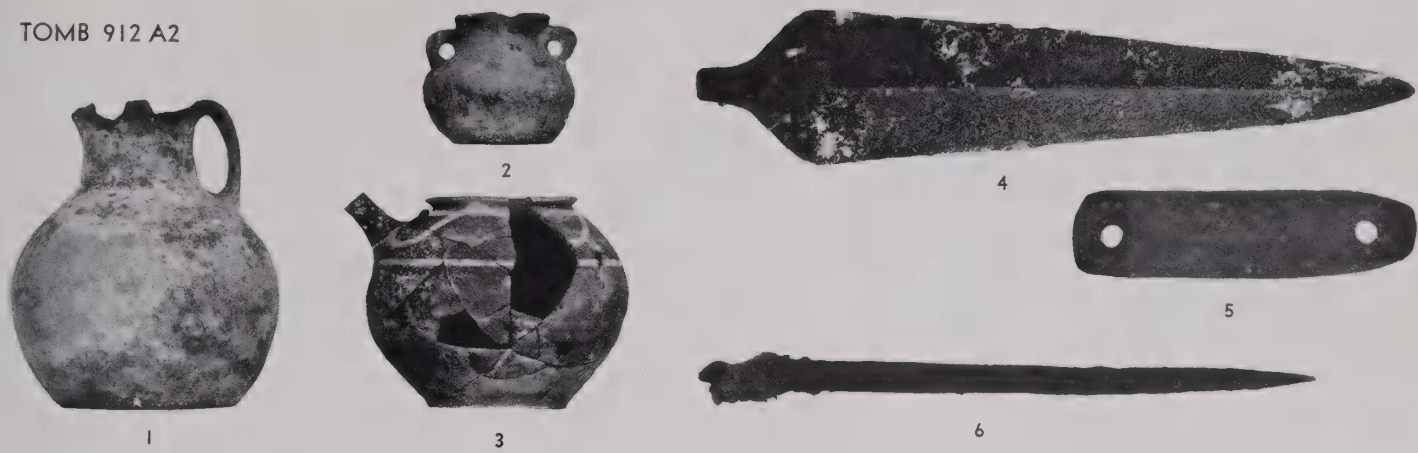

TOMB 912 A1



MB I OBJECTS FROM TOMB 912 A 2 AND LB II OBJECTS FROM TOMB 912 A 1 (SEE PP. 69-72)

No.	Field No.	Designation	Description	Date
1	P 3530	Bowl	See Pl. 35:1	MB II
2	P 3534	Bowl	See Pl. 35:2	MB II
3	P 3508	Bowl	See Pl. 35:3	MB II
4	P 3542	Jug	See Pl. 35:10	MB II
5	P 3532	Jug	See Pl. 35:7	MB II
6	P 3507	Jug	See Pl. 35:6	MB II
7	P 3541	Jar	See Pl. 35:5	MB II
8	P 3516	Bowl	See Pl. 34:9 and p. 157	LB II
9	P 3536	Jug	See Pl. 34:19	LB II
10	P 3500	Jug	See Pl. 34:18	LB II
11	P 3523	Jug	See Pl. 34:17	LB II
12	P 3513	Bowl	See Pl. 34:7	LB II
13	P 3568	Stirrup cup	Fine ware, few minute light grits, well made, brown ocher 3, close horizontal burnish- ing, indian red 2 decoration; Mycenaean	LB II
14	P 3509	Flask	See Pl. 34:14	LB II
15	P 3566	Flask	See Pl. 34:16	LB II
16	P 3521	Chalice	See Pl. 34:12	LB II
17	P 3502	Chalice	See Pl. 34:11	LB II
18	P 3520	Stirrup cup	See Pl. 34:21	LB II
19	P 3512	Jar-stand	See Pl. 34:20	LB II
20	M 3041	Bowl	"Bronze"	LB II (cf. Fig. 186:6)
21	M 3017	Bowl	"Bronze"	LB II (cf. Fig. 186:6)
22	M 3015	Bowl	Intact, "bronze"	LB II (cf. Fig. 186:7)



MB II AND LB II VESSELS FROM TOMB 912 B (SEE PP. 69-72). SCALE, POTTERY 1:5; "BRONZE" 2:5

No.	Field No.	Designation	Description	Date
1	M 3078	Saucer	Distorted (Fig. 186:1)	MB II or LB II
2	M 3047	Saucer	Intact (Fig. 186:2)	MB II or LB II
3	M 3066	Dagger blade	Intact, t. .006, end of tang bent over	LB II (cf. Fig. 171:11-13)
4	M 3076	Dagger blade	T. .006	LB II (cf. Fig. 171:11-13)
5	M 3075	Dagger blade	T. .004	LB II (cf. Fig. 171:11-13)
6	M 3082	Scale-pan?	Found upside down above No. 7, with wood fragments between them	MB II or LB II
7	M 3080	Scale-pan?	Found upside down above wood fragments and below No. 6 with wood fragments between them	MB II or LB II
8	M 3016	Scale-pan?		MB II or LB II
9	M 3046	Scale-pan?		MB II or LB II
10	M 3134	Tongs	Complete, t. .020, wood fragments underneath (grain parallel to arms)	MB II or LB II
11	M 3081	Tongs	Intact, t. .008	MB II or LB II
12	M 3042	Spearhead	Remains of "bronze" clasp over socketed end	MB II (cf. Fig. 170:3-4)
13	M 3044	Knife blade	Intact, t. .005, end of tang bent over; wood fragments near handle end	LB II (cf. Figs. 171:11-13 and 172:1)
14	M 3065	Knife blade	Same as No. 13	LB II (cf. Figs. 171:11-13 and 172:1)
15	M 3045	Knife blade	Complete, t. .007; same as No. 13	LB II (cf. Figs. 171:11-13 and 172:1)



0 5 10 15 CM.

MB II AND LB II "BRONZE" OBJECTS FROM TOMB 912 B (SEE PP. 69-72). SCALE, 2:5

No.	Field No.	Designation	Description	Date
1	M 3071	Hook	Intact	MB II or LB II
2	M 3167	Tweezers	Intact, t. .005	MB II or LB II
3	M 3077	Borer	Intact, square in section	MB II or LB II
4	M 3040	Pin		MB II or LB II
5	M 3067	Arrowhead	Blunt, fluted, tang missing	LB II*
6	M 3036	Arrowhead	Same as No. 5	LB II*
7	M 3020	Arrowhead	Intact, blunt, traces of wood shaft on tang	LB II*
8	M 3019	Arrowhead	Same as No. 7	LB II*
9	M 3043	Arrowhead	Intact, blunt, octagonal cone-shaped head	LB II*
10	M 3021	Toggle pin	Perforated, perhaps reused as a blunt arrowhead	MB II or LB II
11	M 3072	Clasp?	Not completely closed, perhaps for use around a spearhead	MB II or LB II
12	M 3068	?		MB II or LB II
13	M 3069	Spoon?	.012 high	MB II or LB II
14	M 3079	?	Doubtful whether the 2 fragments belong together	MB II or LB II
15	M 3030	?	Found in P 3539 (see opp. Pl. 35)	MB II or LB II

\* Dated by parallels from the tell. Cf. also *Beth-Pelet* II, Pl. LV 266-67 (19th-20th dynasty); Petrie, *Gaza* III, Pl. XVII 162-63 (early 18th dynasty); Macalister, *Gezer* III, Pl. LXXV 19-20 (Third Semitic period).

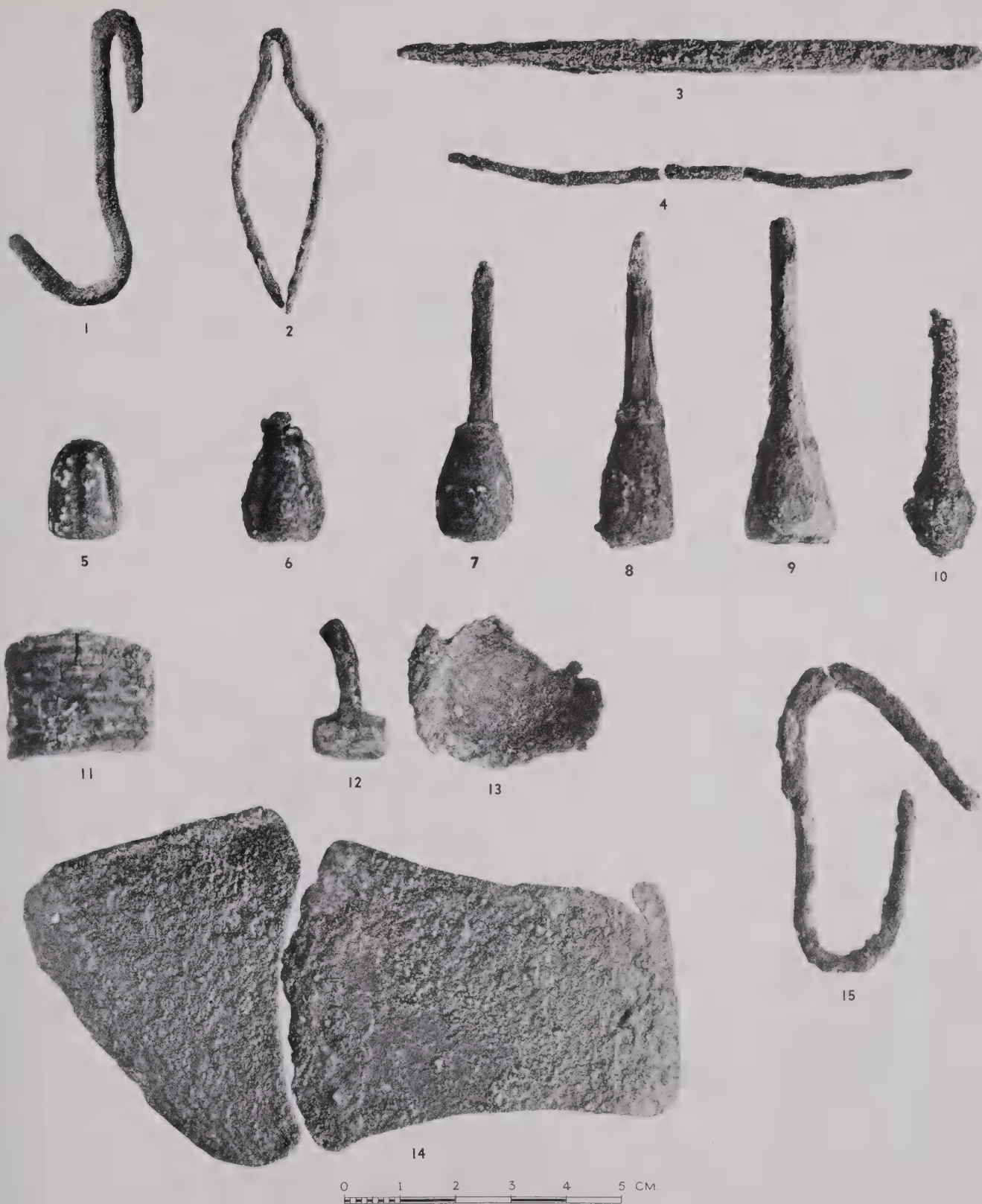

"BRONZE" OBJECTS FROM TOMB 912 B (SEE PP. 69-72). ACTUAL SIZE

No.	Field No.	Designation	Description
1	M 3086	Ear-stud?	Intact, t. .013 (cf. Petrie, <i>Objects of Daily Use</i> , Pl. XVII 37-38)
2	M 3018	Bracelet	Intact (Fig. 179:4)
3	M 3074	Bracelet	
4	M 3029	Bracelet	Found in P 3539 (see opp. Pl. 35) (Fig. 179:5)
5	M 3027	Buckle?	Intact, pointed ends (cf. Macalister, <i>Gezer III</i> , Pl. LXXV 17)
6	M 3031	Chains	Perhaps parts of scales
7	M 3073	Chisel	Intact

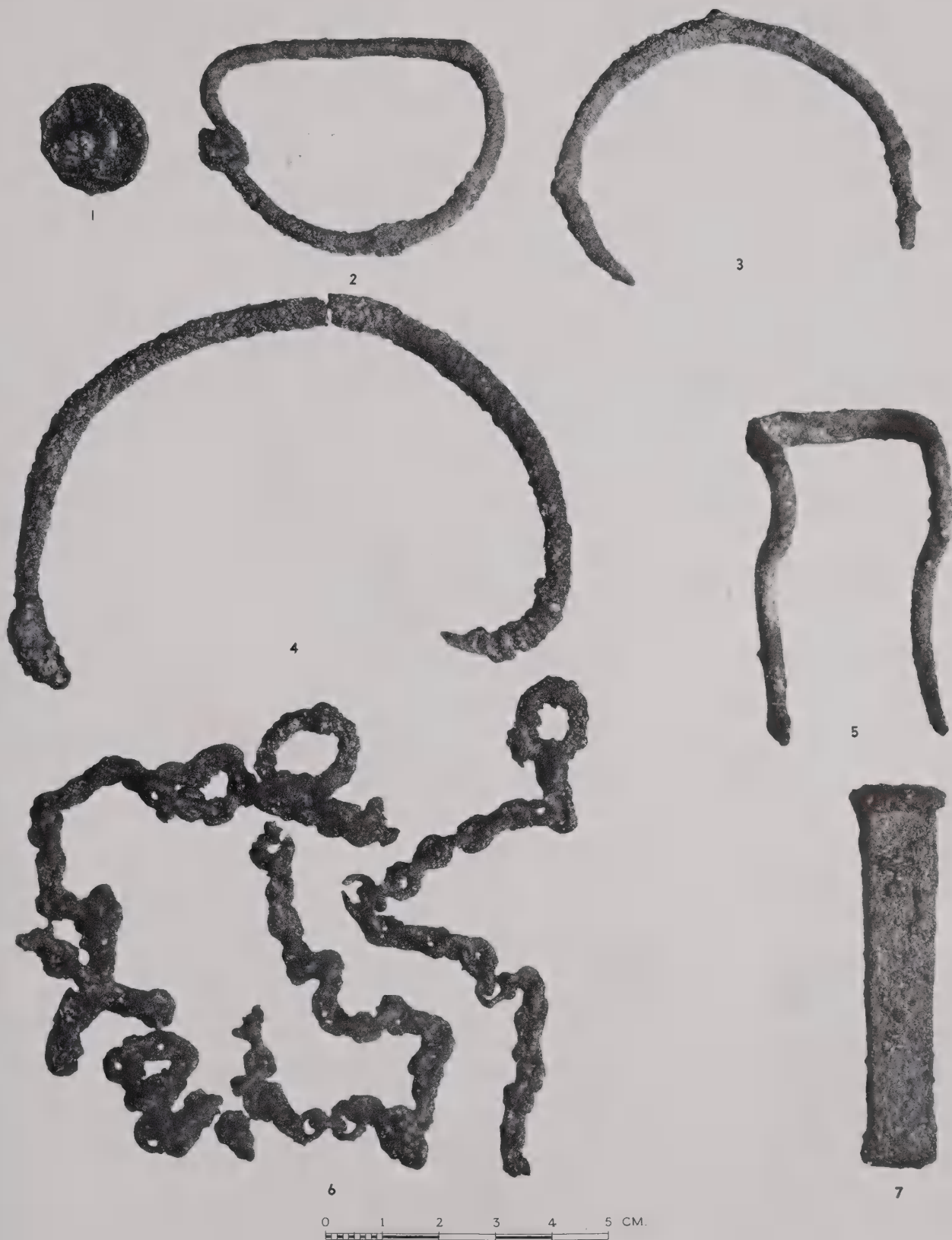

MB II or LB II "BRONZE" OBJECTS FROM TOMB 912 B (SEE PP. 69-72). ACTUAL SIZE

No.	Field No.	Designation	Description	Date
1	M 2989	Earring	Intact, gold	LB II (cf. Fig. 178:3)
2	M 2990	Earring	Intact, gold	LB II (cf. Fig. 178:3)
3	M 3098	Earring	Intact, gold	LB II (cf. Fig. 178:3)
4	M 3121	Earring	Intact, gold	LB II (cf. Fig. 178:3)
5	M 3099	Earring	Intact, silver	LB II (cf. Fig. 178:3)
6	M 3039	Earring	"Bronze" (see p. 177)	MB II or LB II
7	M 3087	Earring	Intact, "bronze" (Fig. 178:2)	MB II or LB II
8	M 3170	Earring	Intact, "bronze" (see p. 177)	MB II or LB II
9	M 3051	Plaque	Intact, t. .0001, gold foil	MB II or LB II
10	M 2974	Plaque	Intact, t. .0001, gold foil	MB II or LB II
11	M 2975	Plaque	T. .0001, gold foil	MB II or LB II
12	M 3032	Figurine	T. .025, "bronze," hollow; sheep(?) (cf. Schaeffer in <i>ILN</i> , Nov. 21, 1931, p. 806, Fig. 1)	MB II or LB II
13	M 3070	Figurine	T. .030, "bronze," hollow; cow(?) (cf. <i>ibid.</i> )	MB II or LB II
14	M 3093	Figurine	T. .023, hematite; sheep(?)	MB II or LB II
15	M 2992	Ring	Intact, gold, incised decoration containing Old Canaanite characters (see pp. 174-76)	LB II
16	M 3038	Ring	Intact, .013 wide, "bronze," found on finger bone as shown	MB II or LB II
17	M 3037	Ring	"Bronze"	MB II or LB II
18	M 3035	Ring	"Bronze"	MB II or LB II
19	M 3094	Ring	Intact, iron (Fig. 176:7)	LB II (see p. 162)

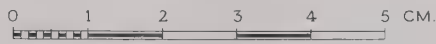
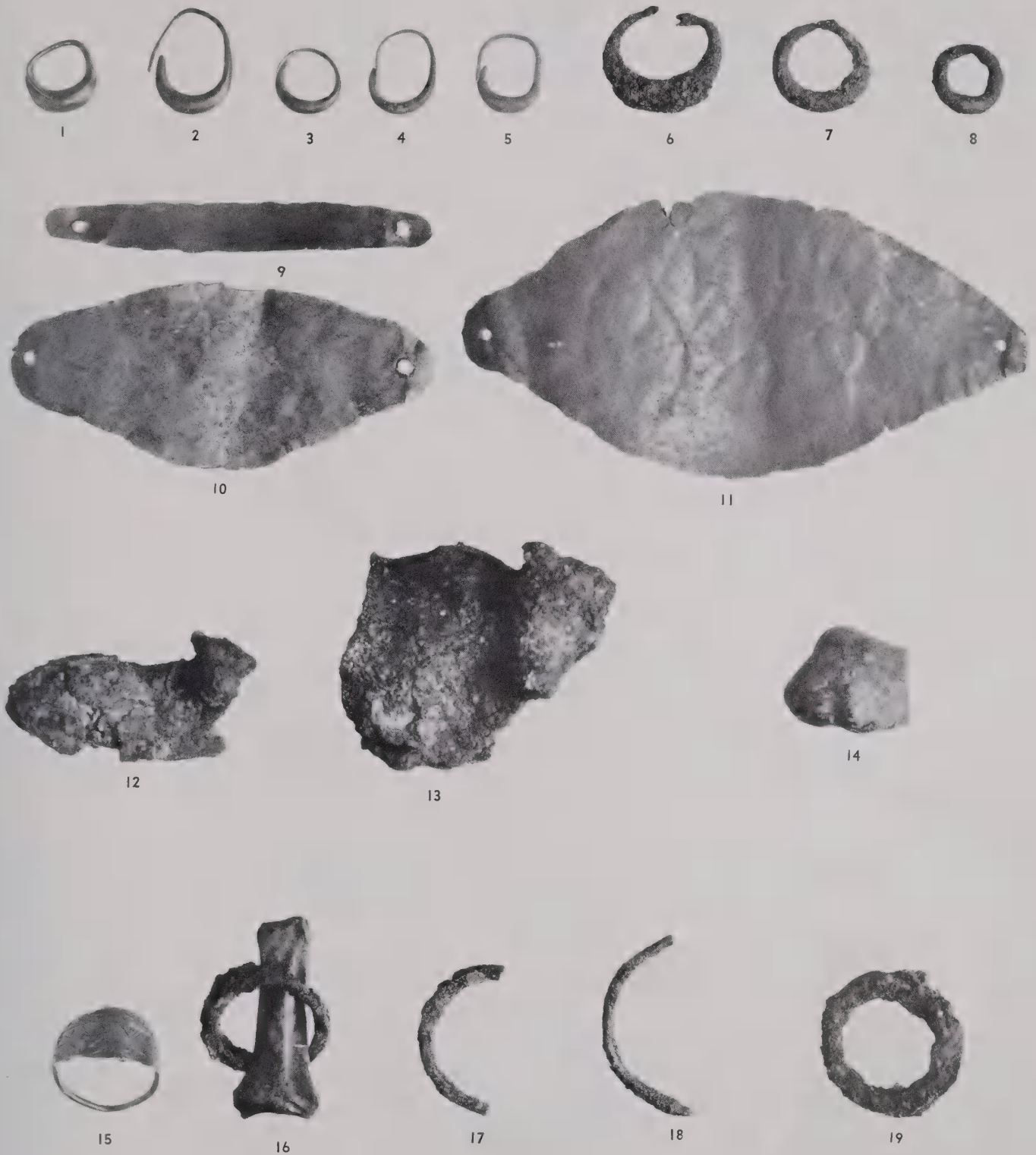

OBJECTS FROM TOMB 912 B (SEE PP. 69-72). ACTUAL SIZE

No.	Field No.	Description
1	M 3090	Intact but oxidized, "bronze," 3.2 gr., poor criterion
2	M 3024	Intact but oxidized, "bronze," 6.5 gr., poor criterion
3	M 3139	Intact but oxidized, "bronze," 6.8 gr., fair criterion
4	M 3034	Intact but oxidized, "bronze," 8.2 gr., poor criterion
5	M 3026	Intact but oxidized, "bronze," 20.4 gr., poor criterion
6	M 3025	Intact but oxidized, "bronze," 21.3 gr., small hole in base, no criterion
7	M 3022	Intact but oxidized, "bronze," 51.4 gr., small hole in base, poor criterion
8	M 3023	Intact but oxidized, "bronze," 52.9 gr., small hole in base, poor criterion
9	M 3028	Intact but oxidized, "bronze," 92.4 gr., poor criterion; found in P 3539 (see opp. Pl. 35)
10	M 3033	Intact but oxidized, "bronze," 99.4 gr., poor criterion; found in P 3533 (see opp. Pl. 34)
11	M 3091	Intact, hematite, .7 gr., good criterion
12	M 3140	Intact(?), hematite, 1.8 gr., fair criterion
13	M 3060	Hematite, 1.8 gr., fair criterion
14	M 3136	Intact(?), hematite, 2.5 gr., fair criterion
15	M 3142	Intact, hematite, 2.8 gr., good criterion
16	M 3141	Intact, hematite, 3.2 gr., good criterion
17	M 3137	Intact(?), hematite, 3.4 gr., fair criterion
18	M 3084	Intact, hematite, 3.8 gr., good criterion
19	M 3083	Intact, hematite, 3.4 gr., good criterion
20	M 3054	Intact(?), hematite, 3.9 gr., fair criterion
21	M 3085	Hematite, 7.7 gr., poor criterion
22	M 3143	Intact, hematite, 8.3 gr., good criterion
23	M 3058	Intact(?), hematite, 9.4 gr., good criterion
24	M 3057	Hematite, 12.6 gr., fair criterion
25	M 3089	Intact(?), hematite, 12.1 gr., fair criterion
26	M 3059	Intact(?), hematite, 12.5 gr., fair criterion
27	M 3056	Chert, 27.3 gr., no criterion
28	M 3055	Hematite, 46.3 gr., no criterion

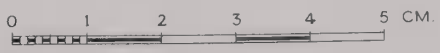

MB II OR LB II WEIGHTS (SEE P. 7) FROM TOMB 912 B (SEE PP. 69-72). ACTUAL SIZE

No.	Field No.	Designation	Description	Date
1	M 2979	Shell	T. .011	MB II or LB II
2	M 3063	Shell	T. .012	MB II or LB II
3	M 3062	Shells		MB II or LB II
4	M 3106	Inlays?	Bone, incised decoration, furniture inlays? (fragments of wood furniture found in the tomb)	LB II
5	M 3151			
6	M 3152			
7	M 3153			
8	M 3092	?	T. .012, fayence, traces of cobalt green 3 glaze	MB II or LB II
9	M 3064	?	Fayence, traces of cobalt green 3 glaze	MB II or LB II
10	M 2978	Rubber	T. .016, hematite	MB II or LB II
11	M 3158	Rubber	Intact, basalt	MB II or LB II
12	M 3150	Whetstone	Sandstone	MB II or LB II
13	M 3048	Vessel	Egyptian "alabaster" (Fig. 184:10)	LB II (see p. 189)
14	M 3049	Vessel	Egyptian "alabaster" (Fig. 184:11)	LB II (see pp. 186 and 189)
15	M 3052	Vessel	Fayence, white and cobalt green 3 glaze (Fig. 185:1)	MB II or LB II

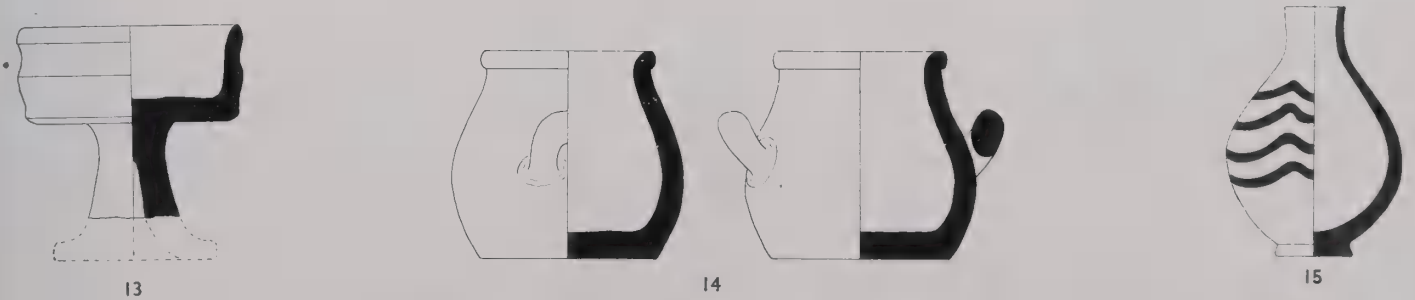
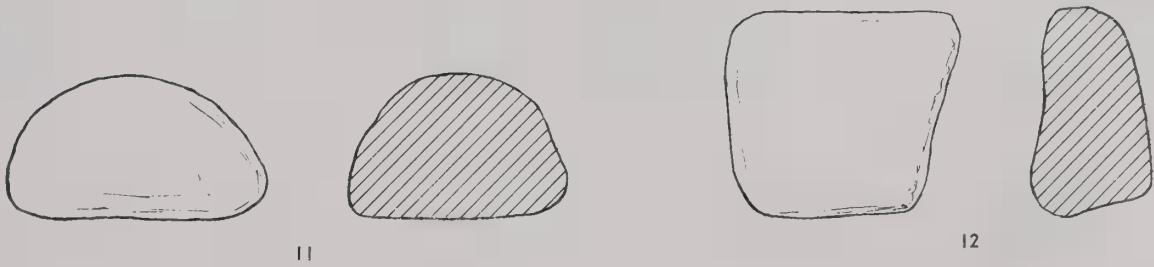
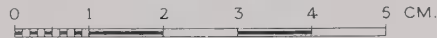
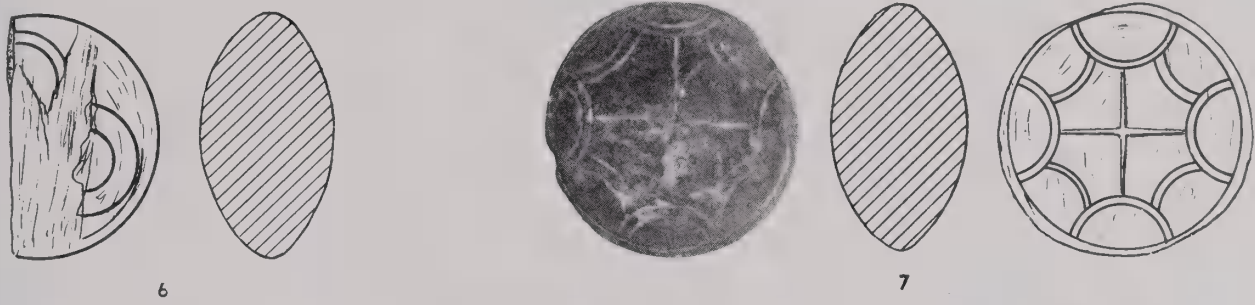

OBJECTS FROM TOMB 912 B (SEE PP. 69-72). SCALE, 1:1 (Nos. 1-10) AND 2:5 (Nos. 11-15)

No.	Field No.	Designation	Description	Date
1	M 3095	Scarab	Intact, carnelian, traces of silver ring, inscribed with figures of Ptah and Sekhmet (but with horns of Hathor added to her sun disk and carrying basket of Bastet) (Rowe, <i>Scarabs</i> , No. 719)	LB II
2	M 3132	Scarab	Fayence, traces of dark blue glaze, inscription defaced	MB II or LB II
3	M 3096	Scarab	Intact, fayence, prussian green 3 glaze, inscribed with figure of king worshipping Ptah, style of Ramses II, but king's name (if intended at top) illegible (Rowe, <i>Scarabs</i> , No. 726; cf. Hall, <i>Scarabs</i> , Nos. 2193-2201). Rowe reads "Amon-Re" between figures and "lord of the phallus" above them, which suit his drawing but seem strange in association with Ptah.	LB II
4	M 2984	Scarab	Intact, fayence, traces of prussian green 1 glaze, inscribed with prenomen of Thutmose III ( <i>Mn-hpr-Rc</i> ) between feathers (Rowe, <i>Scarabs</i> , No. 490; cf. Newberry, <i>Scarabs</i> , Pl. XXIX 35)	LB II
5	M 2988	Scarab	Steatite, inscribed with <i>ntr nfr nb t3wy</i> ("Good god, lord of the Two Lands") and cartouche of Thutmose III ( <i>Mn-hpr-Rc</i> ) before a seated figure of the king with scepter (Rowe, <i>Scarabs</i> , No. 493)	LB II
6	M 2983	Scarab	Intact, steatite, inscribed with prenomen of Ramses II ( <i>Wsr-m34-Rc stp-n-Rc</i> ) and falcon-headed figure of Re (Rowe, <i>Scarabs</i> , No. 664; cf. Hall, <i>Scarabs</i> , Nos. 2170-75)	LB II
7	M 2985	Scarab	Steatite, decorated gold setting, inscribed with "gold" and <i>nfr</i> ("beauty" or "goodness") signs within border (Rowe, <i>Scarabs</i> , No. 610)	MB II or LB II
8	M 2986	Scarabs	Steatite, traces of cerulean blue 3 glaze, purely decorative design (Rowe, <i>Scarabs</i> , No. 625)	MB II or LB II
9	M 2987	Scarab	Complete, steatite, gold setting, gold ring with ornamental wire, inscribed with beetle (Khepri) over crocodile (Sebek) and between winged uraei (Isis and Nephthys?) guarding sun disks (Rowe, <i>Scarabs</i> , No. 590)	MB II or LB II
10	M 2993	Scarab	Intact, steatite, traces of prussian green 3 glaze, gold setting, gold ring with ornamental wire, inscribed with <i>nfr s3 3Imn</i> ("Beautiful is the son of Amon" or "good is Siamon [son of Ramses II or a 21st dynasty king?]") and a uraeus rising before the <i>s3</i> -bird (Rowe, <i>Scarabs</i> , No. 771; cf. John Ward, <i>The Sacred Beetle</i> [London, 1902] Pl. VII 474, for an apparently later parallel)	MB II or LB II
11	M 3131	Scarab	Intact, steatite, traces of cerulean blue 3 glaze, purely decorative design (Rowe, <i>Scarabs</i> , No. 626)	MB II or LB II
12	M 3114	Scaraboid	Fayence, gold setting, mesh pattern on base (Rowe, <i>Scarabs</i> , No. SO. 10)	MB II or LB II
13	M 3119	Scarab	Intact, quartz, base uninscribed (Rowe, <i>Scarabs</i> , No. 805)	MB II or LB II
14	M 3190	Scaraboid	Carnelian, base uninscribed (Rowe, <i>Scarabs</i> , No. SO. 11)	MB II or LB II
15	M 3097	Cylinder seal	Intact, fayence	LB II (see pp. 182-84)



0 1 2 3 4 5 CM.

OBJECTS FROM TOMB 912 B (SEE PP. 69-72). ACTUAL SIZE

No.	Field No.	Designation	Description	Date
1	M 3154	Whorl	Intact, t. .005, steatite	LB II (cf. Fig. 175)
2	M 3127	Whorl	Intact, t. .005, bone	LB II (cf. Fig. 175)
3	M 3124	Whorl	Intact, t. .004, bone	LB II (cf. Fig. 175)
4	M 3123	Whorl	Intact, t. .006, bone	LB II (cf. Fig. 175)
5	M 3061	Whorl	Intact, t. .004, bone	LB II (cf. Fig. 175)
6	M 3108	Inlay	T. .012, glass, ultramarine ash blue 3 and naples yellow 3	MB II or LB II
7	M 2991	Inlay	T. .006; same as No. 6	MB II or LB II
8	M 3138	Inlay	Same as No. 7	MB II or LB II
9	M 3110	Inlay	Intact, t. .004, fayence, indian red 3	MB II or LB II
10	M 2997	Pendant	Intact, carnelian; lotus seed-vessel	LB II (cf. Pl. 95:27)
11	M 3144	Gaming-pieces?	Limestone, traces of cerulean blue 3 glaze	MB II or LB II
12	M 3000	Beads	Carnelian, (a) short barrel, (b) short truncated bicone	MB II or LB II
13	M 3006	Beads	Carnelian, standard barrel	MB II or LB II
14	M 3013	Beads	Carnelian, (a) long barrel, (b) standard barrel	MB II or LB II
15	M 3010	Beads	Carnelian, (a) short truncated convex bicone, (b) standard barrel, (c) circular (d) oblate	MB II or LB II
16	M 2999	Beads	Carnelian, (a) long barrel, (b) long truncated bicone	MB II or LB II
17	M 3004	Beads	Carnelian, short truncated convex bicone	MB II or LB II
18	M 3107	Bead	Carnelian, irregular short barrel	MB II or LB II
19	M 3011	Bead	T. .007, carnelian, irregular long barrel lenticular	MB II or LB II
20	M 3012	Bead	Intact, t. .005, carnelian, long truncated bicone lenticular	MB II or LB II
21	M 3007	Beads	Carnelian, short cylinder	MB II or LB II
22	M 3003	Beads	Glass, ultramarine ash blue 3, irregular oblate	MB II or LB II
23	M 3156	Beads	T. .004, glass, ultramarine ash blue 3, standard pear shape lenticular	MB II or LB II
24	M 3103	Bead	Glass, striated permanent yellow 3 and ultramarine ash blue 3, irregular long cylinder	MB II or LB II
25	M 3133	Bead	Glass, davy's gray 3, long cylinder with one convex end, perforated both ways	MB II or LB II
26	M 3100	Bead	Intact, .004 long, glass, blue-black 3, gadrooned short truncated convex cone	MB II or LB II
27	M 3122	Bead	Intact, .004 long, glass, ultramarine ash blue 1, gadrooned short truncated convex cone	MB II or LB II
28	M 3115	Beads	Quartz, (a) short barrel, (b) gadrooned standard barrel, (c) gadrooned oblate	MB II or LB II
29	M 3118	Bead	Intact, quartz, short barrel	MB II or LB II
30	M 3111	Bead	.006 long, serpentine, double-chamfered cylinder disk	MB II or LB II
31	M 3155	Beads	Stone, (a) long barrel, (b) long truncated convex bicone	MB II or LB II
32	M 3008	Beads	Gold, (a) long barrel, (b) short barrel	MB II or LB II
33	M 3009	Bead	Intact, silver, long cylinder	MB II or LB II
	M 3112	Wire	Silver, twisted	MB II or LB II

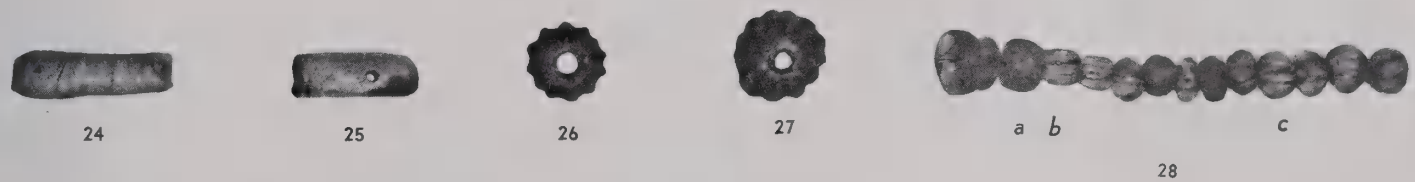
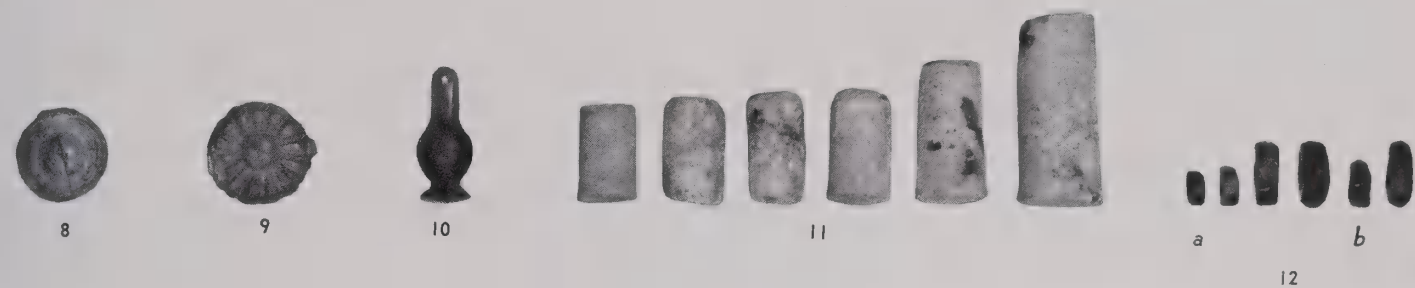
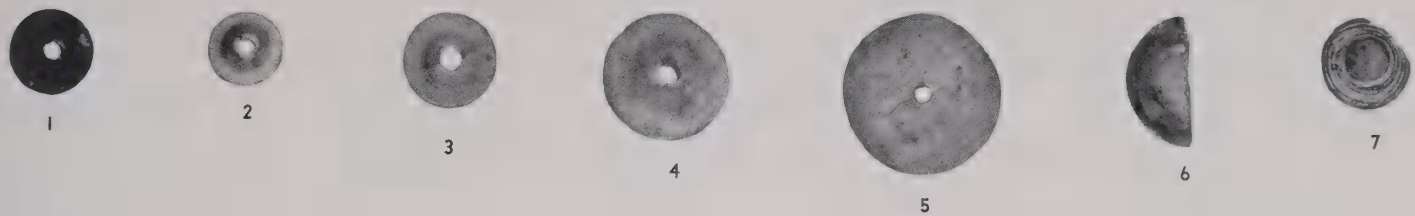

OBJECTS FROM TOMB 912 B (SEE PP. 69-72). ACTUAL SIZE

No.	Field No.	Designation	Description	Date
1	P 3504	Jug	Well made, brown ocher 2, indian red 3 decoration	MB II
2	P 3464	Jug	See Pl. 35:18	MB II
3	P 3483	Jug	See Pl. 35:19	MB II
4	M 2966	Axhead	Intact, "bronze," short bar over top of socket perhaps for split haft (cf. AAA XIX, Pl. XXXVII 3)	MB II (see p. 167)
5	M 2958	Dagger blade	T. .003, copper (see p. 161 for analysis), 3 rivets for attachment to haft	MB II
6	M 2959	Dagger blade	Intact, t. .006, bronze (see p. 161 for analysis), 3 rivets for attachment to haft	MB II
7	M 2957	Spearhead	Intact, t. .005, bronze (see p. 161 for analysis), bronze clasp over socket end	MB II (cf. Fig. 170:3-4)
	M 2961-62	Dagger pommels	Limestone; same type as Pl. 118:2	MB II (see p. 164)
8	P 3484	Bowl	See Pl. 35:30	LB II
9	P 3467	Jar	See Pl. 35:21	LB II
10	P 3478	Jug	See Pl. 35:27	LB II
11	P 3469	Cooking bowl	See Pl. 36:7	LB II
12	P 3461	Jar	See Pl. 35:26	LB II
13	P 3471	Funnel	See Pl. 35:23	LB II
14	P 3487	Jar-stand	See Pl. 35:20	LB II
15	P 3474	Chalice	See Pl. 35:28	LB II
16	P 3482	Lamp	See Pl. 35:29	LB II
17	P 3498	Milk bowl	See Pl. 35:25	LB II
18	P 3559	"Cup and saucer"	See Pl. 35:24	LB II
19	M 2960	Bowl	Intact, "bronze" (Fig. 186:7)	LB II
20	M 2967	Dagger blade	Intact, t. .005, bronze (see p. 161 for analysis)	LB II (cf. Fig. 171:11-13)
21	M 2965	Bracelet	"Bronze," fastened by entwining wire (Fig. 179:3); found in P 3466 (Pl. 35:14)	MB II or LB II



1



2



3

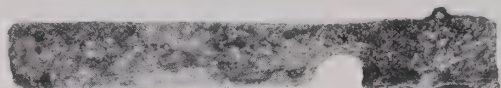

4

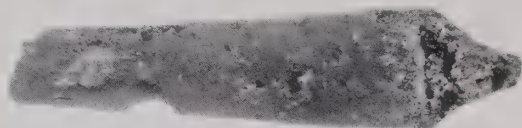

5

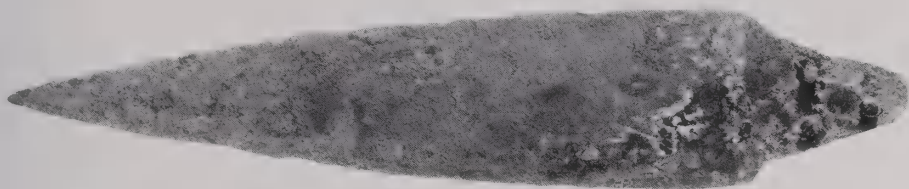

6



7



8

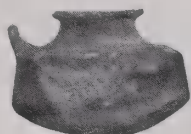

9

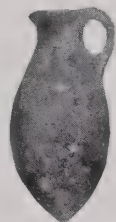

10



14



12

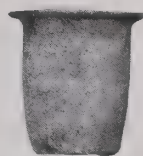

13

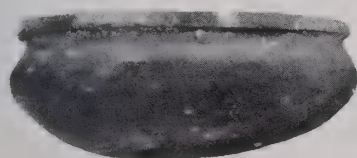

11

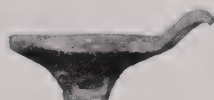

17

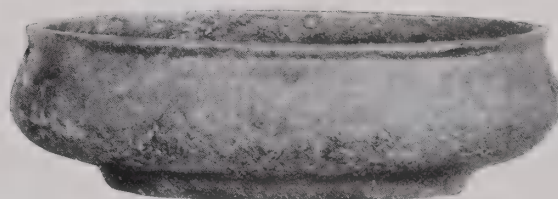

19

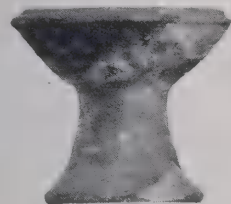

15

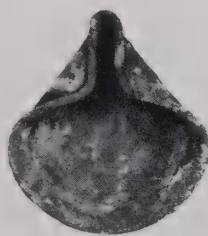

16

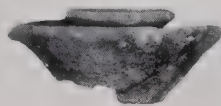

18

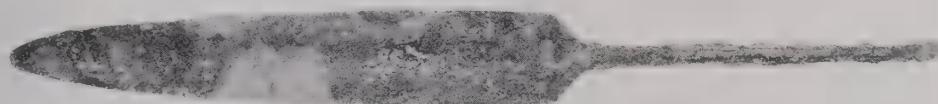

20



21

MB II AND LB II OBJECTS FROM TOMB 912 D (SEE PP. 69-72). SCALE, POTTERY 1:5; METAL 1:2

Field No.	Designation	Description	Date
P 3317	Jug	Intact, few light grits, well made, brown ocher 3 surface, naples yellow 1 slip, light red 2 decoration (see p. 156)	LB II

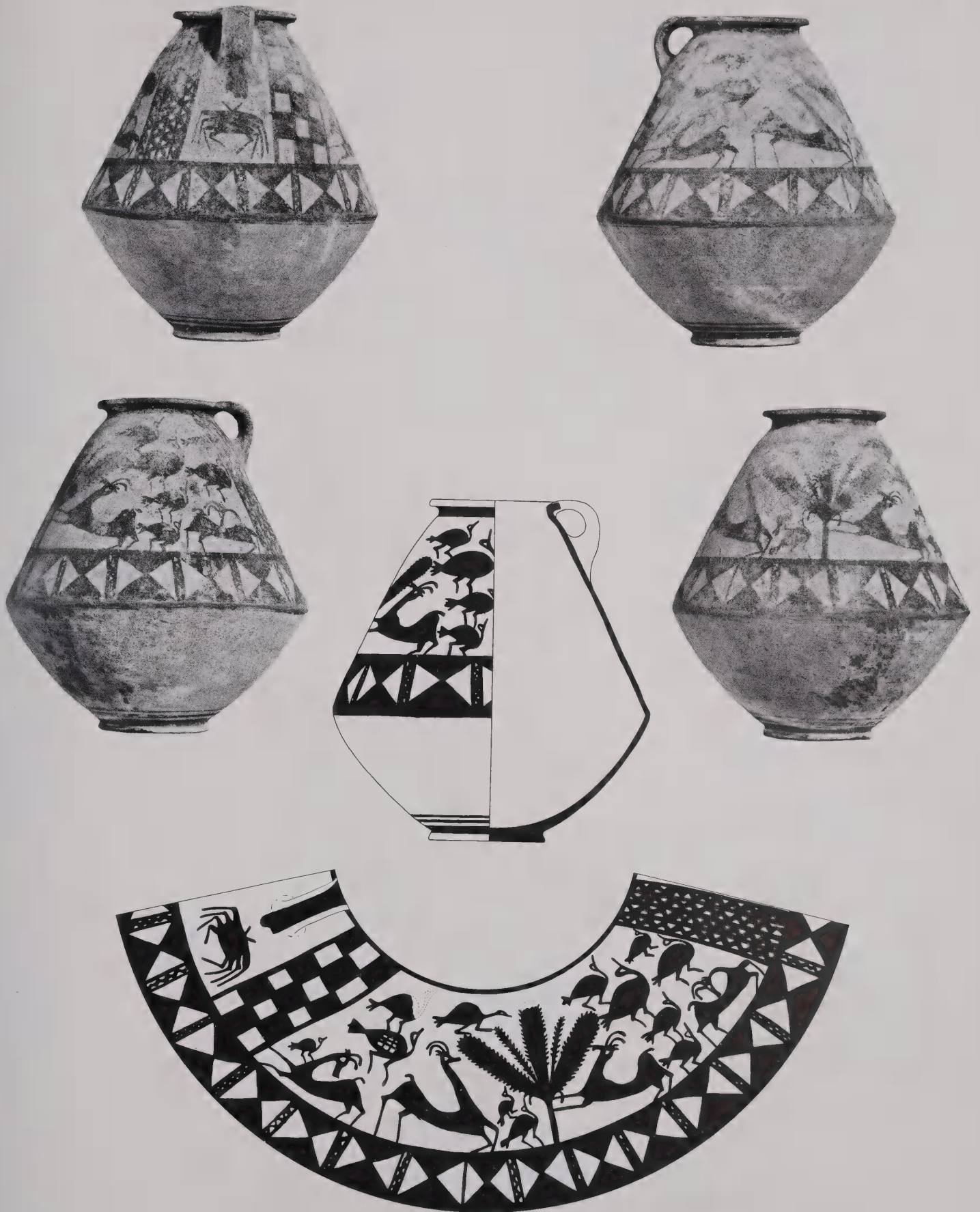

0 5 10 15 20 25 CM.

THE MEGIDDO VASE, FROM TOMB 912 D (SEE PP. 69-72). SCALE, 1:5

No.	Field No.	Designation	Description	Date
TOMB 3				
1	x 47	Jug	Brown ocher 3	LB I
2	x 46	Jug	Charcoal gray 3 core, brown ocher 3 surface	LB I
3	x 2844	Jug	Many light grits, brown ocher 3	LB I
4	x 44	Jug	Brown ocher 3	LB I
5	x 91	Milk bowl	Burnt umber 3, burnt sienna 2 decoration, handmade; Cypriote	LB II
	x 90 } x 92 }	Milk bowls	Local imitations of same type as No. 5	LB II
6	x 7	Jug	Large light grits, permanent brown 3, indian red 3 decoration	LB I
	x 96-97	Jugs	Same type as No. 6	LB I
	x 43	Jug	Brown ocher 1, reddish slip?	LB II
	x 2843	Jug	Brown ocher 1	LB II
7	x 276	Bracelet	"Bronze"	?
8	x 2845	Bowl	See Pl. 37:7	LB I
9	x 617	Earring	"Bronze"	LB II (cf. Fig. 178:3)
10	x 275	Arrowhead	"Bronze," square tang	LB II*
11	x 619	Figurine	Pottery, permanent brown 3, probably a plaque fragment, details obscure; female head	?
	x 101 } x 104 } x 107 } x 609-11 }	Rubbers	Black granite, basalt, limestone, and marble	?
	x 612	Drill-socket	Basalt; same type as Pl. 141:29	?
	x 108-10	Grinders	Basalt	?
	x 250-65	Flints		?
	x 270-74	Feluccas		?
TOMB 6				
12	x 7	Jar	Brown ocher 3	LB I
13	x 375	Lamp	Brown ocher 3	LB I
	x 2	Bowl	Burnt umber 3, 8 indian red 3 radial bars inside	LB I
	x 8	Jug	Same shape as Pl. 112:18, burnt umber 3, double handle	LB I
		Sherds		MB I and LB I
TOMB 18				
14	x 394	Jar	Egyptian "alabaster" (Fig. 184:4)	LB I
TOMB 20				
15	x 440	Beads	Intact except <i>g</i> ; ( <i>a</i> ) carnelian, short barrel; ( <i>b</i> ) carnelian, short truncated bicone; ( <i>c</i> ) chalcedony, yellowish brown, long barrel; ( <i>d</i> ) marble, short barrel; ( <i>e</i> ) glass, corroded white to iridescent (one with amber colored core), oblate; ( <i>f</i> ) shell, barrel disk; ( <i>g</i> ) glass, light blue and white, long cylinder	LB I

\* Dated on basis of recent evidence from the tell.

TOMB 3



TOMB 6



TOMB 18

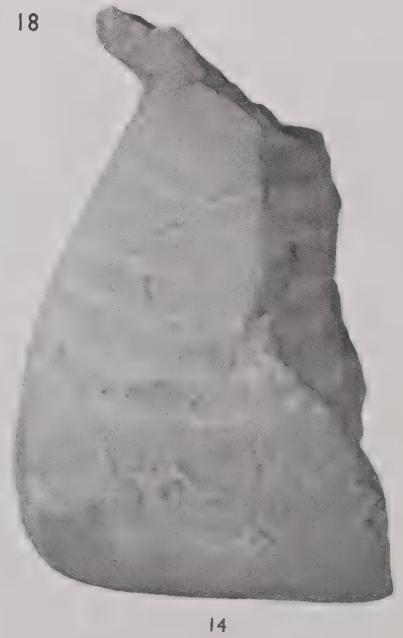

TOMB 20

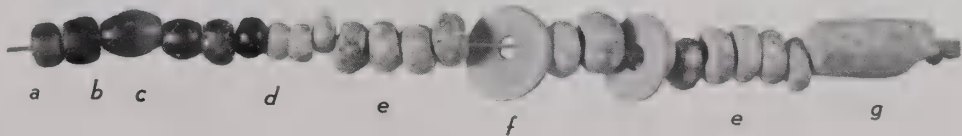

15

No.	Field No.	Designation	Description	Date
1	2812	Jug	See Pl. 38:20	LB I
2	2816	Jug	Permanent brown 3, double handle	LB I
	7051	Jug	Same type as No. 2	LB I
3	2814	Jug	Permanent brown 3, made without handle	LB I
4	7052	Jug	Naples yellow 3	LB I
	7053	Jug	Same type as No. 4	LB I
5	2813	Cup	Many mixed grits, poorly fired, permanent yellow 3	LB I
6	7054	Cup	Permanent yellow 3	LB I
7	7104	Jug	Naples yellow 3	LB I
8	7055	Jar-stand	Charcoal gray 3 core, permanent brown 1 surface	LB II?
9	02939 <i>b</i>	Jug	Large light grits, permanent yellow 3	LB I
10	7050	Jug	See Pl. 39:5	EI II
11	x 543	Jug	See Pl. 39:4	E-MI
12	x 0543	Jar	See Pl. 39:3	EI II
13	x 1916	Jug	See Pl. 39:6	EI
14	x 559	Sickle	T. .004, iron	?
15	x 522 <i>a</i>	Rubber	Basalt	?
16	x 520	Rubber	Basalt	?
17	x 531	Felueca	Reused potsherd, brown ocher 3, indian red 3 wash, burnished	?
18	x 2939	Jar	See Pl. 38:26	MI
19	x 580	Beads	( <i>a</i> ) Some intact, glass, white and light green, oblate; ( <i>b</i> ) intact, fayence, light green, long cylinder with gadrooned protuberance in center; ( <i>c</i> ) intact, carnelian, oblate; ( <i>d</i> ) intact, limestone, long cylinder, rectangular in transverse section; ( <i>e</i> ) marble, oblate; ( <i>f</i> ) "bronze," short barrel; ( <i>g</i> ) amethyst, long cylinder with convex ends	LB I? (cf. Pl.138:15-16)
20	x 594 <i>a</i>	Toggle pin	Intact but oxidized, silver, spiral and grooved decoration on head	?
21	x 594 <i>b</i>	Toggle pin	"Bronze," grooved decoration on head	LB I? (cf. Fig. 174:7-9)
22	x 595	Bead	T. .002, fayence, white, barrel disk	?
23	x 581	Ring	"Bronze"	?
24	x 593	Pin	Intact but oxidized, "bronze"	?
25	x 533	Toggle pin	"Bronze"	?



0 5 10 15 20 25 CM.

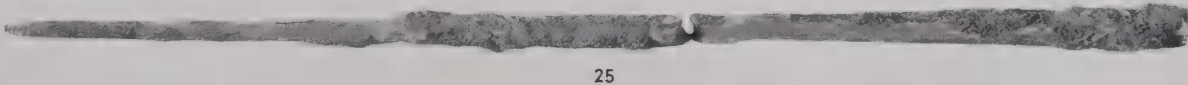
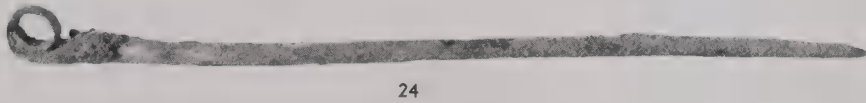
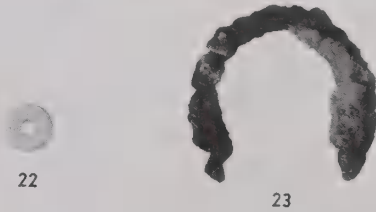
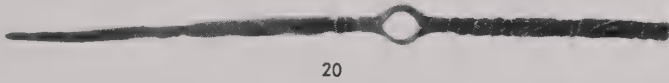
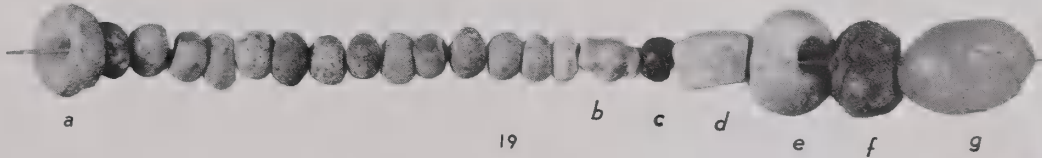

0 1 2 3 4 5 CM.

OBJECTS FROM TOMB 37 (SEE PP. 74-81). SCALE, 1:5 (NOS. 1-18) AND 1:1 (NOS. 19-25)

No.	Field No.	Designation	Description	Date
TOMB 37				
1	x 573	Scarab	Intact, steatite, purely decorative design	Hyksos
2	x 574	Scarab	Intact, steatite, purely decorative design	Hyksos
3	x 577	Scarab	Steatite, inscribed with falcon between uraei	Hyksos
4	x 578	Scarab	Steatite, inscribed with perhaps <i>k<sup>3</sup></i> -arms between <i>m<sup>3</sup>-t</i> -feathers	Hyksos
5	x 575	Scarab	Intact, steatite, traces of light blue glaze, inscribed with <i>w<sup>3</sup>d</i> ("flourish") between <i>sw</i> -plants on "gold" sign over <i>nfr</i> ("beauty" or "goodness") between "life" signs (cf. Pl. 138:14)	Hyksos
6	x 576	Scarab	Steatite, inscribed with man standing on <i>nb</i> -basket and holding a tall plant not unlike the Egyptian blue lotus, which may have been its prototype (cf. Petrie, <i>Buttons</i> , Pl. XIV 940-43)	Hyksos
7	x 579	Scarab	Steatite, inscribed with perhaps <i>dd</i> ("duration") over <i>hpr</i> ("existence") at each side and uncertain signs over 2 <i>nfr</i> ("goodness") signs over "gold" down middle, small circle(?) at each side of "gold"	Hyksos
TOMB 37 A				
8	x 5	Spearhead	"Bronze"	LB I? (cf. Fig. 170: 5-9)
9	x 2819	Jug	See Pl. 39:8	LB I
10	x 2818	Bowl	See Pl. 39:9	LB I
11	x 535	Scaraboid	Steatite, inscribed with plant decoration and <i>s<sup>3</sup>(?)</i> ("magical protection") signs	Hyksos
12	x 536	Scarab	Intact, steatite, traces of glaze, inscribed with a lion	Hyksos
13	x 537	Beads	(a) Intact but oxidized, "bronze," short barrel, collared; (b) "bronze," short barrel; (c) intact but oxidized, .011 long, "bronze," long barrel, collared, extends inside of b; (d) intact, fayence, white, oblate; (e) intact, carnelian, short barrel	LB I? (cf. Pl. 138: 15-16)
TOMB 37 B				
14	545	Bracelet	Intact but oxidized, iron; found on left arm of infant (see Fig. 90 and p. 177)	EI (see p. 77)
TOMB 37 C 2				
15	7062	Jar	Brown ocher 3	EI I

TOMB 37



1



2

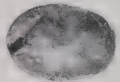
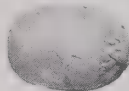
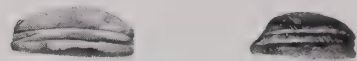

3

4



5



6



7

TOMB 37 A

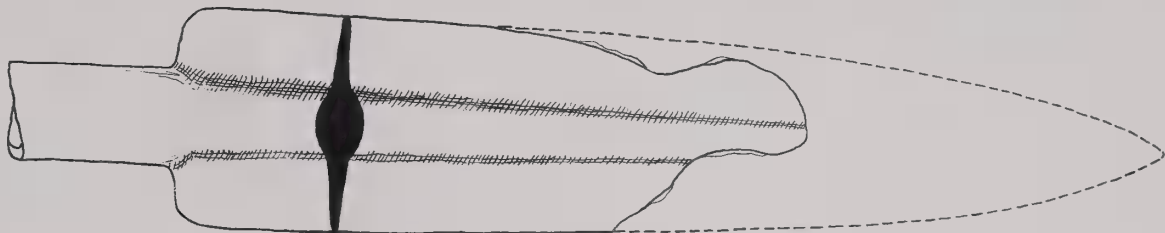
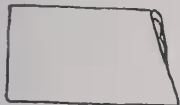

8



9

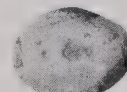
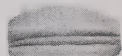

11

12

TOMB 37 C2



15



10

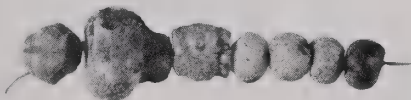

a b c a d e

13

TOMB 37 B



14

No.	Field No.	Designation	Description	Date
TOMB 37 C 2				
1	x 554	Bracelet	Intact but oxidized, "bronze," fragments of cloth adhering (Fig. 179:7)	EI I
	x 553	Bracelet	Complete; same type as No. 1	EI I
2	x 552	Bracelet	"Bronze," fragments of cloth adhering	EI I
3	x 555	Bracelet	"Bronze"	EI I
4	x 556	Bead	Intact, .006 long, shell with natural spiral, cylinder disk rectangular	EI I
5	x 557	Beads	(a) Intact, fayence, white and light green, short cylinder; (b) glass, white, long barrel	EI I
TOMB 37 E				
6	x 2940	Jar	Brown ocher 3 core, burnt umber 3 surface, burnished, sepia 3 decoration (cf. <i>OIP</i> XLII, Pl. 19, No. 105)	EI II
7	x 542	Scarab	Steatite, traces of green glaze; inscription might <i>possibly</i> be meant for  ("the King of Lower and Upper Egypt [is] in our two cities"), though the bird would make a far better <i>w</i> than <i>m</i>	?
TOMB 37 F				
8	x 02945	Jar	Poorly made, permanent brown 3 core, permanent yellow 3 surface (cf. <i>OIP</i> XLII, Pl. 11, No. 55)	MI
	x 2	Jar	Same type as No. 8	MI
TOMB 37 K 4				
9	x 548	Bowl	Permanent brown 3	LB I
10	02821	Bowl	See Pl. 40:7	LB I
11	2820	Jug	See Pl. 40:8	LB I
12	2821	Jug	See Pl. 40:9	LB I
13	x 2946	?	Pottery, charcoal gray 3 core, permanent brown 3 surface, slot made before firing, sides probably originally symmetrical but rubbed down by secondary use	LB I
14	x 546	Scarab	Intact, steatite, traces of yellow glaze, inscribed with <i>w<sup>3</sup>d</i> ("flourish") between <i>sw</i> -plants over <i>dd</i> ("duration") between "life" signs	LB I
15	x 558	Beads	(a) Intact, fayence, white, short barrel; (b) intact, marble, long barrel; (c) complete, "bronze," short barrel; (d) intact, amethyst, circular; (e) composition, blue, long cylinder	LB I
16	x 547	Beads	Intact; (a) fayence, white and light green, short barrel; (b) carnelian, short truncated bicone; (c) carnelian, short barrel	LB I
17	x 550	Peg	Intact but oxidized, "bronze," fluted head	LB I
18	x 549	Felucca	Reused potsherd, permanent brown 3 core, brown ocher 3 wash, burnished	LB I
19	x 551	Bracelet	"Bronze" (Fig. 179:2)	LB I

TOMB 37 C2



TOMB 37 E



TOMB 37 F

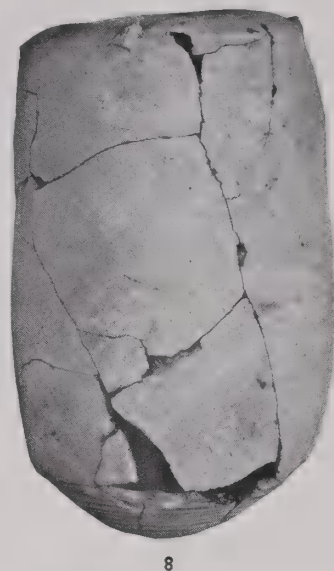

TOMB 37K4

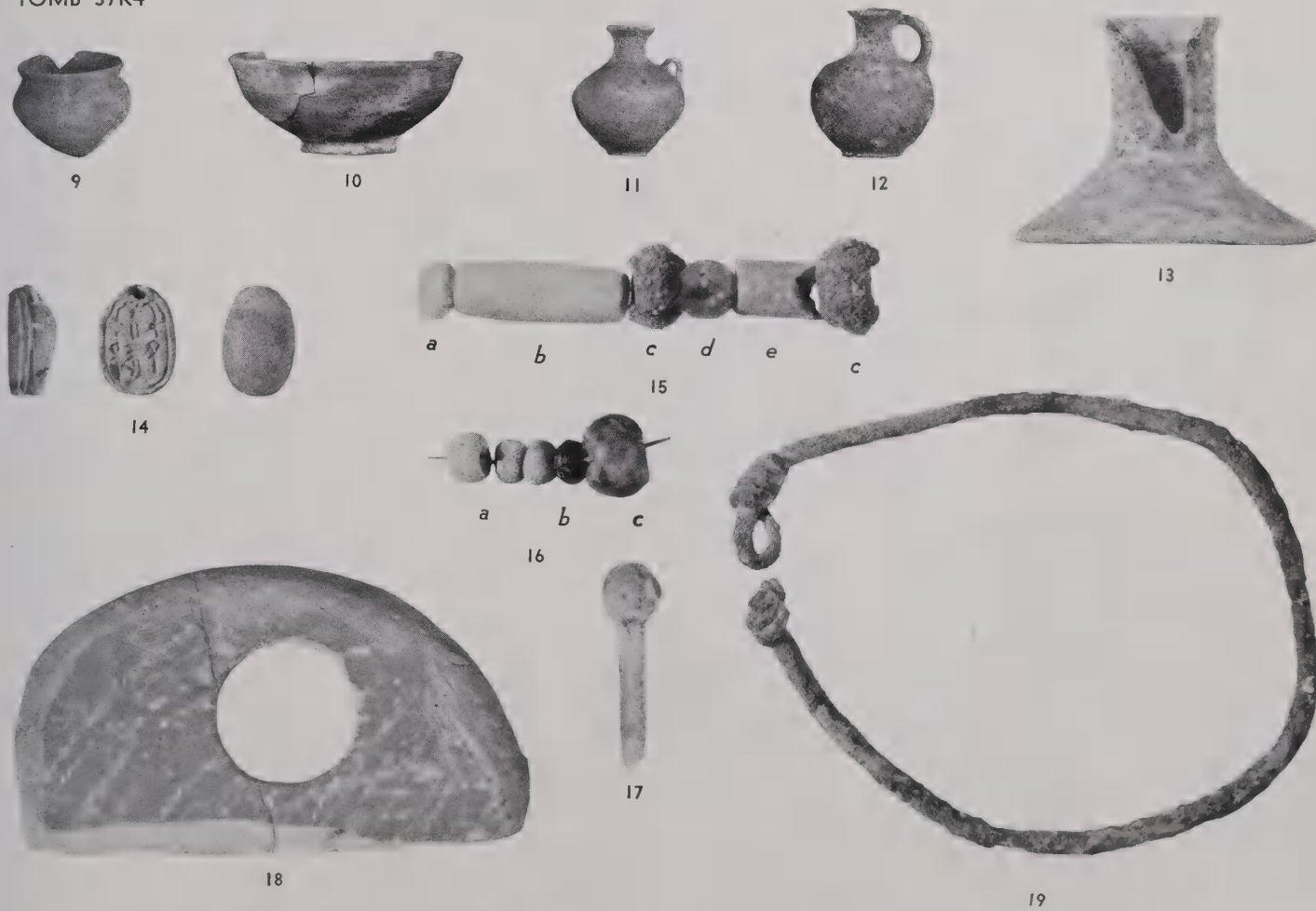

OBJECTS FROM TOMB 37 (SEE PP. 74-81). SCALE, POTTERY VESSELS (INCLUDING NO. 13) 1:5; OTHER OBJECTS ACTUAL SIZE

No.	Field No.	Designation	Description	Date
TOMB 37 M				
1	7063	Jug	Permanent yellow 1	LB I
2	02821 <i>b</i>	Jug	Brown ocher 3 core, permanent brown 3 surface	LB I
3	2822	Jug	Brown ocher 3, indian red 3 decoration	LB I
4	2823	Jug	Brown ocher 3	LB I
5	02946	Jug	Brown ocher 3	LB I
6	02821 <i>a</i>	Jug	Same as No. 2	LB I
7	7064	Jug	Blue-black 3 core, brown ocher 3 surface	LB I
	7065	Jar	Same type as Pl. 41:26	LB I
TOMB 37 N				
8	x 7066	Jar	Poorly made, permanent yellow 3 (cf. <i>OIP</i> XLII, Pl. 11, No. 55)	MI
		Jars	Same type as No. 8 (Fig. 94)	MI
TOMB 38				
9	x 3365	Bowl	Brown ocher 3	LB I
10	x 3366	Bowl	See Pl. 40:16	LB I
11	x 143	Lamp	Brown ocher 3	LB I
12	x 144	Lamp	Brown ocher 3	LB I
13	x 3352	Bowl	Brown ocher 3	LB I
14	x 03355	Bowl	Brown ocher 1	LB I
15	x 3443	Jug	See Pl. 41:11	LB I
16	x 3368	Jug	See Pl. 41:13	LB I
17	x 3424	Jug	Large light grits, permanent brown 3, indian red 3 decoration	LB I
18	x 3367	Jug	See Pl. 41:2	LB I
19	x 3389	Jug	Same as No. 2	LB I
	x 3384-88 x 3390-94 x 3422 x 03385-86 x 03388	Jugs	Same type as No. 19	LB I
20	x 3408	Cooking bowl	Many light grits, burnt umber 3	LB I
	x 3407	Cooking bowl	Same type as No. 20	LB I
21	x 3410	Bowl	Charcoal gray 3 core, brown ocher 3 surface	LB I
	x 3411-13	Bowls	Same type as No. 21	LB I
22	x 3439	Jug	See Pl. 41:12	LB I
23	x 3426	Jug	See Pl. 41:9	LB I
24	x 3436	Jug	Permanent brown 3, indian red 3 decoration	LB I
25	x 634	Figurine	Pottery, permanent brown 3, cast in single mold, back finger-modeled; female, bracelets on both wrists	LB I
26	x 3482	Jug	Charcoal gray 1 core, burnt umber 1 surface	LI?
27	x 3440	Jug	Large light grits, charcoal gray 1 core, burnt umber 2 surface	LI?
28	x 583	Wedge	Iron	LI?

TOMB 37 M

TOMB 37 N



1

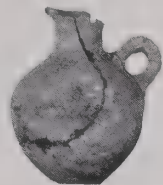

2



3



4

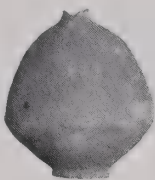

5



6



7



8

TOMB 38

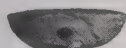

9



10

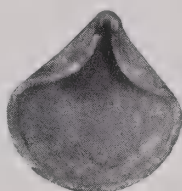

11

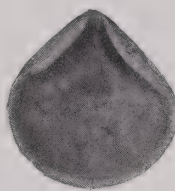

12



18



19



13

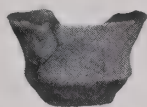

14



15



16



17

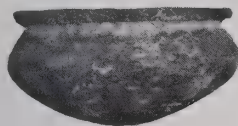

20

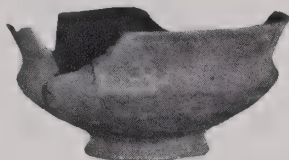

21



22



23



24



25



26

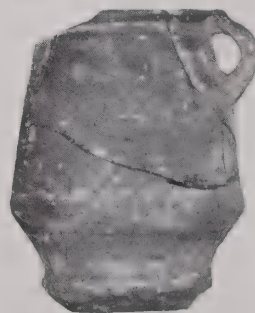

27



28

No.	Field No.	Designation	Description
TOMB 38 B			
1	7003	Bowl	Brown ocher 3
	7012-25 02794 b x 3461-66 x 3478	Bowls	Same type as No. 1; LB I
2	7004	Bowl	Brown ocher 3
	x 3458	Bowl	Same type as No. 2; LB I
3	7005	Bowl	Brown ocher 3
4	7006	Bowl	Brown ocher 3
	7026	Bowl	Same type as No. 4; LB I
5	x 3455	Bowl	See Pl. 41:18
6	x 3473	Bowl	Many mixed grits, permanent brown 3, traces of 2 indian red 3 concentric circles inside
7	x 3474	Bowl	Many mixed grits, permanent brown 3, indian red 3 circle inside
	x 3475	Bowl	Same type as No. 7 with 3 concentric circles inside; LB I
8	x 3471	Bowl	Many mixed grits, permanent brown 1 core, brown ocher 3 <sub>2</sub> surface
	x 3472	Bowl	Same type as No. 8; LB I
9	x 3469	Cooking bowl	Burnt umber 1
	7027	Cooking bowl	Same type as No. 9; LB I
10	x 3476	Lamp	Burnt umber 3
	2795 } 3477 }	Lamps	Same type as No. 10; LB I
11	x 3467	Jar	See Pl. 41:17
12	7001	Jug	See Pl. 41:14
13	x 3468	Jug	See Pl. 41:15
14	x 7007	Jug	Brown ocher 3, indian red 3 decoration
15	x 7008	Jug	Same as No. 14
16	x 7009	Jug	Same as No. 14
	7028-34	Jugs	Same type as No. 16; LB I
17	7010	Jug	Permanent brown 3, indian red 3 decoration
	7035-41	Jugs	Same type as No. 17; LB I
18	x 3479	Jug	Same as No. 17
	7042-44	Jugs	Same type as No. 18; LB I
19	7011	Jug	Same as No. 17
	7045-46	Jugs	Same type as No. 19; LB I
20	x 3470	Inlay	Fayence, light blue, three holes
	2794	Felucca	Perforated; LB I
TOMB 75			
21	P 180	Jug	See Pl. 41:23
22	P 182	Jug	See Pl. 41:22
23	P 179	Jug	See Pl. 41:21
TOMB 77			
24	P 232	Jug	See Pl. 41:27
25	P 233	Jug	See Pl. 41:28
26	P 234	Jug	See Pl. 41:25
27	P 239	Jug	See Pl. 42:2
28	P 240	Jug	See Pl. 42:3
29	P 237	Jug	See Pl. 42:4
30	P 236	Jug	See Pl. 42:7
31	P 231	Bowl	See Pl. 42:11
32	P 228	Milk bowl	See Pl. 42:14
33	P 235	Jar	See Pl. 41:26
34	M 485	Felucca	Intact, t. .007, some light grits, well fired, charcoal gray 3 core, burnt umber 2 surface
35	M 486	Vessel	Diorite (Fig. 184:6)
36	M 488	Vessel	Intact, Egyptian "alabaster" (Fig. 184:9)
37	M 487	Vessel	T. .055, Egyptian "alabaster" (Fig. 184:8)
		Bowl base	Basalt; LB I

TOMB 38 B



TOMB 75



TOMB 77



TOMB 77



LB I OBJECTS FROM TOMBS 38 B, 75, AND 77 (SEE P. 82). SCALE, 1:5 EXCEPT NO. 20, WHICH IS ACTUAL SIZE

No.	Field No.	Designation	Description	Date
TOMB 78				
1	P 246	Jar	See Pl. 42:18	LB I
2	P 243	Jug	See Pl. 42:17	LB I
3	P 245	Jug	See Pl. 42:15	LB I
4	P 248	Bowl	See Pl. 42:23	MI
TOMB 219				
5	3559	Bowl	See Pl. 42:24	LB I
6	P 296	Bowl	See Pl. 42:25	LB I
7	3558	Bowl	See Pl. 42:26	LB I
8	3556	Bowl	See Pl. 43:1	MI
9	P 297	Jug	See Pl. 42:29	LB II
10	3557	Jar	See Pl. 42:28	Stages I-IV*
11	4309	Jug	See Pl. 42:30	MI
12	P 300	Jug	See Pl. 42:31	Hellenistic
TOMB 855				
13	P 2716	Jug	See Pl. 43:9	LB I
14	P 2746	Jug	See Pl. 43:10	LB I
15	P 2750	Bowl	See Pl. 43:15	LB I
16	P 2743	Bowl	See Pl. 43:16	LB I
17	P 2725	Bowl	See Pl. 43:19	LB I
18	P 2740	Bowl	See Pl. 43:20	LB I
19	P 2749	Bowl	See Pl. 43:22	LB I
20	P 2732	Jug	See Pl. 43:23	LB I
21	P 2718	Jug	See Pl. 43:24	LB I
22	P 2724	Jug	See Pl. 43:28	LB I
23	P 2717	Jug	See Pl. 43:29	LB I
24	P 2721	Jug	See Pl. 43:30	LB I
25	P 2733	Jug	See Pl. 43:32	LB I
26	P 2731	Jug	See Pl. 43:5	LB I
27	P 2719	Bilbil	See Pl. 43:6	LB I
28	P 2737	Lamp	See Pl. 44:6	LB I
29	M 2373	Drill-socket	Intact, limestone, socketed at both ends	LB I
30	M 2369	Bowl	Basalt	LB I
31	M 2371	Jar	Egyptian "alabaster" (Fig. 184:3)	LB I

\* Indicates duration of this type. See SAOC No. 10, pp. 52-58.

TOMB 78



TOMB 219



TOMB 855



OBJECTS FROM TOMBS 78, 219, AND 855 (SEE PP. 85-87). SCALE, POTTERY 1:5; OTHER OBJECTS 2:5

No.	Field No.	Designation	Description
TOMB 855			
1	M 2368	Box	Ivory, probably originally in form of duck with head turned backward (cf. Pl. 104), holes for attachment of neck and cover (see p. 188)
2	M 2370	Pin	"Bronze"
TOMB 856			
3	P 2754	Lamp	See Pl. 44:7
4	P 2713	Jug	See Pl. 44:13
5	M 2374	Spindle?	Bone (see p. 172)
6	M 2372	Flint	T. .010
TOMB 876			
7	P 3364	Jug	See Pl. 44:15
8	M 2532	Flint	Arrowhead, t. .007, double feather flaking on both sides, polished and tanged
9	M 2531	Whorl	Reused potsherd, t. .010, brown ocher 2, traces of light red 2 wash (Fig. 175:5)

TOMB 855

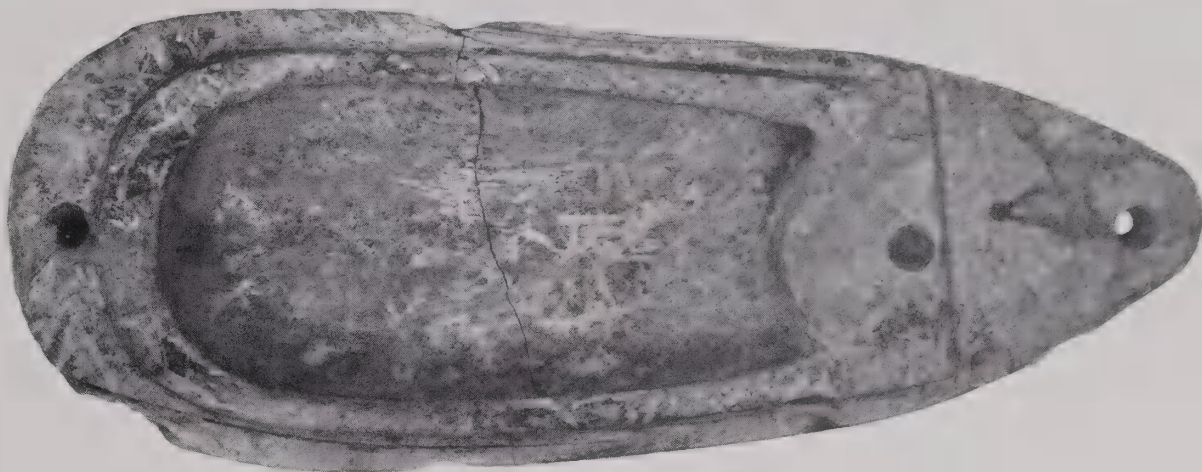
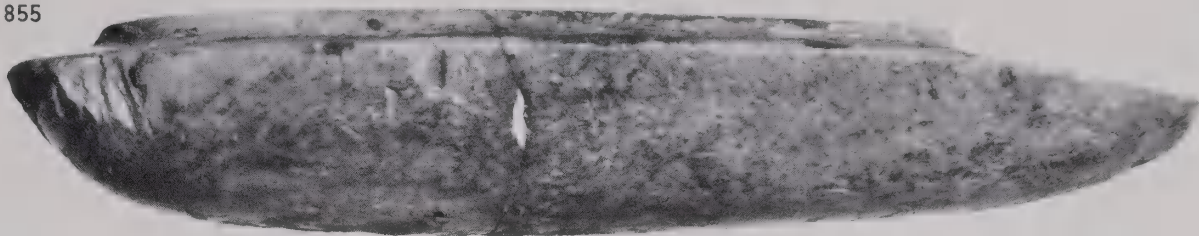

1



2

TOMB 856

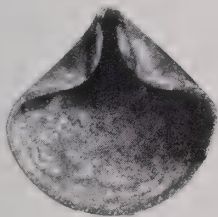

3



4

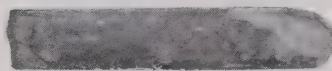

5

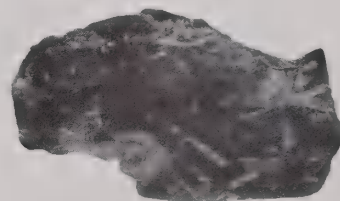

6

TOMB 876



7

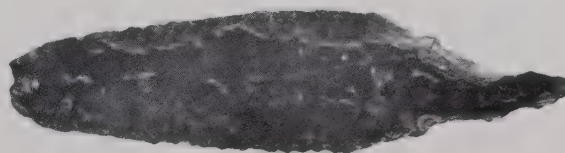

8



9

LB I OBJECTS FROM TOMBS 855-56 AND 876 (SEE P. 87). SCALE, POTTERY VESSELS 1:5; OTHER OBJECTS ACTUAL SIZE

No.	Field No.	Designation	Description
1	P 4413	Bowl	See Pl. 45:6
2	P 4386	Bowl	See Pl. 45:7
3	P 4409	Bowl	See Pl. 45:8
4	P 4384	Bowl	See Pl. 45:9
5	P 4421	Bowl	See Pl. 45:10
6	P 4286	Bowl	See Pl. 45:11
7	P 4285	Bowl	See Pl. 45:12
8	P 4306	Bowl	See Pl. 45:13
9	P 4312	Bowl	See Pl. 45:14
10	P 4399	Jug	See Pl. 45:16
11	P 4395	Jug	See Pl. 45:18
12	P 4282	Jug	See Pl. 45:19
13	P 4381	Jug	See Pl. 45:21
14	P 4275	Jug	See Pl. 45:23
15	P 4400	Jug	See Pl. 45:25 and p. 151
16	P 4278	Jug	See Pl. 45:27 and p. 151
17	P 4403	Jug	See Pl. 45:28 and p. 151
18	P 4273	Jug	See Pl. 45:29 and p. 151
19	P 4294	Jug	See Pl. 45:30 and p. 151
20	P 4299	Jug	See Pl. 45:32 and p. 151
21	P 4292	Jug	See Pl. 45:34 and p. 151
22	P 4295	Jug	See Pl. 46:1
23	P 4296	Jug	See Pl. 46:7
24	P 4300	Jug	See Pl. 46:9
25	P 4323	Jug	See Pl. 46:3
26	P 4383	Jug	See Pl. 46:4
27	P 4377	Jug	See Pl. 46:5
28	P 4417	Jug	See Pl. 46:6



LB I POTTERY FROM TOMB 1100 A (SEE PP. 88 F.). SCALE, 1:5

No.	Field No.	Designation	Description
1	P 4317	Jug	Many light grits, well made, blue-black 3 core, brown ocher 3 surface
2	P 4316	Jug	See Pl. 46:10
3	P 4393	Jug	See Pl. 46:15
4	P 4303	Jug	See Pl. 46:16 and frontispiece
5	P 4318	Jug	See Pl. 46:14
6	P 4281	Jug	See Pl. 46:11
7	P 4394	Jug	See Pl. 46:13
8	P 4412	Jar	See Pl. 47:4
9	P 4287	Lamp	See Pl. 47:1
10	P 4304	Bowl	See Pl. 47:3
11	P 4388	Jar	See Pl. 47:5
12	P 4379	Jar	See Pl. 47:6



0 5 10 15 20 25 CM.

LB I POTTERY FROM TOMB 1100 A (SEE PP. 88 F.). SCALE, 1:5

No.	Field No.	Designation	Description
TOMB 1100 A			
1	M 3522	Beads	.001 long, shell, cylinder disk
2	M 3523	Inlay	T. .002, bone (see p. 186)
3	M 3519	Ring	Intact, "bronze," single wire with overlapping ends (Fig. 176:4)
4	M 3640	Jar	Egyptian "alabaster" (Fig. 184:5)
5	M 3515	Toggle pin	"Bronze," grooved decoration on head
	M 3514 } M 3517 }	Toggle pins	Same as No. 5; LB I
6	M 3516	Needle	Intact, "bronze"
7	M 3520	Chisel	Intact, edge .003 wide, "bronze," end flattened and sharp
8	M 3521	Pin	Intact, "bronze"
9	M 3513	Arrowhead	Intact, t. .004, "bronze," square tang
10	M 3509	Spearhead	"Bronze," socketed (Fig. 170:7)
11	M 3512	Spearhead	"Bronze," socketed
	M 3508	Spearhead	Same as No. 11; limestone core introduced when weapon was thrust into wall of chamber; LB I
	M 3510-11	Spearheads	Same as No. 11; LB I
	M 3641	Loom weight	Pottery; LB I
TOMB 1100 B			
12	P 4435	Bowl	See Pl. 47:7
13	P 4444	Bowl	See Pl. 47:8
14	P 4446	Bowl	Fine ware, few minute light grits, well made, well fired, blue-black 3 core, naples yellow 3 slip, close ring burnishing
15	P 4440	Jug	See Pl. 47:12
16	P 4436	Jar	See Pl. 47:10
17	P 4357	Jug	See Pl. 47:11
18	M 3504	Needle	Intact, "bronze"
19	M 3505	Bead	Fayence, chiefly cobalt green 3, long cylinder with one convex end
20	M 3506	Button	Intact, gold, originally inlaid, small loop of flat gold wire attached to back
21	M 3495	Toggle pin	"Bronze," grooved decoration on head (Fig. 174:7)
	M 3498-3500	Toggle pins	Same as No. 21; LB I
22	M 3503	Bracelet	Silver (Fig. 179:1)

TOMB 1100 A



TOMB 1100 B



LB I OBJECTS FROM TOMB 1100 (SEE PP. 88 F.). SCALE, VESSELS 1:5; OTHER OBJECTS ACTUAL SIZE

No.	Field No.	Designation	Description
1	M 3501	Dagger pommel	T. .030, limestone, socketed, 2 rivet holes for attachment to haft; probably belongs to No. 6
2	M 3502	Dagger pommel	Same as No. 1; probably belongs to No. 5 (Fig. 171:9)
3	M 3492	Spearhead	Bronze (see p. 161 for analysis), socketed, traces of binding-cord and bronze clasp (Fig. 170:8)
4	M 3493	Spearhead	Bronze (see p. 161 for analysis); same as No. 3 (Fig. 170:9)
5	M 3494	Dagger blade	T. .006, bronze (see p. 161 for analysis), 3 rivets for attachment to haft; probably belongs to No. 2 (Fig. 171:9)
6	M 3491	Dagger blade	T. .005, bronze (see p. 161 for analysis); same as No. 5; probably belongs to No. 1 (Fig. 171:10)
7	M 3507	Beads (about 335)	Shell, cylinder disk
	M 3496-97	Pins	"Bronze"; LB I



LB I OBJECTS FROM TOMB 1100 B (SEE PP. 88 F.). SCALE, 4:5 EXCEPT NO. 7, WHICH IS ACTUAL SIZE

No.	Field No.	Designation	Description
1	P 4327	Bilbil	See Pl. 47:13
2	P 4334	Jug	See Pl. 47:15
3	P 4335	Jug	See Pl. 47:14
4	P 4390	Jug	Many mixed grits, permanent brown 3 core, brown ocher 3 surface, traces of spaced vertical burnishing
5	P 4336	Jug	See Pl. 47:17
6	P 4358	Jug	See Pl. 48:3
7	P 4339	Jug	See Pl. 48:6
8	P 4452	Jug	See Pl. 48:4
9	P 4351	Bowl	See Pl. 48:9
10	P 4347	Milk bowl	See Pl. 48:8
11	P 4326	Jar	Brown ocher 2, traces of burnishing
12	M 3490	Beads	(a) Amethyst, circular; (b) fayence, oblate fluted; (c) carnelian, long cylinder; (d) carnelian, long barrel; (e) carnelian, circular fluted; (f) carnelian, long pear shape in imitation of shell; (g) carnelian, long barrel



LB I OBJECTS FROM TOMB 1100 C (SEE PP. 88 F.). SCALE, POTTERY 1:5; BEADS ACTUAL SIZE

No.	Field No.	Designation	Description
TOMB 1100 C			
1	M 3489	Cylinder seal	Intact, serpentine; design includes a man, 2 animals, and a crescent; very worn (see pp. 182-84)
2	M 3488	Scarab	T. .009, steatite, glaze faded to gray, falcons and uraei on <i>nb</i> -baskets (Rowe, <i>Scarabs</i> , No. 339)
3	M 3642	Jar	Egyptian "alabaster" (Fig. 184:7)
4	M 3484	Needle	Intact, "bronze," end bent over to form eye
5	M 3486	Toggle pin	Complete, "bronze," grooved decoration on head
	M 3478-82	Toggle pins	Same as No. 5; LB I
6	M 3483	Pin	Intact but oxidized, "bronze," one end squared to fit into haft
	M 3485	Pin	Same as No. 6; LB I
TOMB 1100 D			
7	P 4460	Bowl	See Pl. 48:11
8	P 4459	Bowl	See Pl. 48:12
9	P 4365	Jug	See Pl. 48:17
10	P 4457	Jug	See Pl. 48:15
11	P 4369	Jug	See Pl. 48:14
12	P 4368	Jug	See Pl. 48:13
13	P 4470	Jug	See Pl. 48:16
14	M 3474	Plaque	T. .001, "bronze"
15	M 3475	Bead	Intact, glass, ultramarine ash blue 3, short barrel
16	M 3472	Toggle pin	"Bronze," grooved decoration on head (Fig. 174:10)
	M 3473	Toggle pin	Same as No. 16; LB I
17	M 3476	Beads	Intact (3 out of 8 illustrated), shell, pierced from both sides, irregular cylinder disk
18	M 3471	Toggle pin	Intact, "bronze" (Fig. 174:11)
19	M 3477	Flint	Arrowhead, t. .008, double flaking on both sides; tang missing

TOMB 1100 C



TOMB 1100 D



No.	Field No.	Designation	Description
1	M 3468	Spearhead	"Bronze," clasp over outside of socket to hold shaft (Fig. 170:6), probably binding-cord beneath clasp
2	M 3458	Dagger pommel	T. .015, marble, fragment of "bronze" attachment fastened by "bronze" rivet (Fig. 171:7); found with No. 6 in hole in wall
3	M 3459	Dagger pommel	T. .016, marble, "bronze" rivet in perforation; found with No. 7 in hole in wall
4	M 3461	Spearhead	"Bronze," no clasp, carbonized binding-cord over socket. A length of cord was laid along the socket, and the cord was then wound around over this length (Fig. 170:5)
	M 3460 M 3462-67 M 3469-70	Spearheads	Same type as No. 4, 2 with remains of both binding-cord and clasp, and a 3d with clasp (intact) extending below end of socket; LB I
5	M 3457	Dagger blade	T. .006, "bronze," 2 rivets for attachment to haft, 2 engraved lines between ribs, chased border outside of ribs
6	M 3456	Dagger blade	Intact, .287 long, t. .007; same as No. 5 (Fig. 171:7); intentionally bent or "killed"; found with No. 2 in hole in wall
7	M 3455	Dagger blade	Intact, .345 long, t. .015; same as No. 5; intentionally bent or "killed"; found with No. 3 in hole in wall
8	M 3454	Dagger	T. .015 at handle, "bronze," traces of bone inlay in handle (Fig. 171:8)



LB I WEAPONS FROM TOMB 1100 D (SEE PP. 88 F.). SCALE, 3:5

No.	Field No.	Designation	Description
TOMB 1141			
1	P 4258	Sherd	See Pl. 49:11
2	P 4257	Platter	See Pl. 49:10
3	P 4268	Cooking bowl	See Pl. 49:3
4	P 4260	Jug	See Pl. 49:5
5	P 4265	Lamp	See Pl. 49:7
6	P 4267	Lamp	See Pl. 49:8
7	P 4266	Lamp	See Pl. 49:9
8	M 3632	Toggle pin	Complete, "bronze," grooved decoration on head (Fig. 174:9)
9	M 3552	Toggle pin	"Bronze," grooved decoration on head
10	M 3629	Flint	T. .007
11	M 3627	Flint	T. .007
Numerous flint flakes not illustrated			
TOMB 1145 A			
12	P 4238	Bowl	See Pl. 49:19
13	P 4237	Bowl	See Pl. 49:16
14	P 4236	Bowl	See Pl. 49:20
15	P 4223	Bowl	Many light grits, blue-black 3 core, burnt um- ber 2 surface
16	P 4219	Bowl	See Pl. 49:22
17	P 4222	Jar-stand	See Pl. 50:1
18	M 3602	Pin	"Bronze"
19	M 3601	Plastron	
20	M 3600	Flint	T. .008, single serrations and polish on upper edge, lower edge blunted
21	M 3599	Flint	T. .009, single serrations and polish on upper edge

TOMB 1141



TOMB 1145 A



LB I OBJECTS FROM TOMBS 1141 AND 1145 A (SEE PP. 94-99). SCALE, POTTERY 1:5; OTHER OBJECTS ACTUAL SIZE

No.	Field No.	Designation	Description
1	P 4185	Lamp	See Pl. 52:6
2	P 4201	Bowl	See Pl. 52:4
3	P 4209	Bowl	See Pl. 50:10
4	P 4199	Bowl	See Pl. 52:3
5	P 4165	Bowl	See Pl. 50:4
6	P 4162	Bowl	See Pl. 50:3
7	P 4205	Bowl	See Pl. 50:5
8	P 4164	Bowl	See Pl. 50:6
9	P 4186	Jug	See Pl. 51:4
10	P 4190	Jug	See Pl. 50:22
11	P 4184	Jug	See Pl. 51:1
12	P 4195	Jug	See Pl. 52:10
13	P 4161	Jug	See Pl. 51:3
14	P 4173	Jug	See Pl. 50:12
15	P 4174	Bilbil	See Pl. 50:13
16	P 4183	Jug	See Pl. 50:14
17	P 4215	Jug	See Pl. 51:2
18	P 4212	Jar	See Pl. 51:8
19	P 4181	Jug	See Pl. 50:16
20	P 4191	Jug	See Pl. 50:21
21	P 4171	Jar	See Pl. 51:7

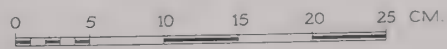

LB I POTTERY FROM TOMB 1145 B (SEE PP. 94-99). SCALE, 1:5

No.	Field No.	Designation	Description
TOMB 1145 B			
1	M 3594	Scaraboid	Steatite, traces of cerulean blue 3 glaze, inscribed with <i>k3</i> -arms between <i>w3d</i> ("flourish") signs over <i>nb</i> -basket (Rowe, <i>Scarabs</i> , No. S. 8A)
2	M 3595	Scarab	Intact, steatite, traces of prussian green 2 glaze, design damaged. Rowe ( <i>Scarabs</i> , No. 256) reads <i>cr</i> .
3	M 3593	Scarab	Intact, steatite, traces of prussian green 3 glaze, purely decorative design (Rowe, <i>Scarabs</i> , No. 413)
4	M 3564	Scarab	Steatite, inscribed with seated sphinx with uraeus before him and behind him the hieroglyphic legend <i>ntr nfr nb t3wy</i> , "Good god, lord of the Two Lands" (Rowe, <i>Scarabs</i> , No. 266)
5	M 3567	Cylinder seal	Intact, fayence, davy's gray 3, traces of cobalt green 3 glaze (see pp. 182 f.)
6	M 3597	Bead	Carnelian, fluted short barrel
7	M 3596	Bead	T. .007, opal (hyalite), ellipsoid lenticular
8	M 3571	Bead	Intact, t. .003, bone, cylinder disk
9	M 3613	Bead	Intact, t. .004, bone, cylinder disk
10	M 3592	Bead	T. .004, bone, cylinder disk
11	M 3573	Pendant	Intact, silver, crescent (see pp. 177 f.; cf. Petrie, <i>Gaza</i> IV 9 and Pl. XX 174)
12-13	M 3616	Toggle pins	"Bronze" (see Fig. 174:8 for drawing of No. 13)
14	M 3598	Inlays	T. .002, bone, perforated, incised decoration (see p. 186)
TOMB 1178			
15	P 4244	Jar	See Pl. 53:2
16	P 4245	Bowl	See Pl. 53:5
17	M 3611	Toggle pin	Complete, "bronze"
18	M 3609	Plaque	T. .001, "bronze," perforated at both ends
19	M 3610	Plaque	Same as No. 18

TOMB 1145 B

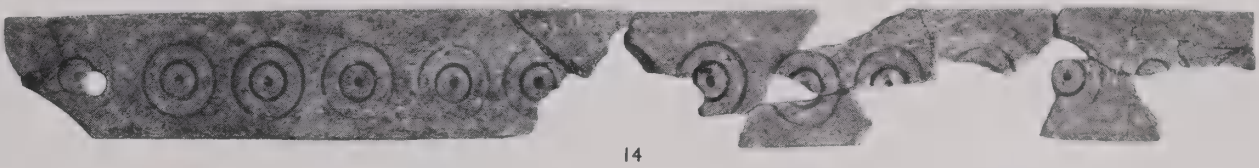
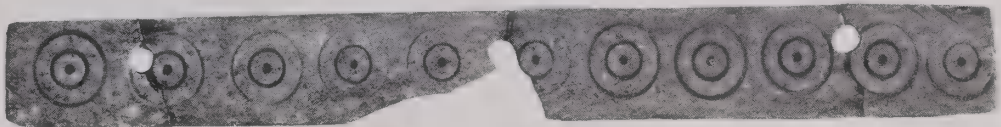
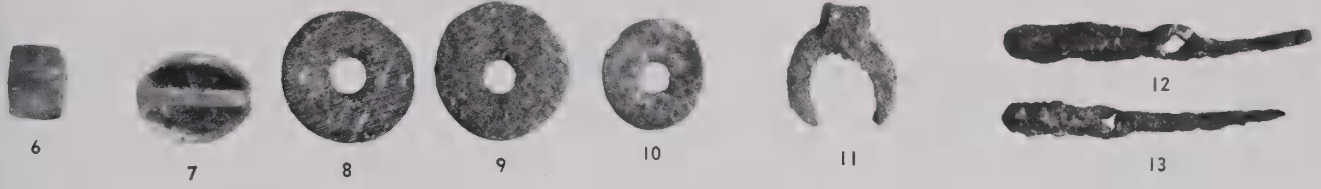

TOMB 1178

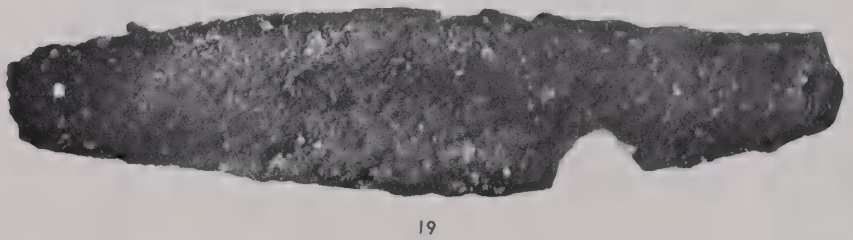
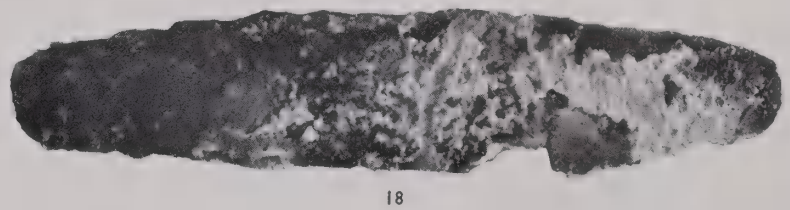

LB I OBJECTS FROM TOMBS 1145 B AND 1178 (SEE PP. 94-100). SCALE, POTTERY 1:5; OTHER OBJECTS ACTUAL SIZE

No.	Field No.	Designation	Description	Scale	Date		
TOMB 1							
1	x 99	Inlay	T. .003, bone	1:1	?		
2	x 105	Arrowhead	Intact but oxidized, "bronze," square tang	1:1	?		
3	x 100	Whorl	T. .027, pottery, poorly fired, charcoal gray 3, standard convex bicone	1:1	?		
4	x 98	Whorl	Intact, bone	1:1	LB II (cf. Fig. 175)		
	x 106	Bowl	Same type as Pl. 62:32		LB II		
	x 1	Milk bowl	Same type as Pl. 56:3		LB II		
	x 29	Milk bowl	Same type as Pl. 64:29		LB II		
	x 2	Bilbil	Same type as No. 15 below		LB II		
	x 107	Jug	Same type as Pl. 12:21		LB II		
	x 104	Lamp	Same type as Pl. 20:6		LB II		
TOMB 2							
5	x 134	Awl	Bone	1:1	LB II		
6	x 25	Bowl	Basalt	1:5	LB II		
7	x 16	Bowl	Basalt, 3 legs	1:5	LB II		
	x 1-2 x 5 x 7 x 13 x 22	Bowls	Same type as Pl. 19:10		LB II		
	x 6 x 8			Bowls		Same type as Pl. 54:5	LB II
	x 9-12			Bowls		Same type as Pl. 64:10	LB II
	x 17-18			Cooking bowls		Same type as Pl. 16:7	LB II
	x 14			Lamp		Same type as Pl. 20:6	LB II
	x 23	Chalice	Same type as Pl. 16:9		LB II		
TOMB 4							
8	x 357	Statuette	"Bronze," Resheph with shield and weapon, lugs for attachment to base (cf. <i>ILN</i> , Nov. 2, 1929, p. 766, Figs. 18-19, for a contemporary example from Minet el-Beida <sup>3</sup> )	1:1	LB II		
9	x 248	Arrowhead	"Bronze," square tang; intentionally bent or "killed"	1:1	LB II		
10	x 243	Drill-socket	Basalt, bored on one side only	1:5	LB II		
11	x 247	Tournette?	Basalt	1:5	LB II		
	x 0247	Tournette?	Same type as No. 11		LB II		
	x 70	Bowl	Same type as No. 6		LB II		
TOMB 8							
12	x 2860	Bowl	See Pl. 56:5	1:5	MB II		
13	x 2859	Milk bowl	See Pl. 56:3	1:5	LB II		
14	x 2862	Flask	See Pl. 56:9	1:5	LB II		
15	x 2861	Bilbil	See Pl. 56:7	1:5	LB II		
16	x 5	Bilbil	See Pl. 56:8	1:5	LB II		

TOMB 1



1

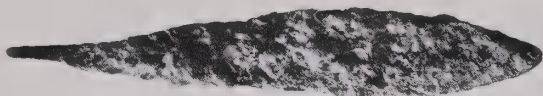

2

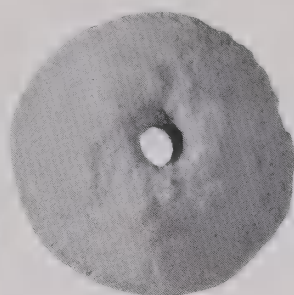

3

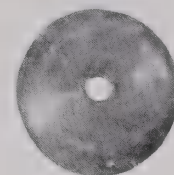

4

TOMB 2

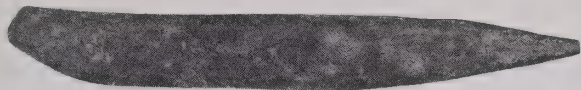

5

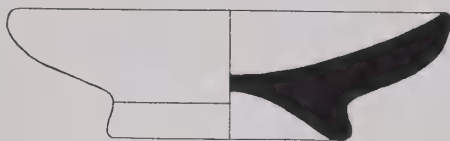

6

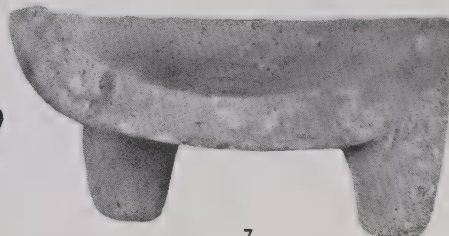

7

TOMB 4



8



9

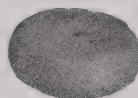

10

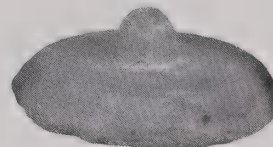

11

TOMB 8



12

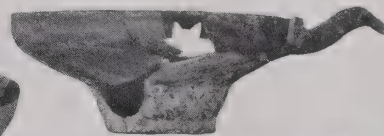

13



14



15



16

No.	Field No.	Designation	Description	Scale	Date
TOMB 13					
1	x 473	Whorl	Intact, slate	1:1	LB II?
2	x 474	Star?	Intact, pottery, perforated; representation of Astarte(?)	1:1	?
	x 42	Bowl	Same type as Pl. 19:14		LB II
	x 44	Milk bowl	Same type as Pl. 19:15		LB II
TOMB 26					
3	454	Flask	Burnt umber 3, indian red 2 spiral decoration	1:5	LB II
	452-53 455-57 x 459-60	Flasks	Same type as No. 3		LB II
4	x 463	Jug	Charcoal gray 3 core, brown ocher 2 surface	1:5	LB II
5	x 3182	Jug	Brown ocher 3	1:5	LB II
6	x 3180	Jar	Burnt umber 2 (see p. 155)	1:5	LB II
7	x 3190	Cooking bowl	Poorly made, charcoal gray 3 core, burnt umber 3 surface	1:5	LB II
8	x 3172	Jug	Brown ocher 3, indian red 3 decoration	1:5	LB I
9	x 3177	Jug	Permanent brown 3	1:5	LB II
	x 3173 x 3175-76	Jugs	Same type as No. 9		LB II
10	x 626	Bowl	Basalt	1:5	LB
11	x 3171	Chalice	See Pl. 57:8	1:5	LB II
12	x 3170	Jar-stand	Large mixed grits, permanent brown 3	1:5	LB II
13	x 604	Socket	Basalt, for tournette(?)	1:5	LB
14	x 9	Bowl	Basalt	1:5	LB
	x 7103	Bowl	Same type as No. 14		LB
15	x 10	Bowl	Basalt	1:5	LB
	x 14-15 x 53-54 x 57	Feluccas			LB
	x 47-48	Rubbers	Basalt and limestone		LB
	x 6-8 x 627	Pestles	Basalt		LB
	x 601 x 603	Grinders	Basalt (Fig. 127)		LB
	x 602 x 620	Grinders	Basalt (cf. Fig. 127)		LB
TOMB 26 A					
16	x 3198	Jar	See Pl. 58:5	1:5	LB II
17	x 3225	Bowl	Poorly made, brown ocher 3	1:5	LB I
18	x 3230	Cup	See Pl. 58:13	1:5	LB I
19	x 3227	Bowl	Charcoal gray 3 core, brown ocher 3 surface	1:5	LB I
20	x 3212	Lamp	Brown ocher 3	1:5	LB I
	x 3213-18	Lamps	Same type as No. 20		LB I
21	x 3205	Jug	Brown ocher 3	1:5	LB I
	x 3204 x 3206-7	Jugs	Same type as No. 21		LB I
22	x 3229	Bowl	See Pl. 58:10	1:5	LB I
23	x 596	Dagger blade	"Bronze"	1:1	LB I? (cf. Fig. 171:10)

TOMB 13

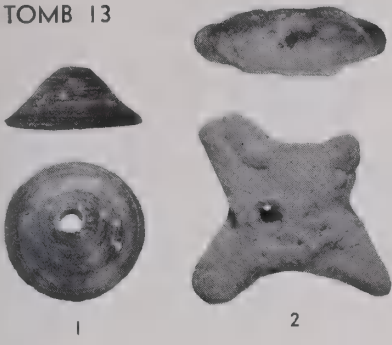

TOMB 26



TOMB 26



TOMB 26 A

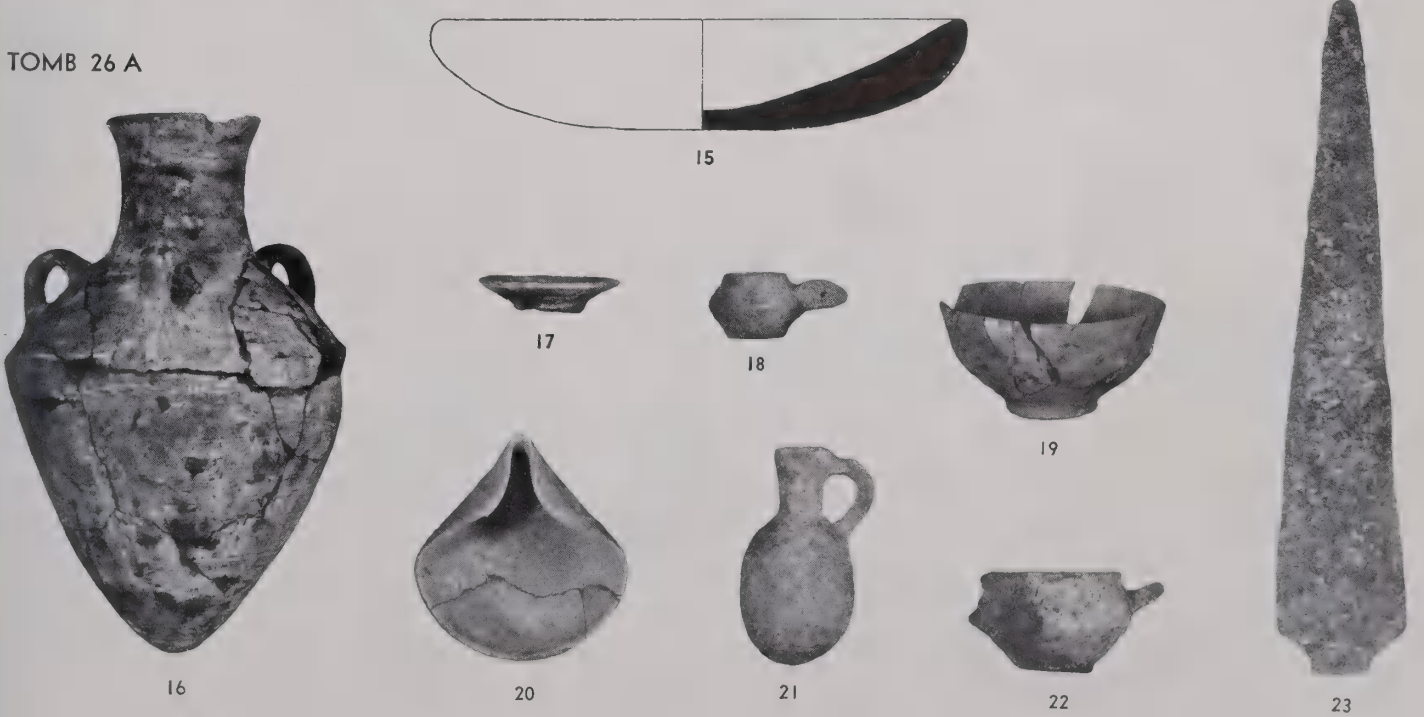

No.	Field No.	Designation	Description	Date
TOMB 26 B				
1	x 3335	Bowl	See Pl. 59:6	LB I
2	x 3291	Bowl	Permanent brown 3, suspension(?) holes below rim; warped	LB I
3	x 3338	Chalice	See Pl. 58:24	LB I
4	x 3263	Lamp	Burnt umber 3	LB I
	x 43 x 3256-62 x 3264-74 x 3337	Lamps	Same type as No. 4	LB I
5	x 3326			
	x 3324 x 3327	Jugs	Same type as No. 5	LB I
6	x 3325	Jug	Permanent brown 3, indian red 2 decoration	LB I
7	x 776	Arrowhead	Intact, t. .004, "bronze," square tang	?
8	x 599	Figurine	T. .025, pottery, permanent brown 3, plaque type; female	?
9	x 598	Figurine	T. .021, pottery, permanent brown 3; female, wearing bracelets	LB (cf. Pls. 99:2 and 139:25)
10	x 600	Pin	Intact, "bronze," depression (not perforation) near right end	?
	x 3334 x 3336	Feluccas		?
TOMB 26 E				
11	x 03345	Bowl	Brown ocher 3	LB I
12	x 3341	Lamp	Brown ocher 3	LB I
	x 3342-45	Lamps	Same type as No. 12	LB I
13	x 3346	Jug	Permanent brown 3, burnt umber 1 decoration	LB I
14	x 623	Awl	Intact, bird bone	?
15	x 624	Needle	Intact, "bronze"	?
	x 3347	Felucca		?

TOMB 26 B



TOMB 26 E

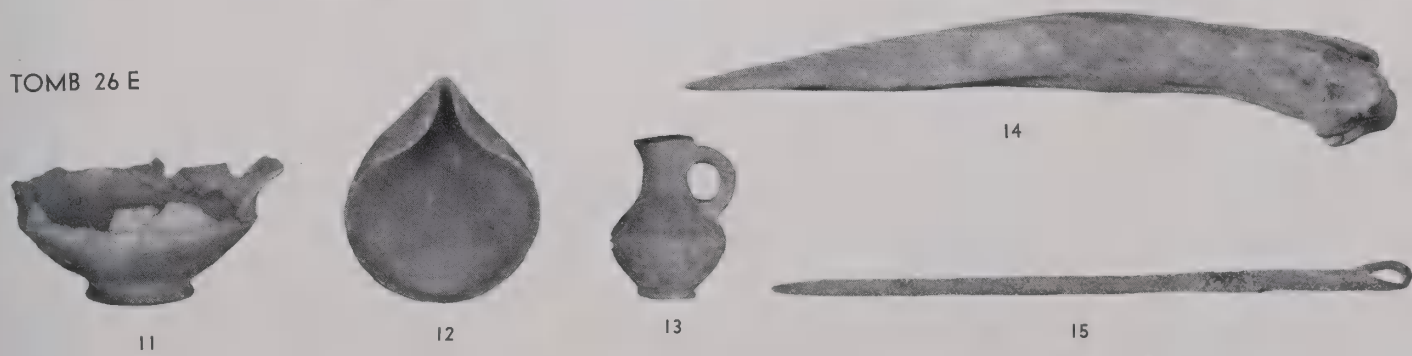

OBJECTS FROM TOMB 26 (SEE P. 103). SCALE, POTTERY VESSELS 1:5; OTHER OBJECTS ACTUAL SIZE

No.	Field No.	Designation	Description	Scale	Date
TOMB 31					
1	x 516	Dagger blade	Intact, t. .004, "bronze," 3 rivets for attachment to haft	1:1	?
		Sherds			Mixed
TOMB 36 A					
2	x 381	?	Pottery, permanent brown 3, traces of indian red 1 wash inside, hole between compartments (at right)	1:5	?
3	x 11	?	Basalt	1:5	?
		Sherds			Mixed
TOMB 36 B					
4	x 525 <i>b</i>	Arrowhead	"Bronze"	1:1	LB
5	x 2	Arrowhead	"Bronze"	1:5	LB
6	x 524 <i>a</i>	Flint	T. .007	1:1	LB
7	x 525 <i>a</i>	Pendant	T. .004, fayence, charcoal gray 3, grape cluster, made in a mold	1:1	LB II? (see pp. 178 f.)
TOMB 40					
8	x 0799 <i>c</i>	Jug	See Pl. 59:15	1:5	LB II
9	{ x 0799 x 0799 <i>a</i>	Chalice Bowl	As found; see Pl. 59:13 and 17	1:5	LB II
10	x 633	Knob?	Glass, blue, perforated after molding	1:1	LB
11	x 631	Nail	Intact but oxidized, "bronze," square head, square in section almost to round point	1:1	LB
12	x 632	Spindle	Bone	1:1	LB II (cf. Fig. 175:6)
13	x 748	Spindle	Bone, originally in 2 pieces, hollow where they meet (opposite No. 5)	1:1	LB II (cf. Fig. 175:6)
14	x 798	Pestle	Basalt	1:5	LB
15	x 797	Rubber	T. .055, basalt	1:5	LB
16	x 0800	Spout	Pottery, permanent yellow 3, eyes perforated	1:5	LB
TOMB 48					
17	x 1352	Funnel	See Pl. 60:3	1:1	LB II
18	x 1353	Funnel	Pottery, large light grits, poorly made, poorly fired, permanent brown 3, hole in base	1:1	LB II
	x 1351	Felucca	Perforated		LB II
	x 1357	Felucca	Reused Cypriote milk bowl sherd		LB II

TOMB 31

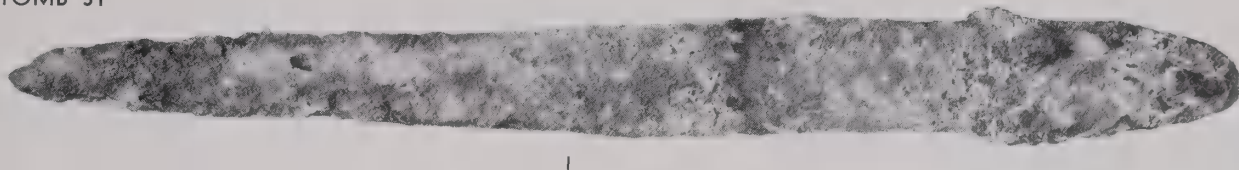

1

TOMB 36 A

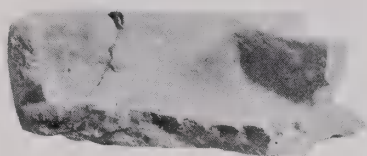

2



3

TOMB 36 B

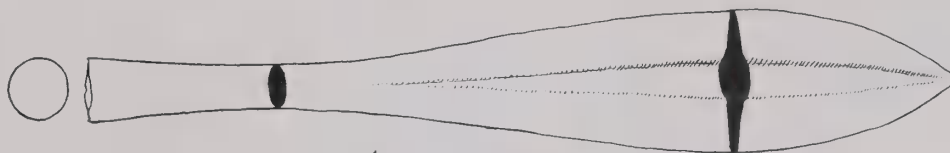

4



5

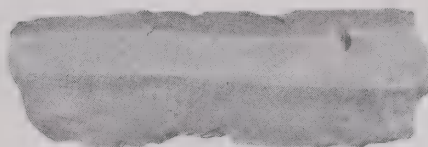

6



7

TOMB 40

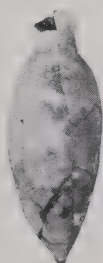

8



9

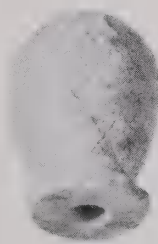

10

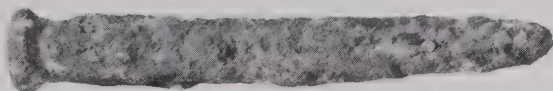

11

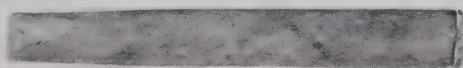

12

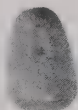

14



15



16

TOMB 48

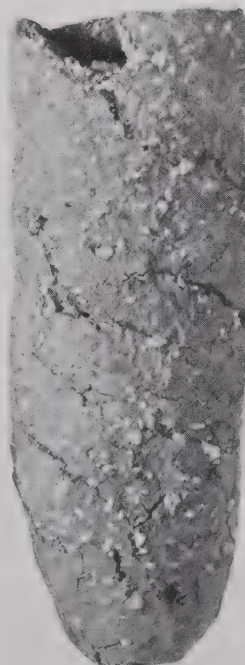

17

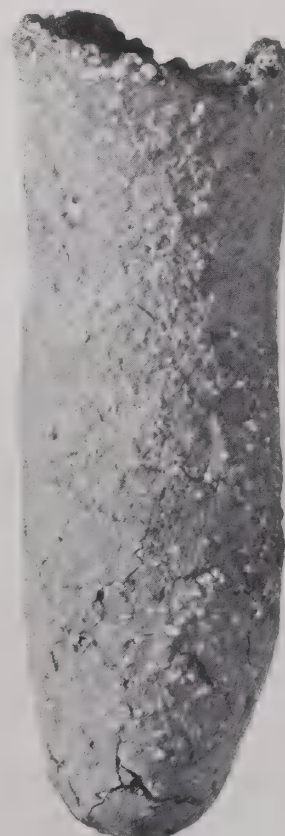

18

13

No.	Field No.	Designation	Description	Scale	Date
TOMB 59					
1	M 13	Amulet	T. .008, carnelian, "bronze" wire loop through perforation; miniature ax with sharp blade (see p. 179)	1:1	?
2	M 14	Hook	"Bronze"; broken at both ends	1:1	?
3	1861	Awl	Complete, bird bone	1:1	?
4	3099 <i>a</i>	Whorl	Intact, limestone	1:1	?
5	3099 <i>b</i>	Whorl	Serpentine	1:1	?
6	3097	Bowl	Basalt	1:5	?
7	3098	Bowl	Basalt, 4 legs	1:5	?
8	2276	Weight	Slightly chipped, gray limestone, 91.7 gr., fair criterion	1:1	?
TOMB 59 A					
9	7100	Bowl	Charcoal gray 3 core, brown ocher 3 surface	1:5	LB I
10	3123	Bowl	Permanent brown 3	1:5	LB I
11	2806	Bowl	Large light grits, charcoal gray 3 core, brown ocher 3 surface	1:5	LB II
12	7101	Bowl	Large light grits, charcoal gray 3 core, burnt umber 3 surface	1:5	LB II
13	2279	Bowl	Poorly made, charcoal gray 3 core, brown ocher 3 surface	1:5	LB II?
14	2810	Jug	Permanent brown 3, indian red 3 wash	1:5	EI II
15	2277	Cooking bowl	Sepia 3 core, brown ocher 3 surface	1:5	LB II
16	7102	Cooking bowl	Large light grits, charcoal gray 1 core, burnt umber 3 surface	1:5	LB II
		Vessels	Pottery		LB II
17	2809	Socket	Basalt, for tournette(?)	1:5	?
18	x 1977	Spindle	Bone	1:1	LB II (cf. Fig. 175:6)
19	1909	Arrowhead	T. .002, "bronze," square tang; slightly bent	1:1	?
20	x 1975	Whorl	Intact, bone	1:1	?
TOMB 59 A-B					
21	1750	Buckle	"Bronze"	1:1	?
22	1749	Beads	Intact; ( <i>a</i> ) fayence, white to light blue, standard cylinder with convex ends; ( <i>b</i> ) carnelian, short barrel	1:1	?

TOMB 59

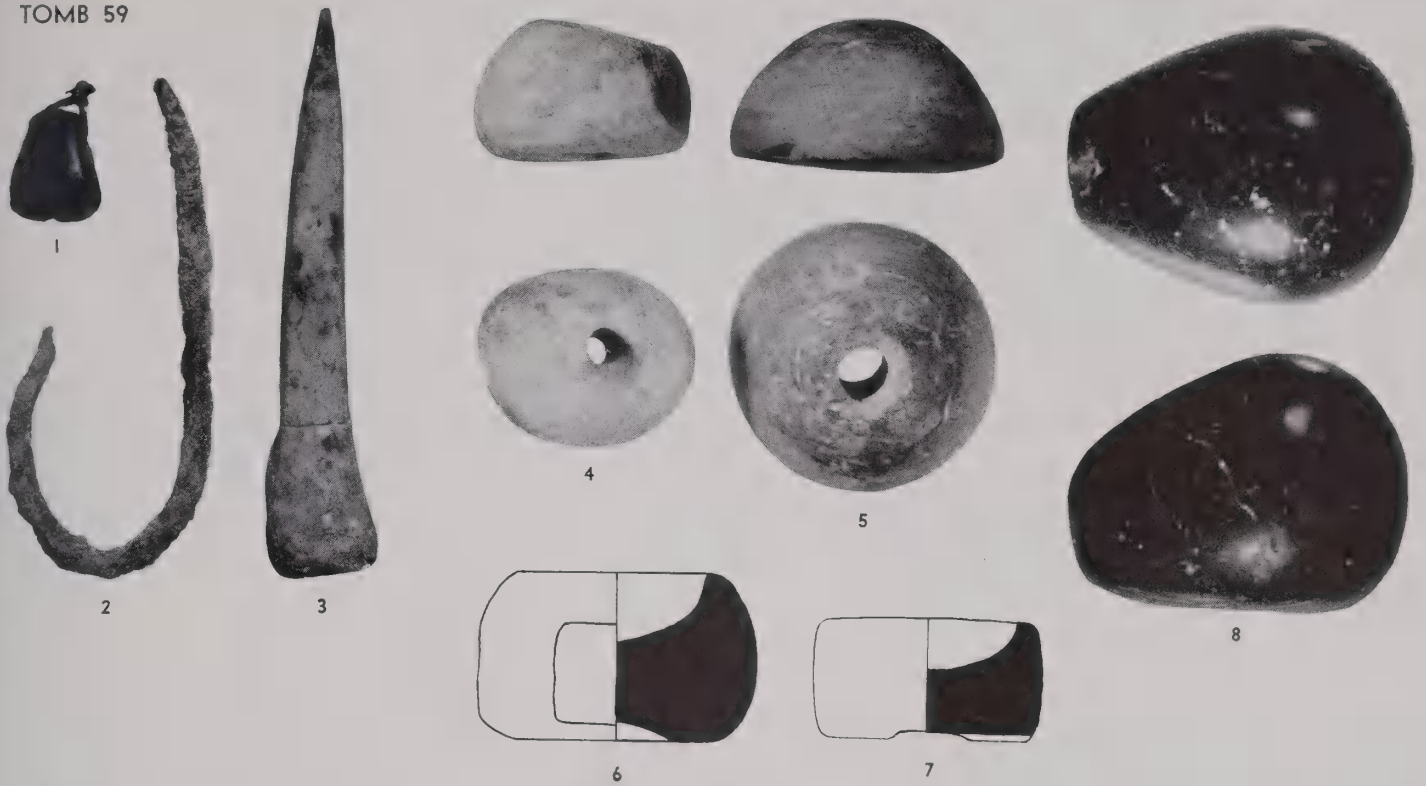

TOMB 59 A



TOMB 59 A-B



No.	Field No.	Designation	Description	Date
TOMB 63 B				
1	5523	Felucca	T. .011, reused potsherd, charcoal gray 3 core and inside surface, Naples yellow 1 outside surface; very worn, edges polished	LB II?
2	3756	?	T. .034, basalt	?
3	3767	?	T. .030, pottery, many mixed grits, heavily fired, Davy's gray 1 core, Naples yellow 1 surface	LB II? (see p. 111)
TOMB 63 C				
4	5525	Felucca	Complete, t. .004, reused milk bowl sherd, fine ware, few mixed grits, light red 3 core, near Davy's gray 3 slip, burnt umber 3 decoration; 3 edges somewhat worn	LB II?
	5524	Felucca	Similar to No. 1	LB II?
TOMB 63 E				
5	P 27	Stirrup cup	See Pl. 62:20	LB II (see p. 111)
6	P 26	Milk bowl	See Pl. 62:9	LB II
7	3826	Spindle	Bone, incised decoration	LB II (cf. Fig. 175:6)
8	M 34	Dagger blade	T. .006, "bronze," tanged	?
9	M 412	Flint	T. .010, upper edge blunted, worn serrations on lower edge	?
10	4081	Dagger blade	T. .008, iron	?
	M 413	Felucca	Similar to No. 1	LB II?
TOMB 63 F				
11	P 62	Jug	See Pl. 63:16	LB II
12	P 68	Jug	See Pl. 63:9	LB II
13	P 41	Jug	See Pl. 63:17	LB II
14	P 44	Flask	See Pl. 63:5	EI I
15	P 67	Bowl	Some large mixed grits, charcoal gray 3 core, burnt umber 3 surface, pottery mark; cracked and patched in antiquity with lime cement to waterproof it	EI I
16	3880	Jug	See Pl. 63:3	?
17	3820	?	See Pl. 63:4	?
18	5526	Felucca	Intact, t. .008, reused potsherd, many mixed grits, burnt umber 3; very worn, edges slightly polished	LB II?
19	M 105	Tournette?	T. .048, limestone (cf. S. Xanthoudides, "Some Minoan potter's-wheel discs" [S. Casson (ed.), <i>Essays in Aegean Archaeology</i> (Oxford, 1927) pp. 111-28])	?
	5527	Felucca	Similar to No. 4	LB II?
TOMB 63 G				
20	3925	Felucca	T. .006, charcoal gray 3 core, burnt umber 3 surface, hole made before firing; very worn, 2 edges polished	LB II?
	3927	Felucca	Similar to No. 20	LB II?
	3926	Felucca	Similar to No. 1	LB II?
TOMB 63 H				
21	M 245	Drill-socket?	Intact, t. .011, gypsum, central hole bored from both sides, 2d hole not completely bored	?
TOMB 63 J				
22	3964	Hammer-rubber	Intact, t. .047, basalt, thumb hole on one side	?
TOMB 63 L				
23	3973	Hammer-rubber	Intact, basalt	?

TOMB 63 B

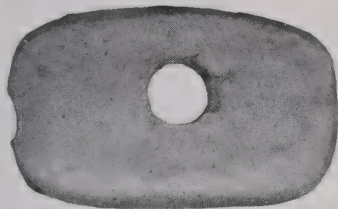

1

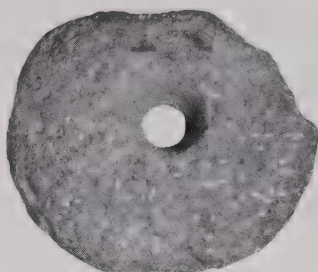

2



3

TOMB 63 C

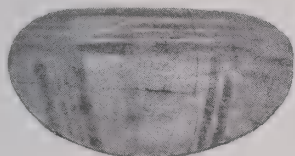

4

TOMB 63 E



5

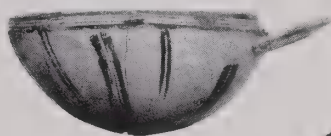

6



7



8



9

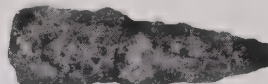

10

TOMB 63 F



11



12



13

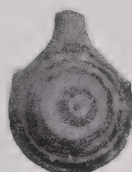

14



15



19



16



17

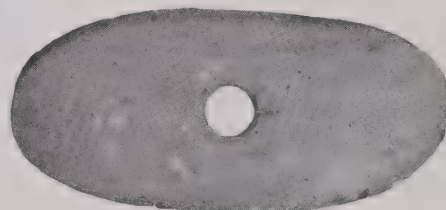

18

TOMB 63 G

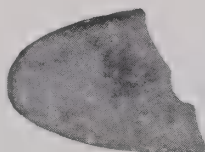

20

TOMB 63 H

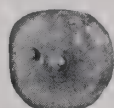

21

TOMB 63 J



22

TOMB 63 L

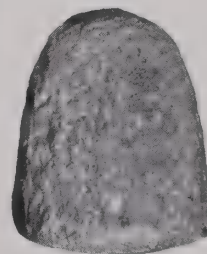

23

No.	Field No.	Designation	Description	Date
1	P 102	Bowl	See Pl. 64:33	EI I
2	3997	Bowl	See Pl. 64:34	EI I
3	P 200	Bowl	See Pl. 64:35	EI I
4	P 76	Bottle	See Pl. 66:18	LB II
5	4154	Jug	See Pl. 66:14	LB II
6	P 85	Jug	See Pl. 66:12	LB II
7	3998	Jug	See Pl. 66:9	LB II
8	P 84	Jug	See Pl. 66:10	LB II
9	4165	Jug	See Pl. 66:13	LB II
10	P 107	Jar-stand	See Pl. 65:21	LB II
11	P 87	Jug	See Pl. 65:28	LB II
12	P 110	Jug	See Pl. 66:2	LB II
13	P 106	Flask	See Pl. 66:19	LB II
14	P 103	Jar	See Pl. 65:19	MI
15	5531	Drain	See Pl. 66:17	M-LI



0 5 10 15 20 25 CM.

LB II AND IRON AGE POTTERY FROM TOMB 73 (SEE PP. 111-13 AND 115). SCALE, 1:5

No.	Field No.	Designation	Description	Date
1	4208	Sherd	Fine ware, few minute mixed grits, well fired, burnt umber 3 core, darker surface, naples yellow 1 decoration, handmade; Cypriote base-ring ware	LB
2	4242	Jug sherd	Charcoal gray 3 core, burnt umber 3 surface, indian red 1 decoration (hourglass)	LB II
3	4257	Jug sherd	Many minute light grits, charcoal gray 3 core, light red 3 to naples yellow 3 surface, india ink 3 and light red 3 decoration (see p. 115)	EI I
4	4259	Bowl(?) sherd	Charcoal gray 3 core, brown ocher 3 surface, light red 1 decoration; perhaps part of No. 9	EI I
5	4253	Jug(?) sherd	Permanent brown 3 core, burnt umber 3 surface, indian red 3 decoration	EI I
6	4248	Jug(?) sherd	Many minute mixed grits, permanent brown 3 core, light red 3 surface, indian red 3 and india ink 3 decoration	EI I
7	4250	Jug sherd	D. .21, many minute mixed grits, permanent brown 3 core, near brown ocher 3 surface, indian red 3 decoration	LB II
8	4264	Bowl sherds	Many minute mixed grits, near burnt umber 3, indian red 3 decoration	LB II
9	4252	Bowl(?) sherd	Same as No. 4 (perhaps part of it)	LB II
10	4247	Jug sherds	Rim d. .12, many large light grits, well fired, charcoal gray 3 core, near naples yellow 1 surface, indian red 1 decoration	LB II
11	P 108	Bowl	Poorly made, burnt umber 3	?
12	4244	Jug sherds	Many large light grits, charcoal gray 3 core, burnt umber 3 surface, indian red 3 decoration; perhaps part of No. 13	LB II
13	4176	Jug sherd	Same as No. 12 (perhaps part of it)	LB II
14	4261	Jar sherd	Rim d. .12, burnt umber 3 core, lighter surface, light red 3 decoration	LB II
15	4178	Jug handle	Fine ware, some minute light grits, well fired, charcoal gray 3 core, brown ocher 1 surface, traces of burnishing, ivory black 3 decoration	LB II
16	4195	Strainer jug	Many mixed grits, burnt umber 3 core, darker surface	EI I
17	5530	Sherd	Coarse ware, many minute mixed grits, well fired, charcoal gray 2 core, brown ocher 3 surface, incised decoration	LB
18	4193	Sherd	Some minute light grits, well fired, charcoal gray 2 core, brown ocher 2 surface, impressed decoration	?
19	4194	Jug(?) sherd	Fine ware, some minute dark grits, naples yellow 1, close horizontal burnishing, indian red 2 decoration	LB II
20	4210	Bowl sherd	Fine ware, few minute mixed grits, well made, naples yellow 1 core, brown ocher 3 outside surface, light red 1 wash inside, close spiral burnishing inside and spaced spiral burnishing outside, light red 3 decoration	E-MI
21	4202	Leg of bowl	See Pl. 65:3	E-MI
22	4046	Bowl sherd	D. .20, some minute mixed grits, well made, naples yellow 1 core, light red 1 wash, spaced horizontal burnishing	E-MI
23	4049	Bowl sherd	D. .16; same as No. 22	E-MI
24	4043	Jug handle	Same as No. 22 except for charcoal gray 3 core	E-MI
25	P 101	Jug	Fine ware, few mixed grits, well made, heavily fired, rubens madder 3 to warm sepia 3 core, warm sepia 3 surface, very close horizontal and vertical burnishing, bister 3 decoration (3 concentric circles opposite handle not visible); Cypriote (cf. <i>OIP</i> XLII, Pl. 5, No. 123)	E-MI



POTTERY FROM TOMB 73 (SEE PP. 111-13 AND 115). SCALE, 2:5

No.	Field No.	Designation	Description
1	4026	Amulet	T. .005, fayence, cerulean blue 3, perforated; seated figure (see p. 179)
2	4032	Amulet	T. .009, fayence, near cobalt green 3, loop for suspension; sow (see p. 179; cf. Petrie, <i>Amulets</i> , Pl. XL 234 a-c [26th dynasty])
3	M 81	Amulet	Complete, t. .006, silver, loop for suspension; animal (see p. 179)
4	M 50	Arrowhead	"Bronze," socketed and ribbed
5	M 68	Gaming-piece?	Intact, ivory
6	M 79	Bead	Glass, intense blue and ultramarine ash blue 3, long truncated concave bicone (cf. Hamilton in <i>QDAP</i> IV, Pl. XXXIV 140)
7	4027	Bead	Glass, india ink 1 and white, long barrel
8	M 84	Beads	Intact, glass, payne's gray 3 to intense blue 3, standard truncated convex bicone; 2 patinated
9	4038	Bead	Glass, davy's gray 3, oblate
10	4025	Beads	Intact, fayence, mineral gray 2, irregular oblate
11	4040	Bead	Intact, fayence, mineral gray 2, short cylinder, collared
12	M 70	Bead	Intact, composition, cobalt blue 3, oblate
13	4042	Bead	Intact but oxidized, "bronze," short barrel
14	4024	Bead	Intact, malachite, circular
15	4041	Bead	Intact, malachite, long cylinder
16	4036	Beads (41)	Intact, material undetermined, naples yellow 2 to brown madder 3, standard cylinder
17	4035	Beads	Intact, material undetermined, purple madder 3, short cylinder with convex ends to standard cylinder with convex ends
18	4037	Beads	Intact, jasper, indian red 2, standard barrel
19	4039	Beads	Intact, carnelian, standard barrel
20	M 82	Bracelet	Intact, "bronze," animal head at either end (see p. 177)
21	4031	Bracelet	"Bronze," animal head(?) at preserved end (cf. No. 20)
22	4030	Bracelet	"Bronze"
23	M 80	Earring	"Bronze"
24	M 94	Bail handle	Iron
25	M 390	?	Intact, pottery, warm sepia 3 to light red 3
26	M 69	Whorl	Pottery, permanent brown 3
27	4010	Hammer	Intact, t. .040, limestone, 2 ends slightly hollowed for grasping
28	M 95	Weight?	Limestone, 28.8 gr., no criterion
29	4034	Shell	Intact, t. .012

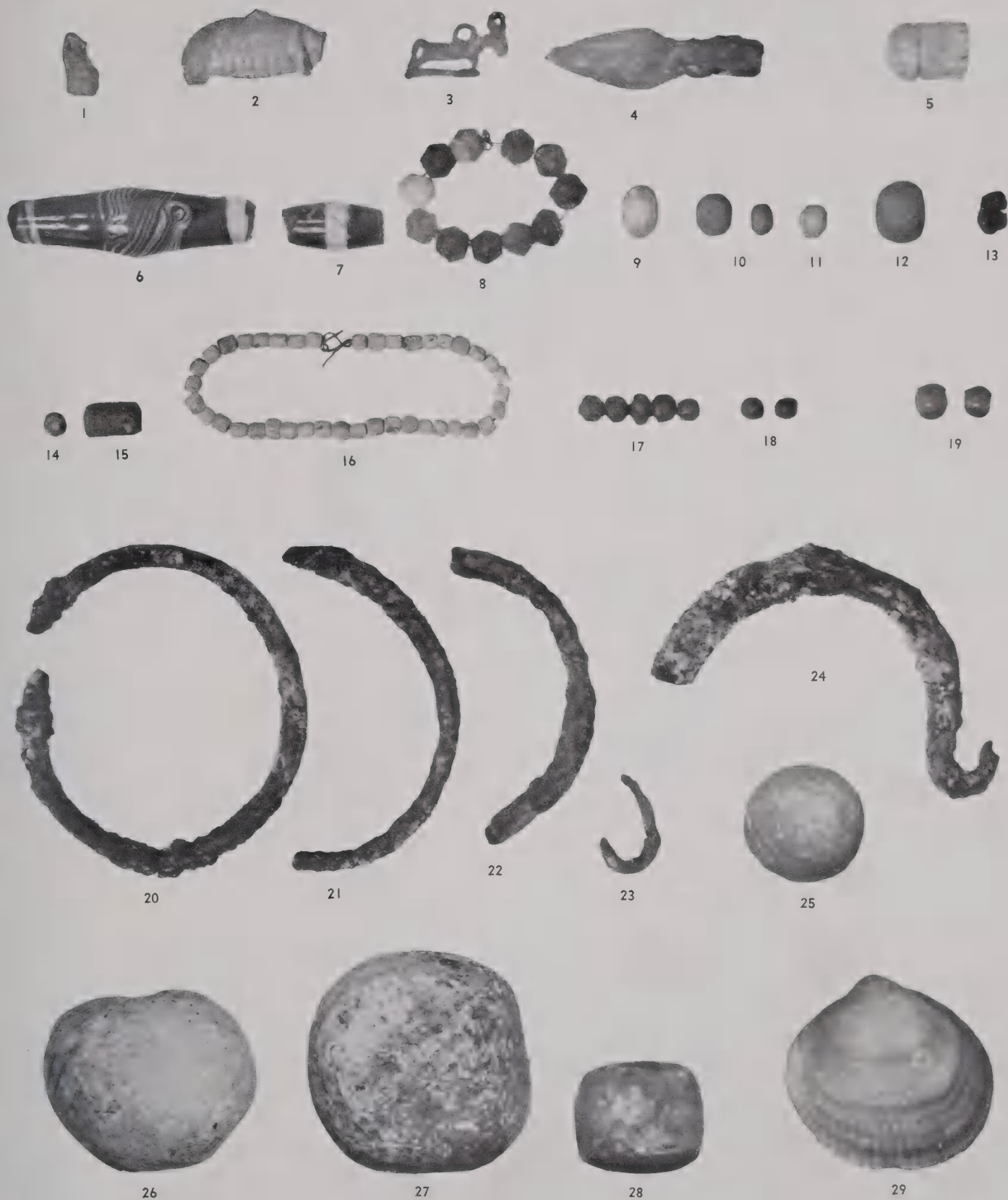

UNDATED OBJECTS FROM TOMB 73 (SEE PP. 111-13 AND 115). ACTUAL SIZE

No.	Field No.	Designation	Description	Scale
1	4054	Flint	T. .011, worn serrations and polish on upper edge	1:1
2	4058	Flint	T. .009	1:1
3	4065	Flint	T. .008, secondary flaking on one end	1:1
4	4070	Flint	T. .006, worn double flaked serrations on upper edge	1:1
5	M 74	Flint	T. .008, upper edge serrated and polished	1:1
6	4077	Flint	T. .008, upper edge serrated	1:1
7	4079	Flint	T. .006, polished	1:1
		Flints (26)		
8	4013	Hammer	T. .065, chert nodule	1:2
	4001-2	Hammers	Limestone nodules	
	4011	Hammer	Chert nodule	
9	M 473	Hammer-rubber	Intact, basalt	1:2
10	4000	Rubber?	Limestone	1:2
11	5528	Bowl	Intact, basalt	1:10
12	4009	Rubber-hammer	T. .060, basalt	1:2
13	3993	Rubber-hammer	Intact, t. .071, basalt	1:2
	4003-4 4012 }	Rubber-hammers	Basalt and limestone	
14	4006	Hammer-rubber	Reused leg of bowl, basalt	1:2
15	4028	Loom weight	T. .067, mud	1:2
16	4008	Hammer	T. .107, basalt, grooved for attachment to handle	1:2
17	4014	Bowl	Basalt, 3 legs	1:2
18	4005	Hammer	Reused leg of bowl, t. .063, basalt	1:2

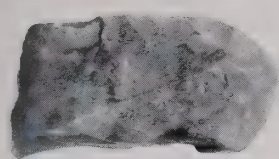

1

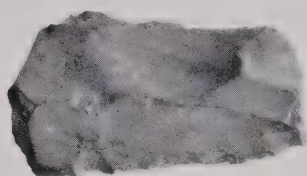

2

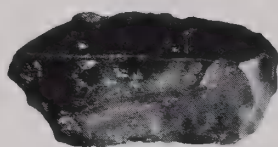

3

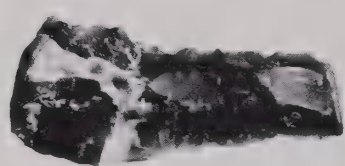

4

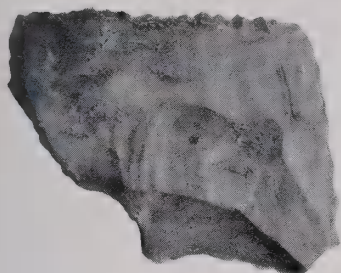

5

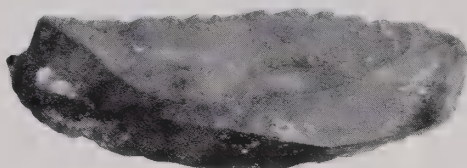

6

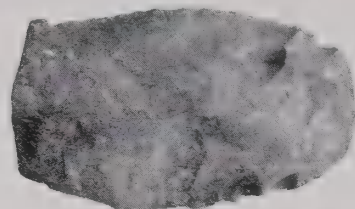

7

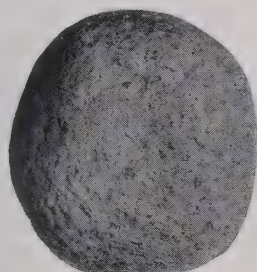

8

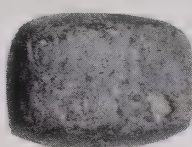

9

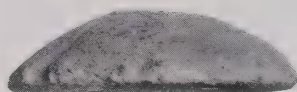

10

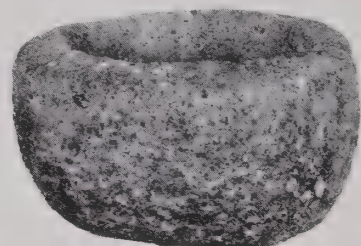

11

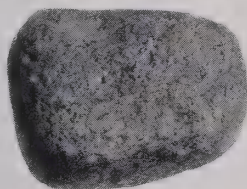

12

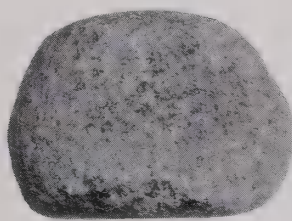

13



14

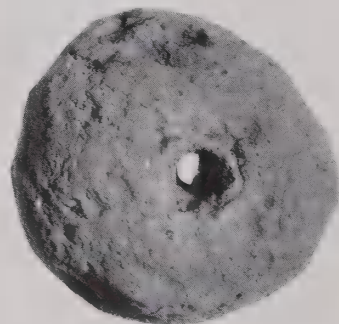

15



16



17



18

No.	Field No.	Designation	Description	Date
TOMB 73				
1	4051	Amulet	Intact, pottery, straw tempering, warm sepia 3, partially blackened by fire; model of human leg, walking charm(?) (cf. Petrie, <i>Amulets</i> , Pl. XXXVII 206 h)	MI? (see p. 179)
2	M 96	Amulet	Same as No. 1	MI? (see p. 179)
3	M 83	Ring	Complete, silver	?
4	M 97	Whorl	Intact, pottery, brown ocher 3	?
5	M 51	Dagger pommel	Limestone, socketed, perforated for attachment	MB II or LB I (cf. Fig. 171:4 and 9)
6	M 73	Palette	Limestone	M-LI (cf. <i>OIP</i> XLII, Pls. 108-11)
TOMB 84 B				
7	M 584	Chisel	"Bronze," one end tapered	?
TOMB 84 C				
8	M 605	Axhead	T. at socket .023, "bronze," pin at one end to fasten haft (Fig. 173:5)	?
9	M 607	Spearhead	"Bronze," socketed, ribbed	MB II or LB I (cf. Fig. 170:3-9)
	M 606	Spearhead	Same type as No. 9	MB II or LB I (cf. Fig. 170:3-9)

TOMB 73



TOMB 84 B

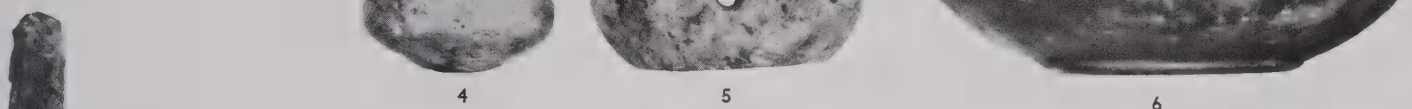

TOMB 84 C

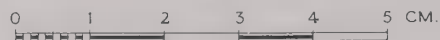
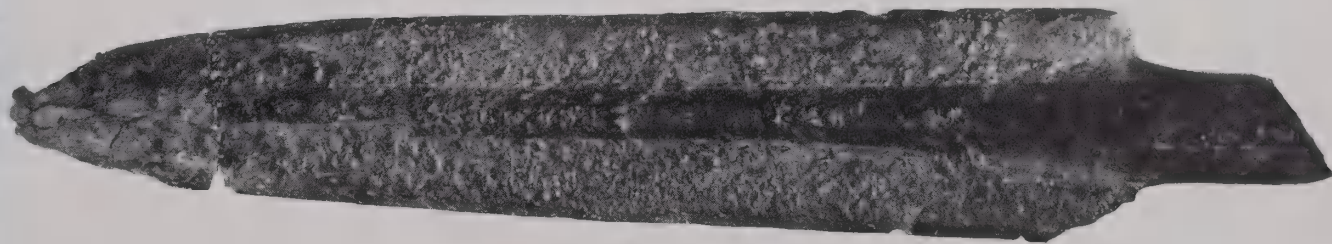
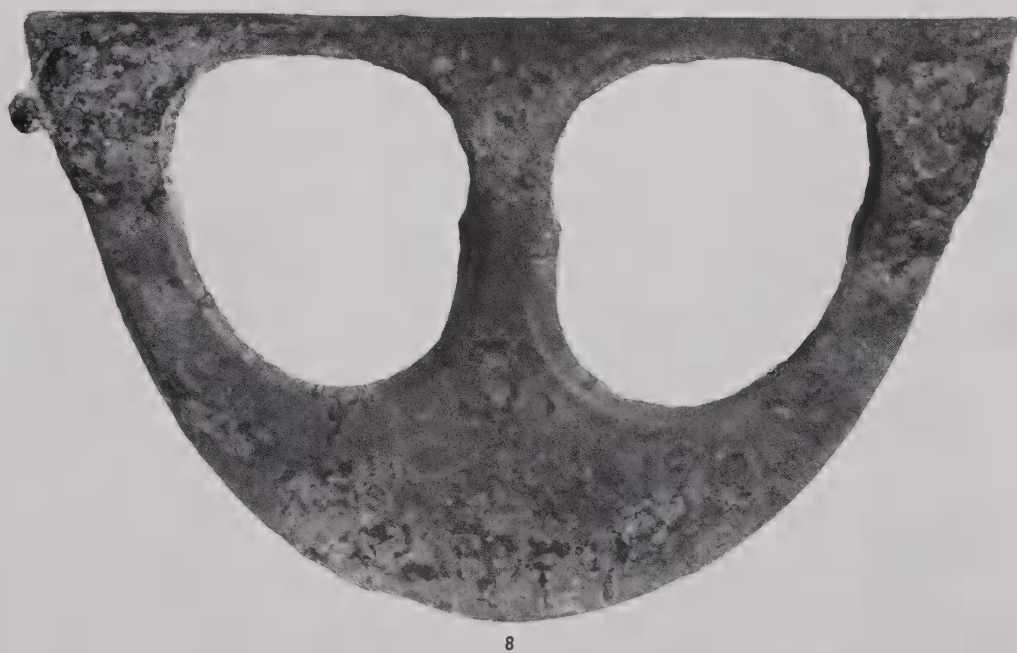

OBJECTS FROM TOMBS 73 AND 84 (SEE PP. 111-13 AND 115). ACTUAL SIZE

No.	Field No	Designation	Description
TOMB 11			
1	x 383	Flask	Permanent brown 3, indian red 3 concentric circles, square handles
2	x 384	Bowl	Dark grits, brown ocher 3
3	x 382	Bowl Sherds	Charcoal gray 3 core, brown ocher 3 surface MB I
TOMB 14			
4	x 420	Whorl	Bone
	x 44	Jar Sherds	Same type as Pl. 18:1; LB II EB, LB II, EI I
TOMB 39			
5	767	Flask	See Pl. 68:10
6	x 735	Flask	Permanent brown 3, indian red 3 spiral around ringed dot
7	756	Bowl	See Pl. 68:16
8	x 705	Bowl	Permanent brown 3 core, naples yellow 2 surface, traces of light red 3 wash, 4 handles
9	x 719	Bowl	Sepia 3 core, burnt umber 3 surface, 4 handles
10	757	Bowl	Burnt umber 2
11	752	Chalice	See Pl. 68:20
12	x 708	Bowl	See Pl. 69:3
13	x 707	Bowl	Permanent brown 3, light red 1 wash
14	x 710	Lamp	See Pl. 68:11
15	x 730	Jar	See Pl. 69:2
16	x 709	Bowl	Poorly made, burnt umber 3 core, permanent brown 3 surface
	758	Bowl	Same type as No. 2; EI I
17	769	Bowl	"Bronze" (Fig. 186:9)
18	x 779	Pestle	Basalt
19	x 622	Pestle	Basalt
20	x 778	Tournette?	Basalt
21	762	Bowl	See Pl. 69:5

TOMB 11

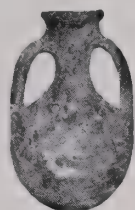

1

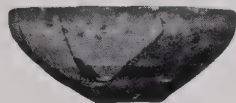

2



3

TOMB 14

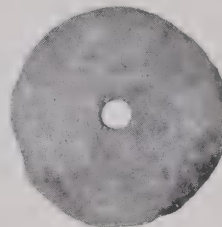

4

TOMB 39



5



6



7

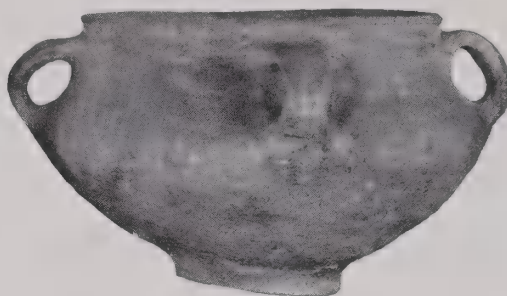

8

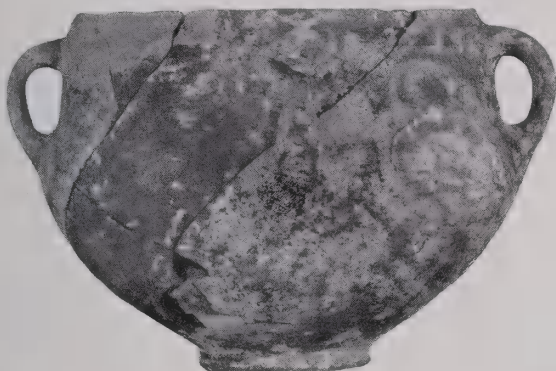

9

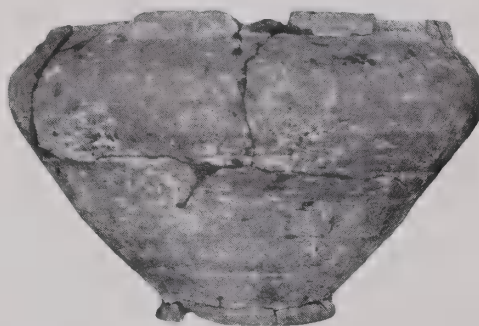

10



11



12

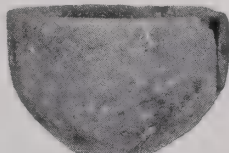

13



14



15



21

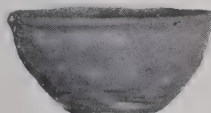

16



18



17



19

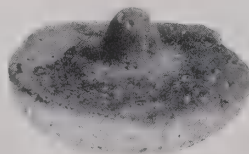

20

EI I OBJECTS (No. 4 EI I or LB II; cf. FIG. 175: S AND 21) FROM TOMBS 11, 14, AND 39 (SEE PP. 116-19)  
SCALE, 1:5 EXCEPT NO. 4, WHICH IS ACTUAL SIZE

No.	Field No.	Designation	Description
1	x 643	Scaraboid	Intact, steatite, obverse inscribed with prenomen of Thutmose III with <i>hpr</i> between feathers(?), reverse inscribed with 3 sun disks over 4 uraei (see p. 185)
2	x 644	Scarab	Fayence, purely decorative design; Hyksos (cf. Pl. 105:6 and Rowe, <i>Scarabs</i> , Nos. 369-70 and 373)
3	x 645	Scarab	Intact, steatite, gold ring with ornamental wire (Fig. 176:15), inscribed with 2 standing figures facing right over a base, with a <i>nb</i> -basket as filler below
4	x 646	Scarab	.008 wide, fayence, gold setting covering base, features of scarab outlined with gold inlay, gold ring with ornamental wire (Fig. 176:16)
5	x 647	Scarab	Steatite, gold setting covering base; back damaged
6	x 673	Scarab	Glass, iridescent, inscribed with Set facing Horus(?) wearing sun disk
7	x 722	Scarab	Intact, steatite, gold setting, gold ring with ornamental wire (Fig. 176:13), inscribed probably with name of Amon-Re (cf. Petrie, <i>Buttons</i> , Pl. XII, esp. No. 675)
8	x 723	Scarab	Fayence, cobalt blue 3, gold setting, gold ring with ornamental wire (Fig. 176:17); base and back damaged
9	x 787	Scarab	Intact, steatite, "bronze" ring with ornamental wire (Fig. 176:14), inscribed with 2 men standing in a boat
10	x 792	Scarab	Intact, steatite, traces of glaze, design like that on obverse of No. 1 (see p. 185)
11	x 793	Scarab	Intact, steatite, back carved to represent an ape, base inscribed with name of Ptah and <i>nb</i> -baskets as fillers
12	x 786	Plaque	Intact, t. .0001, gold foil
13	x 724	Amulet	Intact, t. .009, fayence, white; possibly represents Ptah-Sokar with scarab (Khepri?) on head or Thoth with moon disk (see p. 179)
14	x 654	Amulet	T. .007, fayence, pale blue; Egyptian Bes; legs only preserved (see p. 179)
15	x642 <i>n</i>	Amulet	Intact, fayence, light green; crocodile(?) (see p. 179)
16	x 649	Plaque	Intact, t. .0001, gold foil, scratched decoration
17	x 651	Plaque	Complete, t. .0001, gold foil
18	x 650	Plaque?	T. .0001, gold foil, rosette design
19	x 642	Beads	( <i>a</i> ) Intact, carnelian, short barrel; ( <i>b</i> ) intact, carnelian, long barrel, hole from one face to perforation; ( <i>c</i> ) intact, carnelian, short truncated bicone; ( <i>d</i> ) carnelian, uninscribed scaraboid; ( <i>e</i> ) carnelian, standard barrel; ( <i>f</i> ) carnelian, long truncated bicone; ( <i>g</i> ) intact, glass, white and light blue, ellipsoid with irregular ends; ( <i>h</i> ) intact, fayence, white, short cylinder; ( <i>i</i> ) intact, composition, cobalt blue 3, short cylinder; ( <i>j</i> ) intact, fayence, charcoal gray 3, fluted irregular long barrel lenticular; ( <i>k</i> ) glass, mottled gray, ellipsoid with irregular ends; ( <i>l</i> ) intact, chalcidony, yellow, short truncated bicone; ( <i>m</i> ) intact, fayence, white, oblate



EI I OBJECTS (NO. 2 HYKSOS) FROM TOMB 39 (SEE PP. 117-19). ACTUAL SIZE

No.	Field No.	Designation	Description
1	x 790	Bead?	Sheet gold, short barrel
2	x 788	Ring	T. .005, gold with iron core, iron (greatly oxidized) covered by gold strip with triangular prongs holding an outer gold strip in place, two-strand gold rope welded to each side (Fig. 176:10; see also pp. 162 f.)
3	x 671	Ring	Intact, gold, scratched design in 4 panels (Fig. 176:11)
4	x 791	Ring	Intact, gold; between scratched border lines are 5 panels each containing gouged-out geometric design and separated by approximately vertical ladders (see p. 173)
5	x 777	Ring	Intact but oxidized, "bronze" wire, square in section, ends twisted to form bezel, base flattened (Fig. 176:12)
6	x 672	Earring	Intact, gold (Fig. 178:5)
7	x 648	Earring	Intact, gold (Fig. 178:4)
8	x 794	Medallion	Intact, gold, rim band hammered into center piece; so-called "royal" or "Cappadocian" sign (Fig. 169); intentionally bent or "killed" (see upper view)
9	x 789	Pendants	Gold, hollow; pomegranate (see p. 179)
10	x 674	?	Intact, gold, ends hammered flat
11	x 695	?	Burnt ivory, roughly carved
12	x 677	Shell	
13	x 780	Inlay?	T. .013, ivory, one side incised, convex bicone disk (see p. 186)
14	x 696	Whorl	Intact, serpentine (Fig. 175:22)
15	x 656	Whorl	Intact, serpentine (Fig. 175:23)
16	x 726	Whorl	Bone (Fig. 175:21)
17	x 655	Whorl	Serpentine (Fig. 175:24)
18	x 675	Whorl	T. .005, bone (Fig. 175:20)
19	x 676	Whorl	T. .004, bone (Fig. 175:19)
20	x 796	Inlay	T. .004, bone, corner piece morticed at end for lap joint, peg for attachment (see p. 186)
21	x 641	Inlays	T. .003, bone, 2 decorated, 5 plain (see p. 186)
22	x 717	Comb	T. .006, ivory

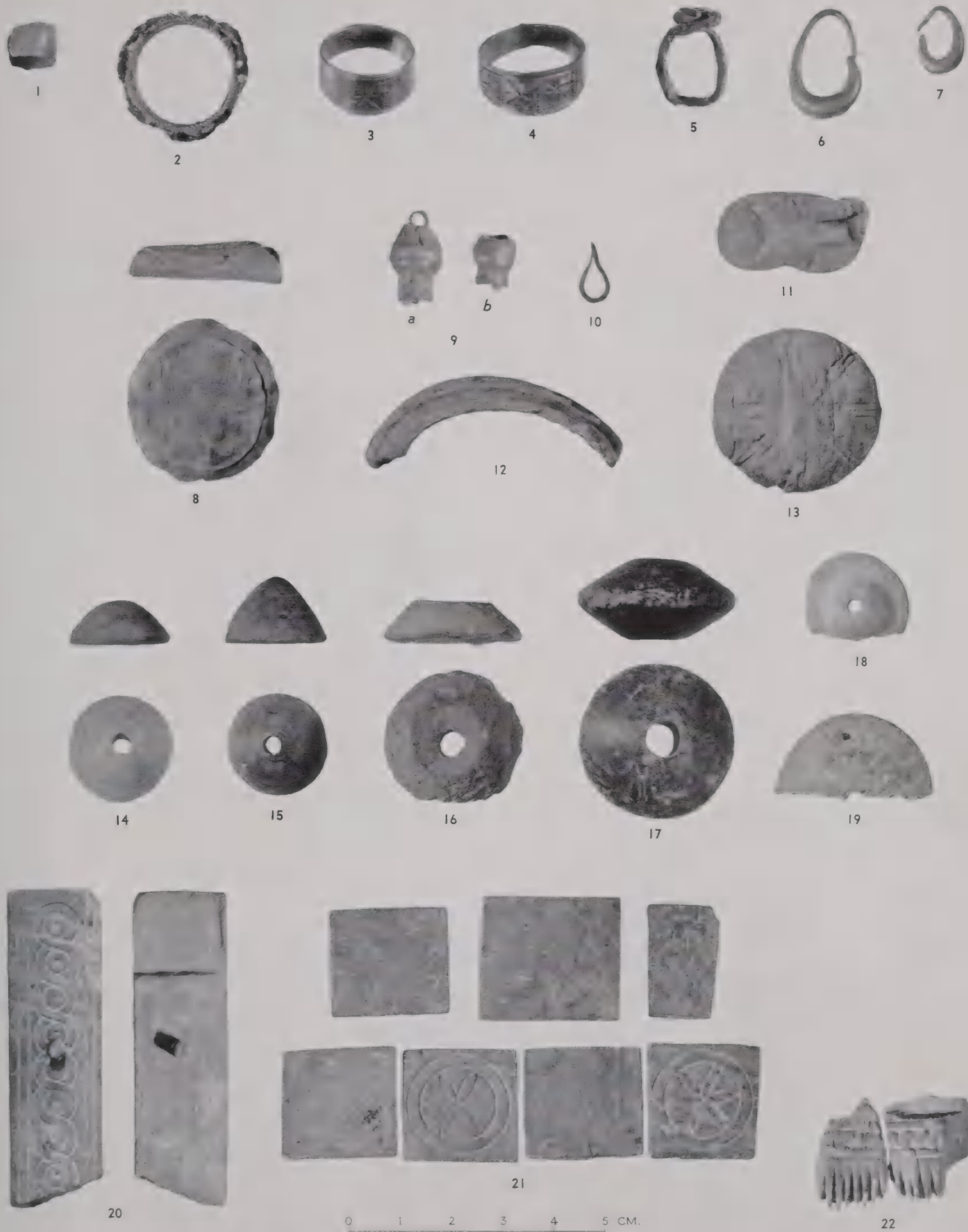

EI I OBJECTS FROM TOMB 39 (SEE PP. 117-19). ACTUAL SIZE

No.	Field No.	Designation	Description
1	x 637	Knife blade	T. .003, "bronze," wood fragments adhering to square tang (Fig. 172:5)
2	x 729	Knife blade	T. .003, "bronze," 2 rivets, upper edge square (Fig. 172:4); both ends broken
3	x 639	Scale-pan?	.005 deep, "bronze"
	x 639 <i>a</i>	Scale-pan?	.150×.115, "bronze," elliptical, rivet for foot or means of suspension; EI I
4	x 727	Earring	Silver (Fig. 178:6)
5	x 782	Nail	Bronze (see p. 161 for analysis); bent
	x 640	Nail	"Bronze"; same type as No. 5; EI I
6	x 701	Knife blade	Badly oxidized, t. .005, iron, traces of sheath consisting of flat back piece and 2 loops (Fig. 172:6; see also pp. 162 f.)
7	x 594	Toggle pin	Complete, "bronze," grooved decoration on head and below eye; Hyksos
8	x 638	Arrowhead	T. .003, bronze (see p. 161 for analysis), round tang
9	x 725	Arrowhead	T. .003, "bronze," square tang
10	x 783	Arrowhead	T. .003, "bronze," round tang

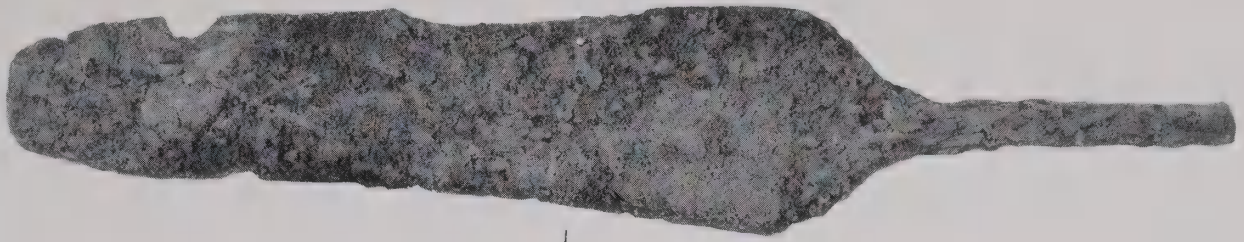

1

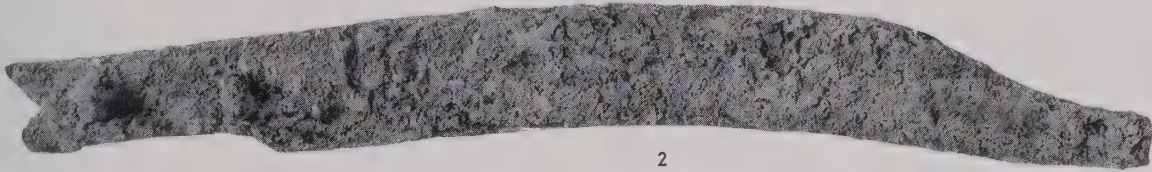

2

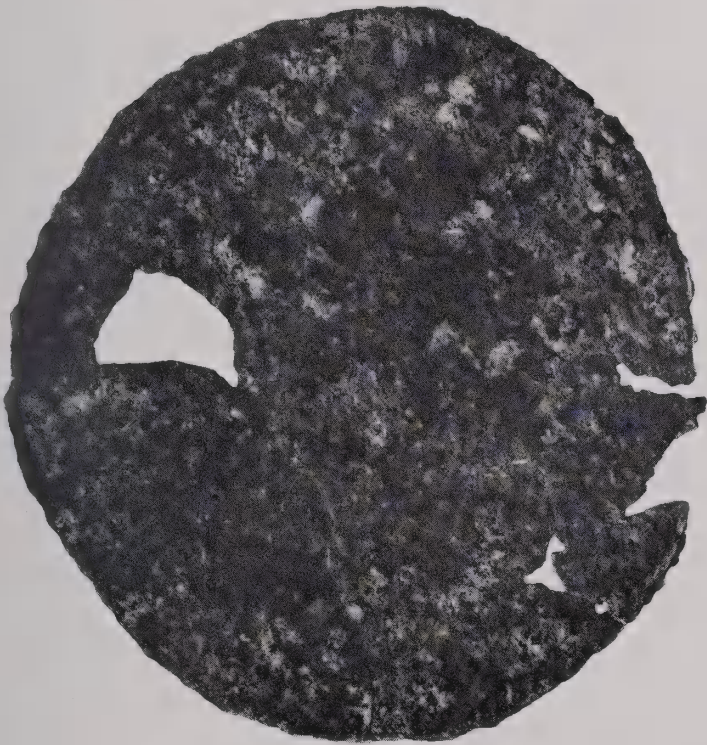

3

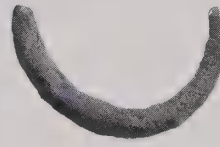

4

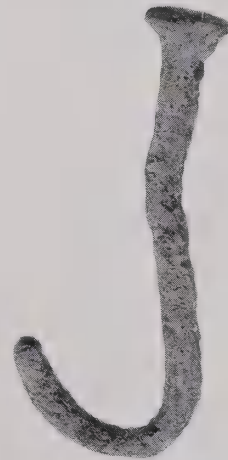

5

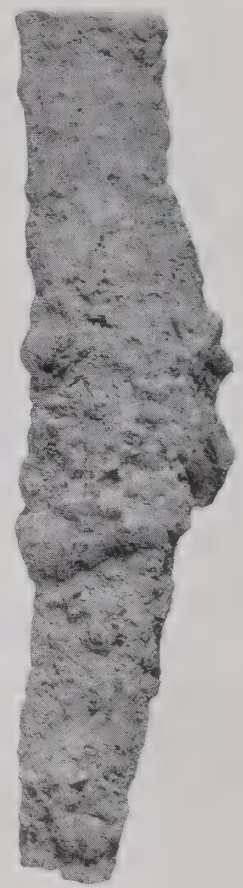

6



7

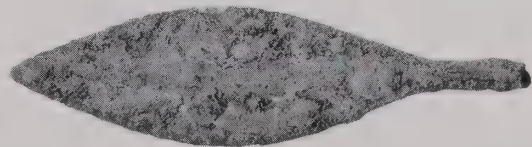

9

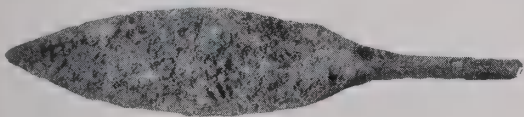

8

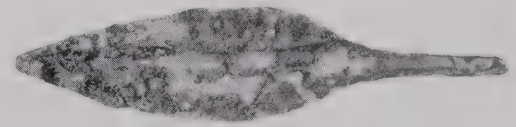

10

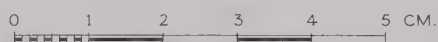

EI I OBJECTS (No. 7 HYKSOS) FROM TOMB 39 (SEE PP. 117-19). ACTUAL SIZE

No.	Field No.	Designation	Description
TOMB 39			
1	x 718	Jar	Fayence, mottled gray (Fig. 185:2); loop handle broken
2	x 700	Weight	Intact, serpentine, bored non-centrally from each end, 36.097 gr., no criterion
3	x 667	Weight	Slate, 3 borings on upper side, right end (tip missing) bored to full width, 2.67 gr., poor criterion
4	x 669	Weight	Oxidized, lead, slight depression on top, 44.143 gr., fair criterion
5	x 688	Weight?	Intact, serpentine, 12.2 gr., good criterion; found in pottery bowl (Pl. 69:5) together with No. 10 and 35 pebbles (weights or slingstones?) of slate, marble, limestone, and serpentine
6	x 659	Weight?	Limestone, worked on all sides, 6.303 gr., good criterion
7	x 704	Weight?	Flint, worked on all sides, 85.61 gr., no criterion
8	x 668	Weight	Hematite, 16 gr., fair criterion
9	x 665	Weight	Hematite, 10.62 gr., fair criterion
10	x 679	Weight	Hematite, 16.512 gr., no criterion; found in pottery bowl (Pl. 69:5) with No. 5 etc.
TOMB 62			
11	M 19	Beads	Chiefly intact; (a) carnelian, long lenticular faceted with some rounded edges; (b) diorite(?), long barrel; (c) carnelian, short truncated convex bicone; (d) carnelian, long barrel; (e) carnelian, long truncated convex bicone; (f) carnelian, short barrel; (g) carnelian, standard cylinder; (h) carnelian, standard barrel; (i) carnelian, oblate
12	M 22	Beads	Intact, gold, short barrel
13	M 17	Spoon?	Ivory, perhaps for ointment (see Madeleine Fr�d�ricq in <i>JEA</i> XIII [1927] 7 ff. and esp. Pl. VIII)
14	M 21	Toggle pin	Intact, gold, socketed, perforated transversely near middle (Fig. 174:13)
15	M 20	Plaque	T. .0001, gold foil
16	M 18	Toggle pin	Silver, socketed, perforated transversely near middle (Fig. 174:12)
17	M 35	Bowl	"Bronze" (Fig. 186:8); found inside of pottery bowl (Pl. 69:9)
	M 36	Gold foil	Small fragment; EI I
		Pin	"Bronze"; EI I

TOMB 39

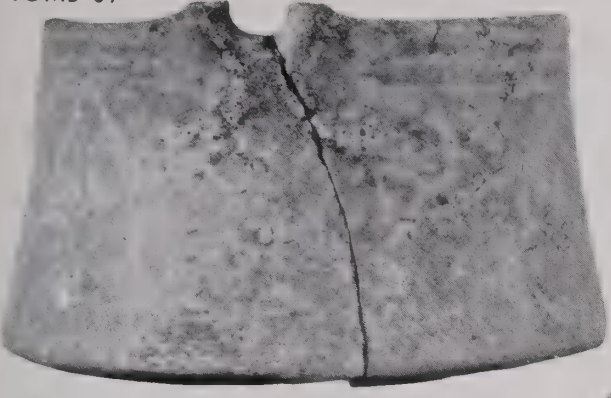

1

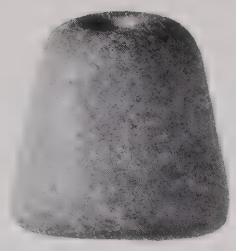

2

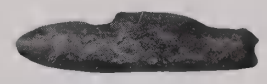

3



4

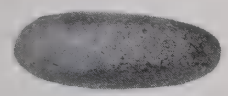
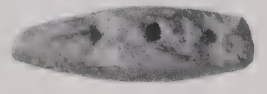

5

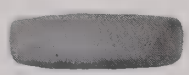

6

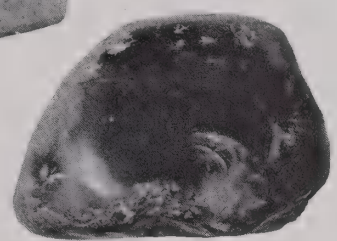

7

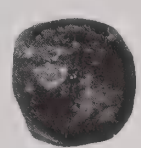

8

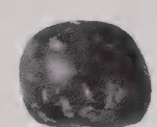

9

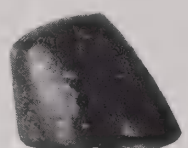

10

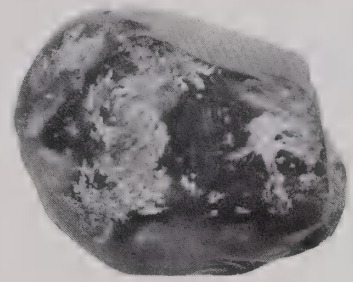

11

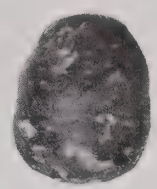

12

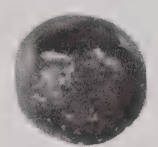

13

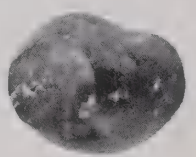

14

TOMB 62

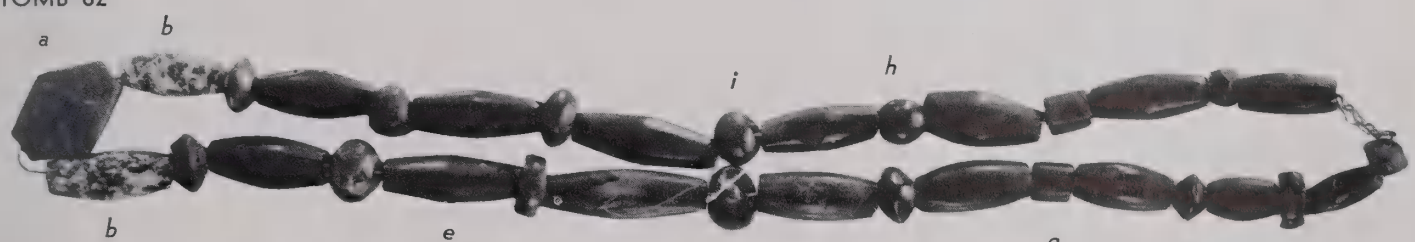

12



13

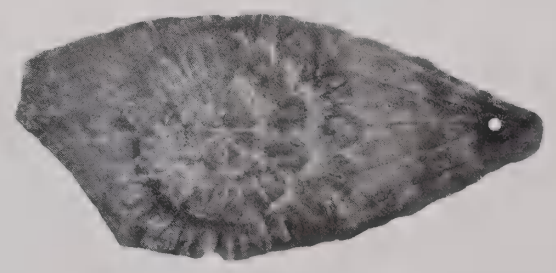

15

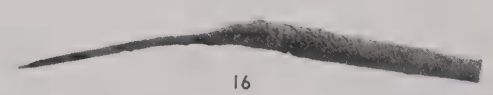

16



14

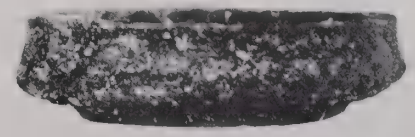

17

EI I OBJECTS FROM TOMBS 39 AND 62 (SEE PP. 117-19). ACTUAL SIZE EXCEPT NO. 17, WHICH IS 2:5

No.	Field No.	Designation	Description
TOMB 71			
1	M 49	Flint	T. .010, bulb on left
2	5532	Flint	Same as No. 3
3	M 47	Flint	Sickle, t. .010, pressure flaking on upper side of upper edge (burnished by use), lower edge sharp, both ends trimmed
4	M 45	Ring	Complete, "bronze" (Fig. 176:9)
TOMB 221 A			
5	P 252	Lamp	See Pl. 70:6
TOMB 221 B			
6	P 321	Bowl	See Pl. 70:11
7	P 339	Bowl	See Pl. 70:9
8	P 328	Bowl	See Pl. 70:10
9	P 324	Bowl	See Pl. 70:13
10	P 323	Bowl	See Pl. 70:14
11	P 349	Bowl	See Pl. 70:15
12	P 332	Bowl	See Pl. 71:2
13	P 351	Jar	See Pl. 72:2
14	P 325	Jar	See Pl. 72:1
15	P 336	Chalice	See Pl. 71:17
16	P 342	Flask	See Pl. 72:4
17	P 341	Flask	See Pl. 72:3

TOMB 71

TOMB 221 A

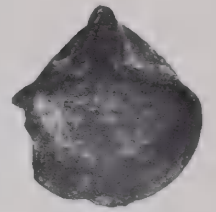
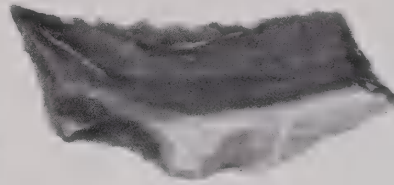
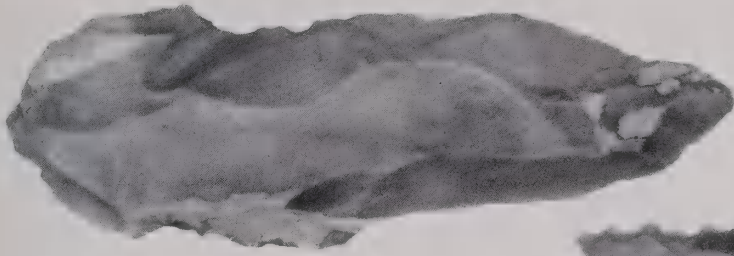

1

2

5

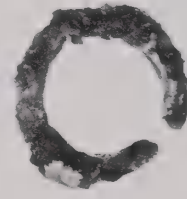
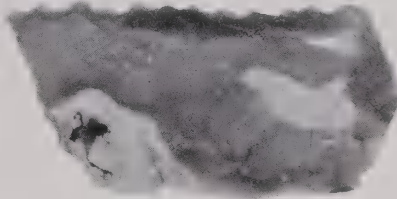

3

4

TOMB 221 B

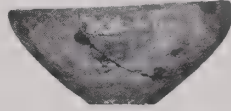
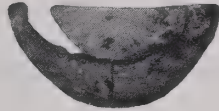
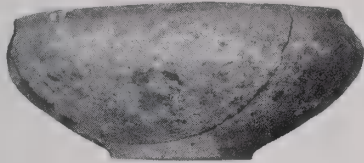

6

7

8

9

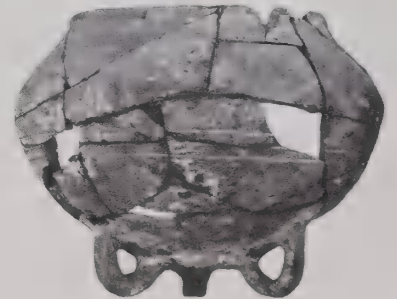
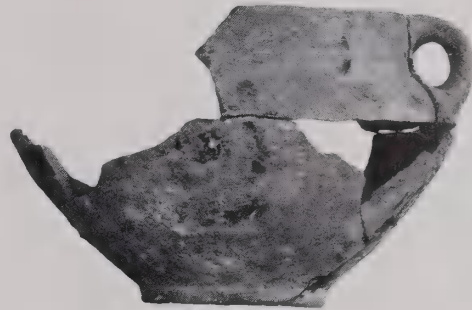
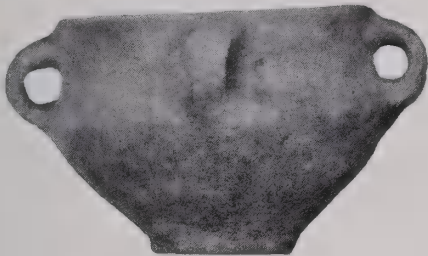

10

11

12

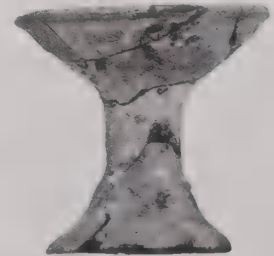

13

14

15



16

17

No.	Field No.	Designation	Description
TOMB 221 B			
1	M 664	Bracelet	Intact, iron (Fig. 179:6; see also p. 162)
2	M 665	Shell	Perforated for use as ornament
3	M 672	Flint	T. .004, worn serrations and polish on upper edge
4	4313	Flint	T. .005, worn serrations on upper edge
TOMB 237			
5	P 371	Bowl	See Pl. 72:11
6	P 372	Jug	See Pl. 72:12
7	P 373	Jar	See Pl. 72:13
8	P 370	Bowl	See Pl. 72:10
TOMB 1090 A			
9	P 3824	Bowl	See Pl. 73:1
10	P 3820	Bowl	See Pl. 73:4
11	P 3822	Bowl	See Pl. 73:3
12	P 3827	Bowl	See Pl. 73:6
13	P 3825	Bowl	See Pl. 73:2
14	P 3826	Jar	See Pl. 73:7
TOMB 1090 C			
15	P 2807	Lamp	See Pl. 73:14
16	P 2805	Bowl	See Pl. 73:12

TOMB 221 B

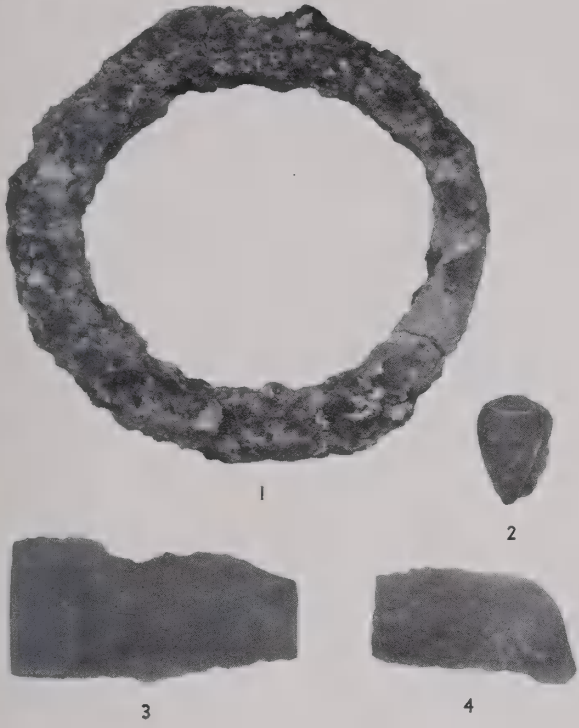

TOMB 237

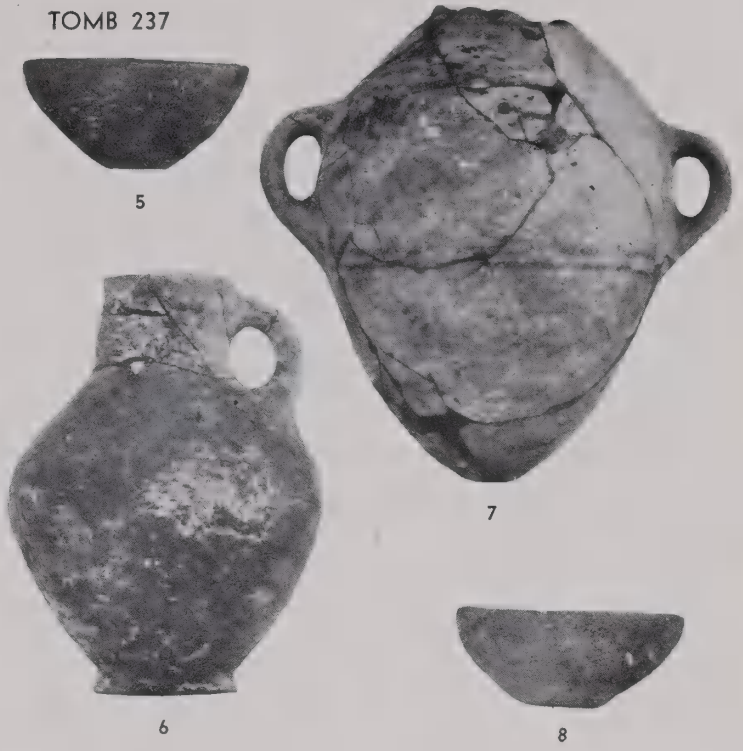

TOMB 1090 A



TOMB 1090 C

No.	Field No.	Designation	Description	Scale	Date
TOMB 27					
1	x 464	Whorl	Intact, slate, perforation filled with lime (Fig. 175:25)	1:1	EI II
2	x 465	Whorl	Intact, bone (Fig. 175:26)	1:1	EI II
TOMB 64					
3	M 25	Pin	"Bronze"	1:1	EI II?
4	3991	Figurine	T. .043, pottery, few minute mixed grits, poorly made, charcoal gray 2 core, light red 3 wash, traces of burnishing; female	1:1	EI II (see p. 127)
5	M 24	Bead?	T. .006, shell, back removed	1:1	EI II?
6	M 23	Flint	Sickle, t. .008, pressure flaking on upper side of upper edge (slightly burnished by use), lower edge sharp, both ends trimmed	1:1	EI II?
TOMB 5					
7	x 2856	Lamp	Brown ocher 3	1:5	MI
8	x 2857	Jug	Few grits, well fired, burnt umber 3	1:5	Roman
9	3157*	Coin	"Bronze," Elagabalus (A.D. 218-22), 4th Neocoria. <i>Obv.</i> : [AY]TK.M.AY <sup>1</sup> P.[ANT]Ω[NE]INOC. Laureate bust of Elagabalus to r. wearing cuirass and paludamentum. Countermark. <i>Rev.</i> : ΠΡΩ[ΤΩΝ ΑC]IAC]ΕΦΕ <sup>1</sup> C <sup>1</sup> [I]Ω[N] Exergue: Artemis seizing fallen stag by the horns. (Cf. British Museum, <i>Catalogue of the Greek Coins of Ionia</i> , by B. V. Head [London, 1892] pp. 90-91.)	9:8	A.D. 218-22
10	3156**	Coin	Silver dirhem of Ahmad ibn Tūlūn (254-70/868-83), struck at Damascus in 267-69/880-82. (Cf. Stanley Lane-Poole, <i>The Coins of the Mohammadan Dynasties</i> ["Catalogue of Oriental Coins in the British Museum" II (London, 1876)] pp. 64-65.)	9:8	A.D. 880-82
			<i>Obv. area:</i>		
			لا اله الا الله وحده لا شريك له المفوض الى الله		
			<i>Inner margin:</i> بسم الله ضرب هذا الدرهم بدمشق سنة سبع (؟) تسع وستين [ومايتين]		
			<i>Outer margin:</i> [الله الامر من قبل ومن بعد] ويومئذ يفرح المومنون [بنصر الله]		
			<i>Rev. area:</i>		
			الله مكمد رسول الله المعتمد على الله احمد بن طولون		
			<i>Margin:</i> مكمد رسول الله ارسله بالهدى [ودين الحق ليظهره على الدين كله ولو كره المشركون]		
11	3159	Bead	Intact, carnelian, short barrel	1:1	?
12	3158	Bead	Carnelian, oblate	1:1	?
13	3160	Bead	Intact, composition, blue, long fluted	1:1	?
14	3161	Bracelet?	D. inside .07, drawn glass, cobalt green 3 and ultramarine ash gray 3, convex conoid in section (see p. 177)	1:1	Roman
		Sherds			MI
TOMB 47					
15	1759	Saucer	Permanent brown 3	1:1	?
16	1761	Saucer	Burnt umber 3	1:1	?
17	1013	Bead	Intact, fayence, light blue, standard barrel	1:1	?
18	996	Amulet	Fayence, cobalt green 3; standing ape (cf. Petrie, <i>Amulets</i> , Pl. XXXVII 204 b) or "Nehebkaui" (see p. 179; cf. Petrie, Brunton, and Murray, <i>Lahun</i> II, Pl. L, top row, 4th and 9th from left)	1:1	?
19	1012	Bead	Intact, carnelian, long pear shape	1:1	?
20	15	Jar	Permanent brown 1 core, brown ocher 3 surface	1:5	MI

\* Described by Dr. N. C. Debevoise of the Oriental Institute.

\*\* Described by Dr. Nabia Abbott of the Oriental Institute.

TOMB 27

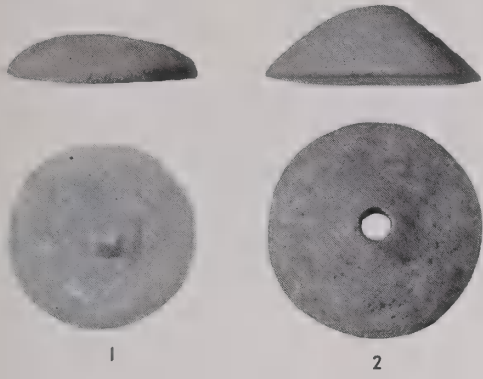

TOMB 5

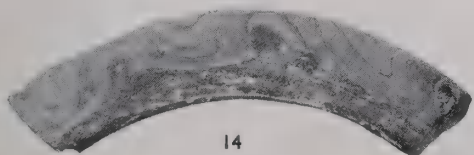
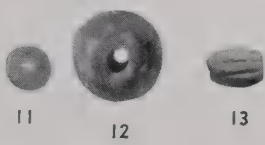
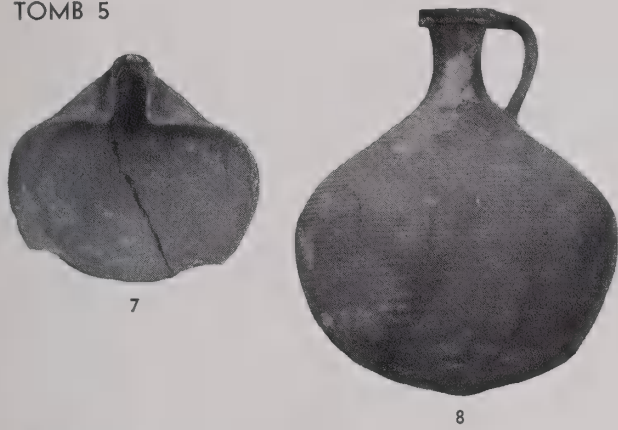

TOMB 64

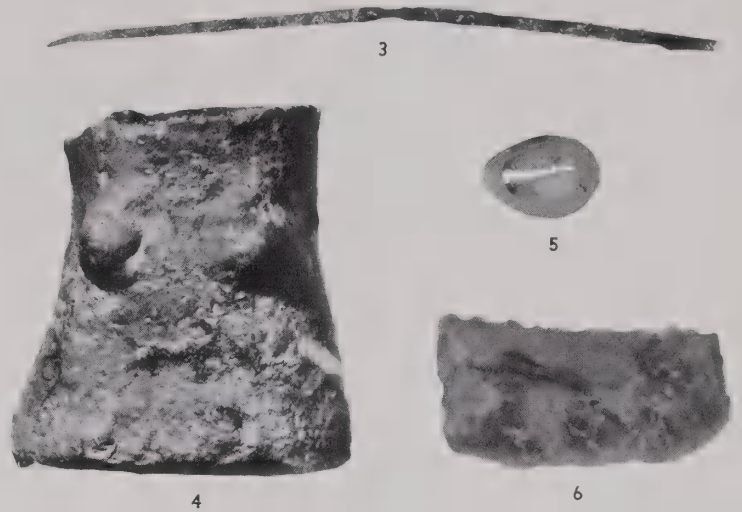

TOMB 47



No.	Field No.	Designation	Description	Scale	Date
TOMB 47					
1	995	Inlay	T. .004, ivory, convex, 4 pegs still in place, oblique perforation	1:1	MI? (see p. 186)
2	1340	Figurine	T. .027, pottery, charcoal gray 1; animal (cf. <i>OIP</i> XXVI, Pls. XXXV-XXXVII)	1:1	MI?
3	1760	Figurine	T. .026, pottery, brown ocher 3; animal (cf. <i>ibid.</i> )	1:1	MI?
4	994	Jar	Egyptian "alabaster"	1:1	?
TOMB 76 A					
5	3525	Bowl sherd	D. .22, many mixed grits, permanent brown 3 core, burnt umber 3 surface, traces of close horizontal burnishing outside, light red 1 and roman sepia 1 decoration inside and out	1:2	EI
6	3526	Bowl sherd	D. .33, many large mixed grits, chiefly brown ocher 3 core, burnt umber 3 surface, light red 1 decoration	1:2	EI I
7	3521	Jug sherd	Fine ware, some minute mixed grits, near brown ocher 3 core, burnt umber 2 surface	1:2	?
8	3516	Jar handle	Coarse ware, many large mixed grits, vandyke brown 3 core, burnt umber 3 surface, pottery mark	1:2	LB?
9	P 210	Lamp	Intact, .035 high, fine ware, some minute mixed grits, burnt umber 3 surface (cf. <i>OIP</i> XLII, Pl. 37, No. 2)	1:2	LI (Greek)
10	3523	Bowl	Permanent brown 1 core, near naples yellow 1 surface, traces of light red 2 wash outside, light red 1 decoration inside	1:2	MI
11	3520	Jar sherd	Few mixed grits, poorly made, well fired, brown ocher 1 core, burnt umber 2 surface	1:2	Roman
12	P 204	Flask	See Pl. 74:14	1:5	EI I
13	4082	Flask	See Pl. 74:15	1:5	EI I
14	P 209	Lamp	See Pl. 74:23	1:5	E-MI
15	P 227	Chalice	See Pl. 74:25	1:5	EI II
16	P 226	Bowl	See Pl. 74:16	1:5	EI II
17	P 202	Jug	See Pl. 74:18	1:5	EI II
18	P 225	Jug	See Pl. 74:19	1:5	EI II
19	P 203	Jug	See Pl. 74:20	1:5	E-MI
20	P 201	Jug	See Pl. 74:22	1:5	MI?

TOMB 47



1

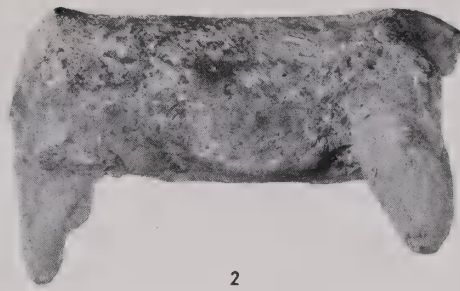

2

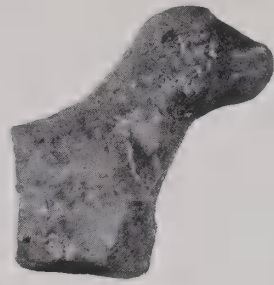

3

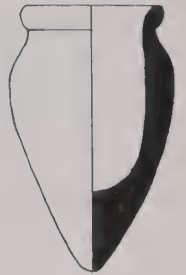

4

TOMB 76 A

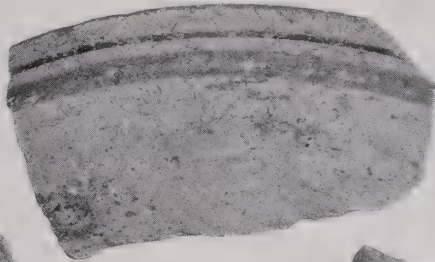

5

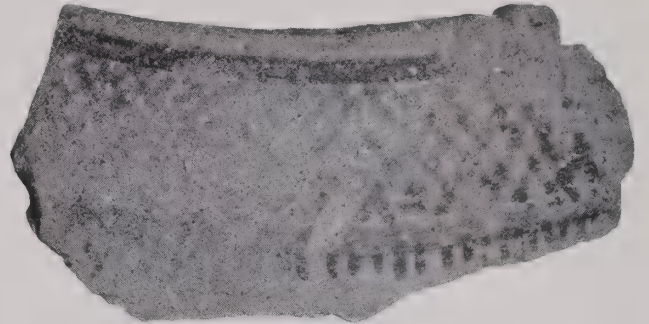

6



8

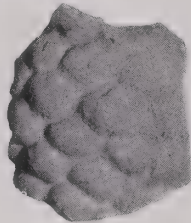

9



10

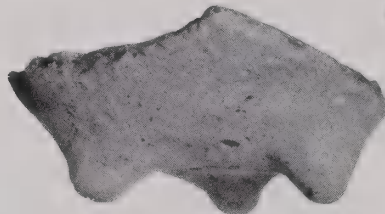

11

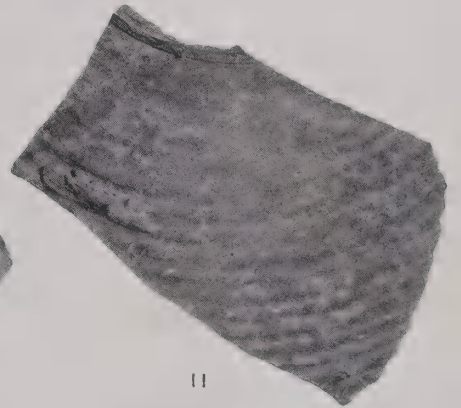

12



13



14

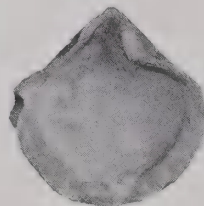

15



16

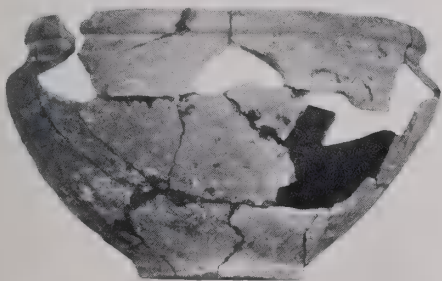

17



18



19



20

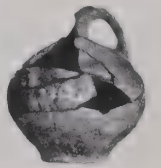

21

No.	Field No	Designation	Description	Scale	Date
TOMB 76 A					
1	4085	Bead	Intact, .005 long, glass, french blue 1, barrel disk	1:1	?
2	M 447	Bead?	T. .006, shell	1:1	?
3	M 446	Amulet	T. .007, fayence, near terre verte 3; Mut, Sekhmet, or some other Egyptian goddess (see p. 179)	1:1	?
4	M 477	Rubber	Intact(?), t. .062, basalt, perforated handle	1:5	?
5	M 516	Leg of bowl	Basalt	1:5	?
6	M 476	Spindle	Bone, one end socketed	1:1	?
7	3513	Jar	Rim d. .05, fayence, near cerulean blue 3, burnt umber 3 decoration; Egyptian(?)	1:1	?
TOMB 76 B					
8	M 445	Bracelet	"Bronze"	1:1	?
9	M 442	Ring	Intact, "bronze," coiled wire	1:1	?
10	4307	Ring	Intact, "bronze," coiled wire	1:1	?
11	M 475	Flint	T. .006, upper edge serrated and polished	1:1	?
12	M 444	Flint	T. .007, both edges serrated and polished, both ends blunted	1:1	?
13	M 443	Pendant	Fossil gastropod (see p. 179)	1:1	?
TOMB 80					
14	4108	Jug sherd	Many large mixed grits, well made, brown ocher 3, spaced vertical burnishing, blue-black 3 and light red 3 decoration	1:2	LB I
15	4107	Jar sherd	Many large mixed grits, blue-black 3 core, burnt umber 3 surface, indian red 1 and blue-black 3 decoration	1:2	LB
16	3538	Jar handle	Some large mixed grits, permanent brown 1 core, burnt umber 3 surface, pottery marks	1:2	LB
17	4109	Jar sherd	Fine ware, well made, heavily fired, blue-black 3 core, near burnt umber 3 surface, close horizontal burnishing, indian red 1 and blue-black 3 decoration	1:2	LB
18	4119	?	Intact(?), t. .065, basalt	1:5	?
19	M 527	Rubber-hammer	T. .048, limestone, highly polished through use	1:5	?
20	4120	Grinder	.117 wide, basalt	1:5	?
21	4121	Grinder	.104 wide, basalt	1:5	?
		Bowls(3)	Basalt, large		?

TOMB 76 A



TOMB 76 B

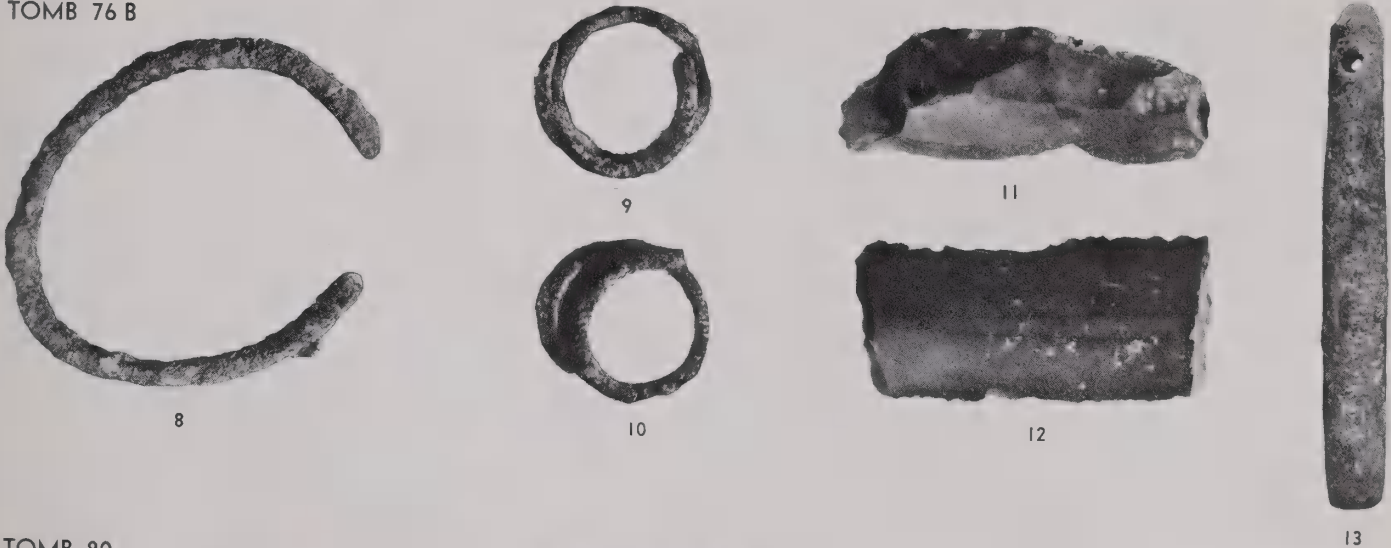

TOMB 80



OBJECTS FROM TOMBS 76 AND 80 (SEE PP. 127 AND 129)

No.	Field No.	Designation	Description	Date
TOMB 80				
1	M 529	Flint	T. .006, accidental serrations on both edges	?
2	M 528	Flint	T. .007, upper edge serrated and polished	?
3	M 517	Shell	T. .010	?
4	M 531	Bead	Intact, fayence, burnt umber 3, standard barrel	?
5	M 512	Dagger pommel	Marble, socketed and perforated for attachment	?
6	M 530	Flint	T. .005, worn double serrations and slight polish on both edges	?
7	M 518	Flint	T. .005, lower edge serrated and polished	?
8	4122	Macehead or loom weight	T. .034, basalt	?
TOMB 80 A				
9	4100	Bowl sherds	D. .30, brown ocher 3 core, light red 2 wash, close horizontal burnishing inside and over rim	MI
10	P 492	Bowl	See Pl. 75:5	LB II
11	4099	Stirrup cup	See Pl. 75:4	LB II
TOMB 80 B				
12	M 546	Statuette base	T. .017, fayence, feet of Egyptian pharaoh on heads of Negro and Semite, cobalt green 3 with Negro and hair of Semite in india ink 3	MI I (see p. 129)
TOMB 80 C				
13	P 494	Cover	See Pl. 75:14	E-MI*
14	P 316	Cover	See Pl. 75:15	E-MI*
15	P 314	Cooking bowl	See Pl. 75:10	E-MI
16	P 315	Cooking bowl	See Pl. 75:11	E-MI

\* See *OIP* XLII "Pottery Types," § 71.

TOMB 80

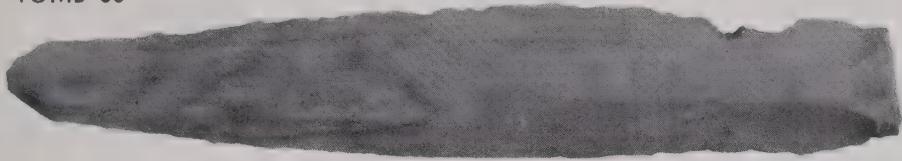

1

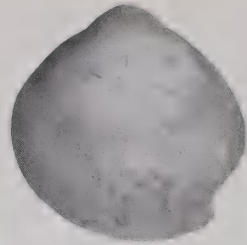

3



5

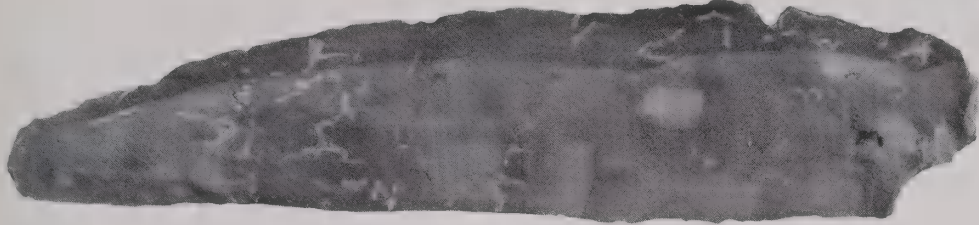

2

4

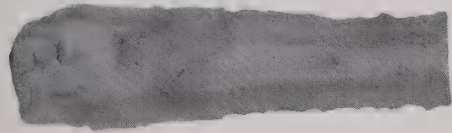

6



7

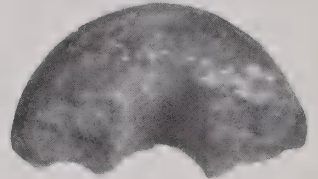

8

TOMB 80 A

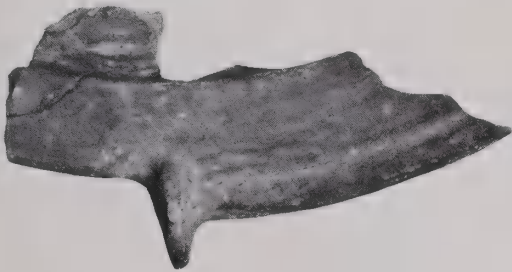

9

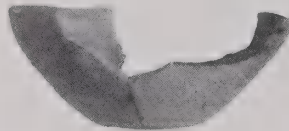

10

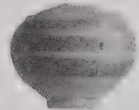

11

TOMB 80 B



12



TOMB 80 C

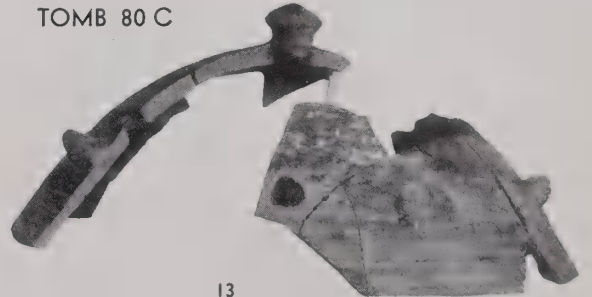

13

TOMB 80 C

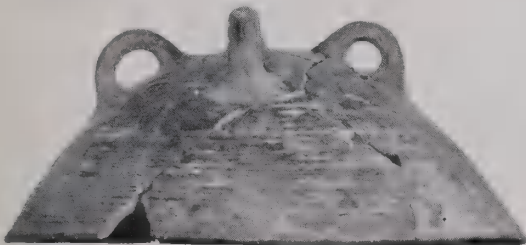

14

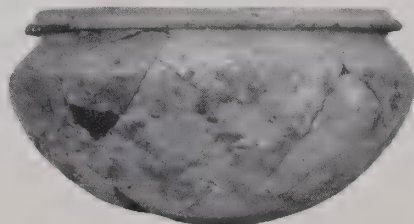

15

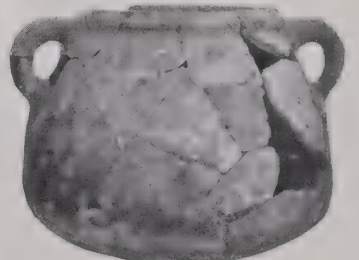

16

No.	Field No.	Designation	Description	Scale	Date
TOMB 80 C					
1	P 491	Bowl	See Pl. 75:8	1:5	E-MI
2	P 490	Chalice?	See Pl. 75:13	1:5	E-MI
3	4104	Flint	T. .004, double flaked serrations on upper edge, accidental serrations on lower edge	1:1	E-MI
4	M 701	Flint	T. .009, accidental serrations on upper edge	1:1	E-MI
TOMB 19					
5	428 <i>b</i>	Kohl-stick	Intact, ivory; found in No. 7	1:2	<i>Ca.</i> A.D. 400
6	427	Jar	Intact, glass, thinly blown, iridescent, fine glass thread spun spirally around body, thicker zigzag thread between shoulder and neck (see p. 189)	1:2	<i>Ca.</i> A.D. 400
7	428 <i>a</i>	Kohl tube	Intact, glass, iridescent, double, no connection between parts, decoration similar to that of No. 6 (see p. 189); No. 5 found in it	1:2	<i>Ca.</i> A.D. 400
8	429	Flask	Glass, iridescent, fluted body (see p. 189)	1:2	<i>Ca.</i> A.D. 400
9	431	Flagon	Intact; same as No. 10	1:2	<i>Ca.</i> A.D. 400
10	430	Flagon	Glass, iridescent, fluted sides, heavy glass threading below rim and around neck (see p. 189)	1:2	<i>Ca.</i> A.D. 400
11	x 434	Bottle	Intact, glass, cobalt blue 1, network decoration around cylindrical body (see p. 189); perhaps a pendant (cf. Beck in <i>Archaeologia</i> LXXVII, Fig. 27 B 15)	1:1	<i>Ca.</i> A.D. 400
12	x 435	Ring	Intact, gold band, green glass in gold setting (Fig. 176:18)	1:1	<i>Ca.</i> A.D. 400
13	432	Bottle	Intact; same as No. 11	1:1	<i>Ca.</i> A.D. 400
	433	Bowl	Basalt, 3 legs (see Fig. 160 and p. 186)		<i>Ca.</i> A.D. 400
TOMB 232					
14	4365	Flint	T. .009, worn serrations and polish on both edges	1:1	?
15	M 707	Needle	Intact, "bronze," bent to form eye	1:1	?
		Sherds	Intrusive		
TOMB 950					
16	M 3193	Bead	Intact, .003 long, fayence, cerulean blue 3 glaze, convex bicone disk	1:1	?

TOMB 80 C

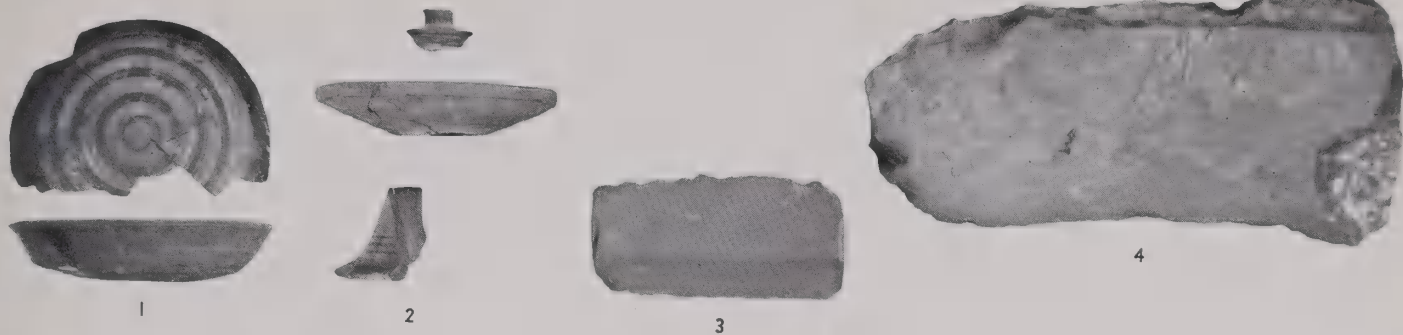

TOMB 19



TOMB 232

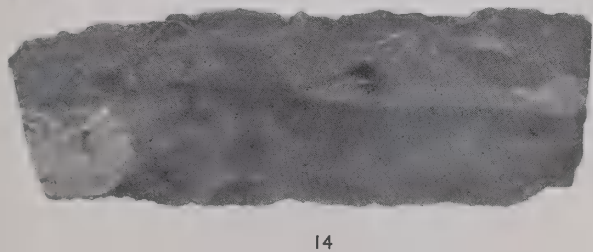

TOMB 950

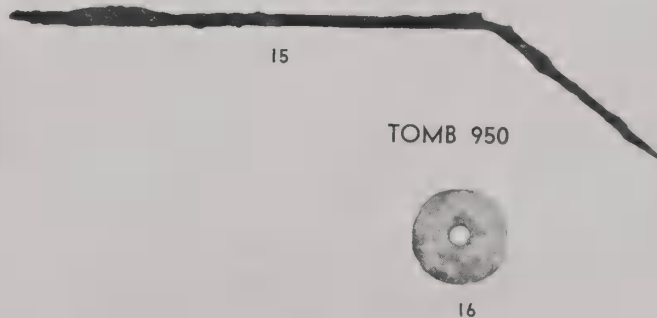

No.	Provenience	Field No.	Designation	Description	Date
1	Square J 18	2020	Scarab	Steatite, purely decorative design	Hyksos
2	Square J 18	2988	Scarab	Steatite, inscribed with king holding <i>h<sup>h</sup></i> -scepter and supervising "erection of the obelisk of Amon" ( <i>ts thn Imn</i> )	19th dynasty?
3	Square T 19	1683*	Cylinder seal	Fayence, blue. A bearded male figure in a long mantle and wearing a round cap with pointed top stands above the back of a lion. He has both hands raised and faces a nude goddess, who wears a pointed headdress. She appears in front view, except that her head is in profile, and both hands rest below her breasts. Above the raised hands of the man is what seems to be a rosette. To the right of the goddess rests a crouching bull, above which stands a conventionalized sacred tree flanked on each side by a long-horned animal standing on its hind legs. Between the animals and the tree are a fish and a human head with a round cap. Above the head of one of the animals is a disk. The other animal stands above a crouching stag, and behind him is an unrecognizable design. A bearded human-headed winged sphinx apparently wearing a round cap sits above the fore part of the lion. Above the sphinx is an animal head. At top and bottom single lines form borders.	LB (see pp. 182 f.)
4	Square Q 15	1179	Scarab	Steatite, traces of glaze, inscribed with <i>hpr</i> ("existence") between <i>nfr</i> ("goodness") signs	Hyksos?
5	Square Q 16	1161	Scarab	Intact, steatite, inscribed with bird-headed sphinx and 2 uraei, one before sphinx and one over back (cf. Petrie, <i>Gaza</i> IV, Pl. XI 404)	Hyksos
6	Square Q 16	2032	Scarab	Intact, steatite, traces of glaze, electrum setting, silver ring, back carved to represent an ape, base inscribed with name of Amon-Re	EI I? (see p. 186)
7	Square R 15	937	Scarab	Intact, composition, light blue, inscribed with tied lotus stems between "life" signs	?
8	West of T. 2	166	Tweezers	Intact, "bronze," tweezer ends .005 wide, edges of "arrow" blunt	?
9	Near T. 59	1856	Armor scales	"Bronze," t. .0005, each with 4 pairs of holes for insertion of "bronze" wire clinches. Group at right shows back view. (Cf. Bliss and Macalister, <i>Excavations in Palestine</i> , Fig. 62; Petrie, <i>Tools and Weapons</i> , Pl. XLII [lower left]; and <i>OIP</i> XLII, Pl. S5.)	?
10	Near T. 59	P 9	Potsherd	Base d. .08, charcoal gray 3 core, Naples yellow 3 surface, close burnishing, brown ocher 3 decoration	LB I?
11	Near T. 59	1853	Mold (at left) and modern impression	.003 deep, pottery, brown ocher 2; female head (cf. <i>OIP</i> XXVI, Pl. XXIII M 4117)	MI?

\* Described by Dr. H. H. von der Osten.

SQUARE J18

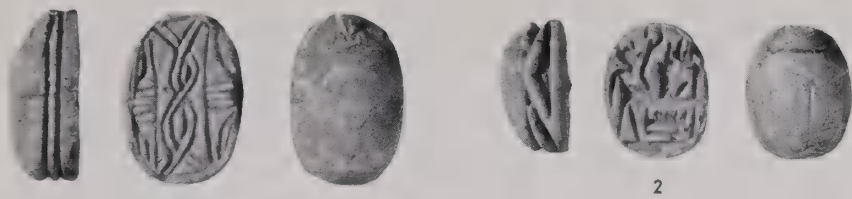

SQUARE Q15



SQUARE T19



SQUARE Q16

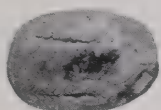
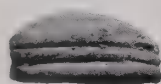

5

WEST OF TOMB 2

SQUARE Q16



SQUARE R15

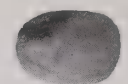
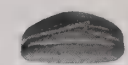

7

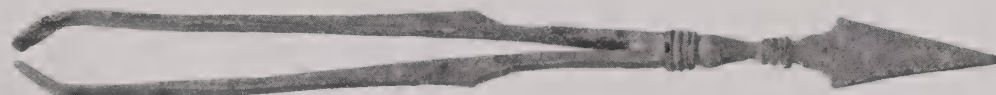

8

NEAR TOMB 59

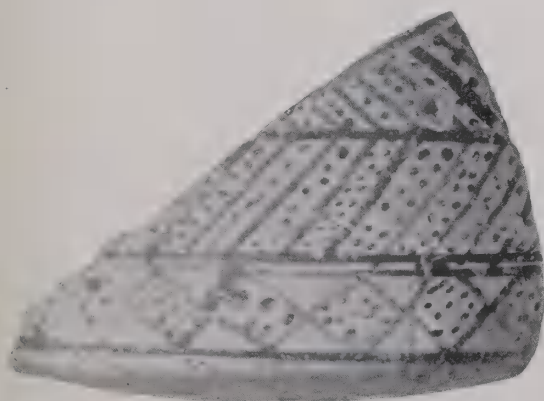
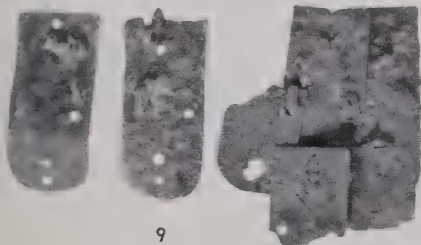

10



11



OBJECTS FROM THE EAST SLOPE WHICH COULD NOT BE ASSIGNED TO TOMBS. ACTUAL SIZE

This is a selected group of materials which are not duplicated elsewhere in the volume. Though some were found sufficiently near tombs to be suspected of having come from them, none has a context. In some cases periods have been assigned or proposed on the basis of inherent traits.

